

No Silver Bullet

CSCI 5828: Foundations of Software Engineering
Lecture 02 — 08/28/2014

Lecture Goals

- Introduce thesis of Fred Brook's No Silver Bullet
 - Classic essay by Fred Brooks discussing "Why is SE so hard?"
- Continue our discussion of core software engineering concepts

No Silver Bullet

- “**There is no single development**, in either technology or management technique, which **by itself** promises even **one order-of-magnitude improvement *within a decade*** in productivity, in reliability, in simplicity.”
 - — Fred Brooks, 1986
- i.e. There is no magical cure for the “software crisis”

Why? Essence and Accidents

- Brooks divides the problems facing software engineering into two categories
 - **essence**: difficulties inherent, or intrinsic, in the nature of software
 - **accidents**: difficulties related to the production of software
- Brooks argues that **most techniques attack the accidents** of software engineering

An Order of Magnitude

- In order to improve software development by a factor of 10
 - first, the accidents of software engineering **would have to account for 90% of the overall effort**
 - second, tools **would have to reduce accidental problems to zero**
- Brooks doesn't believe that the former is true...
 - and the latter is nigh impossible because each new tool or technique **solves some problems while introducing others**

The Essence

- Brooks divides the essence into four subcategories
 - complexity
 - conformity
 - changeability
 - invisibility

- Lets consider each in turn

Complexity (I)

- Software entities are amazingly complex
 - No two parts (above statements) are alike
 - Contrast with materials in other domains
- Large software systems have a huge number of states
 - Brooks claims they have an order of magnitude more states than computers (i.e. hardware) do
- As the size of a system increases, both the number **and types** of parts increase exponentially
 - the latter increase is the most significant

Complexity (II)

- You can't abstract away the complexity of the application domain. Consider:
 - air traffic control, international banking, avionics software
- These domains are intrinsically complex and this complexity will appear in the software system as designers attempt to model the domain
 - Complexity also comes from the numerous and tight relationships between heterogeneous software artifacts such as specs, docs, code, test cases, etc.

Complexity (III)

- Problems resulting from complexity
 - difficult team communication
 - product flaws; cost overruns; schedule delays
 - personnel turnover (loss of knowledge)
 - unenumerated states (lots of them)
 - lack of extensibility (complexity of structure)
 - unanticipated states (security loopholes)
 - project overview is difficult

Conformity (I)

- A lot of complexity facing software engineers is **arbitrary**
 - Consider designing a software system to support an existing business process when a new VP arrives at the company
 - The VP decides to “make a mark” on the company and changes the business process
 - Our system must now conform to the (from our perspective) **arbitrary changes** imposed by the VP

Conformity (II)

- Other instances of conformity
 - Adapting to a pre-existing environment
 - such as integrating with legacy systems
 - and if the environment changes (for whatever reason), you can bet that software will be asked to change in response
 - Implementing regulations or rules that may change from year to year
 - Dealing with a change in vendor imposed by your customer
- Main Point: **It is almost impossible to plan for arbitrary change;**
 - instead, you just have to wait for it to occur and deal with it when it happens

Changeability (I)

- Software is constantly asked to change
 - Other things are too, however, manufactured things are rarely changed after they have been created
 - instead, changes appear in later models
 - automobiles are recalled only infrequently
 - buildings are expensive to remodel

Changeability (II)

- With software, **the pressure to change is greater**
 - in a project, it is functionality that is often asked to change and **software EQUALS functionality** (plus its malleable)
 - clients of a software project often don't understand enough about software to understand when a change request requires significant rework of an existing system
 - Contrast with more tangible domains
 - Imagine asking for a new layout of a house after the foundation has been poured

Invisibility (I)

- Software is, by its nature, invisible and intangible; it is difficult to design graphical displays of software that convey meaning to developers
 - Contrast to blueprints: here geometry can be used to identify problems and help optimize the use of space
- But with software, its difficult to reduce it to diagrams
 - UML contains 13 different diagram types (!)
 - to model class structure, object relationships, activities, event handling, software architecture, deployment, packages, etc.
 - The notations of the different types almost never appear in the same diagram
 - they really do document 13 different aspects of the software system!

Invisibility (II)

- Hard to get both a “big picture” view as well as details
 - Hard to convey just one issue on a single diagram
 - instead multiple concerns crowd and/or clutter the diagram hindering understanding
- This lack of visualization deprives the engineer from using the brain's powerful visual skills

What about “X”?

- Brooks argues that past breakthroughs solve accidental difficulties
 - High-level languages
 - Time-Sharing
 - Programming Environments
 - OO Analysis, Design, Programming
 - ...

Promising Attacks on the Essence

- Buy vs. Build
 - Don't develop software when you can avoid it
- Rapid Prototyping
 - Use to clarify requirements
- Incremental Development
 - don't build software, grow it
- Great designers
 - Be on the look out for them, when you find them, don't let go!

No Silver Bullet, Take 2

- Brooks reflects on No Silver Bullet[‡], ten years later
 - Lots of people have argued that their methodology, technique, or tool is the silver bullet for software engineering
 - If so, they didn't meet the **deadline of 10 years** or the target of a **10 times improvement** in the production of software
- Others misunderstood what Brooks calls “obscure writing”
 - e.g., “accidental” did not mean “occurring by chance”;
 - instead, he meant that the use of technique A for benefit B unfortunately introduced problem C into the process of software development

[‡] This reflection appears in The Mythical Man-Month, 20th Anniversary Edition

The Size of Accidental Effort

- Some people misunderstood his point with the 90% figure
 - Brooks doesn't actually think that accidental effort is 90% of the job
 - its much smaller than that
- As a result, reducing it to zero (which is effectively impossible) will not give you an order of magnitude improvement

Obtaining the Increase

- Some people interpreted Brooks as saying that the essence could never be attacked
 - That's not his point; he said that **no single technique could produce an order of magnitude increase by itself**
 - He argues instead that **several techniques in tandem could achieve it but that requires industry-wide enforcement and discipline**
- Brooks states:
 - “We will surely make substantial progress over the next 40 years; an order of magnitude improvement over 40 years is hardly magical...”

Quiz Yourself

- Essence or Accident?
 - A bug in a financial system is discovered that came from a conflict in state/federal regulations on one type of transaction
 - A program developed in two weeks using a whiz bang new application framework is unable to handle multiple threads since the framework is not thread safe
 - A new version of a compiler generates code that crashes on 32-bit architectures; the previous version did not
 - A fickle customer submits 10 change requests per week after receiving the first usable version of a software system

Returning to SE Intro

- Lets continue our “Overview of Software Engineering” that was started in Lecture 1
 - This draws on material from Software Engineering: Theory and Practice by Pfleeger and Atlee
 - As such, some material is copyright © 2006 Pearson/Prentice Hall.

What is Software Engineering?

- Simply Put: It is **solving problems with software-based systems**
 - Design and development of these systems require
 - **Analysis**
 - decomposing large problems into smaller, understandable pieces
 - abstraction is the key
 - **Synthesis**
 - building large software systems from smaller building blocks
 - composition is challenging

Solving Problems (I)

- To aid us in solving problems, we apply techniques and tools
 - **techniques:** a formal “recipe” for accomplishing a goal that is typically independent of the tools used
 - automated builds, configuration management, software testing, etc.
 - **tools:** an instrument or automated system for accomplishing something in a better way, where “better” can mean more efficient, more accurate, faster, etc.
 - maven, git, jenkins, etc.

Solving Problems (II)

- To aid us in solving problems, we apply
 - **procedures: a combination of tools and techniques** that, in concert, **produce a particular product**
 - **paradigms: a particular philosophy or approach for building a product**
 - Think: “cooking style”: may share procedures, tools, and techniques with other styles but apply them in different ways
 - By analogy: **OO approach** to development vs. **the structured approach**
 - Both approaches use similar things:
 - reqs., design, code, editors, compilers, etc.
 - But think about the problem in fundamentally different ways

Software Engineering: The Good

- Software engineering has helped to produce systems that improve our lives in numerous ways
 - helping us to perform tasks more quickly and effectively
 - supporting advances in medicine, agriculture, communication, transportation, and other industries
- Indeed, software-based systems are now ubiquitous

Software Engineering: The Bad (I)

- Software is not without its problems
 - Systems function, but not in the way we expect
 - Or systems crash, generate the wrong output, etc.
 - Or the process for producing a system is riddled with problems leading to a failure to produce the entire system
 - many projects get cancelled without ever producing a system
- One study in the late 80s found that in a survey of 600 firms, more than 35% reported having a **runaway development project**. A runaway project is one in which the budget and schedule are completely out of control.

Software Engineering: The Bad (II)

- CHAOS Report from Standish Group
 - Has studied over 40,000 industry software development projects over the course of 1994 to 2004.
 - Success rates (projects completed on-time, within budget) in 2004 was 34%, up from 16.2% in 1994
 - Failure rates (projects cancelled before completion) in 2004 was 15%, down from 31% in 1994.
 - In 2004, “challenged” projects made up 51% of the projects included in the survey.
 - A challenged project is one that was over time, over budget and/or missing critical functionality

Software Engineering: The Bad (III)

- Most challenged projects in 2004 had a cost overrun of under 20% of the budget, compared to 60% in 1994
- The average cost overrun in 2004 was 43% versus an average cost overrun of 180% in 1994.
- In 2004, total U.S. project waste was 55 billion dollars with 17 billion of that in cost overruns; Total project spending in 2004 was 255 billion
 - In 1994, total U.S. project waste was 140 billion (80 billion from failed projects) out of a total of 250 billion in project spending

Software Engineering: The Bad (IV)

- So, things are getting better (attributed to better project management skills industry wide), but we still have a long way to go.
 - 66% of the surveyed projects in 2004 did not succeed!

Software Engineering: The Ugly (I)

- Loss of NASA's Mars Climate Observer
 - due to mismatch of English and Metric units!
 - even worse: problem was known but politics between JPL and Houston prevented fix from being deployed
- Denver International Airport
 - Luggage system: 16 months late, 3.2 billion dollars over budget!
- IRS hired Sperry Corporation to build an automated federal income tax form processing process
 - An extra \$90 M was needed to enhance the original \$103 M product
 - IRS lost \$40.2 M on interest and \$22.3 M in overtime wages because refunds were not returned on time

Software Engineering: The Ugly (II)

- Therac-25 (safety critical system: failure poses threat to life or health)
 - Machine had two modes:
 - “electron beam” and “megavolt x-ray”
 - “megavolt” mode delivered x-rays to a patient by colliding high energy electrons into a “target”
 - Patients died when a “race condition” in the software allowed the megavolt mode to engage when the target was not in position
 - Related to a race between a “type ahead” feature in the user interface and the process for rotating the target into position

Testing

- Testing is a **critical element** of software development life cycles
 - called **software quality control** or **software quality assurance**
 - basic goals: **validation** and **verification**
 - validation: **are we building the right product?**
 - verification: **does “X” meet its specification?**
 - where “X” can be code, a model, a design diagram, a requirement, ...
 - At each stage, we need to verify that the thing we produce accurately represents its specification

Terminology

- An **error** is a mistake made by an engineer
 - often a misunderstanding of a requirement or design specification
- A **fault** is a manifestation of that error in the code
 - what we often call “a bug”
- A **failure** is an incorrect output/behavior that is caused by executing a fault
 - The failure may occur immediately (crash!) or much, much later in the execution
- **Testing** attempts to **surface failures** in our software systems
 - **Debugging** attempts to **associate failures with faults** so they can be removed from the system
- If a system passes all of its tests, is it free of all faults?

No!

- Faults may be hiding in portions of the code that only rarely get executed
 - “Testing can only be used to prove the existence of faults not their absence” or “Not all faults have failures”
 - Sometimes faults mask each other resulting in no visible failures!
 - this is particularly insidious
- However, if we do a good job in creating a test set that
 - covers all functional capabilities of a system
 - and covers all code using a metric such as “branch coverage”
- Then, having all tests pass increases our confidence that our system has high quality and can be deployed

Looking for Faults

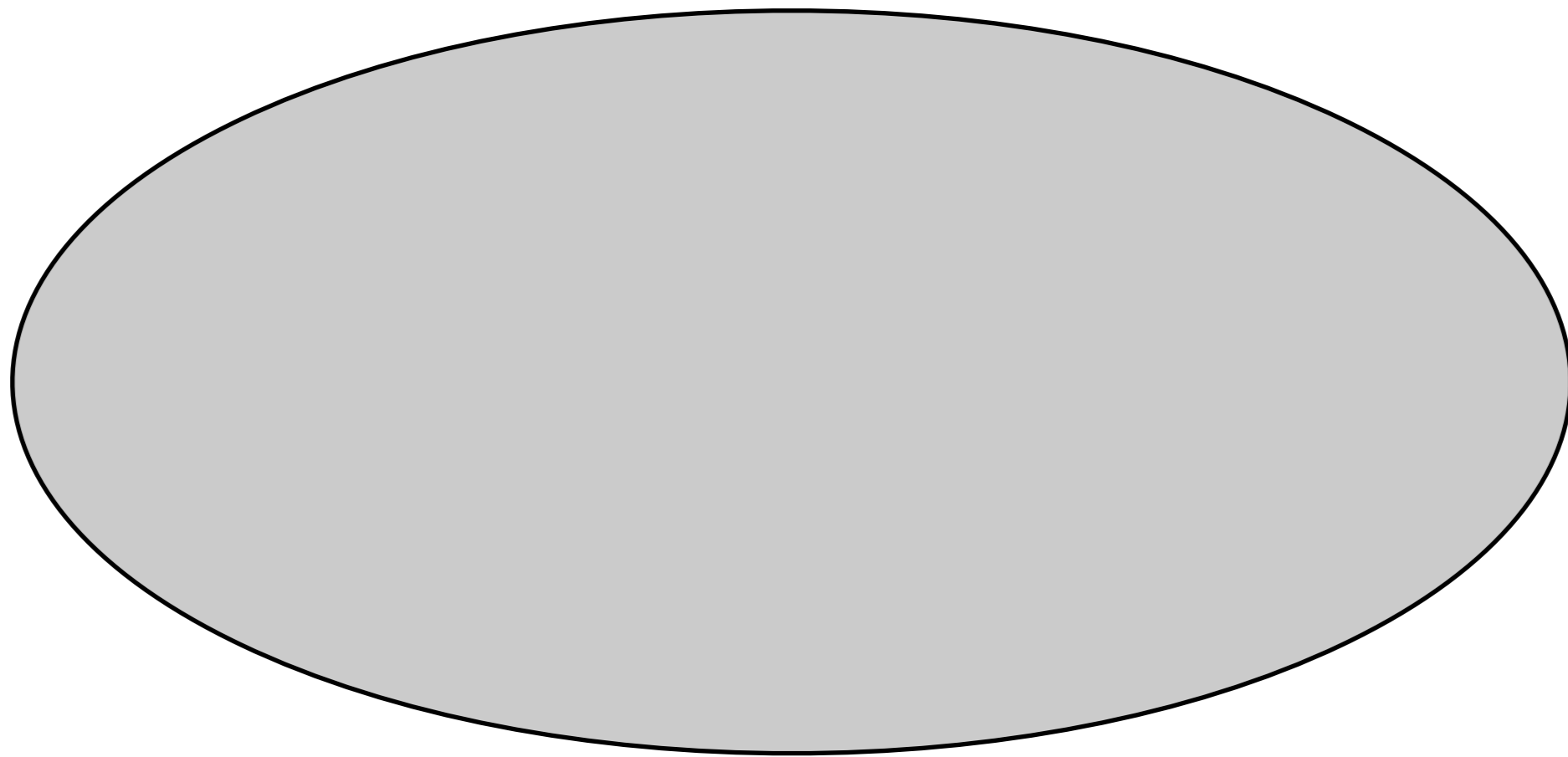

All possible states/behaviors of a system

Looking for Faults

As you can see, its not very comprehensive

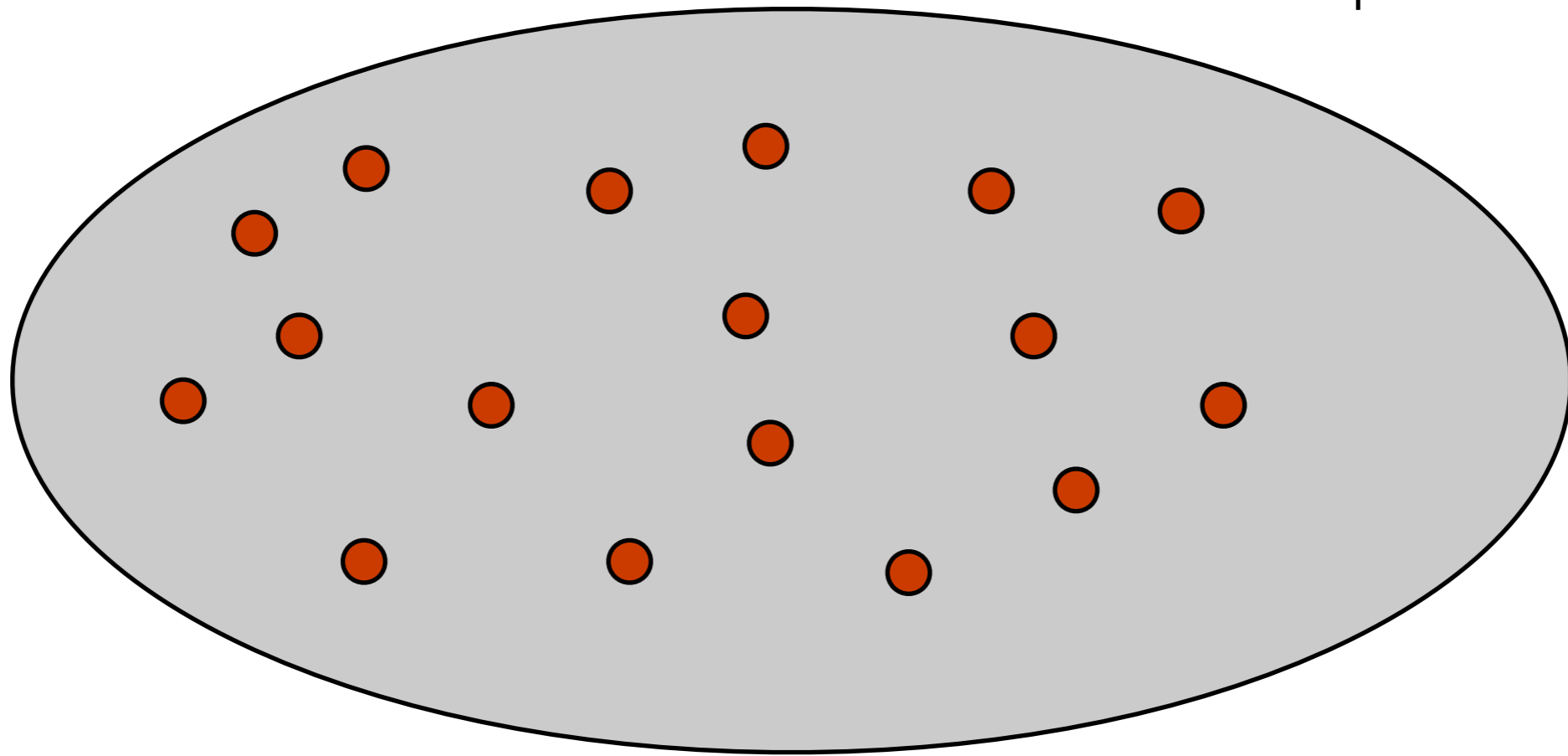

Tests are a way of sampling the behaviors of a software system, looking for failures

One way forward? Fold

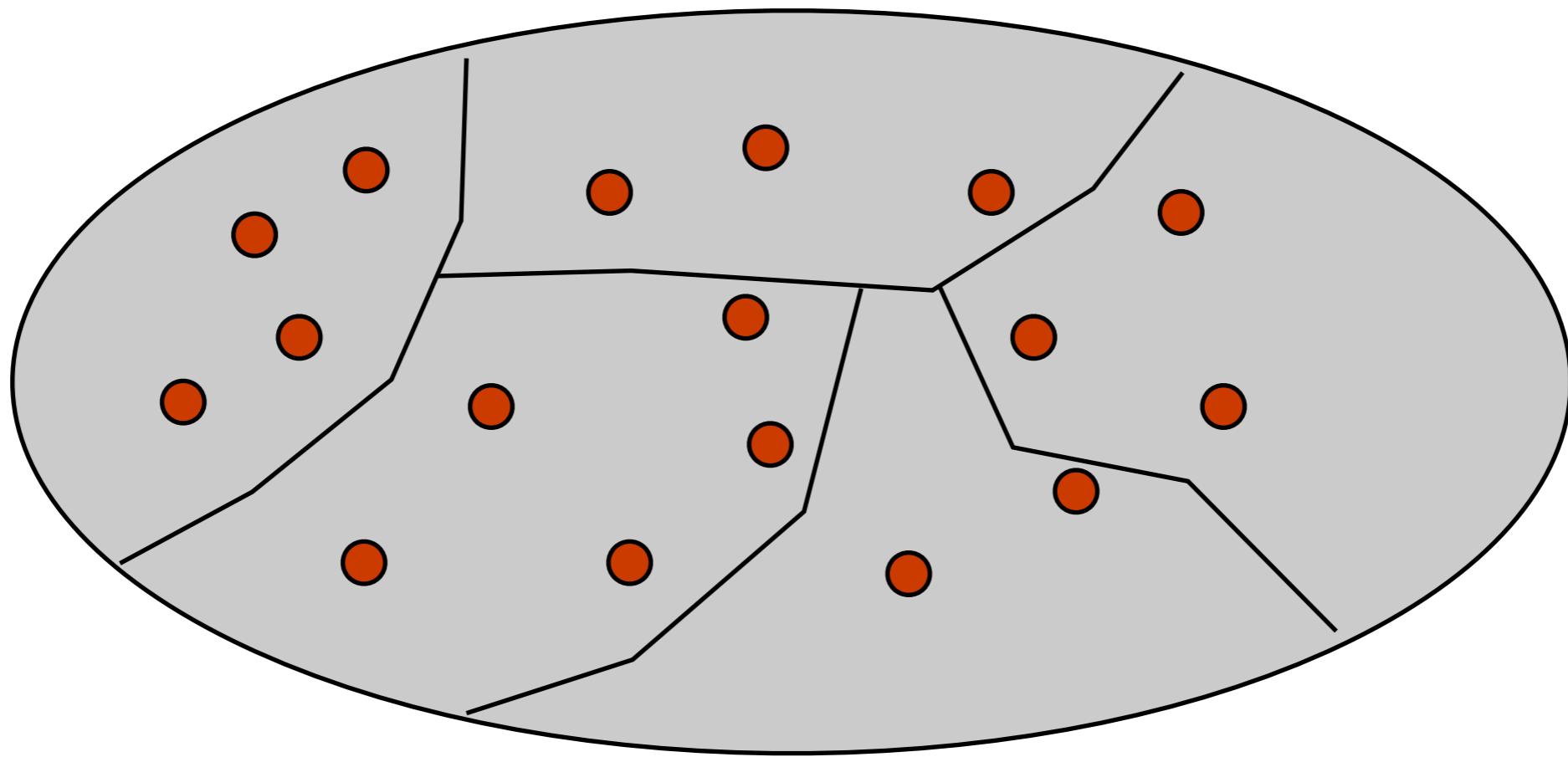

The testing literature advocates folding the space into equivalent behaviors and then sampling each partition

What does that mean?

- Consider a simple example like the greatest common denominator function
 - `int gcd(int x, int y)`
 - At first glance, this function has an infinite number of test cases
 - But lets fold the space
 - `x=6 y=9`, returns 3, tests common case
 - `x=2 y=4`, returns 2, tests when x is the GCD
 - `x=3 y=5`, returns 1, tests two primes
 - `x=9 y=0`, returns ?, tests zero
 - `x=-3 y=9`, returns ?, tests negative

Completeness

- From this discussion, it should be clear that **“completely” testing a system is impossible**
 - **So, we settle for heuristics**
 - attempt to fold the input space into different functional categories
 - then create tests that sample the behavior/output for each functional partition
- As we will see, we also look at our **coverage of the underlying code**; are we hitting all statements, all branches, all loops?

Continuous Testing

- Testing is a continuous process that should be performed at every stage of a software development process
 - During requirements gathering, for instance, we must continually query the user, “Did we get this right?”
 - Facilitated by an emphasis on iteration throughout a life cycle
 - at the end of each iteration
 - we check our results to see if what we built is meeting our requirements (specification)

Testing the System (I)

- **Unit Tests**

- Tests that cover low-level aspects of a system
 - For each module, does each operation perform as expected
 - For method **foo()**, we'd like to see another method **testFoo()**

- **Integration Tests**

- Tests that check that modules work together in combination
- Most projects on schedule until they hit this point (MMM, Brooks)
 - All sorts of hidden assumptions are surfaced when code written by different developers are used in tandem
- Lack of integration testing has led to spectacular failures (Mars Polar Lander)

Testing the System (II)

- **System Tests**

- Tests performed by the developer to ensure that all major functionality has been implemented
 - Have all user stories been implemented and function correctly?

- **Acceptance Tests**

- Tests performed by the user to check that the delivered system meets their needs
 - In large, custom projects, developers will be on-site to install system and then respond to problems as they arise

Multi-Level Testing

- Once we have code, we can perform three types of tests
 - **Black Box Testing**
 - Does the system behave as predicted by its specification
 - **Grey Box Testing**
 - Having a bit of insight into the architecture of the system, does it behave as predicted by its specification
 - **White Box Testing**
 - Since, we have access to most of the code, lets make sure we are covering all aspects of the code: statements, branches, ...

Black Box Testing

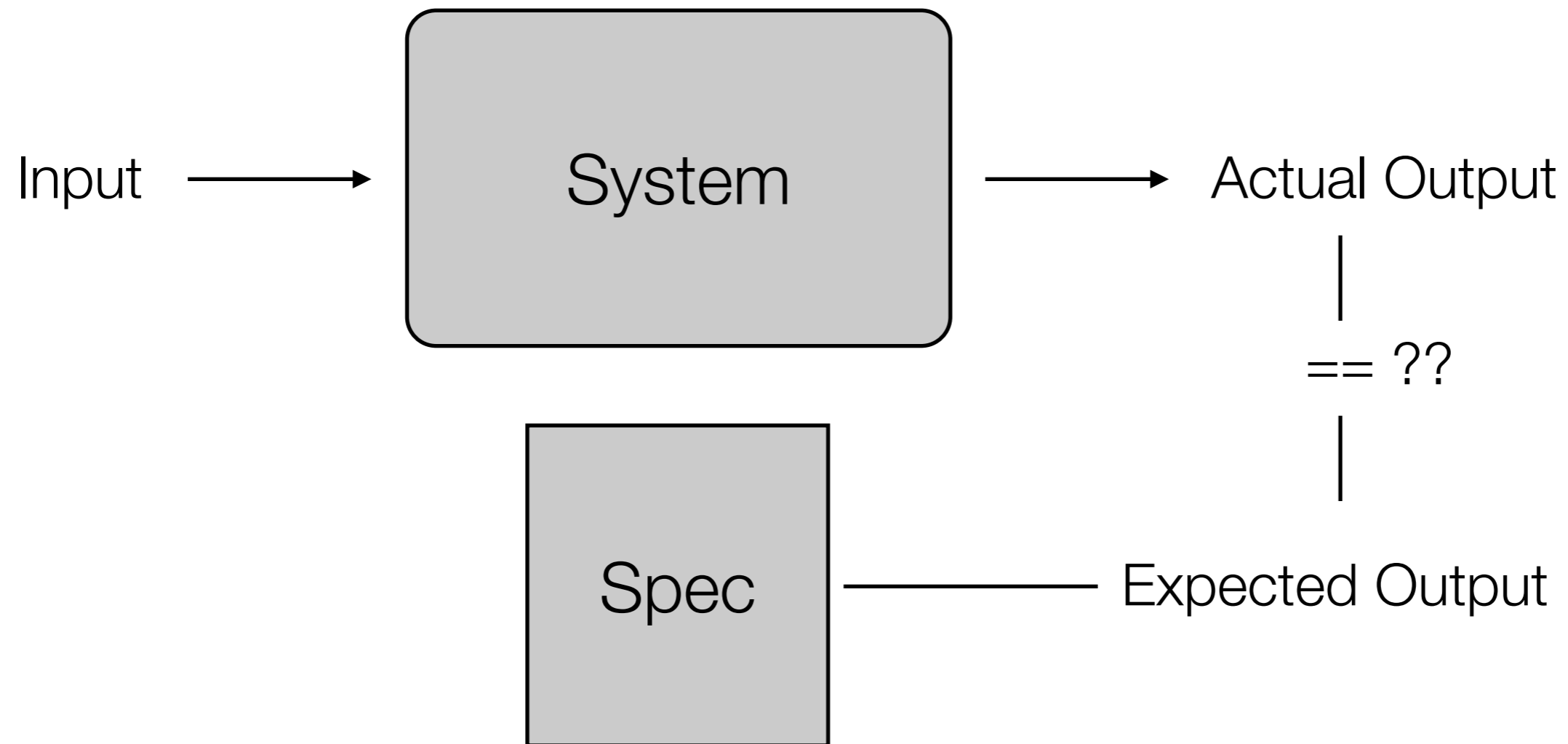

A **black box test** passes **input** to a system, records the **actual output** and compares it to the **expected output**

Note: if you do not have a spec, then any behavior by the system is correct!

Results

- if actual output == expected output
 - TEST PASSED
- else
 - TEST FAILED
- Process
 - Write at least one test case per functional capability
 - Iterate on code until all tests pass
- Need to automate this process as much as possible

Black Box Categories

- Functionality
 - User input validation (based off specification)
 - Output results
 - State transitions
 - are there clear states in the system in which the system is supposed to behave differently based on the state?
- Boundary cases and off-by-one errors

Grey Box Testing

- Use knowledge of system's architecture to create a more complete set of black box tests
 - Verifying auditing and logging information
 - for each function is the system really updating all internal state correctly
 - Data destined for other systems
 - System-added information (timestamps, checksums, etc.)
 - “Looking for Scraps”
 - Is the system correctly cleaning up after itself
 - temporary files, memory leaks, data duplication/deletion

White Box Testing

- Writing test cases with complete knowledge of code
 - Format is the same: input, expected output, actual output
- But, now we are looking at
 - code coverage (more on this in a minute)
 - proper error handling
 - working as documented (is method “foo” thread safe?)
 - proper handling of resources
 - how does the software behave when resources become constrained?

Code Coverage (I)

- A criteria for knowing white box testing is “complete”
 - statement coverage
 - write tests until all statements have been executed
 - branch coverage (a.k.a. edge coverage)
 - write tests until each edge in a program’s control flow graph has been executed at least once (covers true/false conditions)
 - condition coverage
 - like branch coverage but with more attention paid to the conditionals (if compound conditional, ensure that all combinations have been covered)

Code Coverage (II)

- A criteria for knowing white box testing is “complete”
 - path coverage
 - write tests until all paths in a program’s control flow graph have been executed multiple times as dictated by heuristics, e.g.,
 - for each loop, write a test case that executes the loop
 - zero times (skips the loop)
 - exactly one time
 - more than once (exact number depends on context)

A Sample Ada Program to Test

```
1      function P return INTEGER is
2      begin
3          X, Y: INTEGER;
4          READ(X); READ(Y);
5          while (X > 10) loop
6              X := X - 10;
7              exit when X = 10;
8          end loop;
9          if (Y < 20 and then X mod 2 = 0) then
10             Y := Y + 20;
11         else
12             Y := Y - 20;
13         end if;
14         return 2 * X + Y;
15     end P;
```

P's Control Flow Graph (CFG)

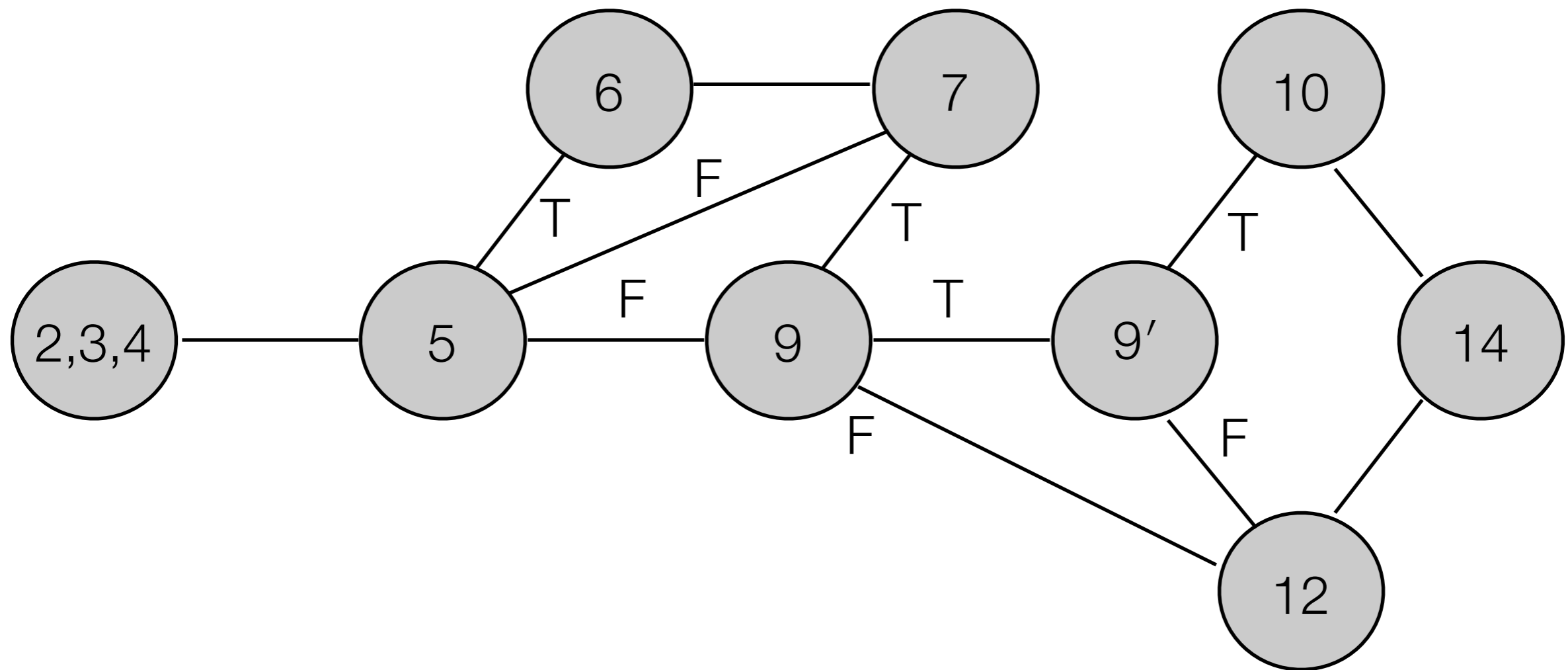

White-box Testing Criteria

- Statement Coverage
 - Create a test set T such that
 - by executing P for each t in T
 - each elementary statement of P is executed at least once

All-Statements Coverage of P

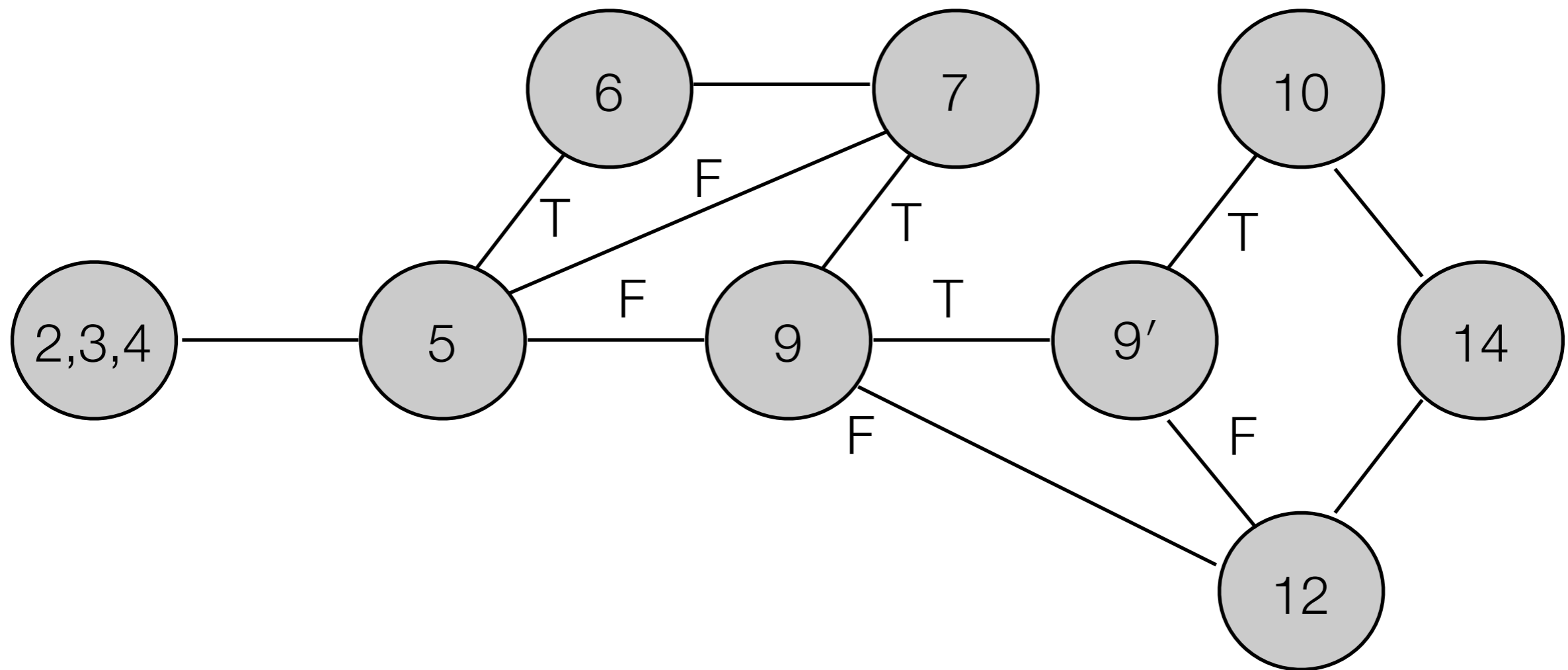

All-Statements Coverage of P

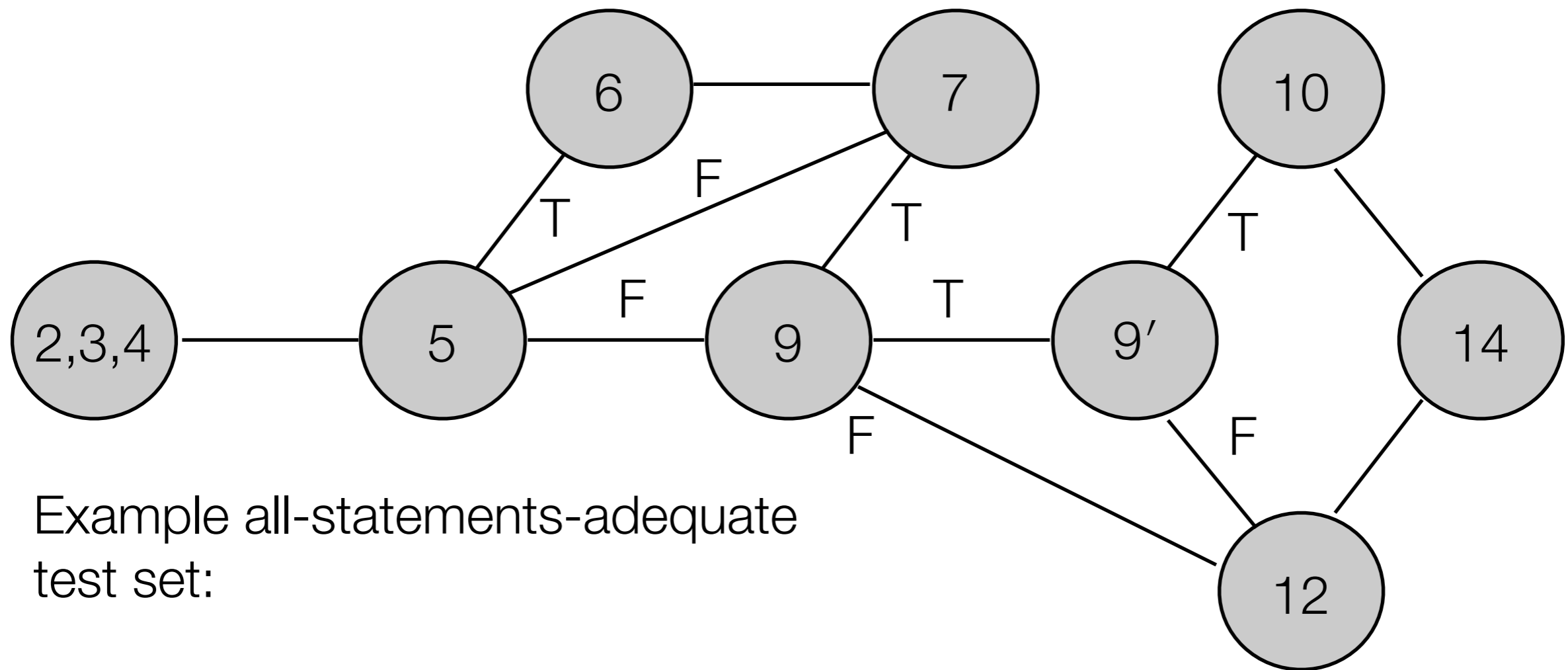

Example all-statements-adequate
test set:

All-Statements Coverage of P

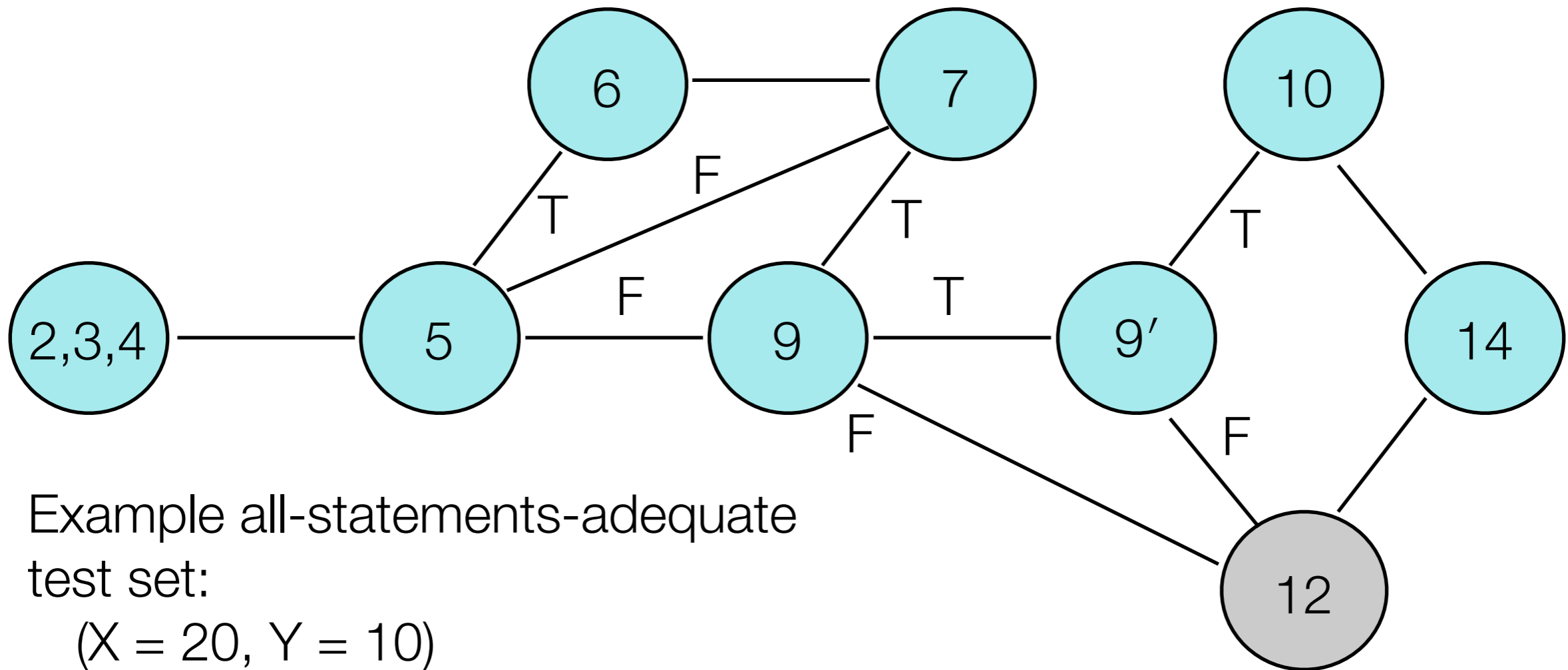

All-Statements Coverage of P

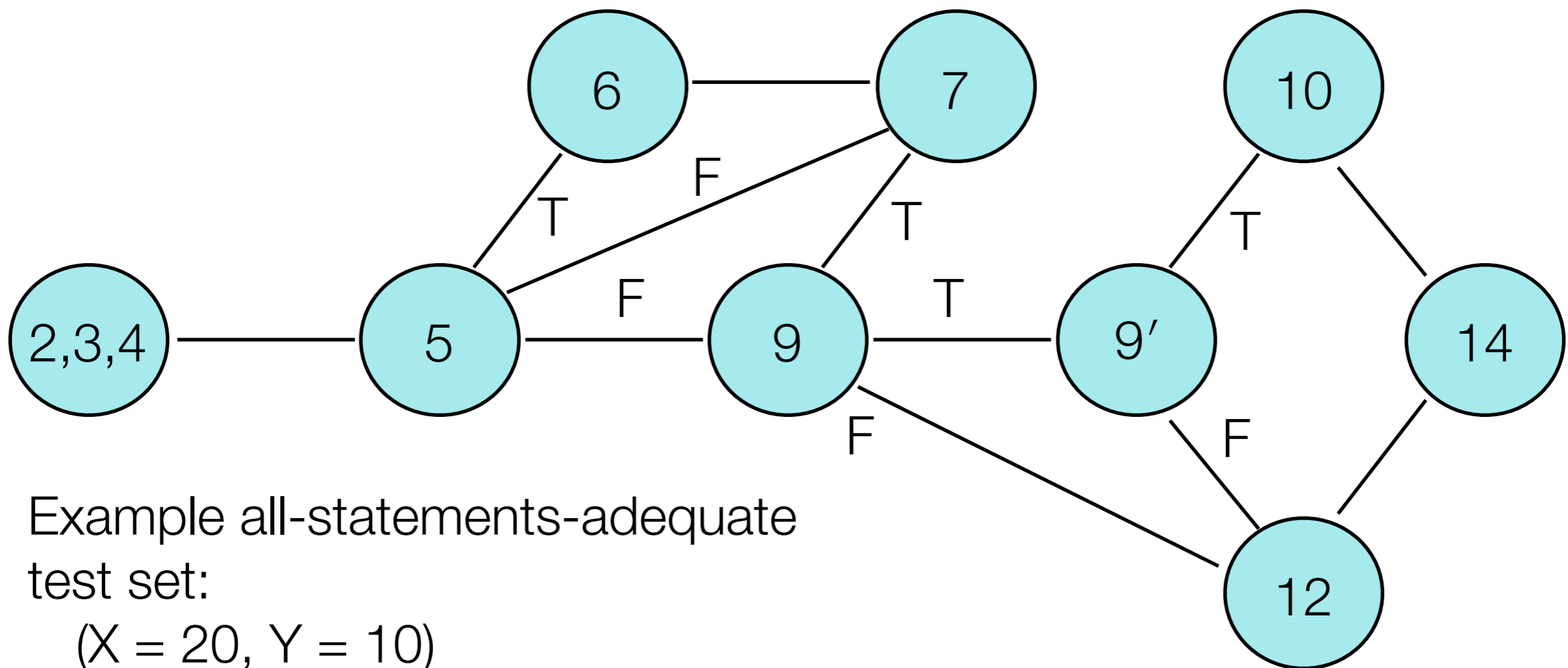

Example all-statements-adequate
test set:

($X = 20$, $Y = 10$)

($X = 20$, $Y = 30$)

White-box Testing Criteria

- Edge Coverage
 - Select a test set T such that
 - by executing P for each t in T
 - each edge of P 's control flow graph is traversed at least once

All-Edges Coverage of P

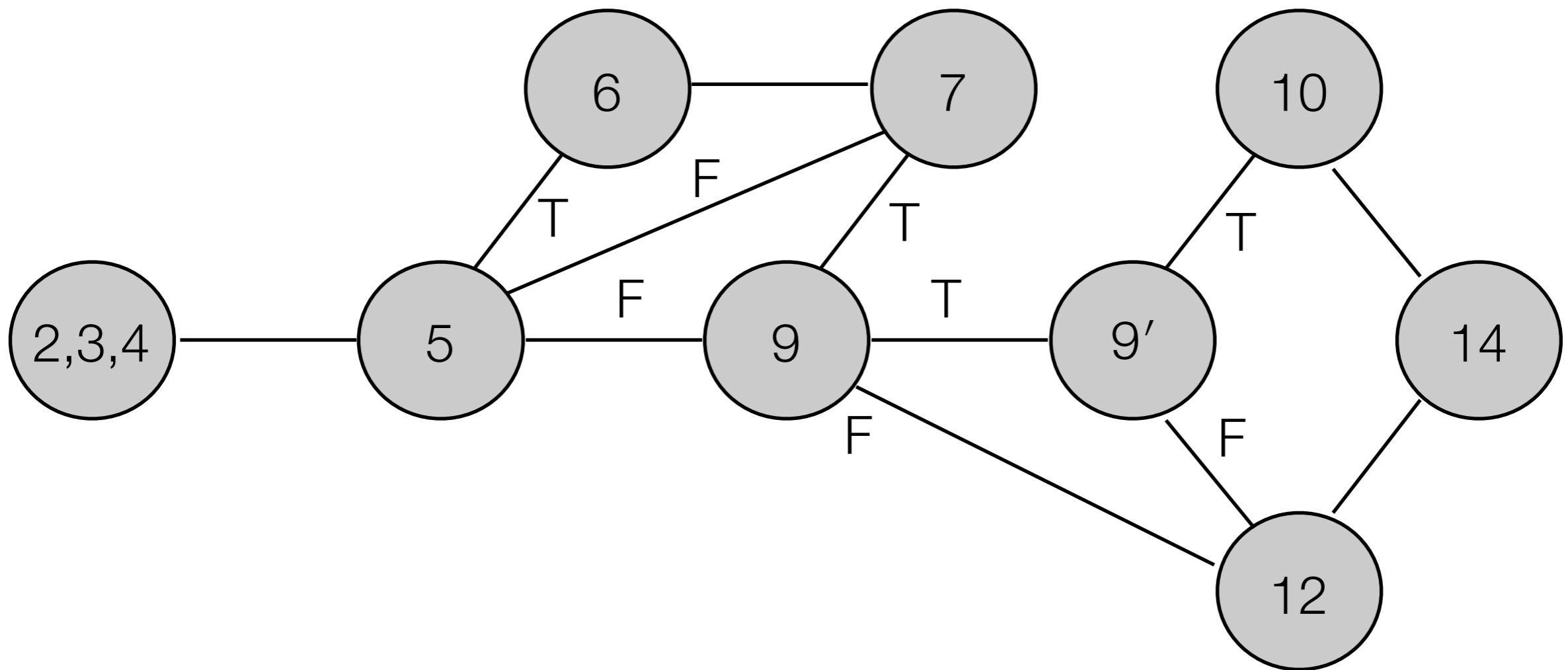

All-Edges Coverage of P

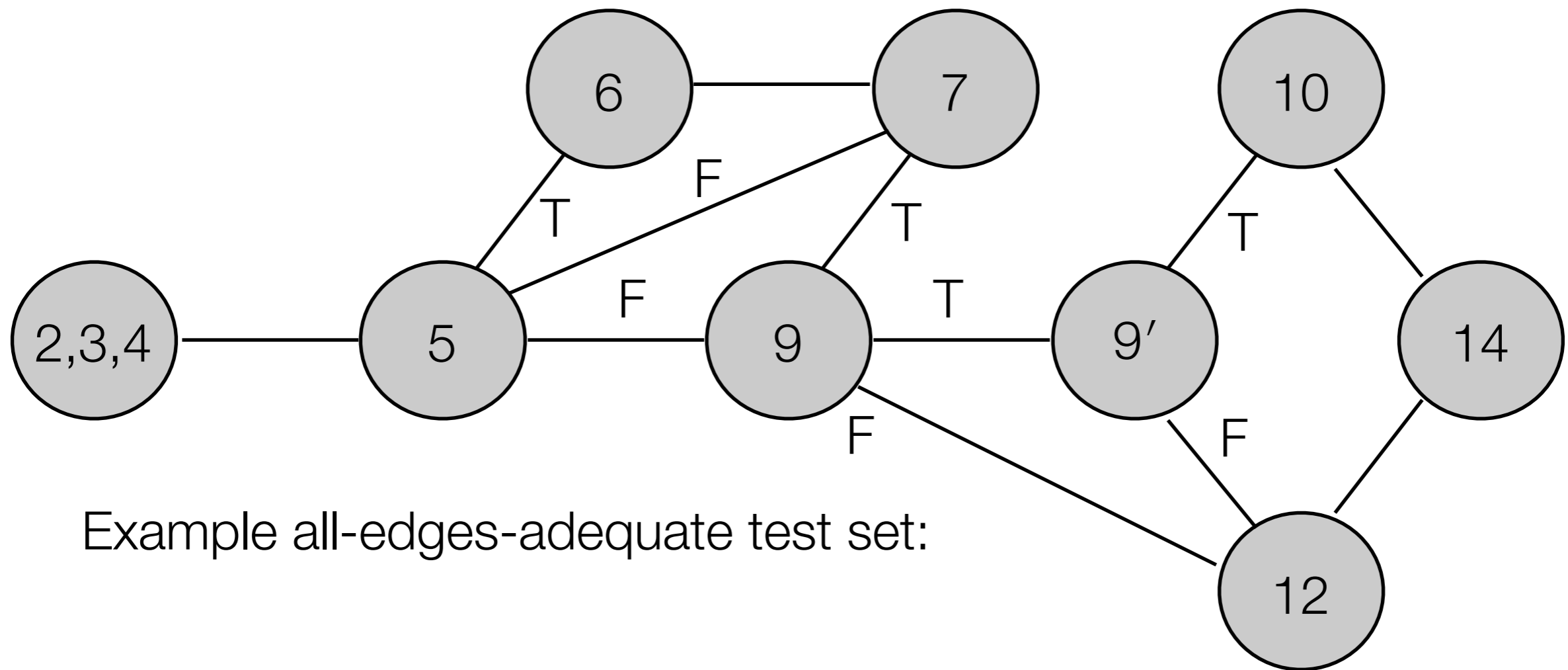

Example all-edges-adequate test set:

All-Edges Coverage of P

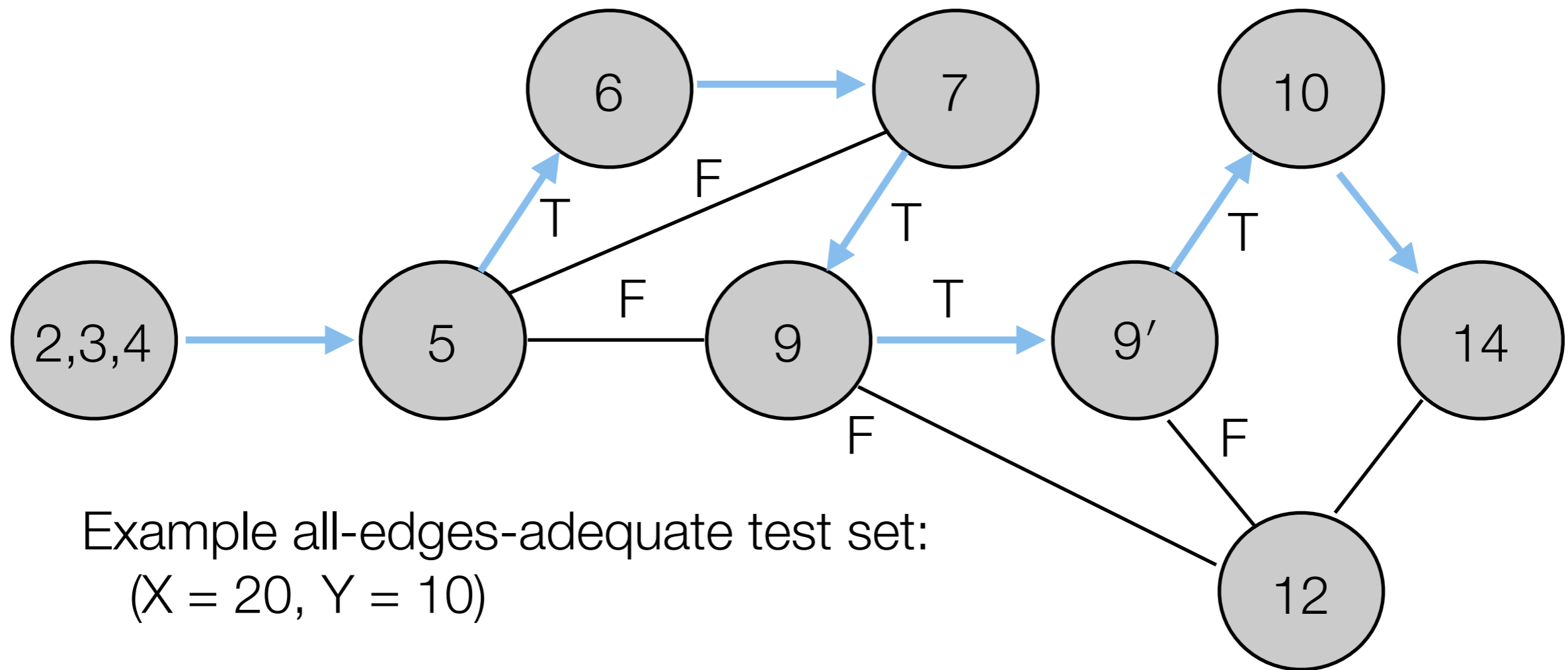

Example all-edges-adequate test set:
($X = 20$, $Y = 10$)

All-Edges Coverage of P

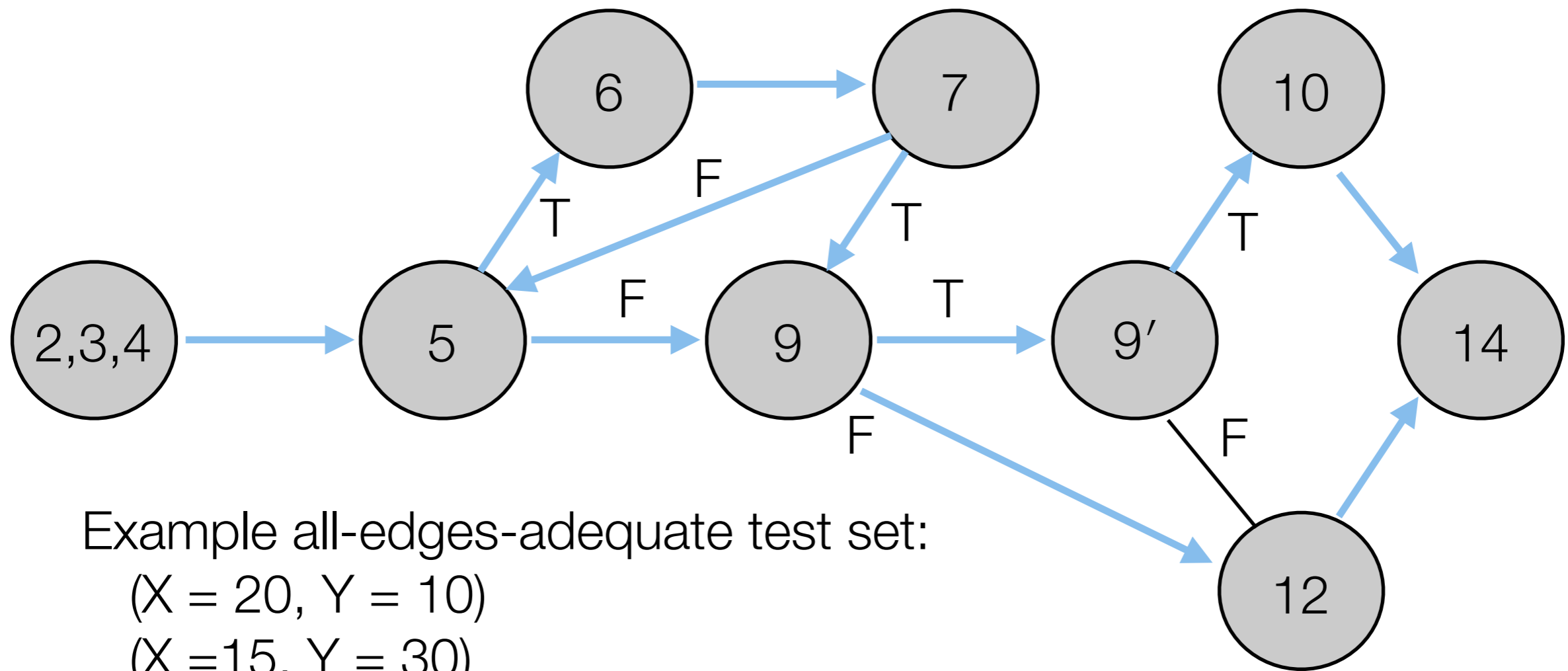

What is Good Software?

- “Good” is often associated with some definition of quality. The higher the quality, the better the software.
- The problem? Many different definitions of quality!
 - **Transcendental**: where quality is something we can recognize but not define (“I know it when I see it”)
 - **User**: where quality is determined by evaluating the fitness of a system for a particular purpose or task (or set of tasks)
 - **Manufacturing**: quality is conformance to a specification
 - **Product**: quality is determined by internal characteristics (e.g. number of bugs, complexity of modules, etc.)
 - **Value**: quality depends on the amount customers are willing to pay
 - customers adopt “user view”; developers adopt “manufacturing view”, researchers adopt “product view”; “value view” can help to tie these together

What is Good Software?

- Good software engineering must always include a **strategy for producing high quality software**
- Three common ways that SE considers quality:
 - The quality of the product (product view)
 - The quality of the process (manufacturing view)
 - The quality of the product in the context of a business environment (user view)
- The results of the first two are termed the “technical value of a system”; The latter is the “business value of a system”

The Quality of the Product

- Users judge a system on external characteristics
 - correct functionality, number of failures, types of failures
- Developers judge the system on internal characteristics
 - types of faults, reliability, efficiency, etc.
- Quality models can be used to relate these two views
 - An example is McCall's quality model
 - This model can be useful to developers: want to increase “reliability”
examine your system's “consistency, accuracy, and error tolerance”

The Quality of the Process (I)

- Quality of the development and maintenance process is as important as the product quality
 - The development process needs to be modeled

The Quality of the Process (II)

- Modeling will address questions such as
 - What steps are needed and in what order?
 - Where in the process is effective for finding a particular kind of fault?
 - How can you shape the process to find faults earlier?
 - How can you shape the process to build fault tolerance into a system?

The Quality of the Process (III)

- Models for Process Improvement
 - SEI's Capability Maturity Model (CMM)
 - ISO 9000
 - Software Process Improvement and Capability dEtermination (SPICE)

Business Environment Quality (I)

- The business value being generated by the software system
 - Is it helping the business do things faster or with less people?
 - Does it increase productivity?
- To be useful, the business value must be quantified

Business Environment Quality (II)

- A common approach is to use “return on investment” (ROI)
- Problem: Different stakeholders define ROI in different ways!
 - Business schools: “what is given up for other purposes”
 - U.S. Government: “in terms of dollars, reducing costs, predicting savings”
 - U.S. Industry: “in terms of effort rather than cost or dollars; saving time, using fewer people”
- Differences in definition means that one organization’s ROI can NOT be compared with another organization’s ROI without careful analysis

Software Engineering: More than just Programming

- It should now be clear that software engineering is more than just
 - programming, data structures, algorithms, etc.
- It takes advantage of these very useful computer science techniques but adds
 - quality concerns
 - testing, code reviews, validation and verification of requirements
 - process concerns
 - Are we using the right software life cycle? Are we monitoring our ability to execute the process? Are we consistent? Are we getting better?
- reliance on tools, people, and support processes
 - debugging, profiling, configuration management, deployment, issue tracking

Summary

- In this lecture, we discussed
 - Brooks's definition of a silver bullet
 - A single tool or technique that by itself produces an order of magnitude improvement in the production of software
 - and his argument for why there is no silver bullet for software engineering
- We continued our introduction to the field of software engineering
 - Additional definitions and concerns
 - Challenges faced by the field
 - The importance of quality assurance and why it is difficult to define "quality" for software engineering

SE Conferences

- International Conference on Software Engineering (ICSE)
 - <http://www.icse-conferences.org/>
- International Symposium on the Foundations of Software Engineering (FSE)
- Automated Software Engineering

- Many, many more; See for instance
 - <http://www.sigsoft.org/conferences/listOfEvents.htm>

Professional Societies

- For Computer Science in general
 - ACM: Association for Computing Machinery
 - <http://www.acm.org/>
 - IEEE Computer Society
 - <http://www.computer.org/>
- For Software Engineering
 - ACM Special Interest Group on Software Engineering (ACM SIGSOFT)
 - <http://www.sigsoft.org/>

SE Journals

- The Big Two
 - ACM Transactions on Software Engineering and Methodology
 - <http://tosem.acm.org/>
 - IEEE Transactions on Software Engineering
 - [<http://www.computer.org/portal/web/tse>](http://www.computer.org/portal/web/tse)
- Papers are also available at ACM's and IEEE's digital libraries
 - ACM Digital Library: <http://dl.acm.org/>
 - IEEE Digital Library: <http://www.computer.org/portal/web/csdl>

SE-Related Sites/Blogs

- A great combination: **a good developer with a blog**
 - loudthinking.com; inessential.com; <http://daringfireball.net/>
 - <http://joelonsoftware.com>; <http://ridiculousfish.com/blog/posts.html>
 - <http://www.tbray.org/ongoing/>; scripting.com; <http://blog.wilshiple.com/>
 - <http://jeff-vogel.blogspot.com/>; <http://notch.tumblr.com/>
- More general: slashdot.org; stackoverflow.com; semat.org; [Hacker News](http://hackernews.com)
- **Humor:**
 - xkcd.org, [The Order of the Stick](http://theorderofthestick.com), thedailywtf.com
- Please send me others that you find useful

Coming Up Next

- Lecture 3: Introduction to Software Life Cycles and Agile
- Lecture 4: Introduction to Concurrent Software Systems

- Reading
 - Lecture 4: Chapter 1 of the Concurrency Textbook
 - Lecture 5 and 6: Chapters 1-7 of the User Stories Textbook

- Homework 1 is due by the **start** of Lecture 3 (next Tuesday)
 - See class website for details