

Equalization of Skin Effect Loss Dominated Channels using Pulse-Width Modulation Pre-Emphasis

J.H.R. Schrader, E.A.M. Klumperink, J.L. Visschers, B. Nauta

Abstract— A digital transmitter pre-emphasis technique is presented that is based on pulse-width modulation, instead of finite impulse response (FIR) filtering. The technique fits well to future high-speed low-voltage CMOS processes. A 0.13 μm CMOS transmitter achieves more than 5Gb/s (2-PAM) over 25m of standard RG-58U low-end coaxial copper cable. The test chip compensates for up to 33dB of channel loss at the fundamental signaling frequency (2.5GHz), which is the highest figure compared to literature.

Index Terms— pulse-width, modulation, pre-emphasis, transmitter, equalization, copper

I. INTRODUCTION

High-speed data-communication over lossy copper channels suffers from Inter-Symbol Interference (ISI). In fig. 1a, the magnitude transfer function $|S_{21}|$ of 25m RG-58U low-cost, low-end, standard coaxial cable is shown. It can be seen that the channel exhibits 31dB of loss at the fundamental frequency (2.5GHz) for a 5Gb/s 2-PAM signal. The pulse response of this cable to a 200ps polar Non-Return to Zero (NRZ) pulse (fig. 1b) shows a very long tail that will interfere with neighboring symbols. To compensate, transmitter pre-emphasis and/or receiver equalization is necessary [1,2,3,4]. The latter, receiver equalization, typically involves several analog blocks with speed, accuracy and linearity requirements. On the other hand, transmitter pre-emphasis allows the use of a simple receiver that only needs to sample binary values [4]. Pre-emphasis methods found in literature are commonly based on symbol-spaced finite impulse response (FIR) filtering [1,2,3,4]. In order to flatten the channel response, the transmitted low-frequency amplitude is attenuated to match the loss figure at the fundamental frequency.

In this work, as a proof-of-principle, it will be shown that a very simple pulse-width modulation (PWM) scheme is a good alternative for providing pre-emphasis, as also has been shown by the authors in [9]. A similar technique was recently proposed by the authors' group for on-chip communication over 1cm long RC-limited interconnects [5]. Our paper

demonstrates the suitability of the PWM technique for transmission over $\sim 25\text{m}$ low-end copper cables. This PWM pre-emphasis method for copper cables can achieve a loss compensation of 33dB at 5Gb/s, which is the highest figure compared to those found in literature.

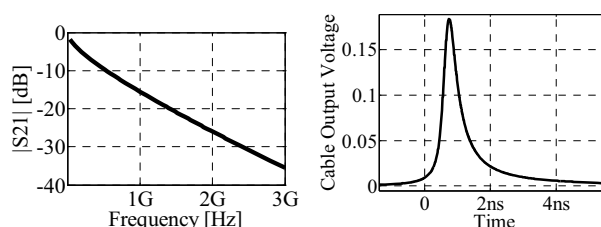

Fig. 1a (left): $|S_{21}|$ of 25m RG-58U low-cost, low-end standard coaxial cable. Fig 1b (right): Cable response to a 200ps pulse.

II. PULSE-WIDTH MODULATION PRE-EMPHASIS

A 2-PAM transmitter without pre-emphasis would send only a plain polar NRZ pulse for every bit. However, the cable smears out the pulses (as shown in fig. 1b), leading to ISI. To compensate, a 2-tap symbol-spaced FIR filter sends a delayed (lower amplitude) inverse polarity pulse after each main NRZ pulse (during the next bit time). Loosely speaking, this inverse polarity pulse compensates for the energy in the long tail of the cable response, leading to a much narrower cable output pulse than for the transmitter without pre-emphasis. These 2-tap symbol-spaced FIR filters are easy to implement and generally used for pre-emphasis [1,3,4]. We observed that similar functionality might be obtained using a fixed amplitude, but variable (time-)width inverse pulse. In fig. 2 the TX waveform for the presented PWM-PE filter is shown. Bit values, polar NRZ and Manchester coded waveforms are also shown in the same figure. The PWM pulse shape resembles a Manchester coded signal, but where the duty-cycle of Manchester is fixed at 50%, the PWM signal instead has a tunable duty-cycle. Therefore a value of 100% corresponds to transmission of a normal (polar NRZ) data signal (no pre-emphasis), and 50% to transmission of a Manchester coded data signal (max. pre-emphasis setting). The optimum duty-cycle is somewhere in between, depending on the channel characteristics.

To see the resulting cable response, simulations have been made with an accurate cable model that includes skin effect and dielectric loss [7,8]. Results are shown in fig. 3 (3a: cable input, 3b: simulated output for 25m RG-58U). Note that, for

J.H.R. Schrader, E.A.M. Klumperink and B. Nauta are with MESA+ Research Institute, IC Design Group, University of Twente, P.O.Box 217, 7500AE Enschede, The Netherlands (phone: +31-53-4892643; fax: +31-53-4891034; e-mail: j.h.r.schrader@utwente.nl).

J.L. Visschers is with the National Institute for Nuclear Physics and High Energy Physics, P.O. Box 41882, 1009 DB Amsterdam, The Netherlands.

the correct duty-cycle setting, the cable output pulse becomes much narrower than the response to a plain polar NRZ pulse. Second, note that, as can be seen from fig. 3, the optimum duty-cycle is in-between 50% and 100%.

The PWM method does not tune the pulse amplitude (as for FIR pre-emphasis), but instead exploits timing resolution. This is beneficial in future high-speed low-voltage CMOS generations, and it allows (class-D) full switching to the supply voltages. Second, the implementation is very simple and can be low-area, low-power and digital. In comparison to 2-tap symbol-spaced FIR filters the PWM scheme has a higher switching frequency (due to the switching inside the symbol period) and spectral analysis shows that it achieves more high-frequency boost than 2-tap symbol-spaced filters, resulting in higher loss compensation.

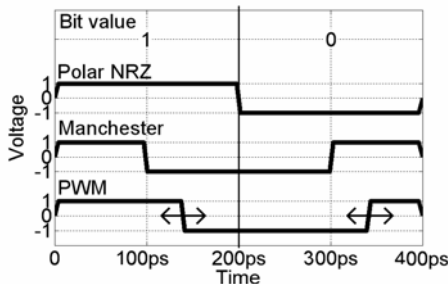

Fig. 2. TX signal for PWM-PE, $T_s=200ps$

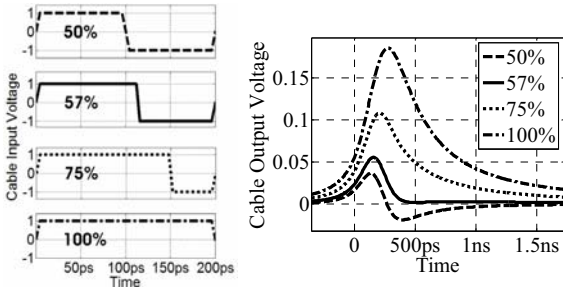

Fig 3a (left): PWM cable input pulse shapes for varying duty-cycles (200ps symbol duration). Fig 3b (right): Simulated cable responses (25m RG-58U) to PWM pulse shapes.

III. CIRCUIT IMPLEMENTATION

A prototype circuit has been designed as a proof-of-concept. As shown in fig. 4, the pre-emphasis circuit XORs the data with a pulse-width modulated (PWM) clock in order to provide pre-emphasized data. The PWM clock is generated using an OR gate and a delay circuit.

In fig. 5 the chip diagram is shown. Because a small differential delay is easier to make than a short absolute delay, the relative delay for clock B is created by delaying $clk1$ with $delay1$ and delaying $clk2$ with $delay2$. The differential delay is thus equal to $(delay1 - delay2)$ and controllable by voltage $V_{delay1} - V_{delay2}$. (Both are differential voltages). The XOR is implemented using a multiplexer (fig. 6a) that selects either $D1$ (non-inverted data) or $D2$ (inverted data) [5]. For optimum timing margin, $D2$ is delayed half a symbol time using a negative edge clocked flip-flop. The duty-cycle of the PWM pulse shape can be tuned between 50%-100%, when the relative phase-shift between clocks is $0^\circ - 180^\circ$.

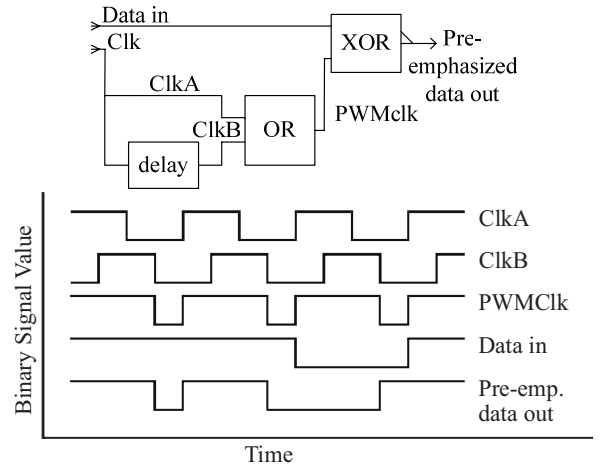

Fig. 4a (top): operation principle. Fig 4b (bottom): signals.

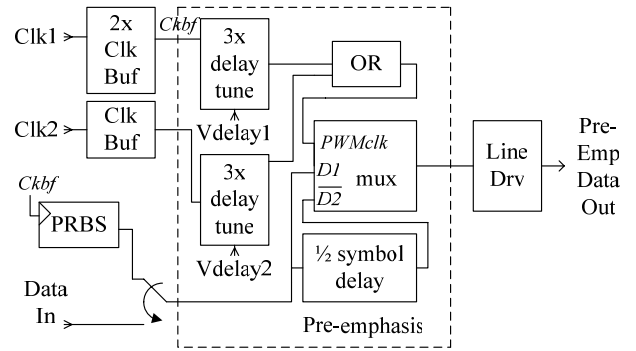

Fig. 5 Chip diagram: PRBS generator, clock buffers, pre-emphasis circuit and line driver. (All signals are differential).

A. Delay Circuit

The time-shifted clock is generated using a variable delay circuit (fig. 6b) [6]. This circuit has a delay from in to out, which is mainly determined by the RC time at the output. By adding a negative resistance (positive feedback circuit in parallel to the output), the effective R can be changed and hence the RC-delay. The value of the negative resistance is controlled by the differential delay control voltage V_{delay} ($=V_{delP} - V_{delN}$), which divides the total bias current between the input differential pair and negative resistance pair. For $V_{delP} \gg V_{delN}$, the delay is minimized. As the total bias current through the output resistors is fixed, the output swing remains constant. The required tuning range of the delay-circuit depends on the desired symbol length and on the necessary duty-cycle range for pre-emphasis. The (continuous) tuning range can be enlarged by cascading multiple delay stages. For very large delay ranges this becomes unpractical and it is more effective to combine (continuous tunable) delay with (discrete fixed) delay steps. The prototype design is designed for flexibility to evaluate the new PWM-concept in various ways. Therefore external clocks can be provided, e.g. to accommodate for very low bit rates for long poor cables. During normal operation, both inputs $clk1$ and $clk2$ (fig. 5) can just be connected to the same clock.

The whole test chip has been designed in CML to provide maximum supply noise rejection and minimum supply noise injection and keep timing noise as low as possible. Also, this guarantees equal up- and down- slew rates.

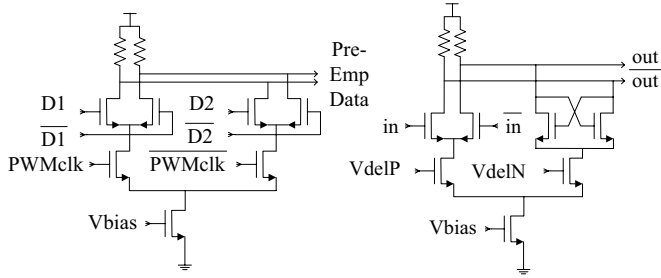

Fig. 6a (left): CML multiplexer. Fig. 6b (right): CML delay tuning.

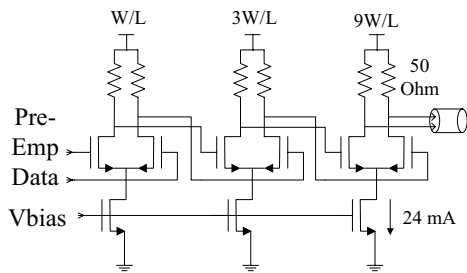

Fig. 7 Three-stage differential line driver.

B. Line Driver

The line driver (fig. 7) consists of three stages. Each stage has three times the W/L dimensions and one third the resistance value of its predecessor. The final stage has 50 Ω on-chip output resistance and a tail current of 24mA. Nominal single-ended output swing is 600mV_{p-p} (Differential 1.2V_{p-p}).

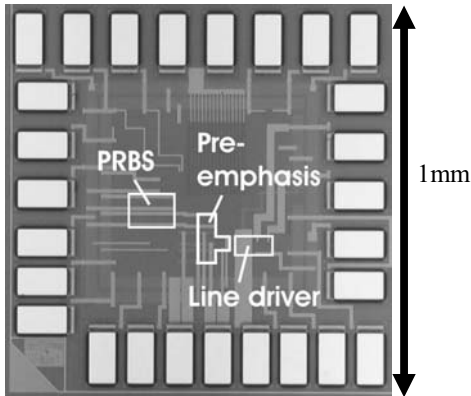

Fig. 8 Chip microphotograph.

IV. MEASUREMENTS

A microphotograph of the chip is shown in fig. 8. To evaluate the performance of the prototype chip, a number of measurements have been made. First, eye diagrams were generated, to provide a first order estimation of the signal integrity and to see the effect of adjusting the duty-cycle setting. Second, BER measurements were made to evaluate the robustness and reliability of the transmitter. All measurements have been made using standard RG-58U

coaxial cable, using only one of the two transmitter outputs and terminating the other at 50 Ω . The cable was connected to the test chip using a 50 Ω differential probe (with 4 pins: ground-signal-signal-ground). The RG-58U cable is a very low-cost, low-end cable.

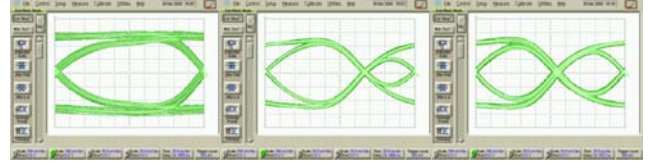

Fig. 9a,b,c Measured transmitter eyes at 5Gb/s with three different duty-cycle settings; left: no pre-emphasis (100%), middle: weak pre-emphasis (66%), right: strong pre-emphasis (55%). Horizontal axis = 20ps/div, vertical axis=100mV/div.

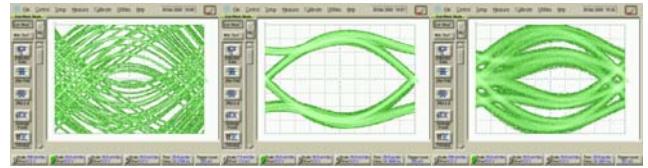

Fig. 10a,b,c Measured eyes of cable response for transmitter settings shown in previous figure and 5Gb/s over 10m RG-58U cable. Horizontal axis = 20ps/div, vertical axis=20mV/div.

Although the transmitter is fully differential, unfortunately no high speed differential cable assemblies were available so differential measurements could not be carried out. A 2⁷-1 PRBS input pattern has been used for the measurements. All chip I/Os have on-chip 50 Ω termination and are ESD protected.

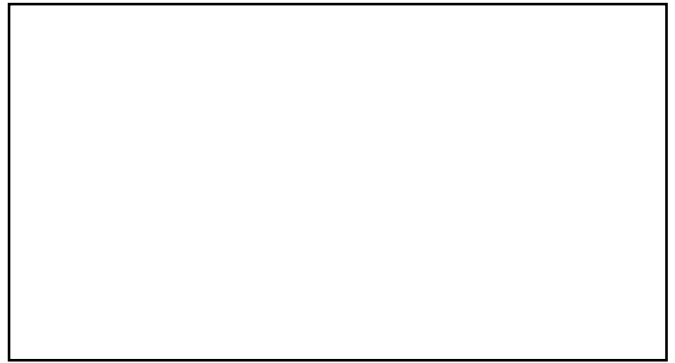

Fig. 11: Effect of adjusting TX duty-cycle for 3Gb/s over 10m RG-174U cable. Green line: TX output, yellow line: cable output.

A. Effect of Adjustments in PWM Duty-Cycle

In fig. 9, the effect of adjusting the duty-cycle of the PWM-PE filter can be seen. The transmitter output eyes are shown for different duty-cycles. The left- and right edges in the eye diagrams correspond to the symbol edges. In fig. 10 the responses of a 10m RG-58U cable to the pre-emphasized data stream with different pre-emphasis duty-cycles are shown. It can be seen that there is an optimum duty-cycle (fig. 10b). Under-emphasis is shown in fig. 10a and over-emphasis in fig. 10c. Note that the time scale in fig. 9 and 10 is the same. The pre-emphasis leaves the fastest pattern unchanged while it attenuates the slower transitions. In fig. 11, a video is shown

of the effect of adjusting the TX duty-cycle on the eye diagrams.

B. Eye Diagrams at Max. Loss Compensation

In fig. 12a (4Gb/s) and fig. 12b (5Gb/s), measured eye diagrams of the cable output for 25m RG-58U are shown, using the on-chip 2^7-1 PRBS pattern generator. These two speeds are shown to illustrate the difference in eye shape. Shown in fig. 18, the cable loss at 2.5GHz is 31dB, and the total channel loss is approximately 33dB including additional parasitic losses in the path from chip to coaxial cable (probes, short wire, bias tee and connectors). The BER has been tested up to 5Gb/s (using an external 2^7-1 PRBS pattern generator) and is $<10^{-12}$. It can be concluded that the pre-emphasis compensates enough channel loss to enable error free transmission at 5Gb/s.

At a channel loss of 33dB, the small cable output amplitude puts a high demand on receiver sensitivity and it might be necessary to use differential signaling. Using the fully differential transmitter capabilities would boost the (differential) swing at the cable output with 6dB while also rejecting common mode noise.

In table I, a comparison with other published work is given. In [1], a combination of pre-emphasis and post-equalization has led to 27dB (18dB+9dB) loss compensation at a signaling rate of 5Gb/s. Here, “loss compensation” is defined as cable loss (in dB from the S_{21}) at the fundamental frequency (e.g. 2.5GHz for a 5Gb/s signaling rate), at which low error transmission is still possible. None of the pre-emphasis filters that use 2 taps [1,3,4] offer more than 18dB loss compensation. A 5-tap FIR filter in [2] reaches 30dB but only at 3.125Gb/s. More taps can offer higher loss compensation but at the cost of increasing complexity, possibly causing accuracy and speed issues. Furthermore, the process of finding the optimum equalizer coefficients will be more complicated than for a single-coefficient equalizer. The single-coefficient PWM-PE filter offers the highest loss compensation (33dB) at a bit rate of 5Gb/s.

In table II, the electrical characteristics are given. Power dissipation is hard to compare because most publications only give total figures. In the current proof-of-concept design, the clock-buffering takes quite a lot of the power budget, which can be improved if internal clocks are available in the IC, like in practical applications. Because of the simplicity of the pre-emphasis method, area and power can be very small.

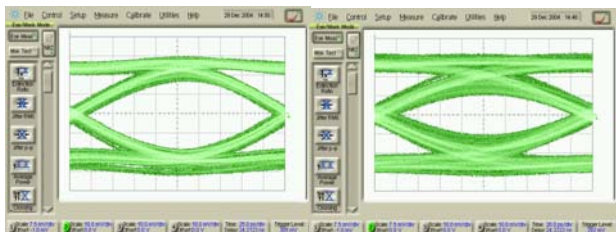

Fig. 12a (left): Measured output eye of 25m RG-58U at 4Gb/s. Horizontal axis = 20ps/div, vertical axis = 10mV/div. Fig. 12b (right): Measured output eye of 25m RG-58U at 5Gb/s. Horizontal axis = 20ps/div, vertical axis = 7.5mV/div.

TABLE I
PRE-EMPHASIS COMPARISON WITH OTHER WORK

Ref.	R	Loss	Ft. size	Type
[1] TX only	5Gb/s	18dB	0.13 μ m	2-tap FIR
[2] TX only	3.125Gb/s	30dB	0.11 μ m	5-tap FIR
[3]	8Gb/s	\sim 10dB	0.3 μ m	2-tap FIR
[4]	4Gb/s	\sim 10dB	0.25 μ m	2-tap FIR
this work	5Gb/s	33dB	0.13μm	PWM

From [1,2] only the transmitter pre-emphasis has been taken into account (not the receiver equalizer).

TABLE II
ELECTRICAL CHARACTERISTICS OF TRANSMITTER

Baudrate (2-PAM)	5GBd
U-I	200ps
TX amp. (V_{p-p}) nom.	1.2V (dif), 600mV (single-ended)
Channel loss @ 2.5GHz	33dB
V_{sup}	1.2V
Power (pre-emphasis)	12mW
Power (line driver)	42mW
Power (clock buffering)	39mW
Power (on-chip PRBS)	17mW

V. CONCLUSIONS

A new digital pre-emphasis technique based on pulse-width modulation (PWM) is introduced. The PWM method does not tune the pulse amplitude (as for FIR pre-emphasis), but instead exploits timing resolution. This fits well to future low-voltage high-speed CMOS processes. Using only single-ended measurements due to limitations in measurement equipment, successful transmission of a 2-PAM 5Gb/s data signal over 25m of low-cost, low-end, standard RG-58U coaxial cable is demonstrated. This corresponds to a loss compensation of 33dB at the fundamental frequency of 2.5GHz, which is the highest figure compared to literature on 2-tap FIR pre-emphasis filters. The PWM pre-emphasis filter can be adjusted to the cable using only a single coefficient (the duty-cycle). Main building blocks of the CML pre-emphasis circuit are a tunable delay, an OR gate and a multiplexer. The pre-emphasis technique is simple and can be implemented using only low power and area.

ACKNOWLEDGEMENT

The authors would like to thank Stichting FOM for funding.

REFERENCES

- [1] Y. Kudoh, M. Fukaishi and M. Mizuno, “A 0.13- μ m CMOS 5-Gb/s 10-m 28AWG cable transceiver with no-feedback-loop continuous-time post-equalizer”, *IEEE J. Solid-State Circuits*, vol. 38, pp. 741-746, May 2003.
- [2] W. Gai, Y. Hidaka, Y. Koyanagi, J.H. Jiang, H. Osone and T. Horie, “A 4-channel 3.125 Gb/s/ch CMOS transceiver with 30dB equalization”, *Symposium on VLSI Circuits, Digest of Technical Papers*, pp. 138-141, 2004.

- [3] R. Farjad-Rad, C.K. Yang, M. Horowitz, and T. Lee, "A 0.3- μm CMOS 8Gb/s 4-PAM serial link transceiver", *IEEE J. Solid-State Circuits*, vol. 35, pp. 757-764, May 2000.
- [4] M. Lee, W. Dally and P. Chiang, "Low-power area-efficient high-speed I/O circuit techniques", *IEEE J. Solid-State Circuits*, vol. 35, pp. 1591-1599, Nov. 2000.
- [5] D. Schinkel, E. Mensink, E. A. M. Klumperink, A. J. M. van Tuijl and B. Nauta, "A 3Gb/s/ch Transceiver for RC-limited On-Chip Interconnects," *IEEE Int. Solid-State Circuits Conf. (ISSCC) Dig. Tech. Papers*, pp. 386-387, Feb. 2005.
- [6] B. Razavi, "Design of analog CMOS integrated circuits", McGraw-Hill, 2001.
- [7] F.E. Gardiol, "Lossy transmission lines", Artech House, 1987.
- [8] P. Grivet and P. W. Hawkes, "The physics of transmission lines at high and very high frequencies", Academic Press, 1970.
- [9] J.H.R. Schrader, E.A.M. Klumperink, J.L. Visschers and B. Nauta, "CMOS Transmitter using Pulse-Width Modulation Pre-Emphasis achieving 33dB Loss Compensation at 5-Gb/s", *2005 Symposium on VLSI Circuits, Digest of Technical Papers*, pp. 388-391, June 2005.