

# Behavioral Components of Impulsivity

Christoph Stahl  
University of Cologne

Andreas Voss  
Ruprecht-Karls-University Heidelberg

Florian Schmitz and Mandy Nuszbaum  
Albert-Ludwigs-University Freiburg

Oliver Tüscher and Klaus Lieb  
Albert-Ludwigs-University Freiburg and Johannes-Gutenberg-  
University Mainz

Karl Christoph Klauer  
Albert-Ludwigs-University Freiburg

Acting in accord with long-term goals requires control of interfering impulses, the success of which depends on several different processes. Using a structural-equation modeling approach, we investigated 5 behavioral components of impulsivity: the control of stimulus interference, proactive interference, and response interference, as well as decisional and motivational impulsivity. Results support the existence of 5 correlated but separable components of impulsive behavior. The present study is the 1st to demonstrate the separability of stimulus and response interference. It also supports the notion that control of response-related interference is not a unitary construct: Response-selection demands were separable from those of withholding or stopping. Relations between behavioral impulsivity components and self-report measures of impulsivity were largely absent. We conclude that as the construct of impulsivity has been extended to describe an increasingly diverse set of phenomena and processes, it has become too broad to be helpful in guiding future research.

*Keywords:* impulsivity, impulse control, distracter interference, proactive interference, response interference

Impulsivity is central to many aspects of human cognition and behavior. The requirement to control interfering stimuli, thoughts, or response tendencies shapes our daily lives, our cognitions, and our behaviors in a variety of ways. For example, while driving to work, our ability to do so safely may be diminished by a disrupting phone call, by an intruding or distracting thought or memory, or by

the delicious scent of coffee tempting us to reach for the cup. Spontaneous behaviors that are triggered by such internal or external stimuli or response tendencies and that are incompatible with long-term goals are often called impulsive.

The ability to control our impulses is fundamental to individual and social functioning and has been discussed in a wide range of contexts, including abnormal psychology, cognitive psychology, developmental psychology, neurogenetics, psychopharmacology, and social psychology (Congdon & Canli, 2008; Evenden, 1999; Hasher, Lustig, & Zacks, 2007; Heatherton & Wagner, 2011; Kagan, 1966; Mischel et al., 2011; Nigg, 2000; Ridderinkhof, Forstmann, Wylie, Burle, & van den Wildenberg, 2011; Strack & Deutsch, 2004). Impulsivity, when characterized as the failure to resist a drive or impulse potentially harmful to the self or others, is a core feature of several psychiatric disorders, including attention-deficit/hyperactivity disorder (ADHD; Barkley, 1997; Nigg, 2010), autism (Christ, Kester, Bodner, & Miles, 2011), borderline personality disorder (Nigg, Silk, Stavro, & Miller, 2005), depression (Carver, Johnson, & Joormann, 2008; Joormann, Yoon, & Zetsche, 2007), obsessive-compulsive disorder (Enright & Beech, 1993; Fineberg et al., 2010), substance abuse (Clark, Robbins, Ersche, & Sahakian, 2006; Dick et al., 2010; Groman, James, & Jentsch, 2009; Verdejo-García, Lawrence, & Clark, 2008), as well as impulse-control disorders such as trichotillomania or pathological gambling (Chamberlain & Sahakian, 2007; A. J. Lawrence, Luty, Bogdan, Sahakian, & Clark, 2009).

---

This article was published Online First August 19, 2013.

Christoph Stahl, Department of Psychology, University of Cologne, Cologne, Germany; Andreas Voss, Institute of Psychology, Ruprecht-Karls-University Heidelberg, Heidelberg, Germany; Florian Schmitz and Mandy Nuszbaum, Institute of Psychology, Albert-Ludwigs-University Freiburg, Freiburg im Breisgau, Germany; Oliver Tüscher and Klaus Lieb, Department of Psychiatry and Psychotherapy, Albert-Ludwigs-University Freiburg, Freiburg im Breisgau, Germany, and Department of Psychiatry and Psychotherapy, Johannes-Gutenberg-University Mainz, Mainz, Germany; Karl Christoph Klauer, Institute of Psychology, Albert-Ludwigs-University Freiburg, Freiburg im Breisgau, Germany.

Florian Schmitz is now at the Institute of Psychology and Education, University of Ulm, Ulm, Germany. Mandy Nuszbaum is now at the GfK Group, Nuremberg, Germany.

This research was supported by German Federal Ministry of Education and Research Grant 01GW0730 to Christoph Stahl, Andreas Voss, Oliver Tüscher, Klaus Lieb, and Karl Christoph Klauer. We thank Alexandra Sebastian for helpful comments on an earlier version of this article.

Correspondence concerning this article should be addressed to Christoph Stahl, Department of Psychology, University of Cologne, Herbert-Lewin-Str. 2, D-50931 Köln, Germany. E-mail: christoph.stahl@uni-koeln.de

In stark contrast to its widespread clinical importance and direct mentioning or indirect implication as diagnostic criterion in both the *Diagnostic and Statistical Manual of Mental Disorders* (4th ed.; *DSM-IV*; American Psychiatric Association, 1994) and the *International Classification of Diseases—10* (ICD-10; World Health Organization, 2010) and despite a large number of attempts at integrating impulsivity research (a PubMed search yielded 284 reviews or meta-analyses), there is no explicit definition of impulsivity in the clinical domain (e.g., Moeller, Barratt, Dougherty, Schmitz, & Swann, 2001). In addition to the lack of a clear definition of impulsivity, the divergence between different methods to assess impulsivity becomes increasingly evident (e.g., Cyders & Coskunpinar, 2011). In borderline personality disorder (BPD), for example, impulsivity is a major diagnostic criterion and is thought to play an essential role in neurobehavioral models of the disease, and patients show elevated self-reported impulsivity (e.g., in the Barratt Impulsiveness Scale [BIS-11]; Barratt & Patton, 1995; Patton, Stanford, & Barratt, 1995) when compared to both healthy and clinical control groups (Berlin & Rolls, 2004; Domes et al., 2006; Jacob et al., 2010). However, well-controlled studies investigating performance on behavioral motor or cognitive impulse control tasks such as Stop or Go/No-Go tasks or the Stroop test generally render mixed results: Whereas some studies found performance deficits in Go/No-Go tasks (Leyton et al., 2001; Rentrop et al., 2008), the majority of studies did not (Jacob et al., 2010, 2013; Lampe et al., 2007; LeGris, Links, van Reekum, Tannock, & Toplak, 2012; Ruchow et al., 2008; Völker et al., 2009). Recent behavioral studies suggest that general deficits in patients with BPD may exist on the motivational level in domains such as decision making and delay of gratification (K. A. Lawrence, Allen, & Chanen, 2010; Schuermann, Kathmann, Stiglmayr, Renneberg, & Endrass, 2011; Völker et al., 2009). Some studies showed emotional modulation of performance in motor or cognitive tasks related to impulse control (Chapman, Leung, & Lynch, 2008; Domes et al., 2006; Silbersweig et al., 2007). Yet, other studies suggest that behavioral measures of inhibitory control may be altered by comorbid disorders such as ADHD but not by BPD itself (which seems to be especially true for response inhibition; Lampe et al., 2007; Nigg et al., 2005). A recent review (Sebastian, Jacob, Lieb, & Tüscher, 2013) thus concludes that impulse control is not generally affected in BPD. Rather, it seems that impulsive behaviors in BPD may appear only in certain subdomains of impulse control or may be secondary to comorbid ADHD or dysregulation of BPD salient emotions. Hence, using BPD as a prominent example of a disorder clinically characterized by impulsive behaviors, there seems to be only poor convergence of self-report and behavioral measures of impulsivity, perhaps due to the heterogeneous nature of the set of phenomena that are characterized as impulsive.

Given the variety of relevant behaviors and contexts, and the dissimilarity of postulated psychological processes or functions as well as outcomes, today most authors agree that impulsivity—or, inversely, the control of interfering impulses—is not a unitary construct (and perhaps not a construct at all; see Cyders & Coskunpinar, 2011; Enticott & Ogloff, 2006). Impulsivity, and impulse control, consists of several facets, each of which may have several subcomponents (Evenden, 1999). Different brain systems and neurochemical mechanisms have been implicated in impulse control, indicating that impulse control has no single neurobiological basis

(Munakata et al., 2011). The variety of facets has been characterized in different ways; several taxonomies of the components of impulsivity and impulse control, as well as the closely related concepts of interference control and inhibition, have been proposed (see Nigg, 2000, for an overview). Moeller et al. (2001) have suggested that disagreements in the literature on how to define and measure impulsivity lead to a lack of specificity regarding the role of impulsivity in psychiatric illness. The authors stated the need for an “ideologically neutral” model of impulsivity which may be tested by refined measures of impulsive behavior. This call to differentiate, behaviorally as well as neurally, between different forms or components of impulsivity to help identify disease-related endophenotypes (or bio-markers) has recently been re-instated by Dalley, Everitt, and Robbins (2011) and Fineberg et al. (2010). Impulsivity is, they concur, a multifaceted construct—with different aspects of interference control (i.e., response interference), most likely “mediated by related, but distinct, neural circuitry linked with motivational and decisional processes” (Dalley et al., 2011, p. 680). These behavioral indicators of impulsivity appear to be only weakly related to self-reported impulsivity (Cyders & Coskunpinar, 2011). In an attempt to present a more complete model of behavioral impulsivity, the present work aims at refining behavioral measures of interference control as well as integrating decisional and motivational factors.

### Rationale for a Five-Component Model of Behavioral Impulsivity

More recently, central facets of impulsivity have been distinguished by many researchers in very similar ways, such that a largely convergent higher-level picture is emerging. Recent theoretical and empirical research on impulsivity, impulse control, and inhibitory function suggests the existence of at least three major components of interference control, comprising control of stimulus interference, proactive (i.e., mental-representation) interference, and response interference: Goal-directed behavior may be interfered with by stimuli that are encountered in the environment, by stimulus representations in memory, or by involuntarily activated or prepotent response tendencies (Evenden, 1999; Friedman & Miyake, 2004; Hasher et al., 2007; Nigg, 2000). The requirement to control interference from external stimuli, internal representations, and response tendencies is at the core of impulse control and is closely related to motivational processes (e.g., Nigg, 2000), such as the delay of gratification (Mischel et al., 2011). Furthermore, any decision to respond or to withhold a response is affected by decision-making style as another integral component of impulse control; decisions can be made either spontaneously and impulsively, or through deliberation and reflection (Bechara, 2005; Kagan, 1966).

As outlined above, successful impulse control requires the interplay of several different processes at different steps in the perception-action cycle, or on different levels of the cognitive system (Badre, 2008; Fuster, 2004; Hasher et al., 2007; Mischel et al., 2011; Nee, Wager, & Jonides, 2007; Nigg, 2000). Impulse control can be conceived as the set of processes that enable individuals to decide upon a set of long-term goals, and to maintain and pursue these goals without being disrupted by interfering impulses. (1) Motivational processes contribute to goal selection by influencing subjective assessments of value and reward; impul-

sive behavior, driven by the temptation of short-term reward, may interrupt long-term goals to the degree that delayed rewards are discounted (delay discounting [DD]). (2) Decision-making styles affect the quality of goal selection as well as decisions on when and how to act, for instance by determining the amount of information that is considered and reflected upon; impulsive decision-making is characterized by a liberal decision criterion implying that only small amounts of information are considered prior to the decision (information sampling [IS]). (3) During goal pursuit, selective attention to goal-relevant stimuli is required to avoid distraction. Stimuli in the environment that are irrelevant to the current task or goal, such as a ringing phone while driving, are potentially distracting: They might reorient our attention, leading to subsequent deletion of an important task or goal from prospective memory, or initiation of interfering response tendencies (stimulus interference [SI]). (4) Similarly, the ability to selectively attend to goal-relevant cognitions or mental representations—and to ignore or suppress goal-irrelevant cognitions or representations—is required to avoid distraction and to maintain a successful pursuit of the current goal (proactive interference [PI]). (5) Finally, the ability to resolve response competition is required to select and execute the appropriate actions. Task-irrelevant or incompatible response tendencies may be activated involuntarily and may interfere with goal pursuit (response interference [RI]). Theoretically as well as empirically, the ability to resolve response competition may be dissociable from the traditional concept of behavioral inhibition, which refers to the ability to withhold or interrupt a prepotent or ongoing response.

Table 1 presents an overview of the behavioral components of impulsivity considered in the present study and their counterparts in previous research. This study presents a latent-variable analysis of these five components of impulsive behavior and their relation to self-reported impulsivity. To clarify the scope of the present study, the selection of constructs described above is not intended to represent a complete model of impulsivity and impulse control; for instance, Cyders and Coskunpinar (2011) identified distorted judgments of elapsed time as another facet of behavioral impulsivity, one that is not considered here. Furthermore, the selected constructs are, in all likelihood, not exhaustively represented by the respective set of indicator tasks; for instance, motivational aspects are not fully captured by delay discounting (e.g., Sergeant, 2000). Despite these limitations, the present study is one of the most comprehensive latent-variable investigations of the facets underlying impulsive behavior, as well as their relations with self-reported impulsivity (which was expected to be low; see Cyders & Coskunpinar, 2011). These facets and their relations are discussed next in more detail.

## Interference Control

Interference control refers to the ability to resolve conflict that may arise from different sources (i.e., stimuli, thoughts, and actions). In cognitive psychology, its components have often been studied under the label of inhibition or inhibitory control (Aron, 2007; Friedman & Miyake, 2004; Hasher et al., 2007; Miyake et al., 2000; Munakata et al., 2011; Nigg, 2000). In a seminal study, Miyake et al. (2000) have established inhibition as one of three executive functions, along with shifting and updating. Friedman and Miyake (2004) then investigated the relation between subcom-

ponents of inhibition and interference control. They considered the three factors of Distracter Interference, Response Inhibition, and Proactive Interference (see Table 1) and found that Distracter Interference and Response Inhibition were closely related and not separable in their study, whereas Proactive Interference proved to be a distinct component that could be separated from the other two.

A similar tripartite view of inhibition also emerged in research on cognitive aging. Based on their inhibition-deficit hypothesis of cognitive aging (Hasher et al., 2007; Hasher & Zacks, 1988), Hasher et al. (2007) have put forward a theory of inhibition as a fundamental cognitive function that underlies most other cognitive abilities. In their theory, behavioral inhibition—termed restraint—is one of three components of inhibition, along with access control (i.e., preventing irrelevant stimuli from accessing working memory), and deletion (i.e., preventing memory contents that were once relevant from interfering with current task demands). Age-related variability has been demonstrated for a number of tasks that are thought to reflect these three inhibitory abilities. Close relations exist between Hasher et al.'s components and those investigated by Friedman and Miyake (2004): The restraint construct can be mapped onto the inhibition of prepotent responses as investigated by Friedman and Miyake; the deletion component can be mapped onto the ability to resist proactive interference; and the access component can be mapped onto the ability to avoid interference from distracting stimuli. Table 1 relates the taxonomies of inhibitory constructs introduced by Friedman and Miyake, Hasher et al., and Nigg (2000).<sup>1</sup>

One goal of the present study is to investigate these three components of interference control (see Table 1) and their relations. Specifically, extending previous work, we aim to show that the three components can be separated empirically. Another goal is to investigate response-related control in more detail and to test whether it may be better described as consisting of (at least) two separate components, as suggested by recent theoretical and empirical work (e.g., Aron, 2011; Sebastian, Pohl, et al., 2013).

## Relations Between Interference Control Components

As illustrated by Table 1, there is high theoretical convergence concerning the postulated components of interference control. However, due to the absence of conclusive empirical data, there is still disagreement as to the separability of these interference control components (Friedman & Miyake, 2004; Hasher et al., 2007; Nigg, 2000; Salthouse, 2005). As a case in point, in the study by Friedman and Miyake (2004), the latent factors representing the Distracter Interference and Response Interference functions were highly correlated; in fact, a model that combined them into a single Response-Distracter Interference factor was better able to account for the data, which led the authors to conclude that both functions, while conceptually clearly distinct, were not empirically separable in their study. The Response-Distracter Interference factor was,

<sup>1</sup> The term *inhibition* has been criticized because it conflates the description of an outcome (e.g., the withholding of a response) with theoretic assumptions about the processes leading to that outcome (e.g., inhibition of nodes in associative or neural networks); this is unfortunate because what looks like inhibitory control can also result from activation processes (for recent review, see Aron, 2007; Munakata et al., 2011). Here, the term *inhibition* is used only descriptively.

Table 1

Overview of Behavioral Components of Impulsivity Considered in the Present Study and Their Counterparts in Cyders and Coskunpinar (2011), Friedman and Miyake (2004), Hasher et al. (2007), and Nigg (2000)

Present study	Nigg (2000)	Friedman & Miyake (2004)	Hasher et al. (2007)	Cyders & Coskunpinar (2011)
Stimulus interference (SI)	Interference control	Distracter interference	Access	Distracter interference
Proactive interference (PI)	Cognitive inhibition	Proactive interference	Deletion	Proactive interference
Response interference (RI)				
Behavioral inhibition (BI)	Behavioral inhibition	Response inhibition	Restraint	Prepotent response inhibition
Information sampling (IS)				
Delay discounting (DD)				Delay response

however, separable from a distinct proactive interference factor; a finding that we expected to replicate.

One of the goals of the present study was to investigate whether this finding of a strong relation would replicate. Our hypothesis was that SI and RI are related but separable components of interference control. This hypothesis was derived from two observations: First, a reanalysis of the data from Friedman and Miyake (2004) suggests that the relation between RI and SI may have been artificially increased by commonalities of the Stroop and Flanker tasks (see also the Results and Discussion sections); in our view, the Stroop and Flanker tasks are similar in that they involve both distracter- and response-related interference. Second, recent behavioral and neuroimaging studies support the notion that three interference control functions can be separated (Badre, 2008; Casey et al., 2000; Nee, Wager, & Jonides, 2007). In short, the relations that are sometimes observed between stimulus interference and response interference may not reflect the fact that both types of interference are resolved by a single underlying process, but may instead be due to the fact that typical tasks involve not only stimulus interference but also response-related interference (for a discussion for the Stroop and Flanker tasks, see the General Discussion section).

A second goal was to investigate response-related interference more closely. On the one hand, many relevant tasks involve two competing but equipotent responses, one of which may be involuntarily activated by a task-irrelevant prime or distracter, thereby interfering with response *selection*. On the other hand, other tasks do not require interference control processes to operate at the stimulus discrimination or response selection stages, but instead ask participants to *withhold*, *modify*, or *stop* an already selected response. For example, Stop-Signal tasks typically involve executing a simple response that has then to be aborted on some trials, an ability that has been termed *behavioral inhibition* (BI; see Table 1). In the present study, we focus on the ability to resolve interference during the *selection between competing responses*. We propose that processes of interference resolution at the (earlier) response-selection stage may be dissociable from those involved in later stages of withholding or stopping a response—and, furthermore, that both of these components, response-selection as well as behavioral inhibition, can be dissociated from stimulus-related interference.

### Decisional and Motivational Impulsivity

Whereas the relevance of interference control processes is obvious in “cold” cognitive tasks, a similar set of processes has been suggested as critical for resolving conflict in “hot” appetitive or

tempting situations. A recent review of the delay-of-gratification research by Walter Mischel and coworkers (Mischel et al., 2011) suggests the blocking of unwanted information (i.e., SI), the suppression of unwanted thoughts (i.e., PI), and the suppression of responses (i.e., RI or BI) as possible underlying determinants of the ability to resist temptation. Delay discounting is thought to reflect the failure to endure a delay before a reward is obtained, similar to delay-of-gratification demands (Mischel et al., 2011). More specifically, delay-discounting reflects the preference for immediate over delayed reward, an important aspect of impulsivity that has been implied in a wide variety of complex behaviors (Mischel et al., 2011; Peters & Büchel, 2011). In addition, goal selection is influenced by individuals’ subjective assessments of the value of a given reward, which is affected by their delay-discounting tendency (Green & Myerson, 2004; Metcalfe & Mischel, 1999; Peters & Büchel, 2011; Reynolds, 2006).

Individuals may also vary in their tendency to rely on reflection, or to fully consider the available information, when making decisions or selecting goals (Kagan, 1966). Criterion setting varies across persons, and is hypothesized to be related to impulsivity. Specifically, high impulsivity is assumed to be associated with a relatively liberal criterion: When a person seeks only a small amount of information, an impulsive decision is made (Bechara, 2005). Low levels of impulsivity are associated with a more cautious criterion: Reflective decisions are based on larger amounts of information (Verdejo-García et al., 2008). Recent evidence from cognitive neuroscience studies showed a tight relation of decision making abilities and response interference (Steinbeis, Bernhardt, & Singer, 2012) in general and—in clinical behavioral studies—specifically for reflection impulsivity and interference control (Verdejo-García et al., 2008), although the exact nature of this link is not known. Moreover, another line of research implied a similar close link between motivational and decisional processes within frontal brain regions (Hare, Camerer, & Rangel, 2009). To complete our understanding of impulsivity and impulse control, it is thus necessary to consider the links between interference control on one hand and decisional and motivational impulsivity on the other hand. In addition to the three interference control components, we therefore also investigated decisional and motivational components of impulsivity: Motivational and decision-making aspects influence the initial selection of goals; these goals are subsequently pursued with the assistance of interference control functions that help maintaining focus in the face of distraction.

## Overview of the Present Study

We used a structural equation modeling approach to investigate the relations between the five behavioral components of impulsivity introduced above, as well as their relation with a traditional behavioral inhibition component reflecting the cancellation or stopping of prepotent or already-initiated responses. We carefully analyzed the tasks that have previously been used to assess impulsivity and interference control and identified a set of behavioral paradigms and measures that, in our view, allow for a precise and conceptually clear interpretation of latent variables in terms of psychological processes. In addition to the relations between latent variables, we also investigated their abilities to explain variability in a set of behavioral criterion measures, as well as in self-report measures of impulsivity.

## Aims and Hypotheses

The present study has the following aims: (1) to establish the existence of three different interference-control factors, and to investigate their interrelations, as well as the relations with decisional and motivational impulsivity; (2) to demonstrate that the Stroop and Flanker tasks both involve stimulus- and response-related interference; (3) to demonstrate that resolving interference during selection between competing responses is dissociable from inhibiting prepotent responses, or withholding or stopping already initiated responses; and (4) to assess the relative contributions of the five components of behavioral impulsivity to explaining variance in self-reported impulsivity.

## Method

We briefly describe the indicator tasks used to assess each latent construct, before turning to the details of our study.

### Stimulus Interference (SI)

As outlined above, we are interested in the effect of stimulus interference proper, ideally measured without contamination by potential effects of distracters on the activation of irrelevant responses. To approach this aim, we used variants of a matching paradigm (DeSchepper & Treisman, 1996; Treisman & Fearnley, 1969; see also Friedman & Miyake, 2004) in which a target stimulus (target) is to be compared to a reference stimulus (probe), and participants' task is to indicate the result of this comparison (i.e., match or nonmatch). In this paradigm, stimuli can be made to vary across dimensions that do not overlap with responses. In such paradigms in which stimulus and response dimensions do not overlap (Kornblum, Hasbroucq, & Osman, 1990), distracting stimuli cannot directly activate irrelevant responses. Stimulus interference can then be assessed by comparing performance in conditions with irrelevant distracters to performance in conditions without such a distracter (see Figure 1).

The Shape Matching task used by Friedman and Miyake (2004) to assess Distracter Interference fulfills this criterion. In this task, participants are required to compare two line drawings of shapes (a probe and a target) and to indicate whether the shapes matched or not. On some trials, a distracter shape is presented in a different color. The difference in performance between distracter and no-distracter trials assesses the ability (or failure) to ignore the dis-

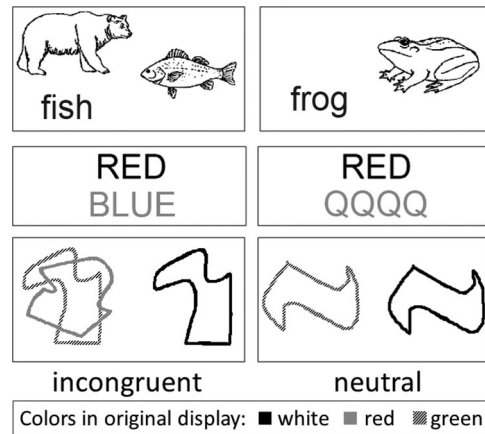

*Figure 1.* Stimulus displays of the stimulus interference tasks. The upper, middle, and lower panels show stimulus displays of the animal matching, the Stroop matching, and the shape matching tasks, respectively (not to scale). In these paradigms, participants assess whether a probe stimulus matches a target stimulus. In neutral match trials (displayed on the right), only the probe and target stimuli are presented on screen, whereas in incongruent match trials (displayed on the left), a distracter stimulus (or stimulus attribute) is additionally presented, allowing two further irrelevant comparisons (viz., distracter with target, and distracter with probe). Both irrelevant comparisons were mismatches in incongruent match trials. See text for additional information for each of the tasks.

tracting stimulus. In this task, stimulus and response dimensions do not overlap. Thus, the perception of the distracter cannot directly activate or trigger an irrelevant response. Instead, effects of the distracter are necessarily mediated by internal representations and cognitive operations on this representation (e.g., the distracter, instead of the target, may accidentally be compared to the probe). This suggests that the Shape Matching task (in particular, the distracter vs. no-distracter contrast) is unlikely to be driven by or contaminated by processes of direct response activation.

In the present study, we used the Shape Matching task as an indicator for the control of stimulus interference, along with two additional variants of this task that share these properties (i.e., an Animal Matching task with line drawings of animals as stimuli, and a Stroop Matching task with colors and color word stimuli; DeSchepper & Treisman, 1996; Dittrich & Stahl, 2013; Goldfarb & Henik, 2006; Treisman & Fearnley, 1969).

### Proactive Interference (PI)

To assess proactive interference (i.e., effects of mental representations previously activated in memory; Keppel & Underwood, 1962), performance in conditions in which a stimulus has previously been relevant is compared with conditions in which it has not been relevant recently. Using paired-associate recall tasks, Friedman and Miyake (2004) found that the latent variable reflecting control of proactive interference was only weakly correlated with control of distracter- or response-interference. This is also consistent with experimental and functional magnetic resonance imaging (fMRI) evidence suggesting that PI can be dissociated from distracter interference (Nee & Jonides, 2009) as well as from response

interference (Bissett, Nee, & Jonides, 2009). However, in Friedman and Miyake's (2004) model, the distinction between the PI variable and the other latent variable (termed Response-Distracter Inhibition [R-DI]) may have been based partly on method variance: Note that the PI factor was based only on recall data, whereas the other factor was based on (mostly speed of) performance in speeded classification tasks. Friedman and Miyake's findings suggest that the two factors captured relevant and distinct concept variance (e.g., PI, but not R-DI, predicted Reading Span recall; R-DI, but not PI, predicted switch costs).<sup>2</sup> Still, the correlation between latent factors may have been artificially reduced by the distinct methods. It would be desirable to show that the separability of PI as a latent factor does not depend on this confounding.

Fortunately, there are well-established tasks for measuring proactive interference that use reaction time (RT) and accuracy as dependent variables (Jonides et al., 2008; Jonides & Nee, 2006; Nee & Jonides, 2009). We used a variant of Sternberg's (1966) paradigm in which participants are asked to report the contents of the current memory set, while ignoring the contents of memory sets from previous trials (Monsell, 1978). In a related paradigm, participants initially memorize two memory sets and are subsequently instructed to ignore one set while reporting on the basis of the other set (J. X. Zhang, Leung, & Johnson, 2003). Performance in both tasks has been shown to be correlated: Nee, Jonides, and Berman (2007) have administered both tasks to the same group of subjects and have reported correlations of  $r = .37$  and  $r = .30$  between tasks, for RT and accuracy interference scores, respectively. Their fMRI data further suggests that both tasks activate overlapping cortical structures. Using these tasks (see Figures 2 and 3), the present research aims at identifying Proactive Interference as a latent variable without relying on recall data.

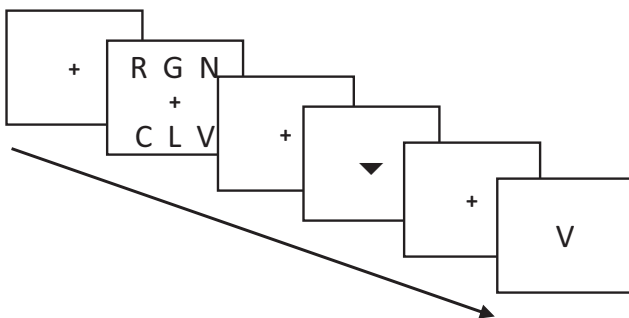

**Figure 2.** Directed forgetting task (lure trial). Each trial started with the display of a fixation cross, after which two triplets of consonants briefly appeared, one above and one below the fixation cross. The consonants disappeared and had to be memorized during a first retention interval. Then, the fixation cross was replaced with an arrow pointing up or down, indicating which of the previously presented triplets of consonants had to be forgotten. After a second retention interval, a probe stimulus was presented that was either neutral (i.e., not presented in the current trial), a target (i.e., from the to-be-remembered triplet), or a lure (from the to-be-forgotten triplet). The difficulty in lure trials (such as the one depicted here) results from the requirement to classify the stimulus as nonmatching, despite there being a relatively strong memory trace from the rehearsal in the first retention interval. In contrast, no such memory trace should be present in neutral trials. The difference in task performance in these two trial types was computed as the relevant contrast.

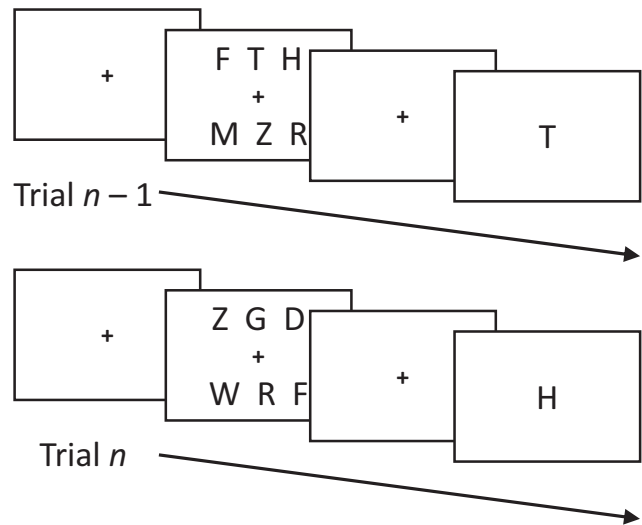

**Figure 3.** Recent probes task (target and lure trials). In each trial, a set of six consonants was presented. After a retention interval, a probe stimulus appeared, and participants had to classify whether this consonant was presented as part of the current trial's stimulus set. Then, the next trial started, following the same procedure. The probe stimulus could either be part of the current trial's set of stimuli (match) or not (nonmatch). Orthogonally, it could have been presented in the directly preceding trial (recent) or not (nonrecent). The difficulty in lure trials (such as Trial  $n$  depicted here) arises from the requirement to give a nonmatch response despite a feeling of familiarity. The difference in task-performance between nonmatch/recent and nonmatch/nonrecent trials was used as a score of proactive interference.

### Response Interference (RI)

To assess interference resulting from the activation of irrelevant responses, we used measures from two well-established paradigms (i.e., priming and task-switching) that have been shown to (almost) exclusively reflect response-related interference (Klauer, Musch, & Eder, 2005). Specifically, we used a priming paradigm in which prime and target stimuli were taken from two different sets (e.g., male or female names, and positive or negative adjectives). Both sets could serve as primes and targets, and participants were to classify the target (which was either a name or an adjective) by pressing one of two buttons (e.g., left = male/negative, right = female/positive). Critical trials are those in which prime and target are from different sets. If, for example, a male first name is presented as a prime, it activates the left response, yielding facilitation if the target is a negative adjective and interference if it is a positive adjective. Importantly, due to the lack of a semantic association between prime and target, this facilitation or interference is purely peripheral or response-based (see Figure 4 for a visual version of this priming task).

A similar task structure is given in task-switching paradigms with bivalent stimuli (i.e., stimuli that can be classified according to both task sets). If, for example, one task-set requires classifica-

<sup>2</sup> It might however be argued that these differential predictions are also due to method variance (i.e., PI may have predicted reading span because both rely on recall data, and R-DI may have predicted switch costs because both relied on measures of the speed of performance).

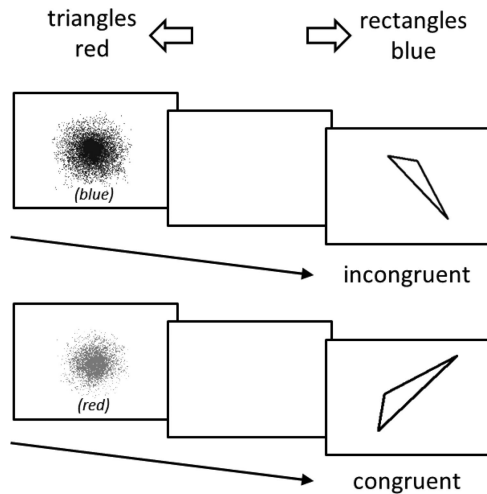

**Figure 4.** Response priming paradigm with colors and geometric shapes. There were two tasks: One required classifying geometric shapes as triangles or rectangles, and the other required classifying color blobs as red or blue, by pressing a left or right button, respectively. In each trial, two stimuli were presented in short succession, and participants were instructed to ignore the first stimulus (the prime) and to classify the second (the target). Responses associated with prime and target can be incongruent (e.g., blue/triangle) or congruent (e.g., red/triangle). All combinations of prime and target categories appeared with equal probability, and the relevant task was indicated by the target stimulus. Note that the response sets of both tasks were overlapping, but the stimulus sets were not. Hence, prime-target congruency effects should be indicative of response-related congruency effects.

tion of geometrical shapes (e.g., triangle vs. circle), and the other task-set requires classification according to color (e.g., blue vs. red), bivalent stimuli such as a red triangle or a blue circle can be processed according to both task-sets. In a given trial, only one task-set is relevant; nevertheless, the response implied by the irrelevant task-set is often also activated involuntarily, leading to facilitation in congruent and interference in incongruent trials. This response-compatibility effect in task-switching paradigms is largely due to activation of responses codes stored in long-term memory (Kessler & Meiran, 2010; Kiesel et al., 2010; Meiran & Kessler, 2008).

We assessed RI using both the priming paradigm and the task-switching paradigm. Each paradigm was administered in two variants with different stimulus materials.

### Information Sampling (IS)

Impulsivity in the sense of lack of reflection was assessed by measuring participants' response criterion (liberal or conservative). Because information sampling takes time, a higher (more conservative) criterion leads to slower responses. As a consequence, information sampling is associated with a focus on accuracy at the expense of speed. To assess the amount of information sampled before a decision is reached, we selected a theory-driven measure of information sampling and decision criterion based on the diffusion model (Ratcliff, 1978). Participants' decision criterion (i.e., the amount of information that is required before a decision is made) was estimated from two simple discrimination

tasks (brightness discrimination and lexical decision). The data from these tasks were used to estimate the diffusion model parameter  $a$ , which is an indicator of the separation between the decision boundaries: Smaller values of parameter  $a$  indicate that decisions are made quickly, without sampling much information; larger values of parameter  $a$  indicate that decisions are based on a more thorough information sampling. This parameter has been validated to reflect manipulations of focus on speed versus accuracy (e.g., Voss, Rothermund, & Voss, 2004).

### Delay Discounting (DD)

In a delay discounting paradigm, participants are asked to indicate whether they prefer to receive a small amount of (real or hypothetical) money (e.g.,  $r = \$150$ ) immediately over receiving a larger reward of money (e.g.,  $\$200$ ) in a delay of  $d$  days (months, years). The amount  $r$  is varied for each level of delay  $d$ , yielding an estimate of how much the value of the immediate reward can be reduced for a given delay while being equally attractive as the delayed award. We administered two variants of this delay discounting task (Du, Green, & Myerson, 2002). For each task separately, we computed the area under the delay curve (AUC) as a standard measure as the dependent variable (Myerson, Green, & Warusawitharana, 2001).

### Additional Measures

Beyond establishing the separability of latent variables in a structural equation modeling (SEM) approach, we also aimed to investigate the ability of these variables to account for variance in several criterion measures. Specifically, we included the Antisaccade, Stop-Signal, and Go/No-Go tasks as measures of traditional behavioral inhibition (see Table 1), as well as the classical Stroop and Flanker inference paradigms (among others). We also assessed general cognitive abilities, using working memory, processing speed, and intelligence measures.

Additionally, we included a set of established self-report measures of impulsivity. As impulsivity is one of the oldest constructs in differential psychology, several self-report measures, often capturing multiple facets of the construct, have been developed, and their scores have been used to predict a wide variety of behaviors (for recent reviews, see Cyders & Coskunpinar, 2011; Kirby & Finch, 2010). However, relations with laboratory-based interference tasks tended to be weak or altogether nonexistent (Cyders & Coskunpinar, 2011; Reynolds, Ortengren, Richards, & Dewit, 2006; Reynolds, Penfold, & Patak, 2008).

We were interested in the contributions of the five components to performance in the above-mentioned measures. First, as discussed above, we predicted that both stimulus- and response-related interference would contribute to both the Stroop and Flanker tasks. Second, because action control is probably not a unitary construct, we expected different forms of response interference to be largely uncorrelated. Furthermore, we expect DD to predict self-reported ability to delay rewards.

### Analyzing Reaction Time and Accuracy

We combined RT and accuracy measures whenever possible. The choice between RT and accuracy measures is often arbitrary:

Performance in a given task is fully characterized only by a combination of these measures, and selecting one while omitting the other can be problematic if part of the variance of interest is in the omitted measure. This is especially so if the proportion of systematic variability that is omitted varies across participants (e.g., due to interindividual variability in speed–accuracy settings). One way of dealing with this problem would be to use mathematical models such as the diffusion model (Ratcliff, 1978) to jointly account for both RT and accuracy of performance. We chose not to do so, mainly for pragmatic reasons, as the use of diffusion modeling requires a large number of data points (i.e., trials) in each task, as well as a substantial error rate, and estimates are often not reliable when either is too small. Instead, we combined RT and accuracy data in a more straightforward manner: For each relevant contrast, we computed the mean of the standardized RT and accuracy measures as indicator variables for the structural equation model.

## Participants

In total,  $N = 198$  adults (130 women; 18–48 years of age) from the department's participant pool (consisting mostly of University of Freiburg students with different majors) volunteered in exchange for monetary compensation.

## General Procedure

The study consisted of three sessions of approximately 2–2.5 hr each, with pauses about every 30 min. After informed consent was obtained, participants were asked to complete the set of self-report measures at home in between Sessions 1 and 2. As part of a larger research project, they were also asked to have a sample of their blood taken for genetic analyses at the University of Freiburg Medical Center between Sessions 1 and 2. A subset of participants was furthermore asked to participate in a related fMRI study subsequent to participation.

In the first session, the order of tasks was as follows: Directed Forgetting 2, Counting Span, Response Priming (Number–Letter), Delay Discounting 1, Stroop Matching, Color–Shape Task Switching, Shape Matching, and Lexical Decision. In the second session, the order of tasks was as follows: Directed Forgetting (Animal), Response Priming (Color–Shape), Delay Discounting 2, Animal Matching, Brightness Discrimination, Recent Probes, and Number–Letter Task Switching. In the third session, the order of tasks was as follows: Directed Forgetting 1, Simon, Stop-Signal, Vocabulary (*Mehrfachwahl-Wortschatz-Intelligenztest* [MWT-B]; Lehrl, 2005), Auditory Go/No-Go, Flanker, N-Back, Speed (Identical Pictures), Stroop, Visual Go/No-Go, Raven matrices (Advanced Progressive Matrices [APM]; Raven, Raven, & Court, 2003), and Antisaccade.

## Materials and Procedure

The majority of the paradigms described below were computerized tasks requiring the classification of stimuli by pressing one of two response keys using the right or left index finger. Instructions equally stressed speed and accuracy of responding. Unless specified otherwise, trial-wise error feedback was given, and a summary of task performance (i.e., mean RT and accuracy) was

given after each block. For each task, the same pseudorandom trial sequence was administered for all participants as we were interested in the assessment of individual differences. The sequence was generated in advance, balancing trial dimensions as far as possible, including the specific affordances in the respective tasks, response key, presentation location, individual stimulus exemplars, and first-order transitions.

**Stimulus interference (SI).** Stimulus interference was measured using the Shape Matching, Stroop Matching, and Animal Matching tasks. They are illustrated in Figure 1.

**Shape matching.** This task was adapted from Friedman and Miyake (2004; see also DeSchepper & Treisman, 1996). In each trial, the stimulus display typically comprised three abstract geometric shapes—a probe, a target, and a distracter (which was absent in the neutral condition). They were selected from a set of 10 shapes used by DeSchepper and Treisman (1996). In each trial, a probe shape was presented on the right side of the black screen in white color (RGB = 255, 255, 255). On the left side of the screen, one or two shapes were presented: The target shape in green color (RGB = 94, 224, 76) was presented alone (neutral condition) or was superimposed on the distracter shape in red (RGB = 224, 76, 76). Jittering the spatial coordinates of target and distracter guaranteed that the distracter was always visible, even if target and distracter had identical shapes. Participants had to classify whether the probe and the target had identical shapes (i.e., matched) or not by pressing the right or the left key, respectively. In case of an error the word “*Fehler!*” (German for “error!”) appeared below the stimuli for 300 ms. At the end of a trial, all shapes were masked with two grids for 400 ms that were displayed where the shapes had previously appeared. There was a blank intertrial interval for 500 ms. In total, participants first completed a practice block (24 trials); then, they completed eight test blocks of 72 (plus four warm-up) trials each. Interference in this task could arise from accidentally comparing the probe with the distracter or the distracter with the target; these irrelevant comparisons could yield *match* or *mismatch* results that might be congruent or incongruent with the relevant comparison. A combination of matching (match, mismatch) and congruency levels (congruent, incongruent, neutral) results in seven different stimulus conditions, with the relevant and both irrelevant comparisons yielding either match or mismatch results. The Shape Matching scores were computed as the difference in task performance between the incongruent and neutral match conditions (i.e., in both conditions, there was a match between probe and target shape; in the interference condition, the distracter shape mismatched both the probe and the target; in the neutral condition, no distracter was presented, thus no interference could arise; there were 96 trials in each condition).

**Stroop matching.** This task was structurally similar to the Shape Matching task but used colors and color words as stimuli. Two strings of capital letters were presented next to each other in the center of a black screen (the probe on the left and the target on the right). The probe always denoted one of four color names (the German words for “RED,” “YELLOW,” “GREEN,” and “BLUE”) and was presented in a neutral light gray (RGB = 220, 220, 220). The target was always presented in one of these four colors, that is, red (RGB = 224, 76, 76), yellow (RGB = 228, 224, 76), green (RGB = 94, 224, 76), and blue (RGB = 76, 146, 224), respectively. Colors were specified to approximate equal luminance



of all presented stimuli. Target color could match or mismatch the semantic meaning of the probe stimulus. Participants were to indicate whether the semantic meaning of the probe matched the color of the target or not by pressing the right and the left response key, respectively. In case of an error, a gray "X" (RGB = 220, 220, 220) was presented beneath the stimuli for 300 ms. The screen was then cleared and remained blank for an intertrial interval of 400 ms. Participants started with two practice blocks, the first comprising 24 neutral trials, the second comprising 24 trials of all types. Then, they completed eight consecutive test blocks of 72 (plus four warm-up) trials each, with an equal number of match and nonmatch trials. The target stimulus could either be a meaningless consonant string ("QQQQ"; neutral stimulus) or it could denote the name of one of the four colors—target meaning either matched (congruent stimulus) or mismatched (incongruent stimulus) target color. Interference could emerge when participants compared the wrong stimulus features (i.e., by either comparing the semantic meaning of the probe with the semantic meaning of the target, or by comparing the semantic meaning of the target with its color; both are examples for matching on irrelevant dimensions). A combination of matching and congruency levels results in seven different stimulus conditions, with the relevant and both irrelevant comparisons yielding either *match* or *mismatch* results. The Stroop Matching score was computed as the difference in task performance between the incongruent and neutral match conditions (i.e., in both conditions, there was a match between probe meaning and target color; in the interference condition, target meaning mismatched both probe meaning and target color; in the neutral condition, a meaningless letter string was presented as the target, thus no interference could arise; there were 96 trials in each condition).

**Animal matching.** This task was very similar to the other two stimulus interference tasks, except that it used well-known animals as stimuli, with names of one syllable length (the German equivalents for bear, fish, frog, fox, hen, deer, dog, cow, mouse, horse, sheep, and pig) presented either as a simple line drawing or by their name spelled out as a word (in both cases, stimuli were presented in white on a black background). The display typically consisted of three stimuli, one stimulus on the right (i.e., the probe) and two stimuli on the left side of the screen (i.e., target and distracter, the latter being absent in neutral trials). Both could either appear as the upper or as the lower stimulus, and their role as target or distracter was determined by their mode of presentation: When the probe was presented as a drawing, the target was a word (and the distracter a drawing) and vice versa. Participants had to classify whether probe and target denoted the same animal (match) or not (mismatch) by pressing the right or left response key, respectively. In case of an error a red "X" (RGB = 255, 100, 100) was displayed below the stimuli for 300 ms. The intertrial interval was 500 ms in total, starting with a blank screen for 100 ms, after which a fixation cross was displayed in the center of the screen. Participants first performed a practice block (24 trials) that comprised all trial types. Eight blocks followed with 72 (plus two warm-up) trials each. As in the two tasks above, interference could result from irrelevant comparisons (i.e., by comparing distracter and probe, or by comparing distracter and target), and seven trial conditions resulted from a combination of the matching and congruency levels. The Animal Matching score was computed as the difference in task performance between the incongruent and neu-

tral match conditions (i.e., in both conditions, there was a match between probe and target; in the interference condition, the target mismatched both probe and distracter; in the neutral condition, a distracter was not present, thus no interference could arise; there were 96 trials in each condition).

**Proactive interference (PI).** Proactive interference was measured using two variants of the Directed Forgetting task as well as the Recent Probes task. They are illustrated in Figures 2 and 3.

**Recent probes.** In this paradigm (see Figure 3; Jonides & Nee, 2006; Nee & Jonides, 2009), each trial started with a fixation cross in the center of the screen (1,500 ms). Subsequently, a memory set of six different letters was presented, a row of three letters above the fixation cross and a row of three letters below the fixation cross (2,000 ms). Stimuli were drawn from the set of 20 consonants and were presented in black color on a light gray screen (RGB = 220, 220, 220). Then the letters disappeared and only the fixation cross remained on screen for a retention interval (3,000 ms), after which the fixation cross was replaced with a probe letter. Participants had to indicate whether the probe letter was part of the previously presented set of six letters or not by pressing the right or left response key, respectively. In case of an error, a red exclamation mark ("!"); (RGB = 255, 0, 0) appeared below the probe stimulus for 500 ms. When a response was given, the screen was cleaned and the next trial started. In total, there were five blocks of 28 trials each. We manipulated orthogonally whether the probe letter was part of the memory set (match vs. nonmatch), and whether the probe letter was part of the memory set on the directly preceding trial (recent vs. nonrecent). In nonrecent trials, the probe letter had not been presented for (at least) the last consecutive three trials. The Recent Probes score was computed as the difference in task performance between recent and nonrecent nonmatch trials on the basis of 35 trials each. The first condition requires the participant to inhibit a formerly valid but now irrelevant response trace in order to give the correct ("nonmatch") response, whereas there is no recent irrelevant trace in the latter condition.

**Directed Forgetting 1.** In this variant of the Directed Forgetting paradigm (see Figure 2; Nee, Jonides, & Berman, 2007), trials started with a fixation cross (1,000 ms), after which two triples of consonants (i.e., the *memory* and *forget* sets) were presented above and below the fixation cross and had to be memorized. They were drawn from a set of 20 consonants without replacement. All stimuli were presented in black font on a light gray background (RGB = 220, 220, 220). After an additional 2,000 ms, the letters were removed, and a retention interval of 3,000 ms started. After that, an arrow was presented in the center of the screen (1,000 ms) as a forget cue, either pointing up or down, thereby indicating which of the formerly presented triples was the *forget* set. After a second retention interval (1,000 ms), one probe letter was presented in the center of the screen. All letters were presented in uppercase in this variant of the paradigm. Participants were asked to indicate whether the probe letter was part of the memory set (i.e., part of the initial display of letters that was *not* to be forgotten) or not by pressing the right or left key, respectively. In case of an error, a red exclamation mark (RGB = 255, 0, 0) was shown below the probe stimulus for 500 ms. The intertrial interval was 500 ms. Participants completed five blocks of 28 trials each. In total, there were 70 match trials, 35 forget trials and 35 neutral trials. The difference in performance between forget and neutral trials served as the dependent variable.

**Directed Forgetting 2.** In this variant of the Directed Forgetting paradigm (J. X. Zhang et al., 2003), all trials started with a fixation cross (1,000 ms). Then two sets of three upper-case letters (i.e., the *memory* and *forget* sets) were presented (one on the left and one on the right; position of sets changed across trials). They were drawn from a set of 20 consonants without replacement. All stimuli were presented in black font on a light gray background (RGB = 220, 220, 220). Participants were asked to memorize all presented letters. After 2,000 ms, the letters were removed and a retention interval of 3,000 ms began. Then, the *forget* set was presented in the center of the screen (1,000 ms), and participants were asked to forget these letters (but to retain those in the *memory* set). After a second retention interval (1,000 ms), a probe letter in lower-case font was presented in the center of the screen. Participants then had to classify whether the presented letter (irrespective of capitalization) was part of the memory set (i.e., part of the initial display but not part of the forget set) or not by pressing the right or left key, respectively. In case of an error, a red exclamation mark (“!”; RGB = 255, 0, 0) appeared below the probe stimulus for 500 ms. There was a 500-ms blank intertrial interval. In total, participants completed five blocks with 28 trials each. In total, there were 70 trials in which the probe matched the memory set (match trials). In 35 forget trials, the probe was part of the forget set, and a nonmatch response had to be given, which required inhibiting a recent but irrelevant memory trace. In 35 neutral trials, the probe letter was novel and had not appeared for at least the last consecutive three trials. The dependent variable was the contrast between forget trials and neutral trials.

**Response interference (RI).** Response interference was measured using a response priming paradigm as well as the response-congruency contrast computed from the Number–Letter and Color–Shape task-switching paradigms. The response priming paradigm is illustrated in Figure 4.

**Response priming.** We used two versions of the Response Priming paradigm reported by Klauer et al. (2005) that were identical with the one exception that they used different stimulus materials. In the number–letter version, there were four odd numbers (3, 5, 7, 9) and four even numbers (2, 4, 6, 8), and there were four consonants (G, K, M, R) and four vowels (A, E, I, U); participants had to classify digits as odd or even, and letters as consonant or vowel; responses were given by pressing the left or right response key, respectively. In the color–shape version, there were four different rectangles and four different triangles, and there were four blobs in different blue color tones and four blobs in different red color tones; participants had to classify shapes as triangle or rectangle, and colors as red or blue; responses were again given by pressing the left or right response key, respectively. To facilitate fixation, all stimuli were presented in a black frame presented in the center of a light gray screen (RGB = 220, 220, 220). Each trial started with a *prime* display (60 ms), followed by a blank interval (10 ms), and the *target* display (until response). Participants were asked to respond during a response window of 140 ms. The onset of the response window was originally set at 500 ms after prime onset but was subsequently adjusted after each block, depending on task performance (see Klauer et al., 2005, for details). To indicate the response window, the stimulus color changed from black to yellow (RGB = 255, 255, 0) in the number–letter version, whereas the frame changed from black to yellow in the color–shape version. If the participant managed to

give the response in the specified response window, stimulus or frame color briefly changed to white (300 ms). Participants were asked to classify only the target stimulus and to ignore the prime stimulus. However, they did not know in advance which task had to be performed in each trial, as the nature of the task was only indicated by the onset of the target stimulus that also served as a task cue. Participants completed five blocks of 50 trials each to familiarize themselves with the primary task affordance as well as with the requirement to deliver responses within the response window. Task performance in these blocks was also used to adjust the onset of the response window. Subsequently, participants completed eight blocks of 48 (plus two warm-up) trials each. The dependent variable was computed on the basis of a subset of trials in which prime and target stimuli were either associated with the same (congruent) or with different response keys (incongruent). In order to remove possible semantic priming effects (see Klauer et al., 2005, for details), we only considered trials in which prime and target belonged to different task-sets (and, hence, stimulus-sets were nonoverlapping). There were 96 trials of each type. As pure response-priming effects tend to be unreliable and small in magnitude, estimates of the effect of both versions of the paradigm were standardized and averaged into a joint score of response priming.

**Number–letter task-switching.** A task-switching paradigm was used, highly similar to that introduced by Rogers and Monsell (1995). In each trial, a digit–letter pair was presented. Digits were either drawn from a set of four odd (3, 5, 7, 9) or four even numbers (2, 4, 6, 8); letters were either drawn from a set of four consonants (G, K, M, R) or four vowels (A, E, I, U). They were presented in black on a light gray screen (RGB = 220, 220, 220). All stimuli were presented in a 2 × 2 grid, and the spatial position served as a task cue. Stimuli were presented in a clockwise fashion, yielding an AABB task sequence with predictable task-switches on every second trial. With an intertrial interval of 400 ms, task-set preparation should be largely completed by that time. When the stimulus pair was presented in one of the upper fields, the number was relevant and had to be classified as odd or even; when it appeared in one of the lower fields, the letter was relevant and had to be classified as consonant or vowel, by pressing the left or right response key, respectively. In case of an error, a red “X” (RGB = 255, 0, 0) was presented below the imperative stimulus for 300 ms. Participants first completed two task-pure blocks of number classifications (44 trials) and of letter classifications (44 trials), then a mixed practice block comprising both tasks thus requiring task switches (24 trials). Two mixed main blocks of 128 (plus eight warm-up) trials each followed. The affordance to switch between tasks and the response compatibility of the component stimuli were varied orthogonally. In response-congruent trials, the relevant and irrelevant features are associated with the same response; in response-incongruent trials, they are associated with different responses. Interference arises if the irrelevant feature involuntarily activates its associated response. The Number–Letter score was computed as the contrast between response-incongruent and response-congruent trials (128 each), collapsed across task-switch and task-repetition trials.

**Color–shape task-switching.** In a second task-switching paradigm, geometric shapes were used as stimuli. Shapes were either triangles, circles, or squares, presented in small (2 cm) or large size (4 cm), and presented in blue (RGB = 0, 0, 255) or in red color

(RGB = 255, 0, 0). All stimuli were presented in the center of a light gray screen (RGB = 220, 220, 220). As a task cue, the shape could be either empty or filled: Filled shapes had to be classified according to their size (small or large), whereas empty shapes had to be classified according to their color (red or blue), by pressing the left or the right response key, respectively. In case of an error, a gray "X" was presented below the imperative stimulus for 300 ms. In a first block, size classification was practiced (44 trials), followed by a practice block for color classifications (44 trials), and a mixed-task practice block (24 trials). Data were analyzed from two subsequent mixed-task blocks with 128 (plus eight warm-up) trials each. In contrast to the Number–Letter paradigm, the task was not predictable, and preparation occurred after stimulus onset. The affordance to switch between tasks and the response compatibility of the component stimuli were again varied orthogonally. The Color–Shape score was computed as the contrast between response-incongruent trials (i.e., trials in which size and color were associated with different responses) and response-congruent trials (i.e., trials in which both stimulus features were associated with the same response key; there were 128 trials of each type), collapsed across task-switch and task-repetition trials.

#### Information sampling (IS).

**Brightness discrimination.** Each trial started with a fixation cross presented in the center of a light gray screen (RGB = 220, 220, 220) for 500 ms. Then, a square pattern (200 × 200 px) of black and white pixels was presented. Each pixel's color was randomly determined with the restriction that there were 47%, 49%, 51%, or 53% white pixels in the pattern. Participants were asked to classify whether the presented pattern comprised more black pixels or more white pixels by pressing the left and the right response button, respectively. In total, participants completed a training block with 40 trials and a test block with 200 trials, 50 of each ratio of black and white pixels. In case of an error, "FEHLER" (German for "ERROR") appeared below the stimulus in black color until the correct response was given. Data were analyzed with Ratcliff's (1978) diffusion model which assumes that a decision process is driven by incoming stimulus information that continuously contributes to the evidence of a left or a right response, respectively. Once the decision process passes one of the response criteria associated with the left or right response, the according response is elicited. The diffusion model allows estimating several parameters of this decision process, including the drift rate (the mean slope of the decision process, reflecting efficiency of information sampling) and the distance between response criteria (reflecting response caution). All diffusion model parameters were estimated with the program *fast-dm* (Voss & Voss, 2007, 2008). Drift rates were allowed to vary as a function of the ratio of black and white pixels; all other parameters were fixed across stimulus types. The estimate for response caution was taken as the score for this paradigm.

**Lexical decision.** Stimuli were frequent nouns (frequency range = 100–900 per million;  $M = 260$ ), rare nouns (frequency range = 1–4 per million;  $M = 1.9$ ), pseudo words ("pronounceable" nonwords; i.e., German nouns with low to moderate frequency for which all vowels were replaced randomly by other vowels), and nonwords (unpronounceable random letter strings; e.g., "hwaajhv"). Words were taken from the CELEX lexical database (Baayen, Piepenbrock, & Gulikers, 1995). Groups of stimuli were matched for word length (4–8 letters;  $M = 6$  letters).

All stimuli were presented in a random order without replacement. On each trial, after a fixation cross (500 ms), a stimulus appeared in the center of the screen (black on light gray; RGB = 220, 220, 220). Participants were asked to classify the presented stimulus as either a nonword or a word by pressing the left or right response button, respectively. There was only one block comprising 200 (plus four warm-up) trials in total (50 for each of the stimulus types). Data were analyzed with the diffusion model as described in the previous task; specifically, drift rates were allowed to vary across trial types. The estimate of response caution served as the score for the current study.

#### Delay discounting (DD).

**Delay Discounting 1.** In this classical variant of the delay discounting paradigm (Du et al., 2002; Lane, Cherek, Pietras, & Tcheremissine, 2003; Mitchell, 1999), participants were presented with seven series of decision tasks. In each trial, participants chose between the hypothetical offer of receiving 200 Euros at a delayed time, or of receiving a somewhat smaller amount immediately. The seven time intervals specified were, in the order of presentation, 1, 3, and 9 months, and 2, 5, 10, and 20 years. For each of the time intervals, six successive trials were used to approximate the amount of money for an immediate reward that was equally attractive as the delayed amount of 200 Euros. Specifically, the offer on the first trial was to receive 150 Euros immediately instead of 200 Euros in 1 month. If participants rejected the immediate offer, the offer was increased by half the difference between the actual and the last offer (here 200 Euros); whereas if they accepted, it was decreased by half the difference to the last offer. Relevant details of both alternatives were displayed on screen, the lower amount of money on the left and the 200 Euros on the right side. Accordingly, participants accepted the lower amount of money by pressing the left key and they rejected it by pressing the right key. They could restart the run for the present time interval pressing "K" on the keyboard. The so derived values represent subjective equivalents of the delayed reward of 200 Euros. If the immediate values are plotted as a function of delay, the area under the curve (AUC) can be computed as a measure of delay discounting, with low scores reflecting strong discounting.

**Delay Discounting 2.** The second version of the discounting paradigm was a newly developed "loan" variant. Specifically, participants were asked if they preferred to (hypothetically) receive a certain amount of money immediately when they had to (hypothetically) return 10,000 Euros at a specified delay. The specified time intervals were 1, 2, 5, 10, 20 years. The offer to receive immediately was presented on the left and the amount that needed to be returned on the right of the screen. Participants accepted the offer by pressing the left key and rejected it by pressing the right key, and they could restart a run by pressing "K." The preferred amount of money to be received immediately was approximated in the same way as described in the classical variant of the discounting paradigm across a run of five trials. The starting value of the amount of money directly offered was 8,750 Euros. Again, the assigned equivalents were plotted as a function of time, and the area under the curve (AUC) was computed as the score for this task.

**Working memory, processing speed, and intelligence.** In addition to the components of interference control, we assessed general cognitive ability using working memory, processing speed, and intelligence measures (fluid and crystallized). Working mem-

ory (WM) was assessed using a version of the Counting Span task (we computed the all-or-nothing-load score; see Conway et al., 2005). Processing speed was measured using the Identical Pictures task (Ekstrom, French, & Harman, 1976). Fluid intelligence was assessed using the Raven matrices (APM; Raven et al., 2003); crystallized intelligence was assessed using a measure of vocabulary (MWT-B; Lehrl, 2005), respectively.

**Working memory capacity (Counting Span).** In the present version of this working memory capacity (WMC) measure (Conway et al., 2005), 14 small geometric shapes (each 1 cm in diameter) were presented in each trial randomly spread across an area of about 15 cm width and 10 cm height in the center of the light gray screen (RGB = 220, 220, 220). There was a variable number of dark blue circles (RGB = 0, 0, 150), dark blue rectangles (RGB = 0, 0, 150) and light blue circles (RGB = 85, 85, 255). All pictures shown were generated in advance so that the presentation format was identical for all participants. The task was to count the number of dark blue circles in each trial and to enter the number on the keyboard. Directly upon pressing the enter key, the next trial with geometric shapes was presented. After a variable nonpredictable sequence of 2–5 counting trials, three question marks appeared in the center of the screen. In these span trials, participants had to enter all results of their previous counts since the last span trial in the order of presentation. Participants completed a training block of nine counting trials in total, and a test block comprising 28 counting trials and eight span trials. The proportion of trials in which a completely correct sequence was entered served as an estimate of WMC.

**Speed (Identical Pictures).** Stimuli were simple line drawings in blank ink on a white ground and were composed of simple geometric forms. Some of these pictures resembled objects from everyday life (a mug, a door, etc.). In each trial, six stimuli were shown in a row, with the first slightly disposed to the left and serving as a probe. Participants had to identify which of the set of five remaining stimuli was identical to the probe by entering a corresponding number on the keyboard. Participants were instructed that they should complete as many trials in the given time of 90 s as possible without committing errors. None of the participants completed the set of 60 pictures in the given time. The number of correctly matched pictures was used as the speed score.

**Fluid intelligence (Gf; Raven).** We used a computerized adaptation of the Advanced Progressive Matrices (APM, Set 2; Bulheller & Häcker, 1998; Raven et al., 2003). As in the paper version of this instrument, the matrix with the pictographs was shown in the upper half of the screen. In the lower part of the screen were the eight response options, and participants entered the corresponding number on the keyboard, after which the next trial started. Participants were instructed to solve as many trials correctly as they could within 5 min. The 36 items were presented in ascending difficulty. The number of correctly solved items served as the fluid intelligence score.

**Crystallized intelligence (Gc; Vocabulary).** We used a computerized adaptation of an established German vocabulary test (i.e., the MWT-B; Lehrl, 2005). On each trial, participants were presented with five words in the center of the screen. Only one of them was a correctly spelled German word, the others were pseudo-words not used in the German language. The task was to identify the correct word by pressing the corresponding number on the keyboard, upon which the next trial started. There were 37

items presented in ascending difficulty, and participants were instructed to solve as many items correctly as they could within 5 min. The number of correctly solved items served as the crystallized intelligence score.

#### Classical interference paradigms.

**Stroop.** In this variant of the Stroop paradigm, one word was presented in the center of the black screen in each trial, either in red (RGB = 224, 76, 76), yellow (RGB = 228, 224, 76), green (RGB = 94, 224, 76), or blue (RGB = 76, 146, 224). Participants were asked to identify the font color and respond by key press (i.e., press the left button if the font color was red or yellow; press the right button if it was blue or green). In the test blocks, the words always denoted one of these four colors (i.e., the German words for “RED,” “YELLOW,” “GREEN,” or “BLUE”). Word meaning could match font color (identical condition) or mismatch (i.e., refer to a response-congruent or response-incongruent color). In case of an error, “Fehler!” (German for “Error!”) was presented below the stimulus for 300 ms in light gray ink (RGB = 220, 220, 220). The intertrial time was 400 ms. Participants started with a practice block (24 trials) in which the presented stimulus was a neutral letter string (“QQQQ”), after which they completed a mixed practice block (24 trials) with identical, congruent and incongruent trials. Data were analyzed from four test blocks comprising 96 (plus four warm-up) trials each. The Stroop interference effect was computed as the difference between the incongruent and identical conditions (128 trials each).

**Flanker.** In a trial of our Flanker paradigm (Eriksen & Eriksen, 1974), seven letters were presented in white ink (RGB = 255, 255, 255) on a black screen. The stimulus at the center was the target that had to be classified, and there were three identical letters drawn from the same pool as the target (i.e., “H,” “T,” “F,” “L”) on the left and on the right side of the target presented as distracters. The task was to press the left button when the target was an “H” or a “T,” and to press the right button if the target was an “F” or an “L.” The distracter letter could match (identical condition) or mismatch the target (i.e., represent a response-congruent or response-incongruent letter). In case of an error, “Fehler!” (German for “Error!”) was presented below the letter string for 300 ms. The intertrial interval was 400 ms. Participants started with a training block (24 trials) without flanking distracters, then they completed a training block with flanking distracters (24 trials). There followed four test blocks, each comprising 96 (plus four warm-up) trials. The Flanker interference effect was computed as the difference between the incongruent and identical conditions (128 trials each).

**Stop-Signal task.** In this version of the Stop-Signal task (Lapin & Eriksen, 1966; Logan & Cowan, 1984; for a recent review see Lipszyc & Schachar, 2010), each trial started with a light-gray circle (RGB = 230, 230, 230) presented in the center of a black screen for 500 ms. A light-gray horizontal arrow then appeared in this circle, either pointing to the left or to the right; participants had to press the corresponding response key. In 25% of the 256 trials, the circle changed its color to blue (RGB = 25, 8, 250) shortly after the onset of the arrow, which served as a stop signal. In these trials, participants were instructed to omit a response. The time between onset of arrow and stop signal (i.e., the stop-signal delay [SSD]) was initially set at 220 ms and was subsequently adjusted as a function of the participant’s ability to inhibit the response. When participants managed to omit a response, the SSD was increased by 50 ms; it was decreased (to a minimum of 20 ms)

when participants responded or when a response had been given prior to the onset of the stop signal. The traditional score for this paradigm is the time required to successfully inhibit an ongoing response plan (i.e., the stop-signal reaction time [SSRT]). SSRT was computed in the classical way by subtracting the mean SSD from the median latency of trials without stop signal. However, similar results were obtained when the integration method was employed that actually considers the proportion of successfully inhibited stop trials for each person (e.g., Schachar et al., 2007). Because successful stopping may be strategically enhanced by longer RT on go trials, we computed a combined score as the mean of the standardized SSRT and the RT on go trials.

**Antisaccade.** In the present version of the Antisaccade task (Hallett, 1978; Hutton, 2008; for a recent overview, see Hutton & Ettinger, 2006), each trial started with the presentation of a small black square (14 px × 14 px) in the center of a white screen (RGB = 245, 245, 245) for 370 ms. After the square was removed, a rectangle appeared 75 px above or below the center as an attention cue. After 500 ms, the target stimulus was presented, either in the position of the attention cue or at the opposite position. The target consisted of either one long or two short lines (total length equaled that of the square), and participants were asked to identify how many lines were presented by pressing the left or the response button for one or two lines, respectively. The stimulus remained on screen until a response was given. There were two blocks comprising 108 trials each. In the first pro-saccade block, the target always appeared in the place of the attention cue, and participants were explicitly instructed to direct their attention to the attention cue as soon as it appeared. In the second antisaccade block, the lines always appeared in the position opposite to the attention cue, and participants were explicitly instructed to direct their attention to the opposite position as soon as the attention cue appeared. The Antisaccade score was computed as the difference in task performance between the antisaccade and pro-saccade blocks.

**Go/No-Go task.** In each trial, a white letter was presented in the center of the black screen. Letters were selected from a set of 21 consonants. Stimulus onset was randomly varied in four steps (600, 700, 800, 900 ms). Participants were asked to press the right button as soon as possible when a stimulus appeared on screen (go trials), except when an “X” was presented, in which case they should withhold a response (no-go trials). A training block of 30 trials was followed by a test block comprising 300 trials (89 no-go trials). The proportion of responses in no-go trials (i.e., commission errors) was used as the interference score. Because successful withholding of a response may be strategically facilitated by delaying responses on go trials, we computed a combined score as the mean of the standardized commission error rate and the RT on go trials.

**Self-report measures.** Participants were asked to complete the Barratt Impulsiveness Scale (BIS-11; Barratt & Patton, 1995; Patton et al., 1995); the Sensation-Seeking Scale (SSS V; Beauducel, Strobel, & Brocke, 2003; Zuckerman, 1994); the Urgency, Premeditation, Perseverance, Sensation-Seeking (UPPS) questionnaire (Whiteside & Lynam, 2001; Whiteside, Lynam, Miller, & Reynolds, 2005); the Behavioral Avoidance/Inhibition (BIS-BAS) scale (Carver & White, 1994); Lockwood, Jordan, and Kunda’s (2002) Motivational Scale; Blass’s (1983) Delay-of-Gratification Scale; the Cognitive Failures Questionnaires (CFQ; Broadbent, Cooper, Fitzgerald, & Parkes, 1982); the White Bear Suppression Inventory (WBSI; Wegner &

Zanakis, 1994); and the Symptom Check List (SCL-R; Franke, 1995).

## Data Analysis and Outlier Detection

In a first step, trials were excluded from analyses for which RT was either below 200 ms, more than three interquartile ranges below the first quartile, or more than three interquartile ranges above the third quartile, of an individual’s RT distribution for this task. Percentage of correct responses was computed on the basis of the remaining trials. RT analyses are based only on trials with correct responses. As dependent variables, the mean of the standardized RT and accuracy scores for the relevant contrast were computed. Finally, univariate outliers (i.e., a participant’s score that was more than three interquartile ranges below the first quartile or more than three interquartile ranges above the third quartile of the sample’s distribution for a given task) were replaced with the cutoff values (i.e., three interquartile ranges below the first quartile, or three interquartile ranges above the third quartile, respectively). The resulting variables were distributed approximately normally (see Table 2). We checked for multivariate normality using Mardia’s (1970) kurtosis index, which indicated the existence of outliers. However, when multivariate outliers (i.e., cases with significant Mahalanobis’s  $d^2$  values) were excluded, the pattern of correlations did not change much. Therefore, no observations were excluded from the analyses reported below.

## Model Analyses

A total of  $N = 190$  complete data sets were obtained for confirmatory factor analyses (eight additional participants contributed incomplete data on one or more of the indicator tasks; they were excluded from all analyses). Latent variables were standardized (i.e., fixed to have  $M = 0$  and  $SD = 1$ ). Variables were coded such that greater values reflect greater levels of interference or impulsivity. To reduce the number of free parameters, and to ensure comparable contributions of each indicator variable, we decided to equate the unstandardized factor loadings across the indicator variables of a given factor. Model analyses were computed using AMOS software’s maximum likelihood procedures (Arbuckle, 2006). In some of the SEM regression analyses, there were additional cases of missing data that were treated using the AMOS software’s full information maximum likelihood approach (for a review, see Enders & Bandalos, 2001).<sup>3</sup>

To assess a model’s goodness of fit, multiple fit indices were used (Hu & Bentler, 1998, 1999): the root-mean-square error of approximation (RMSEA) and standardized root-mean-square residual (SRMR). For both RMSEA and SRMR, acceptable fit is typically thought to be indicated by values below .08, with values below .05 indicating good fit. In a simulation study, Hu and Bentler (1999) found that evaluating model fit based on a combination of  $RMSEA < .06$  and  $SRMR < .09$  resulted in the least sum of Type I and Type II error rates, implying that allowing for a modestly higher value of SRMR compared to RMSEA may reduce model selection errors. We thus decided to reject models with  $RMSEA \geq .05$  or  $SRMR \geq .08$ .

<sup>3</sup> The Stroop, Antisaccade, and Go/No-Go scores each had one missing value; the Stop-Signal score had 18 missing values.

Table 2  
Descriptive Statistics for Indicator Variables Used in Model Analyses

Measure	Minimum	Maximum	<i>M</i>	<i>SD</i>	Skew	Kurtosis	Reliability
Stroop matching	-1.15	1.81	-0.05	0.71	1.35	1.33	.84 <sup>a</sup>
Animal matching	-1.21	2.32	-0.03	0.71	1.17	1.53	.79 <sup>a</sup>
Shape matching	-1.35	2.43	-0.01	0.65	0.58	0.65	.69 <sup>a</sup>
Recent probes	-2.02	2.03	0.00	0.72	0.16	0.56	.51 <sup>a</sup>
Directed Forgetting 1	-1.45	2.33	-0.01	0.64	0.91	1.16	.51 <sup>a</sup>
Directed Forgetting 2	-2.17	1.90	-0.01	0.64	0.55	2.04	.60 <sup>a</sup>
Response priming	-1.54	1.90	0.00	0.61	0.51	0.54	.56 <sup>a</sup>
Number-letter	-1.70	2.47	0.00	0.77	0.66	0.52	.67 <sup>a</sup>
Color-shape	-1.61	2.85	0.00	0.80	0.43	-0.11	.63 <sup>a</sup>
Criterion 1	-2.70	-0.57	-1.26	0.41	-0.93	0.66	—
Criterion 2	-2.59	-0.73	-1.30	0.33	-0.82	0.83	—
Delay Discounting 1	-0.84	-0.01	-0.22	0.21	-1.55	1.88	—
Delay Discounting 2	-0.96	-0.49	-0.76	0.15	0.31	-1.23	—

Note. A dash indicates that the reliability estimate could not be computed.

<sup>a</sup> Split-half reliability, Spearman-Brown corrected.

For model comparisons, the  $\chi^2$  statistic and the Akaike information criterion (AIC; Akaike, 1974) were computed. The  $\chi^2$  statistic assesses the deviation of the predicted covariance matrix from the observed covariance matrix. Smaller values (i.e., below the critical value) indicate the lack of substantial deviations. In addition to model fit, AIC takes into account model parsimony (i.e., the number of parameters). When comparing two nested models, the difference in goodness of fit between the models can be evaluated using the  $\chi^2$  distribution to determine whether one model fits significantly better than the other. In contrast to the  $\chi^2$  statistic, AIC can also be used to compare nonnested models. Wherever possible, psychological hypotheses (e.g., about parameters) were tested by comparing the goodness of fit of nested models. An  $\alpha$  level of .05 was used.

Power for model fit and model comparison tests was adequate. For the present set of models with  $df > 60$ , RMSEA was sufficiently sensitive to identify model misfit (i.e., power for a test of close fit  $> .80$ ; MacCallum, Browne, & Sugawara, 1996). Similarly, the present model comparison tests were well able to signal differential fit (i.e., power increases with number of  $df$  and approaches 1 already for  $df = 40$  given the present sample size; MacCallum, Browne, & Cai, 2006). To further assess the influence of sample size on model fit indices and model comparison tests, we computed the corrections recommended by Herzog and Boomsma (2009), but found that the pattern of significant and nonsignificant model comparison tests did not differ from those obtained for the uncorrected values reported below.

## Results and Discussion

Results are reported in three steps. In a first step, relations between latent factors were investigated using SEM analyses. In a second step, we assessed the factors' contributions to explaining variability in several criterion measures (Stroop and Flanker tasks, self-reported impulsivity, general ability). In a third step, we focused on response-related impulsivity and investigated whether it may consist of two separable subcomponents.

Table 2 gives descriptive statistics for the variables used in the model. Reliability was within acceptable ranges. Zero-order correlations (see Appendix A) were generally low ( $r \leq .38$ ), yet

somewhat higher than in previous research (Friedman & Miyake, 2004), suggesting that the tasks used to assess the same factor were more comparable to each other than in previous research.

## Relations Between Latent Factors of Behavioral Impulsivity

The results of model analyses are summarized in Table 3. A five-factor model with correlated factors fared best (model no. 1). It is depicted in Figure 5. In this model, the SI factor was significantly correlated with PI and RI; the PI factor was also significantly correlated with DD, and the RI factor was also significantly correlated with IS. The correlated five-factor model described the covariance structure much better than a null model that assumes independence (i.e., zero covariances; model no. 0). The correlated five-factor model adequately accounted for the data: Both RMSEA and SRMR were clearly below .05 and .08, respectively, indicating a good fit. The nonsignificant  $\chi^2$  statistic confirmed that the covariance matrix predicted by the model did not deviate significantly from the observed covariance matrix.

To test whether this model could be simplified, we tested whether a single-factor unity model could better account for the data (model no. 2); we also created a series of four-factor models by equating the five factors in a pairwise manner (model numbers 3–12). Relative to the correlated five-factor model, goodness-of-fit of all of the simplified models was clearly worse, as indicated by likelihood-ratio test and a comparison of fit statistics (see Table 3). Given that all of the pairwise equality restrictions were rejected, we concluded that the correlated five-factor model represents the best account of the data.

We analyzed the correlated five-factor model further by investigating the correlations between latent factors. In a first step, we tested whether a model with five uncorrelated factors would fit the data (model no. 13); this was not the case, as revealed by a significant  $\chi^2$  statistic (see Table 3). This result further supports the interpretation that there were substantial relations between the latent variables depicted in Figure 5. Next, we computed model comparison tests for a set of nested submodels: In each submodel, one of the correlations between

Table 3  
*Goodness-of-Fit Statistics and Model Comparison Results*

No.	Model	$\chi^2$	<i>df</i>	<i>p</i>	$\chi^2/df$	RMSEA	SRMR	AIC	$\Delta\chi^2$
0	Null model	195.80	78	<.001	2.51	.089		247.81	120.87 <sup>a</sup>
1	Five correlated factors (see Figure 5)	74.93	63	.144	1.19	.032	.061	156.93	
2	Unity (single factor)	135.62	73	<.001	1.86	.067	.086	197.62	60.69 <sup>a</sup>
3	PI = SI	86.47	68	.065	1.27	.034	.067	158.47	11.55 <sup>a</sup>
4	PI = RI	89.22	68	.043	1.31	.041	.069	161.22	14.29 <sup>a</sup>
5	PI = IS	103.59	68	.004	1.52	.053	.075	175.59	28.66 <sup>a</sup>
6	PI = DD	92.35	68	.026	1.36	.044	.072	164.35	17.42 <sup>a</sup>
7	SI = RI	94.12	68	.020	1.38	.045	.071	166.12	19.19 <sup>a</sup>
8	SI = IS	120.57	68	<.001	1.77	.064	.082	192.57	45.65 <sup>a</sup>
9	SI = DD	122.95	68	<.001	1.81	.065	.085	194.95	48.02 <sup>a</sup>
10	RI = IS	86.59	68	.064	1.27	.038	.068	158.59	11.67 <sup>a</sup>
11	RI = DD	102.67	68	.004	1.51	.052	.077	174.67	27.74 <sup>a</sup>
12	IS = DD	104.00	68	.003	1.53	.053	.074	176.00	29.07 <sup>a</sup>
13	Five uncorrelated factors	112.68	73	.002	1.54	.054	.086	174.68	37.76 <sup>a</sup>
14	<i>r</i> (PI, SI) = 0	86.28	64	.030	1.35	.043	.070	166.28	11.35 <sup>a</sup>
15	<i>r</i> (PI, RI) = 0	76.71	64	.132	1.20	.032	.062	156.71	1.79
16	<i>r</i> (PI, IS) = 0	74.93	64	.165	1.17	.030	.061	154.93	0.00
17	<i>r</i> (PI, DD) = 0	79.51	64	.092	1.24	.036	.064	159.51	4.58 <sup>a</sup>
18	<i>r</i> (SI, RI) = 0	82.51	64	.060	1.29	.039	.068	162.51	7.58 <sup>a</sup>
19	<i>r</i> (SI, IS) = 0	75.00	64	.164	1.17	.030	.061	155.00	0.07
20	<i>r</i> (SI, DD) = 0	74.93	64	.165	1.17	.030	.061	154.93	0.00
21	<i>r</i> (RI, IS) = 0	85.32	64	.039	1.33	.042	.069	165.32	10.39 <sup>a</sup>
22	<i>r</i> (RI, DD) = 0	74.93	64	.165	1.17	.030	.061	154.93	0.00
23	<i>r</i> (IS, DD) = 0	76.78	64	.131	1.20	.033	.062	156.78	1.85
24	Nested-factor model (see Figure 6)	87.39	68	.059	1.28	.039	.071	159.39	
25	BI as additional factor (see Figure 7)	121.29	99	.064	1.23	.034	.063	227.29	

Note. The last column ( $\Delta\chi^2$ ) gives results of a model comparison with Model No. 1. RMSEA = root-mean-square error of approximation; SRMR = standardized root-mean-square residual; AIC = Akaike information criterion; PI = proactive interference; SI = stimulus interference; RI = response interference; IS = information sampling; DD = delay discounting; BI = behavioral inhibition.

<sup>a</sup> Denotes significant reduction in goodness-of-fit.

latent variables was set to zero (i.e., model numbers 14–23 in Table 3). These analyses confirmed the pattern of correlations between the latent factors shown in Figure 5 (i.e., the italicized correlations, but not the correlations in boldface, could be restricted to zero without loss of goodness-of-fit): Constraining the correlations between SI and PI, SI and RI, PI and DD, or RI and IS to zero resulted in a significant reduction of goodness-of-fit. Constraining the remaining correlations to zero did not harm goodness-of-fit; in fact, a model in which all the other correlations between latent factors were constrained to be zero yielded a good fit ( $\chi^2 = 79.11$ ,  $df = 69$ ,  $p = .19$ , RMSEA = .028, SRMR = .064, AIC = 149.11). To summarize, a model with five correlated factors adequately described the empirical covariance structure. Some of the latent variables were significantly correlated, but no two factors could be merged without substantial loss of goodness-of-fit. These results support the proposed factor structure of behavioral impulsivity components. The present findings suggest that Friedman and Miyake (2004) were correct in assuming that Distracter interference (i.e., SI) and Response inhibition (i.e., RI) were separable, despite the lack of support for this interpretation in their data. Our findings also replicate the existence of PI as a separate factor. Extending previous findings, we investigated latent correlations with information sampling and delay discounting. We found two significant correlations: The tendency to set a liberal response criterion was correlated with response interference, and proactive interference was moderately correlated with delay

discounting. In all, our findings support the notion that behavioral impulsivity is a multifaceted construct that involves decisional as well as motivational components.

**A nested-factor approach.** The SEM analysis above used a correlated-factor approach to capture relations between latent variables. In doing so, it relies on the simplifying assumption that each indicator variable is only influenced by a single latent factor; correlations between indicator variables are thus necessarily mediated by correlations between latent factors. There is at least one other way in which relations between latent variables can be modeled: The interrelations between factors might instead stem from the fact that some indicator variables are driven by an underlying general factor but also share some variability associated with the specific affordances in a group of paradigms that might be more adequately modeled by specific factors, so-called group factors (bifactor or nested factor modeling; Holzinger & Swineford, 1937; Reise, Moore, & Haviland, 2010). We used this approach (which is illustrated in Figure 6 and is described in more detail in Appendix B) to investigate the two strong correlations between components identified above, in order to better understand the nature of the large amounts of shared variability they imply. A nested-factor approach also helped evaluate the components' specific contribution to explaining variability in a set of criterion measures: A critical advantage of this approach is that it can be used to yield uncorrelated latent variables. For the subsequent regression analyses, this is an important advantage over the correlated-factor model depicted in Figure 5 because, in that model, there are five correlated predictors, with substantial bivariate correlations, and using

this model for subsequent regression analyses would lead to problems of collinearity.<sup>4</sup>

In Figure 5, it is apparent that the strongest correlations were between the SI and PI, and between RI and IS. Thus, in a nested-factor version of that model, we captured these two strongest correlations by including two additional general factors in which the two pairs of strongly correlated factors were nested. Specifically, the variability shared by SI and PI was modeled by an additional general factor  $SI_g$  (i.e., reflecting a common underlying stimulus-related interference component), and the variability shared by RI and IS was modeled by another general factor  $RI_g$  (i.e., reflecting a common underlying response-related interference component).

The resulting nested-factor model (i.e., model no. 24 in Table 3) is depicted in Figure 6 and yielded an acceptable fit. Although restricting all correlations to zero affected model fit indices, they were still within acceptable ranges (i.e., RMSEA < .05, SRMR < .08; see Table 3). Most importantly, the model does no longer suffer from collinearity problems: Its tolerance values are quite acceptable (i.e., .72 or greater), with variance inflation practically eliminated (i.e., variance inflation factors [VIFs] < 1.4). This model was used in the subsequent regression analyses.<sup>5</sup> The results obtained from these analyses were corroborated by analyses using the original correlated-factor model (see Appendix D).

### Predicting Stroop and Flanker Interference, Self-Reported Impulsivity, and General Ability

Beyond establishing the multifaceted nature of behavioral impulsivity, we were interested in the contribution of the above factors in predicting criterion measures of interference and impulsivity. Table 4 reports descriptive statistics for the criterion measures. In the regression analyses reported below, we used the model depicted in Figure 6. In this model, the  $SI_g$  and  $RI_g$  factors represent the variability of the original SI and RI factors, as well as their shared variability with PI and IS, respectively. The new factors  $PI_r$  and  $IS_r$  reflect only the variance components of the original factors that were not shared with SI and RI, respectively.

To investigate which of the factors explained variance in a criterion measure, we identified paths that significantly contributed to accounting for criterion variability. We examined regression weights (i.e., path coefficients) in a set of SEM models (as illustrated in Figure 6), and determined whether including paths into the model improved goodness of fit (or whether omitting a path from the model harmed fit). First, we obtained regression weight estimates from a model that contained all possible paths. To see whether there were any substantial relations between factors and criterion measures at all, we tested whether dropping all paths harmed model fit. If this was the case (or if there were regression weights significantly different from zero), we computed a final model including those paths that significantly contributed to explaining criterion variability (i.e., paths that, when included, improved model fit). To determine whether the identified paths could fully account for the relations between factors and criterion measures, we then compared the final model with the initial all-paths model; the final model was accepted if its goodness of fit was comparable to that of the all-paths model.

For each analysis, we grouped several criterion measures into a single model with correlated residuals. The resulting standardized regression coefficients are reported in Table 5 (for the Stroop and Flanker tasks, general cognitive ability measures, and age) and Table 6 (self-report

measures). Model fit statistics are reported in Table 7. We first consider the role of behavioral impulsivity components in Stroop and Flanker tasks before turning to self-report measures and general cognitive ability.<sup>6</sup>

**Stroop and Flanker interference.** We hypothesized that both stimulus- and response-related interference control predict both Stroop and Flanker effects. As discussed above, Stroop and Flanker tasks are thought to be similar, in that they both require the ability to control stimulus-related interference as well as the ability to control response-related interference. This was tested in a set of SEM regression analyses with Stroop and Flanker effects on RT and Accuracy as criterion measures. Regression weights are reported in Table 5, with values in boldface indicating that a prediction emerged as significant in model comparison analyses. A comparison of the all-paths and no-paths models indicated the existence of significant predictions (i.e., dropping all paths harmed model fit; see Table 7). Specifically, for the Stroop task,  $SI_g$  predicted both RT and accuracy scores. In addition,  $IS_r$  predicted Stroop accuracy. In case of the Flanker task,  $SI_g$  predicted only the RT score. In addition, Flanker accuracy was predicted by  $RI_g$  (note that including a marginally significant path from  $PI_r$  did not improve goodness-of-fit,  $\Delta\chi^2(1) = 2.33, p = .13$ ). The final model included five paths and was well able to account for the data (see Table 7), demonstrating that the correlations between latent factors and the Stroop and Flanker RT and accuracy scores were fully accounted for by the identified predictions from  $SI_g$ ,  $RI_g$ , and  $IS_r$ .<sup>7</sup>

<sup>4</sup> In the correlated-factor model (see Figure 5), tolerance values (computed from individual factor score estimates) were at .24 or below, leading to unacceptably high variance inflation factors (VIFs; i.e., three out of five VIFs > 13). The potential problem of collinearity increases with the number of predictors as well as the magnitude of their interrelations; thus, if our findings are at all indicative of the true underlying relations between facets of impulsivity, collinearity will likely also appear in future studies using a comparably comprehensive approach.

<sup>5</sup> To control whether the reduced goodness-of-fit resulting from restricting all latent correlations to zero compromised the regression analyses reported below, we also computed a model in which the latent covariances between  $SI_g$  and  $RI_g$ , and between  $PI_r$  and  $DD$ , were not restricted to zero (estimates were .38 and .50, respectively). This model fully accounts for the four significant latent covariances obtained above, and obtained an excellent fit,  $\chi^2(66) = 77.49, p = .158$ , RMSEA = .030, SRMR = .062, AIC = 153.49. Yet, its variance inflation factors (VIFs) were still twice as high as those of the selected model no. 24 (i.e.,  $2 < VIF < 3$ ). Importantly, the same relevant paths were identified in both models, and the result pattern of model comparison tests was identical.

<sup>6</sup> In a final set of analyses, we tested whether the SEM regression results obtained above using the nested-factor model (see model no. 24 in Table 3; also see Figure 6) were replicated in the original model (see model no. 1 in Table 3; also see Figure 5). In these analyses, paths from SI, PI, RI, and IS replaced paths from  $SI_g$ ,  $PI_r$ ,  $RI_g$ , and  $IS_r$ , respectively (with DD unchanged across models); the latent variables were highly correlated across models (i.e., correlations were .97, .66, .89, .87, .98, respectively). The resulting pattern of significant and nonsignificant model comparison tests (see Appendix D) was the same as for the nested-factor model, and both the all-paths and the final models were well able to account for the data. This finding confirms that the conclusions regarding the relevant predictions also hold for the initial correlated-factor model.

<sup>7</sup> We also investigated the combined scores (i.e., means of standardized RT and accuracy scores) for both tasks. Goodness-of-fit statistics are reported in Table 7; although the  $\chi^2$  statistic just reached significance,  $p = .045$ , a RMSEA of .038 indicated that the initial all-paths model yielded an acceptable fit. The paths from stimulus-related interference  $SI_g$  predicting both Stroop and Flanker tasks were significant (i.e., adding them to the model substantially improved goodness of fit,  $\Delta\chi^2(2) = 12.38, p = .002$ ; note that including the path from DD predicting the Flanker score did not yield a better fit,  $\Delta\chi^2(1) = 3.58, p = .06$ ). The final model adequately accounted for the data (i.e., its fit was similar to that of the all-paths model; see Table 7).



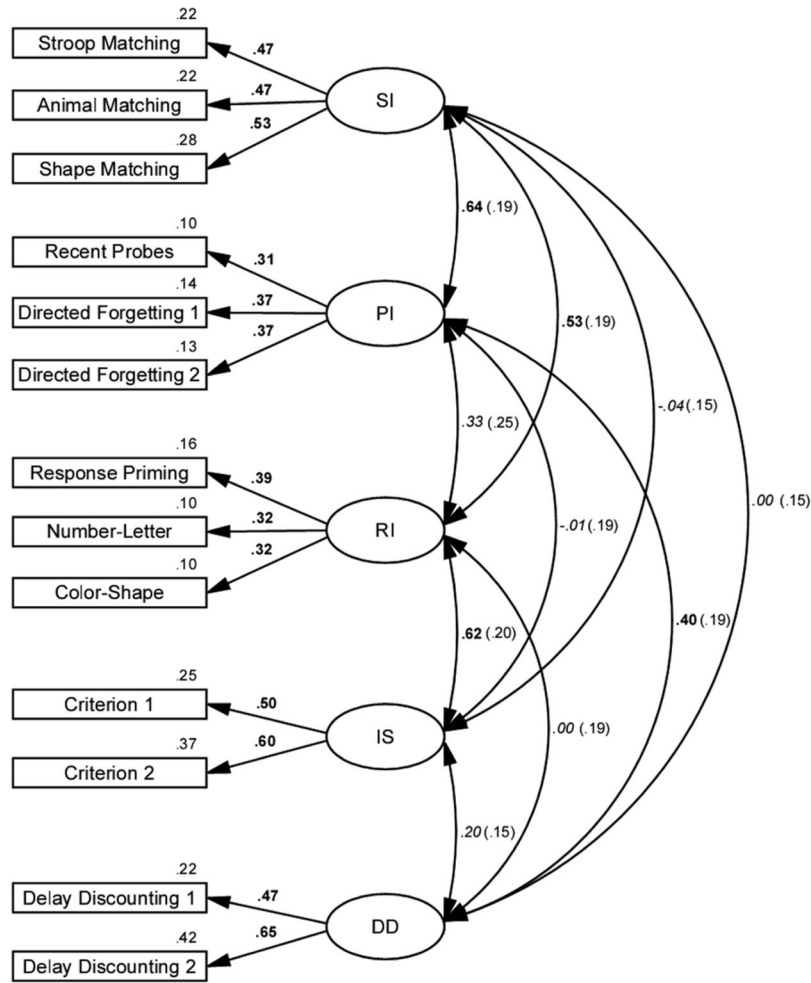

Figure 5. The five-factor structural equation model of behavioral impulsivity (stimulus interference [SI], proactive interference [PI], response interference [RI], information sampling [IS], and delay discounting [DD]). Rectangles denote manifest indicator variables (associated numbers represent squared multiple correlations). Ellipses denote latent variables. Numbers next to the single-headed arrows are standardized factor loadings; numbers next to the double-headed arrows are correlations between latent variables (with standard errors in parentheses). Values in boldface are significantly different from zero at  $\alpha = .05$ .

**Self-report measures.** Next, we investigated relations of behavioral impulsivity factors with self-reported impulsivity. With regard to self-report measures, we expected that delay discounting would predict the delay-of-gratification score; we did not have specific hypotheses regarding the other self-report scales but expected, if any, weak relations (see above). Descriptive statistics for these measures are reported in Table 4, regression weights are reported in Table 6, and the results of SEM analyses are given in Table 7. We first analyzed the general impulsivity scales before turning to the more specific questionnaires (i.e., delay-of-gratification, WBSI, CFQ).

To investigate whether our five factors could predict self-reported impulsivity, we first computed an exploratory factor analysis using the UPPS, BIS, and SSS subscales as items. Two factors emerged, with the first reflecting Impulsivity, and the second factor reflecting Sensation-Seeking (see Appendix C). These two factors were included as criterion variables into a SEM regression model. The results of regression analyses are given in Table 6. They show that neither of

the two self-report components was significantly predicted by any of the five factors. This was confirmed by the model comparison analyses reported in Table 7 (i.e., the all-paths model fitted the data well,  $\Delta\chi^2(84) = 104.99, p = .06$ ; in that model, there were no significant paths, and the no-paths model fitted the data as well as the all-paths model,  $\Delta\chi^2(10) = 9.61, p = .48$ , indicating the lack of any substantial prediction). This finding suggests the absence of a relation between the present five factors of impulsivity and the two major dimensions of self-reported impulsivity.<sup>8</sup>

In a second step, we focused on each of the three impulsivity scales (i.e., BIS, SSS, UPPS) separately. For each scale, we included all of its subscales into the model, with correlated residuals. The resulting

<sup>8</sup>These findings did not depend on the type of exploratory factor analysis used; we repeated the analyses using different orthogonal and oblique factors, with the same pattern of results.

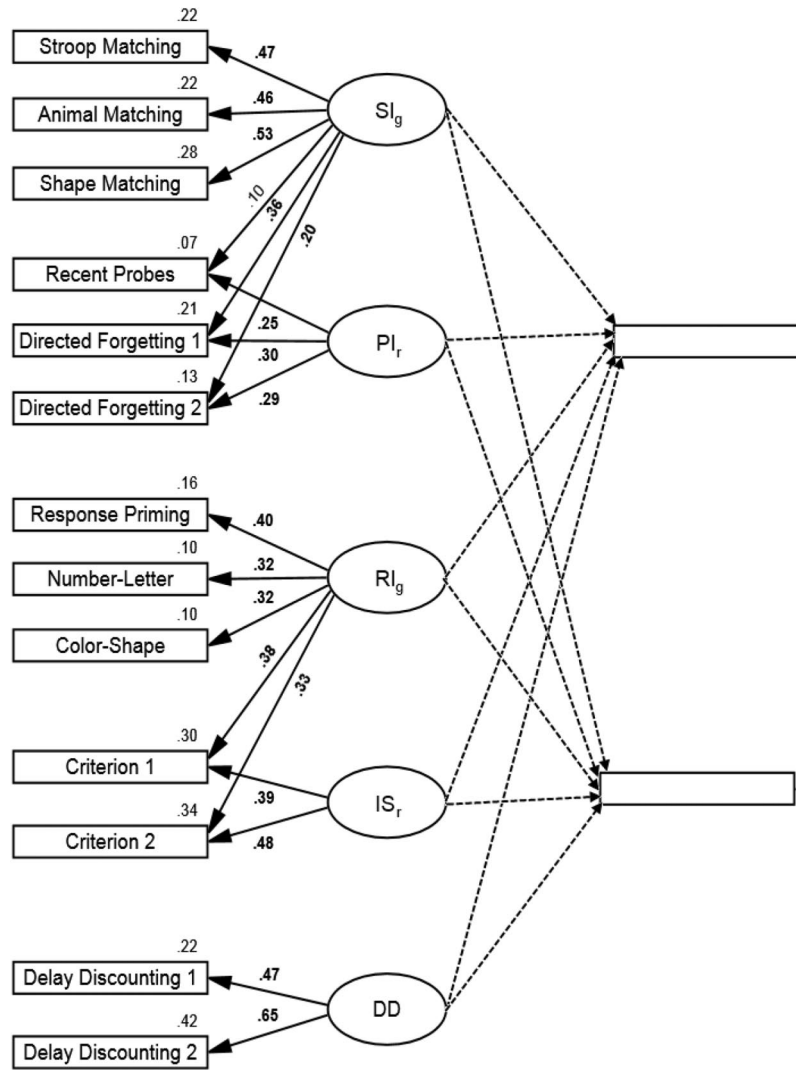

Figure 6. The nested-factor model with uncorrelated latent variables. This model was used in structural equation modeling regression analyses to investigate the relations between latent variables and different sets of criterion measures, as schematically illustrated here for a set of two (unspecified) criterion measures. SI<sub>g</sub> = stimulus interference (general factor); PI<sub>r</sub> = proactive interference (nested group factor); RI<sub>g</sub> = response interference (general factor); IS<sub>r</sub> = information sampling (nested group factor); DD = delay discounting.

regression weights are given in Table 6. None of the regression weights were significantly different from zero. Model comparison analyses further supported the interpretation that the five factors did not explain variability in self-report measures (i.e., for the BIS scale, the no-paths model fitted the data as well as the all-paths model,  $\Delta\chi^2(15) = 11.23, p = .74$ ; for the SSS scale, the  $\chi^2$  statistic was just significant,  $\chi^2(100) = 125.77, p = .04$ , but the fit of the all-paths model was acceptable, as indicated by a RMSEA clearly below .05; importantly, the no-paths model fitted the data as well as the all-paths model,  $\Delta\chi^2(20) = 18.35, p = .56$ , and it had a nonsignificant  $\chi^2$  statistic,  $\chi^2(120) = 144.10, p = .07$ ; finally, for the UPPS scale, the no-paths model fitted the data as well as the all-paths model,  $\Delta\chi^2(20) = 17.43, p = .63$ ). In sum, there was no evidence for a relation between the present behavioral impulsivity factors and self-reported impulsivity.

Finally, we turned to the delay-of-gratification, White Bear Suppression Inventory (WBSI), and Cognitive Failures Questionnaire (CFQ), using a single aggregate score for each questionnaire.<sup>9</sup> They were simultaneously included as criterion variables into a single model. Regression weights are reported in Table 6. The pattern of significant and nonsignificant estimates was confirmed by model comparison analyses (i.e., inclusion of the significant path from DD predicting delay-of-gratification resulted in an improved fit, and the final model fitted the data well; in other words, compared with the all-paths model, the fit was not harmed by dropping all paths except

<sup>9</sup> We also computed separate scores for the Unwanted Intrusive Thoughts subscale suggested by Friedman and Miyake (2004) but found that it was almost perfectly correlated with the aggregate score,  $r = .95$ .

Table 4  
Descriptive Statistics for Criterion Measures

Measure	Minimum	Maximum	<i>M</i>	<i>SD</i>	Skew	Kurtosis	Reliability
Stroop RT	−19	127	31	27	0.94	0.95	.50 <sup>a</sup>
Stroop error rate	−.12	.17	.03	.04	0.61	1.82	.38 <sup>a</sup>
Flanker RT	−27	116	35	23	0.30	1.04	.26 <sup>a</sup>
Flanker error rate	−.07	.14	.03	.04	0.37	0.41	.15 <sup>a</sup>
Stop-Signal SSRT	8	475	168	93	0.80	0.59	—
Antisaccade error difference	−.04	.13	.03	.03	0.80	0.90	.47 <sup>a</sup>
Go/No-Go commission error rate	.00	.44	.14	.09	1.06	1.16	.84 <sup>a</sup>
Impulsivity factor	−2.33	2.64	.01	1.01	0.31	−0.12	—
Sensation-Seeking factor	−2.51	2.53	.01	1.00	−0.11	−0.33	—
BIS Attention	9	25	15.08	3.29	0.49	−0.31	.63 <sup>b</sup>
BIS Motor	13	38	22.67	4.32	0.73	0.52	.67 <sup>b</sup>
BIS Non-Planning	13	39	24.78	5.14	0.29	−0.21	.74 <sup>b</sup>
SSS Thrill Seeking	10	20	16.58	2.57	−0.52	−0.49	.75 <sup>b</sup>
SSS Disinhibition	10	20	14.71	2.39	0.20	−0.58	.69 <sup>b</sup>
SSS Experience Seeking	12	20	16.97	1.66	−0.30	−0.60	.46 <sup>b</sup>
SSS Boredom Susceptibility	10	19	13.79	1.87	0.28	−0.32	.43 <sup>b</sup>
UPPS Lack of Premeditation	16	41	31.25	4.33	−0.14	0.19	.74 <sup>b</sup>
UPPS Urgency	12	44	28.17	6.25	0.10	−0.18	.85 <sup>b</sup>
UPPS Sensation-Seeking	17	52	32.73	6.61	0.12	−0.07	.79 <sup>b</sup>
UPPS Lack of Perseverance	17	39	29.58	4.65	−0.36	−0.15	.80 <sup>b</sup>
Delay of Gratification Scale	12	23	17.47	2.73	0.01	−0.71	.69 <sup>b</sup>
WBSI	15	73	40.18	12.60	0.28	−0.45	.91 <sup>b</sup>
CFQ	32	98	57.17	11.48	0.42	−0.16	.88 <sup>b</sup>
gF (Raven matrices)	1	25	11.48	4.24	0.14	0.07	.91 <sup>a</sup>
gC (Vocabulary)	21	37	30.59	3.07	−0.43	0.25	.71 <sup>a</sup>
WMC (Counting Span)	.14	1.0	.60	.22	−0.22	−0.65	.73 <sup>a</sup>
Speed	16	57	35.75	5.59	0.11	1.52	.93 <sup>a</sup>
Age	18	48	25.46	4.53	2.03	5.64	—

Note. A dash indicates that the reliability estimate could not be computed. RT = reaction time; SSRT = stop-signal reaction time; BIS = Barratt Impulsiveness Scale; SSS = Sensation-Seeking Scale; UPPS = Urgency, Premeditation, Perseverance, Sensation-Seeking Impulsive Behaviour Scale; WBSI = White Bear Suppression Inventory; CFQ = Cognitive Failures Questionnaire; WMC = working memory capacity.

<sup>a</sup> Split-half reliability, Spearman–Brown corrected. <sup>b</sup> Cronbach's alpha.

one,  $\Delta\chi^2(14) = 11.62, p = .64$ ; see also Table 7). The only significant finding was that, as expected, the delay-discounting factor predicted self-reported delay of gratification. None of the other predictions were substantial.

**General cognitive ability and age.** Finally, we explored the relations between behavioral impulsivity factors and measures of general cognitive ability (i.e., fluid and crystallized intelligence, WMC, and speed), as well as age-related variability. Regression weights are reported in Table 5, with values in boldface indicating predictions that emerged as significant in model comparison analyses. Table 7 reports the models' goodness-of-fit statistics. First, the factors were substantially related to criterion measures (i.e., the all-paths model obtained an acceptable fit; in contrast, the no-paths model fared significantly worse,  $\Delta\chi^2(25) = 71.86, p < .001$ ). There were significant paths from  $SI_g$  predicting the Raven, Counting Span, and Identical Pictures tasks, as well as age. There were also significant paths from  $PI_g$  predicting gC (i.e., Vocabulary) and Speed (i.e., Identical Pictures). The final model, containing these six paths, was well able to account for the relations between the latent variables and the set of criterion measures (i.e., its fit was comparable to that of the all-paths model,  $\Delta\chi^2(19) = 23.50, p = .22$ ).

The results obtained for the general ability measures were the same when age was controlled for (i.e., the same pattern of significant and nonsignificant paths was obtained in a model predicting the age-controlled residuals). This is consistent with the

relatively homogeneous sample (i.e., only a small number of participants were older than 30). When age served as a criterion measure, it was predicted by  $SI_g$  in a manner opposite to that observed for fluid intelligence, WMC, and speed: Older participants showed more stimulus-related interference than younger participants (this finding did not depend on the small proportion of participants older than 30; it was also observed for the remaining sample).

## Response-Related Impulsivity

An important goal of the present study was to investigate whether response-related interference can be divided into different subcomponents. As discussed above, we hypothesized that early response-selection processes may be separable from control processes at later stages (i.e., at or even after execution). Traditional behavioral inhibition tasks such as the Stop-Signal and Go/No-Go tasks have focused on late control processes: They investigate the execution versus withholding or cancellation of an already selected or initiated response. In contrast, for the RI factor included here, we selected tasks that strongly involve competition between two task-relevant responses, and thus, interference at the earlier response-selection stage. Whereas these considerations suggest that their task requirements are conceptually different, it is an empirical question whether the cognitive abilities underlying tra-

Table 5  
Path Coefficients for Structural Equation Modeling Regression Analyses of Stroop and Flanker Effects, General Cognitive Abilities, and Age

Measure	SI <sub>g</sub>	PI <sub>r</sub>	RI <sub>g</sub>	IS <sub>r</sub>	DD
Stroop and Flanker					
Stroop effect (RT)	<b>.19<sup>†</sup></b>	.26	-.22	-.17	.03
Stroop effect (Accuracy)	<b>.20<sup>†</sup></b>	-.05	.06	<b>.29<sup>†</sup></b>	.03
Flanker effect (RT)	<b>.34<sup>**</sup></b>	-.03	-.04	.01	.15
Flanker effect (Accuracy)	.04	-.31 <sup>†</sup>	<b>.24<sup>†</sup></b>	.10	.14
Stroop and Flanker (RT and Accuracy combined)					
Stroop effect	<b>.25<sup>**</sup></b>	.13	-.10	.08	.04
Flanker effect	<b>.27<sup>**</sup></b>	-.24	.15	.08	.21 <sup>†</sup>
General ability measures and age					
gF	-.47 <sup>***</sup>	-.13	-.01	.21	-.15
gC	.14	-.41 <sup>*</sup>	-.23	.08	.06
WMC	-.32 <sup>**</sup>	-.20	-.18	-.15	.01
Speed	-.33 <sup>**</sup>	-.36 <sup>*</sup>	-.03	.28	.03
Age	<b>.36<sup>***</sup></b>	-.15	-.11	.02	-.09

Note. Values in boldface indicate that a prediction emerged as significant in model comparison analyses. SI = stimulus interference; PI = proactive interference; RI = response interference; IS = information sampling; DD = delay discounting; RT = reaction time; WMC = working memory capacity.

<sup>†</sup>  $p < .10$  (two-sided). \*  $p < .05$  (two-sided). \*\*  $p < .01$  (two-sided). \*\*\*  $p < .001$  (two-sided).

ditional behavioral inhibition and the present response-selection ability are related or not.

To investigate this, we included a traditional behavioral inhibition (BI) factor into the model, with the Stop-Signal, Antisaccade, and Go/No-Go tasks as indicators, and tested whether this new factor was correlated with RI. The model yielded an acceptable fit (model no. 25, Table 3), and the indicators of the BI factor showed acceptable loadings (i.e., .35–.42) and squared multiple correlations (i.e., .12–.18). Importantly, as illustrated in Figure 7, there was no substantial correlation with RI. This is confirmed by the fact that model fit was not harmed by setting this covariance to zero,  $\Delta\chi^2(1) < 1$ ,  $p = .59$  (the BI factor was also unrelated to all other factors; none of the covariances differed from zero, all  $ps > .05$ ).<sup>10</sup> These findings demonstrate that RI and BI are separable latent variables, indicating that interference at the response-selection stage is dissociable from interference at the response-execution stage, and suggesting that response selection may be driven by different processes than the withholding or cancellation of prepotent or already-initiated responses.

To explore the prediction by BI for the Stroop and Flanker tasks, we repeated the above SEM regression analyses with a model that included the BI factor (its inclusion did not affect the pattern of predictions by the other latent factors, and thus, we do not report them again below). In line with previous findings (e.g., by Friedman & Miyake, 2004), BI strongly predicted the Stroop effect. This was true for the combined score as well as for both the RT and accuracy scores when analyzed separately (regression weights were .57, .47, and .42, respectively, all  $ps < .01$ ). In contrast, BI did not predict the Flanker effect (regression weights for com-

bined, RT, and accuracy scores were .06, -.05, and .13, respectively, all  $ps > .05$ ).<sup>11</sup>

We also explored whether BI would predict self-reported impulsivity, WBSI, CFQ, delay of gratification, or general ability measures. The only finding was that the BI factor predicted cognitive speed (the regression weight was -.30,  $p < .05$ ).<sup>12</sup> This finding replicates previous reports of a relation between speed and behavioral inhibition (e.g., Salthouse, 2005).

## General Discussion

### Summary

Using a SEM approach, we investigated the relations between five behavioral components of impulsivity, comprising the control of (1) stimulus interference, (2) proactive interference, and (3) response interference, as well as control of (4) decisional and (5) motivational impulsivity. Replicating previous research, proactive interference was separable from the other factors. Extending previous research, we found stimulus interference and response interference to be two separable, albeit closely related, components. Supporting a subdivision of response-related interference control, the present response-interference component, which reflects response-selection processes, was unrelated to a factor defined by traditional behavioral inhibition tasks that require stopping of already initiated responses or overcoming of strong prepotent responses. Further extending previous findings, we investigated relations between the three interference control functions and decisional as well as motivational impulsivity (i.e., IS and DD) and found these to be partly related, but clearly separable, in a pairwise manner, from each other as well as from the other factors.

We also investigated the latent variables' predictions for the Stroop and Flanker tasks, measures of general cognitive ability, as well as a set of self-report measures of impulsivity. First, stimulus-

<sup>10</sup> These analyses used combined scores (i.e., means of standardized RT and accuracy scores). We also computed a model using more traditional dependent variables (i.e., SSRT, Antisaccade error difference, and Go/No-Go commission errors). This model yielded an ambiguous pattern of fit statistics,  $\chi^2(99) = 138.04$ ,  $p < .01$ , RMSEA = .045, AIC = 244.04: Whereas RMSEA was still acceptable, the  $\chi^2$ -test indicated a considerable discrepancy between the estimated and observed covariance matrix. Importantly, the same pattern of results was obtained as in the model with combined scores: The covariance between RI and BI could be fixed to zero without harming model fit,  $\Delta\chi^2(1) = 1.15$ ,  $p = .28$ ; further, BI was not correlated with any other factor (all  $ps < .05$ ).

<sup>11</sup> These findings were corroborated by model comparison analyses: For the combined scores, a model with three paths (SI predicting both Stroop and Flanker, as well as BI predicting Stroop) adequately accounted for the data (i.e.,  $\chi^2(138) = 165.70$ ,  $p = .054$ , RMSEA = .034, AIC = 267.70). Compared with the all-paths model, goodness of fit was not harmed by dropping all remaining paths,  $\Delta\chi^2(9) = 8.37$ ,  $p = .50$ . For the separate RT and accuracy scores, a model with the five paths identified above (see Table 5), plus two paths from BI predicting the Stroop RT and accuracy effects, adequately accounted for the data ( $\chi^2(166) = 190.63$ ,  $p = .092$ , RMSEA = .029, AIC = 318.63). Compared with the all-paths model, fit was not harmed by dropping all remaining paths,  $\Delta\chi^2(17) = 13.03$ ,  $p = .73$ .

<sup>12</sup> This finding was corroborated by model comparison analyses: A model including a path from BI predicting cognitive speed, in addition to those identified above, described the data as well as the all-paths model,  $\Delta\chi^2(24) = 26.19$ ,  $p = .34$ , and clearly better than the no-paths model,  $\Delta\chi^2(6) = 49.88$ ,  $p < .001$ .

Table 6  
*Path Coefficients for Structural Equation Modeling Regression Analyses of Self-Report Measures*

Measure	SI <sub>g</sub>	PI <sub>r</sub>	RI <sub>g</sub>	IS <sub>r</sub>	DD
Impulsivity factors					
Impulsivity factor	.01	.00	-.17	-.05	.13
Sensation-Seeking factor	-.07	-.01	-.20	.01	-.12
BIS subscales					
BIS Attention	.06	-.03	-.12	.14	-.02
BIS Motor	.01	-.14	-.21	.03	.06
BIS Non-Planning	.06	.05	-.17	-.12	.10
SSS subscales					
SSS Thrill Seeking	.03	-.02	-.12	.11	-.10
SSS Disinhibition	-.14	.26	-.15	-.13	-.02
SSS Experience-Seeking	-.08	-.01	-.17	.08	-.01
SSS Boredom Susceptibility	-.06	-.12	-.22	-.10	-.09
UPPS subscales					
UPPS Lack of Premeditation	.06	-.24	.17	.12	-.10
UPPS Urgency	.04	.01	-.03	.04	.16
UPPS Sensation-Seeking	-.05	-.10	-.09	.00	-.10
UPPS Lack of Perseverance	.04	.16	.13	.05	-.11
Other questionnaires					
Delay of Gratification	-.19 <sup>†</sup>	.13	-.11	.03	<b>.31<sup>**</sup></b>
WBSI	-.16	.04	-.14	.04	.12
CFQ	-.09	.03	-.04	-.09	.16

*Note.* Values in boldface indicate that a path emerged as significant in model comparison analyses. SI = stimulus interference; PI = proactive interference; RI = response interference; IS = information sampling; DD = delay discounting; BIS = Barratt Impulsiveness Scale; SSS = Sensation-Seeking Scale; UPPS = Urgency, Premeditation, Perseverance, Sensation-Seeking Impulsive Behaviour Scale; WBSI = White Bear Suppression Inventory; CFQ = Cognitive Failures Questionnaire.

<sup>†</sup>  $p < .10$  (two-sided). <sup>\*\*</sup>  $p < .01$  (two-sided).

related interference predicted both the Stroop and Flanker effects, whereas the traditional behavioral impulsivity factor predicted only the Stroop effect. Second, the Stroop and Flanker accuracy scores were predicted by information sampling and response selection, respectively. Third, with the exception of the DD factor predicting delay of gratification, the behavioral impulsivity components were not predictive of self-reported facets of impulsivity. Finally, stimulus-related interference increased with age but was inversely related to gF, WMC, and cognitive speed; and proactive interference was inversely related to both gC and cognitive speed.

#### **Relations between factors: Separable but correlated.**

Whereas the five factors were clearly separable, there were a few strong relations between latent factors. First, SI was correlated with PI: Participants with higher levels of stimulus interference also showed higher proactive interference; or, inversely, control of stimulus interference was more successful in participants who were also successful in controlling proactive interference. On a conceptual level, this strong correlation can be explained if we consider the fact that an external stimulus can be subject to internal control only when its existence is represented internally; once this is so, its control likely requires processes similar to those involved in the control of representations in working memory. This implies that control processes of stimulus and proactive interference prob-

ably have some overlapping mechanisms, which is reflected here in a strong correlation. In other words, the mechanisms of selective attention that operate on external stimuli may overlap with those operating on the contents of working memory (e.g., Gazzaley & Nobre, 2012). However, this overlap is only partial: the correlation between both factors was not perfect, a model in which both factors were equated fared worse than the selected model in which both were correlated but separate factors, and the patterns of relations with criterion measures were clearly different for the two factors.

A second strong relation was observed between RI and IS. Participants with a more liberal criterion setting also showed higher levels of response interference; conversely, participants who were better able to control response interference had more conservative criterion settings (i.e., they sampled greater amounts of information before making a decision). This relation is straightforward and can be illustrated by considering the endpoints of the criterion-setting dimension, a perfectly liberal and a perfectly conservative decision criterion: With a perfectly conservative criterion, one would gather all relevant information and would therefore always arrive at the correct decision (i.e., always select the correct response). With a perfectly liberal criterion, in contrast, the first piece of information determines the response; if it happens to be irrelevant or distracting information, an incorrect decision is made (i.e., the response activated by an incompatible distracter is executed). It is therefore not surprising that participants' level of response interference was strongly related to their decision criterion setting. Note that the correlation between decisional and response-related processes may have been exaggerated somewhat by our choice of operationalization: The decision criterion estimates that were used to form the information sampling factor were based on binary decision tasks that were similar to those used to assess response-related interference. The correlation might have been less strong if we had used other measures of information sampling (e.g., Information Sampling Test: Clark et al., 2006; Matching Familiar Figures task: Kagan, 1966). Note, finally, that the correlation between latent factors was less than perfect, that a model in which both factors were equated fared worse than the selected model in which both were correlated but separate factors, and that different patterns of relations with criterion measures were obtained for both factors.

A third significant correlation was observed between SI and RI, which was significant but weaker than that observed by Friedman and Miyake (2004). Importantly, the correlation was less than perfect, and a model in which both factors were equated fared worse than the selected model in which both were correlated, but separate factors. Thus, extending the work by Friedman and Miyake, we were able to demonstrate the separability of stimulus- and response-related interference. That said, both factors were also clearly related, which is perhaps due to the common requirement of maintaining the task goal highly activated (as suggested by Friedman & Miyake, 2004, p. 115). Note that the relation between SI and RI may also have been artificially exaggerated by commonalities in the tasks used to tap both factors: All tasks presented relevant and irrelevant stimuli and required the selection of one out of two possible manual responses, and it is thus quite possible that control of stimulus-related interference may have contributed to performance in the response-interference tasks, and that control of response interference may have aided in performance on stimulus-

Table 7

Goodness-of-Fit Statistics and Model Comparison Results for Structural Equation Modeling Regression Analyses Using the Nested-Factor Model

Dependent measure	$\chi^2$	<i>df</i>	RMSEA	AIC	$\Delta\chi^2$
Stroop and Flanker, all paths	120.44	100	.032	260.44	
No paths	171.23	120	.046	271.23	50.79***
<b>Final (5 paths; see Table 5)</b>	<b>139.62</b>	<b>115</b>	<b>.033</b>	<b>249.62</b>	<b>19.17</b>
Stroop and Flanker (RT and Accuracy combined), all paths	107.49*	84	.038	209.49	
No paths	130.09**	94	.044	212.09	22.60*
<b>Final (2 paths; see Table 5)</b>	<b>117.71*</b>	<b>92</b>	<b>.038</b>	<b>203.71</b>	<b>10.22</b>
General ability measures and age, all paths	132.31	108	.035	294.31	
No paths	202.77***	133	.053	314.77	70.46***
<b>Final (6 paths; see Table 5)</b>	<b>155.81*</b>	<b>127</b>	<b>.035</b>	<b>279.81</b>	<b>23.50</b>
Impulsivity factors, all paths	104.86	84	.036	206.86	
No paths	114.36	94	.034	196.36	9.50
BIS subscales, all paths	114.57	92	.036	234.57	
No paths	125.81	107	.030	215.81	11.23
SSS subscales, all paths	125.77*	100	.036	265.77	
No paths	144.10	120	.032	244.10	18.35
UPPS subscales, all paths	120.98	100	.033	260.98	
No paths	138.40	120	.028	238.40	17.42
Other questionnaires (Delay, WBSI, CFQ), all paths	112.14	92	.034	232.14	
No paths	131.18	107	.035	221.18	19.03
<b>Final (1 path; see Table 6)</b>	<b>123.76</b>	<b>106</b>	<b>.030</b>	<b>215.76</b>	<b>11.62</b>

Note. For each set of dependent variables, the following models are reported: (1) an all-paths model containing paths from all factors to all dependent variables; (2) a “no paths” model containing no paths; (3) a “final” model in case any paths with substantial predictions were identified (i.e., the paths in boldface in Tables 5 and 6). The last column reports results of model comparisons with the all-paths model. For the no-paths model, a significant result indicates that the latent factors substantially predicted the dependent variables. For a “final” model, a nonsignificant result indicates that the latent factors’ predictions were fully accounted for by the significant paths. Selected models are in boldface. RMSEA = root-mean-square error of approximation; AIC = Akaike information criterion; RT = reaction time; BIS = Barratt Impulsiveness Scale; SSS = Sensation-Seeking Scale; UPPS = Urgency, Premeditation, Perseverance, Sensation-Seeking Impulsive Behaviour Scale; WBSI = White Bear Suppression Inventory; CFQ = Cognitive Failures Questionnaire.

\*  $p < .05$ . \*\*  $p < .01$ . \*\*\*  $p < .001$ .

interference measures. In fact, it is difficult to conceive of a measure of response-related interference without making use of task-irrelevant stimuli of some kind (and it is even harder to conceive of a measure of stimulus-related interference without making use of some kind of response). We therefore conclude that, whereas the present findings demonstrate the separability of SI and RI, the exact magnitude of their relation, uncontaminated by other factors, remains unknown.

A fourth significant correlation was observed between PI and DD. Participants who showed higher levels of proactive interference also had a stronger tendency to discount delayed rewards. In other words, participants who were less able to ignore recent information in the service of considering new information also preferred a smaller immediate reward over a larger delayed reward. This relation can be accounted for by noting that controlling proactive interference can help comparing and selecting between the two rewards: When presented with information related to the rewards, a decision in favor of the greater reward (to be received after the longer delay) is facilitated to the degree that the tempting qualities of the immediate reward can be ignored. This notion is consistent with recent theoretical development suggesting that cognitive search processes underlie delay-discounting (Kurth-Nelson, Bickel, & Redish, 2012): To determine the subjective value of a reward option, an episodic simulation is assumed to be performed to consider the reward’s features in context; and this simulation is assumed to become more difficult with increasing psychological distance of a reward option. Thus, the ease with which an episodic representation can be generated replaces tem-

poral delay as the determining factor; if this is the case, it is evident that the ability to shield and maintain cognitive representations should increase the ability to simulate the advantageous features of a greater reward to be received after a delay. Broadly speaking, this correlation would suggest that motivational impulse control (at least in the delay-discounting paradigm) may rely on more basic interference control mechanisms such as the control of proactive interference.

It might be argued that our choice of indicator variables and paradigms might have affected the magnitude of some of the latent correlations. For instance, the correlation between RI and SI might have been unduly increased by the inclusion of the number-letter task-switching paradigm: In that paradigm, an irrelevant stimulus is always presented alongside the relevant stimulus, such that selective attention (i.e., SI) is required to focus on the latter. Such an effect, if present, did not appear to be strong, however: Excluding the number-letter paradigm hardly affected the latent correlation (slightly reducing its magnitude from .53 to .49, both  $ps < .05$ ). Furthermore, the latent correlation between RI and PI could have been inflated by computing response-congruency effects across task-repetition and task-switch trials in the Number-Letter and Color-Shape tasks: Task inertia, which reflects interference by residual activation of task-sets in memory (i.e., PI), might artificially increase the magnitude of the response-congruency effect (i.e., RI), implying that participants with greater PI should also show greater RI. Empirically, however, this was not the case: The correlation between PI and RI was not significantly different from zero, and fixing it to zero did not harm model fit (see Table 3).

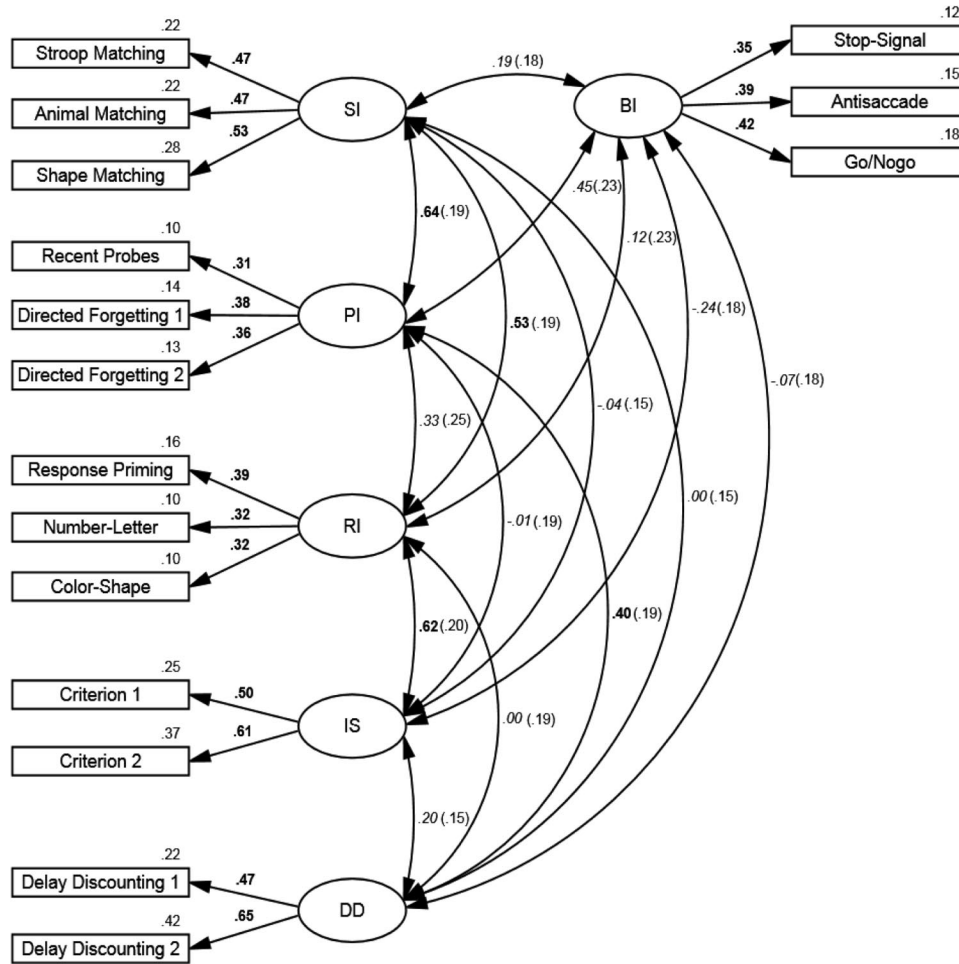

Figure 7. The six-factor model including an additional behavioral inhibition (BI) factor. SI = stimulus interference; PI = proactive interference; RI = response interference; IS = information sampling; DD = delay discounting.

Finally, it may be argued that the use of hypothetical (instead of real) monetary reward in the two delay-discounting indicator tasks limits the interpretability of the present findings in terms of reward processing. Empirical evidence, however, appears to speak against such a limitation: Several studies have failed to find an effect of reward type (hypothetical vs. real) on behavioral delay-discounting measures as well as reward-related neural signals (Bickel, Pitcock, Yi, & Angtuaco, 2009; Johnson & Bickel, 2003; Lane et al., 2003; Madden, Begotka, Raiff, & Kastern, 2003; Miyapuram, Tobler, Gregorios-Pippas, & Schultz, 2012).

**Separable subcomponents of response-related impulsivity.** The present findings demonstrate that RI and BI are separable latent variables, indicating that interference at the response-selection stage is dissociable from interference at the response-execution stage, and suggesting that response selection may be driven by different processes than the withholding or cancellation of prepotent or already-initiated responses. To our knowledge, this finding is the first to demonstrate the empirical separability of response selection from traditional behavioral inhibition in a latent-variable framework (see Figure 7). It is well consistent with

recent theoretical and neuroimaging work: For instance, in a recent review of the literature on impulse control, Aron (2011) distinguishes a reactive mode of control from a proactive and selective control mode. Whereas the former reflects the ability to stop already-initiated responses when signaled to do so (i.e., as reflected by the present BI factor), the latter refers to the goal-directed ability to selectively inhibit certain response tendencies (i.e., comparable to the present RI component). This distinction has been supported in our own recent neuroimaging work, which demonstrated dissociations between neural activity patterns supporting resolution of response-selection interference (i.e., RI) and those supporting the withholding or stopping of already-initiated responses (i.e., BI; Sebastian, Pohl, et al., 2013).

**Stimulus- and response-related components of impulsivity are separable.** In contrast to the findings reported by Friedman and Miyake (2004), the present data support the separability of SI and RI. We believe that this discrepancy is due to methodological differences: We suspect that some of the indicator tasks used by Friedman and Miyake to identify the Distracter Interference and Response Interference factors may have also tapped the respective

other factor to a substantial extent. More precisely, the Flanker task used to assess distracter interference also involves response-related interference (van Veen, Cohen, Botvinick, Stenger, & Carter, 2001; Verbruggen, Notebaert, Liefvooghe, & Vandieren-donck, 2006); similarly, the Stroop task used to assess response interference also involves stimulus interference (De Houwer, 2003; Milham et al., 2001; H. Zhang & Kornblum, 1998; Zysset, Müller, Lohmann, & von Cramon, 2001). The Stroop and Flanker tasks are structurally similar in that both require control of irrelevant and response-incompatible distracters. This can be achieved by either inhibiting the distracter stimulus, or by inhibiting the irrelevant response that is activated by the distracter stimulus. To illustrate, the Stroop task can be completed successfully not only by suppressing the prepotent response but also by suppressing the encoding of the irrelevant color word; in this case, an irrelevant response may not be triggered, so that response inhibition would not be required. Similarly, in the Flanker task, an irrelevant response can be activated by a flanking distracter stimulus if and only if it is not ignored. Thus, performance in both the Stroop and the Flanker tasks may involve the ability to ignore distracters as well as the ability to control responses.

In sum, in Friedman and Miyake's (2004) data, both tasks may have loaded on both latent variables, and therefore it is unfortunate that one was used as an indicator for Response Inhibition while another served as an indicator for Distracter Inhibition. By using the Flanker task as an indicator for Distracter Inhibition but the Stroop task as an indicator of Response Inhibition, the correlation between these two latent variables may have been artificially increased. In fact, a reanalysis (based on the correlation matrix reported in the Appendix of Friedman & Miyake, 2004) revealed that, when both indicators were removed from the model, the correlation between the latent variables dropped from .68 to .31, the latter being no longer significantly different from zero.<sup>13</sup> This finding has two implications: First, it suggests that, with a different selection of indicator tasks, distracter interference (i.e., SI) and response interference (i.e., RI) would have been separable also in Friedman and Miyake's study. Second, it supports the notion that both the Stroop and Flanker tasks involve stimulus- as well as response-related interference.

**Stimulus and response impulsivity differentially predict Stroop and Flanker effects.** The above considerations concerning the contribution of SI and RI to the Stroop and Flanker effects were supported by the present regression analyses. First, both Stroop and Flanker latency scores were predicted by stimulus-related interference: Individuals more susceptible to the influence of irrelevant distracters showed greater interference effects on RT in both tasks. In addition, Stroop accuracy scores, but not Flanker accuracy scores, were similarly predicted by stimulus interference. Thus, in the Stroop task, failing to ignore an irrelevant distracter increases the likelihood of responding to that distracter, thereby causing greater interference effects on accuracy.

In addition to the prediction by stimulus-related interference, we obtained evidence for an influence of response-related interference, which predicted Flanker accuracy: Participants who showed greater response-selection interference also tended to show greater Flanker accuracy effects. Note that SI selectively predicted the Flanker RT effect, whereas RI predicted the Flanker accuracy effect. The first prediction reflects an important role of selective-attention demands, suggesting that efficient selective top-down

attention processes can reduce the time it takes to sort out the relevant target and distracter stimuli or features, which may also involve task-goal maintenance processes. Such effects are more strongly reflected in RT differences between congruent and incongruent trials; they are unlikely to systematically favor the correct or incorrect response. In contrast, the relation between RI and Flanker accuracy reflects an important role for response-selection demands: Greater levels of response-competition (reflecting either a lower threshold or greater involuntary response activation) increase the tendency to prematurely execute an erroneous response; these phenomena are less likely to affect RT in a systematic manner (perhaps with the exception of a global increase in the speed of responses).

Further differentiating between both tasks, information sampling predicted Stroop (but not Flanker) accuracy effects: Participants setting more liberal response criteria tended to show greater Stroop effects on accuracy. As discussed above, this presumably comes about because, with a liberal criterion, responses activated by incompatible distracters are more likely to be executed.<sup>14</sup>

Finally, BI predicted the Stroop effect but not the Flanker effect. This finding supports the widely shared notion that the ability to withhold a prepotent response is required to refrain from automatically responding to the irrelevant color word. Taken together, whereas both tasks are similarly affected by stimulus interference, the present findings suggests that Stroop and Flanker tasks involve different types of response-related interference: The involuntarily activation of a prepotent response (i.e., reading the color word) is implicated as the cause of interference in the Stroop task (see also below); in contrast, in the Flanker task, interference is the consequence of the simultaneous activation of two equipotent candidate responses.

**Behavioral impulsivity is unrelated to self-reported impulsivity.** With the exception of delay of gratification, the present behavioral impulsivity factors were not related to self-reported impulsivity. This conclusion is consistent with previous findings, as illustrated by a recent meta-analysis, which yielded an estimated relation of  $r < .10$  (Cyders & Coskunpinar, 2011). This conclusion is also true for the zero-order correlations between factors and self-reported impulsivity scores: Previous research has often reported small or zero correlations between self-report scales of impulsivity and executive or interference-control functions (Reynolds et al., 2006, 2008), and the present finding of three significant bivariate correlations out of 55 (a proportion of .054) is approximately what would be expected by chance. As we had no a priori expectation about the pattern of correlation between behavioral impulsivity and self-report measures, we refrain from interpreting these correlations at this point.

<sup>13</sup> Model fit was good,  $\chi^2(12) = 7.86, p = .80$ . The covariance between Resistance to Distracter Interference and Prepotent Response Inhibition was estimated at .017, with a 95% confidence interval of  $[-0.02, 0.05]$  (in this model, the error variance of the shape-matching indicator was estimated to be negative and had to be fixed to zero). Note that a model in which Resistance to Distracter Interference and Prepotent Response Inhibition were replaced by a single common latent variable also fit the data well,  $\chi^2(13) = 10.03, p = .69$ .

<sup>14</sup> The presence of a speed-accuracy tradeoff is suggested by a null relation between IS and the combined score, resulting from a tendency toward a negative relation between IS and the RT effect.



**Behavioral impulsivity is related to general ability.** As one might expect, fluid intelligence (gF, as measured with the Raven Advanced Progressive Matrices test), WMC (i.e., counting span), and speed (as measured by a speeded picture comparison task) were related to selective attention. Specifically, the SI factor predicted performance on the Raven task: Higher levels of stimulus interference were related to lower levels of gF, implying that participants with higher gF were better able to control their attention. A similar prediction by SI emerged for WMC, reflecting the shared variability between gF and WMC (e.g., Burgess, Gray, Conway, & Braver, 2011).

Similarly, the SI factor also predicted cognitive speed. Greater levels of stimulus interference were associated with lower speed scores, suggesting that participants with greater processing speed also had better control of selective attention. In addition, speed was also predicted by the BI factor reflecting behavioral inhibition (e.g., Salthouse, 2005), a finding that has been interpreted as evidence for a fundamental role of cognitive speed, which subserves more complex cognitive operations such as behavioral inhibition. Alternatively, as discussed below, these findings may indicate that the specific ability to withhold prepotent responses might contribute to performance on processing speed measures (e.g., Hasher et al., 2007).

Another set of predictions emerged for PI. As might be expected, PI was negatively related to crystallized intelligence as well as cognitive speed. First, participants who show greater levels of proactive interference had lower levels of gC: Crystallized intelligence is known to support the resolution of proactive interference (e.g., Cornelius, Willis, Nesselroade, & Baltes, 1983; Dempster & Corkill, 1999; Unsworth, 2010). Second, participants with greater levels of proactive interference also had lower levels of cognitive speed (e.g., Hedden & Yoon, 2006).

The observed relations between latent factors and general ability measures are generally consistent with previous findings. Note that these relations can be interpreted in two directions: Some authors argue that cognitive speed is an underlying mental characteristic that affects performance on all tasks, including those used to measure inhibition and interference (Salthouse, 2005). Alternatively, speed of performance may be characterized as the result of the joint operation of basic interference control processes (e.g., Hasher et al., 2007). For instance, in the picture comparison task used here to assess cognitive speed, participants were presented with target stimuli as well as with irrelevant distracters, and were required to select one out of several responses by comparing two stimuli. Thus, for instance, the speed with which the picture comparison task was performed depended on how well participants were able to resolve interference from irrelevant stimuli or representations and select the appropriate response. Similarly, performance on the Raven task involves competing distracters and therefore also depended on participants' interference control abilities. From this perspective, the correlations reported in Table 5 can be interpreted in a relatively straightforward manner: Participants with better interference control were able to work faster and more accurate in paradigms such as the Raven and picture comparison tasks. Consistent with the fact that both tasks require a thorough analysis and comparison of several stimuli, this was especially true for the control of SI (as well as, in a similar manner, for PI).

## A Model of Behavioral Impulsivity

Recent theoretical accounts of impulsivity (as well as of compulsivity and related disorders) have pointed out the need for a better understanding of the relations between (and the separability of) different facets of impulsivity, with the goal of devising reliable behavioral intermediate endophenotypes for improving diagnostic and therapeutical applications in modern dimensional approaches to neuropsychiatric disorders (Dalley et al., 2011; Fineberg et al., 2010; Robbins, Gillan, Smith, de Wit, & Ersche, 2012). These accounts suggest that, based on clinical, animal, and neurocognitive investigations, impulsivity is at least comprised of response-related interference control (motor or stopping impulsivity), motivational impulsivity—investigated mainly in terms of delaying gratification (waiting or choice/decision-making impulsivity—not to be confused with decisional impulsivity)—and decisional impulsivity (reflection impulsivity). Several insights seem to crystallize within this line of research: First, response interference control and motivational impulsivity appear to be behaviorally and neurally related but dissociable; they can but need not concurrently occur within one group or clinical syndrome or even within one individual, in which they together (but not alone) explain a majority of behavior- or syndrome-related variance (Dalley et al., 2011; Fineberg et al., 2010; Murphy & Garavan, 2011; Reynolds et al., 2006). Second, decisional impulsivity has been linked to both interference control and motivational impulsivity (Verdejo-García et al., 2008), although tasks representing all three types of impulsivity have less frequently been systematically studied or compared within one group or clinical syndrome. Third, seemingly closely related tasks within one (sub-) domain of impulsivity (e.g., response interference) such as the Go/No-Go and the Stop-Signal tasks are in fact modulated by different transmitter systems (Eagle, Bari, & Robbins, 2008) as well as partially non-overlapping brain regions (Sebastian, Pohl, et al., 2013; Swick, Ashley, & Turken, 2011) and therefore are dissociable. Hence, a systematic assessment of the relation of stimulus-, proactive-, and response-interference, including an analysis of their relations with motivational and decisional impulsivity within the same sample, has often been demanded (Dalley et al., 2011; Eagle et al., 2008; Fineberg et al., 2010; Robbins et al., 2012). The present study provides such an assessment and presents a more comprehensive (although most certainly not complete) empirical account of the behavioral components of impulsivity. The results clearly support a multifaceted account of impulsivity: We have identified five dissociable components of impulsive behavior, relating to interfering stimuli, thoughts, and responses, as well as decisional and motivational influences. In addition, we present evidence for a subdivision of response-related impulsive behavior. Below, we discuss the components and their relations in some detail, before identifying open questions and suggesting future directions.

**Interference control.** With regard to interference control, we built upon previous empirical work, most notably by Friedman and Miyake (2004), as well as other theoretical analyses (see Table 1). Our results suggest that, in contrast to previous findings by Friedman and Miyake, the response- and distracter-interference components are separable when indicator tasks are used that correlate less, or not at all, across factors. Furthermore, the separability of proactive interference from response- and stimulus-interference was replicated with different indicator tasks that avoid potential

confoundings due to method variability. The present findings thus strengthen the tripartite structure of interference control proposed in the literature (see Table 1), while also suggesting a subdivision of response-related interference, as discussed below.

We also addressed the notion that both Stroop and Flanker effects involve stimulus- as well as response-related interference. The dimension-overlap model suggests the involvement of both types of interference (Kornblum et al., 1990), and several studies have reported supporting evidence (Milham et al., 2001; van Veen & Carter, 2005; van Veen et al., 2001; Zysset et al., 2001). We obtained further support for this notion: Interference in both tasks was predicted by stimulus-related components (SI) as well as response-related components (RI, BI). Yet, there were also differences: On the one hand, response-selection (RI) predicted the Flanker effect but not the Stroop effect; on the other hand, traditional behavioral inhibition (i.e., the BI factor) predicted the Stroop but not the Flanker effect. This finding supports previous work that has likened the Stroop (but not the Flanker) paradigm to the Stop-Signal and Antisaccade tasks (e.g., Friedman & Miyake, 2004; Hasher et al., 2007).

Since Friedman and Miyake's (2004) seminal work, numerous studies have investigated inhibition, impulse control, or interference control (a PsycINFO query yielded over 1,000 results). Several of these studies report evidence that different interference control functions, as well as their neural substrates, can be dissociated by distinguishing between the processing stages at which interference arises (Badre, 2008; Casey et al., 2000; Nee, Wager, & Jonides, 2007; Sebastian, Pohl, et al., 2013). First, stimulus interference has been dissociated from memory-based or proactive interference. A recent fMRI study reports evidence suggesting that, while there is considerable overlap (prominently involving the dorsolateral prefrontal cortex), there also exist specific and dissociable functions and neural substrates that are involved in the control of distracter interference versus proactive interference (Badre & Wagner, 2007; Nee & Jonides, 2008, 2009). For instance, in the study by Nee and Jonides (2008), proactive interference and distracter interference were uniquely associated with activation in the left dorsolateral prefrontal cortex and left occipital cortex, respectively. Similarly, proactive interference has been dissociated from response interference; different processes and neural substrates have been implied in the control of proactive interference versus the control of response interference, or response selection (Bissett et al., 2009; Nelson, Reuter-Lorenz, Sylvester, Jonides, & Smith, 2003; Zandbelt & Vink, 2010).

The evidence for a dissociation between stimulus interference and response interference is less clear. In some studies, stimulus interference has been dissociated from response interference. For instance, van Veen and colleagues have compared performance and cortical activation patterns across different types of trials in variants of the Flanker and Stroop tasks (van Veen & Carter, 2005; van Veen et al., 2001). Trials differed with regard to the levels of stimulus-related and response-related interference or conflict they induced. Performance was differentially affected by stimulus and response conflict: Stimulus conflict increased response latencies to a smaller degree than did response conflict, and only response conflict affected accuracy in the Stroop variant. Furthermore, cortical activation patterns differed across type of conflict. In contrast, other studies have concluded that stimulus interference is related to response interference (e.g., Verbruggen, Liefoghe, &

Vandierendonck, 2004, 2006). Although the notion is widely shared that control of response interference is an important function of impulse control that can—in principle—be distinguished from other functions, there is as of yet no conclusive evidence.

We propose that the inconsistency in results might be due to the fact that response-related control is not a unitary construct (Aron, 2011; Bunge & Wright, 2007; Chambers, Garavan, & Bellgrove, 2009; Schachar et al., 2007; Sebastian, Pohl, et al., 2013). Indeed, support for a dissociation between stimulus- and response-related interference comes from a meta-analysis that also suggests a partition of response-related interference into two separable components (Nee, Wagner, & Jonides, 2007). The necessity of a more fine-grained theory of response-related control processes is underlined by recent reports of dissociations between response selection and response inhibition (Bissett et al., 2009; Cai, Oldenkamp, & Aron, 2011; Schachar et al., 2007). A related theoretical development is the recent distinction between reactive and proactive stopping (see Aron, 2011, for an overview): Reactive stopping refers to stopping an already ongoing response when instructed to do so by a stop signal; in contrast, proactive stopping refers to preparations to selectively stop an upcoming response tendency.

These theoretical considerations have been supported empirically. For example, Bissett et al. (2009, Experiment 2) have investigated the relations between the requirement to select between competing responses and response inhibition by combining a version of the Go/No-Go task with a Stop-Signal task. They found that stopping was slower in a condition which contained no-go trials than in a control condition without no-go requirements; this finding is attributed to common processes underlying stopping and the withholding of a response in a no-go trial. In contrast, interference due to response selection demands did not differ across no-go conditions. Thus, resolving interference during the selection between competing responses might be dissociable from resolving interference during response execution (i.e., withholding or stopping; Aron, 2011; Band & van Boxtel, 1999; Chambers et al., 2009; Eagle et al., 2008; Goghari & MacDonald, 2009; Sebastian, Pohl, et al., 2013).

These considerations are also supported by recent neuroimaging research. A meta-analysis of fMRI studies of interference tasks found both overlapping and distinct activation across different types of tasks (Nee, Wagner, & Jonides, 2007). Specifically, activation in Go/No-Go and Stop-Signal tasks overlapped in regions implied in response execution, whereas activation in Stroop, Flanker, and Go/No-Go tasks overlapped in regions thought to mediate response selection. The authors suggest the distinction of three separable control processes for stimulus interference, response selection, and response execution. A recent fMRI study (Sebastian, Pohl, et al., 2013) suggests that an even more fine-grained analysis of processing stages might be necessary. The study distinguishes and demonstrates differences in neural activity between response selection, withholding of a selected response, and stopping or cancelling of an already initiated response. Results indicate that interference during response selection relies more pronouncedly on a fronto-parietal-pre-motor network, whereas canceling an ongoing response is more strongly associated with the indirect fronto-striatal pathway.

In line with these findings, the present study further supports the separability of two subcomponents of response-related interference control: Whereas previous research has largely focused on the

ability to overcome or stop prepotent or already-initiated responses, we have focused on the ability to resolve competition between (approximately) equipotent responses at the earlier stage of response selection. Whereas the former can be referred to as reactive stopping, the latter ability would more accurately be described as selective proactive stopping (e.g., Aron, 2011). As surmised, relations between both types of interference—response-selection based interference (i.e., the RI factor) on the one hand and the requirement to stop already initiated responses (i.e., the BI factor) on the other hand—were not obtained. Although it would be premature to draw strong conclusions from this nonsignificant correlation, the present findings are in line with previous research suggesting that selecting between competing responses and stopping ongoing responses may require different processes, or that proactive and reactive control are dissociable. Taken together, we present behavioral evidence supporting the notion that response-related control requirements may not be unitary; these findings are in line with related dissociations on the neural (see also Sebastian, Pohl, et al., 2013) and the transmitter level (Eagle et al., 2008). The empirical paradigms used here to tap response-selection interference might be used for future research into the different neural networks for reactive and proactive control.

**Decisional and motivational impulsivity.** In addition to interference control, we investigated two important aspects of impulsivity, namely participants' (liberal or conservative) decision criterion (i.e., IS), and their ability to delay reward (or, inversely, the tendency to discount delayed reward; i.e., DD). Both components were clearly distinguishable, and each of the components was separable from each of the interference control factors discussed above. Yet, there were also some substantial relations.

First, as already discussed above, the strong correlation between criterion setting and response-selection interference is quite plausible when one considers the underlying processes: A liberal criterion leads to more erroneous responses, and because erroneous responses are more likely when an incompatible response has been activated (compared to congruent situations in which no such activation is present), response interference may systematically increase with a more liberal decision criterion. Similarly, setting an appropriately conservative decision criterion implies sampling a sufficient amount of information before responding, which requires the ability to refrain from selecting responses that are based on incomplete, insufficient, or erroneous information. Without this ability, a response is executed prematurely, and information sampling is aborted. Note that the above discussion refers to a person-level estimate of criterion setting, and relations were observed with estimates of RI across subjects. It would be very interesting to investigate how these findings relate to dynamic adjustments of control that occur within-subjects on a trial-by-trial basis, for instance as a response to experienced interference (e.g., Gratton, Coles, & Donchin, 1992). The processes underlying such dynamic control are currently under active investigation, and although criterion setting, as discussed here, is perhaps an important candidate, other processes appear to be underlying dynamic adjustments of control (e.g., Botvinick, Carter, Braver, Barch, & Cohen, 2001; Mayr, Awh, & Laury, 2003).

Second, the correlation between delay discounting and proactive interference (i.e., participants with a greater tendency to prefer immediate over delayed reward were more likely to be affected by activated but no-longer-relevant cognitive representations) sug-

gests that the ability to ignore recent information is helpful in comparing the two alternatives. In other words, participants who can set aside the information about the immediate reward are better able to consider the alternative delayed reward. At this point, the above suggestion reflects a mere speculation; to our knowledge, direct evidence for this suggestion has not been reported in the literature so far. In a somewhat related strand of research, it has been suggested that working memory is required to refrain from delay discounting (e.g., Hinson, Jameson, & Whitney, 2003): Under a high WM load, participants were more likely to discount than under a low load. This would suggest a possible relation between WM capacity, which is conceptually related to PI, and delay discounting. However, these findings have been criticized for methodological reasons (e.g., Franco-Watkins, Pashler, & Rickard, 2006). More research is needed to investigate the possibility that the correlation between PI and DD can be explained by commonly shared variability with WM capacity. This notion is, however, consistent with a recent theory proposing cognitive search processes as the mechanism underlying delay-discounting (Kurth-Nelson et al., 2012): In this theory, subjective value of a reward option is the result of a mental simulation that places the reward's features in an episodic context. This simulation becomes more difficult for increasingly psychologically (i.e., not only temporally) distant rewards, leading to an advantage for closer rewards. Clearly, such mental simulations are aided by the ability to shield and maintain cognitive representations (i.e., control of PI), implying that participants who experience less PI are also better able to determine the greater magnitude of delayed rewards. Future research should assess the explanatory scope of this suggestion.

In sum, the present findings suggest the presence of substantial interactions of criterion setting and delay discounting with the interference control factors. Importantly, they support the idea that studying decisional and motivational impulsivity in concert with interference control is necessary to contribute to our understanding of the interplay of factors contributing to impulsive behavior.

**Open questions and suggestions for future research.** Based on the present results and above discussion, several predictions can be made, suggesting directions for future research. First, response interference, but not proactive interference, is independent of motivational impulsivity. On the one hand, this hypothesis is supported by an abundance of clinical and animal data (Dalley et al., 2011); on the other hand, the hypothesis encourages searching for neurally and behaviorally dissociable endophenotypes of these facets of impulsivity. As briefly discussed above, the relation between PI and DD might arise due to the episodic simulation processes underlying reward assessment that require working memory resources and are thus susceptible to PI. Experimental work should investigate this possibility in more detail.

Whereas SI and RI were strongly related, we found only weak relations between SI and BI. Yet, previous findings suggest that both factors may be related: Verbruggen et al. (2004; Verbruggen, Liefvooghe, & Vandierendonck, 2006) observed interactions between stimulus-related interference and stopping performance. Possible reasons for this discrepancy include a lack of power: It is possible that an overlap between the processes underlying SI and BI does in fact exist but may have been too weak to be detected in the present study. Alternatively, the interaction obtained by Verbruggen and colleagues may not have been due to specific stimulus- or response-related interference control abilities but may

have instead been mediated by general cognitive processes (e.g., those tapped by dual-task requirements). Another source of discrepancy may be given by the different methodological approaches: Whereas the present individual-differences approach is certainly not well-suited to test hypotheses about the interaction of underlying processes, a purely experimental approach generally does not consider trait variability. Future research should address this issue, preferably using a combination of methods, and the lack of a relation between SI and BI should be interpreted with caution until replicated elsewhere.

As discussed above, the separability of two subcomponents of response-related interference control ties in well with recent theoretical developments (Aron, 2011; Braver, 2012). The present response-selection factor RI can be interpreted as representing (selective) proactive control, whereas the traditional behavioral inhibition factor BI may more adequately be described as reflecting reactive control (although interference in Go/No-go tasks might in part also be controlled in a proactive manner). These latent factors were not (or only weakly) related, lending further empirical support for the conceptual distinction. Future research should aim at developing independent measures of proactive and reactive control, and determine the contribution of proactive and reactive control to common interference tasks such as those investigated here. In a related vein, more experimental work, replicating and extending initial findings discussed above, needs to be done to refine our understanding of the processes underlying RI and BI, and to further clarify whether and how the processes underlying the withholding a response differ from those underlying its cancellation or stopping.

Clearly, motivational aspects of impulsivity are far from exhausted by delay discounting. For instance, Sergeant (2000) discusses arousal, activation, and effort as important factors in explaining ADHD (with deficits especially prominent in activation). These factors' contribution to explaining ADHD suggests that they might play a role also in explaining nonclinical impulsivity. Performance in tasks such as those used in the present research is certainly influenced by arousal and effort, but it is notoriously difficult to separate their influence from ability. Future research might further investigate this possibility, perhaps by separately assessing, for the components identified here, both ability-related and motivation-related variability. Clarification of the interplay between the components of behavioral impulsivity and lower-level motivational factors is considered especially important because it would allow for stronger connections with neurobiological models of ADHD and other diseases (Sergeant, 2000).

## Limitations

The present study suffers from a few limitations. First, and most important, is the obvious fact that we investigated a restricted selection of components of behavioral impulsivity. Other factors have been implicated in impulsive behavior that were not included here, for example, distortion of time estimation (for a recent overview, see Cyders & Coskunpinar, 2011) or arousal (Sergeant, 2000). Thus, we do not claim to have presented a complete model of impulsivity—nor, for that matter, of the behavioral facets of impulsivity. In our view, a complete model of impulsivity is unlikely to appear soon because almost every determinant of

cognition and behavior may affect the degree of “impulsivity” that is ascribed to a given action. In the meantime, and toward this end, research should continue focusing on these more specific determinants of cognition and behavior and how they are affected by, or involved in, impulsive behavior.

A second limitation concerns the low reliability of some of the measures, which is a consequence of a necessary compromise between number of measures and number of trials per measure. Especially for difference scores computed from the Stroop and Flanker naming tasks, reliability was below traditional recommendations (note, however, that comparable reliability estimates have been reported in similar studies; e.g., Friedman & Miyake, 2004; Hedden & Yoon, 2006). Thus, it must be assumed that the scores do not fully reflect systematic variability in those tasks. Perhaps, with more reliable measures, we would have been able to demonstrate additional predictions (e.g., PI predicting Flanker accuracy, or RI and IS predicting Stroop RT). Note that this does not affect the findings discussed above; they were sufficiently robust to obtain even despite low reliability.

On a related note, our choice of measures might have affected latent correlations, for example, between SI and PI. Whereas a strong correlation between those factors might adequately reflect the tight relation between selective attention and WM, it might also be the case that using other PI measures (e.g., recall-based measures) might have yielded a lower estimate of the SI–PI correlation. In this case, perhaps, the PI factor might have contributed more to predicting criterion measures such as WMC. However, such a finding should be interpreted with caution, as a stronger relation between recall-based PI tasks and WMC might also reflect common method-specific variance. Similarly, our choice of indicator variables for the information-sampling factor might have favored the finding of a strong relation with response-selection interference: The indicators of both factors involved a speeded selection between two response alternatives, and a strong correlation might reflect common method-specific variance. More work needs to be done, using tasks involving different information-sampling demands, to determine the degree to which response-selection and information-sampling abilities are related.

Finally, it may be seen as a limitation that the present study did not include relevant clinical samples (e.g., BPD or ADHD patients). This certainly restricts the range of the investigated variables; it may also be the case that relations between components are different in special populations. The latter is of course an empirical matter, and to settle it, data from both normal and clinical samples are required in future studies. Our goal was to improve our understanding of the processes in a normal population, which can be fundamental to identifying the disturbed processes underlying certain disorders.

## Self-Reported Impulsivity

We also explored the relative contributions of the five factors to explaining variance in self-reported impulsivity. With the exception of the predicted relation between DD and the Delay-of-Gratification Scale, the present findings replicate the weak relation between behavioral and self-reported impulsivity. As exemplified for BPD in the introduction, there is an obvious dissociation between self-reported impulsivity and behavioral measures (e.g.,

Sebastian, Jacob, et al., 2013). Likewise, in our sample of healthy controls, we found only few relations between the behavioral impulsivity components and self-report measures of impulsivity. This finding is in line with a growing body of literature documenting the divergence of self-reported and behavioral impulsivity (see Cyders & Coskunpinar, 2011, for a review). Reynolds et al. (2006), for instance, systematically investigated the correlations between widely used self-report measures and behavioral measures of impulsive behavior (Stop-Signal task and Go/No-Go task, delay discounting, and Balloon Analog Risk task) in 70 healthy adult volunteers. Correlations among the self-report measures were high, but self-reports were not correlated with behavioral-task measures. Recently, Cyders and Coskunpinar (2011) performed a meta-analysis of over 20 studies examining the relationship between self-report and behavioral measures of impulsivity. They found only a small correlation ( $r < .10$ ) between both types of measures. This correlation, despite being statistically significant, indicates a rather small overlap between self-report and behavioral impulsivity. The present study, which has investigated four of the five behavioral factors considered by Cyders and Coskunpinar, as well as four of their five factors of self-reported impulsivity, adds to this body of evidence.

Given that both sets of measures—laboratory tasks as well as questionnaires—have repeatedly been shown to predict criterion measures of impulsivity, this lack of a relation suggests that they reflect different underlying constructs. One possibility (which was suggested by Cyders & Coskunpinar, 2011) is that self-report measures reflect a more stable set of general response tendencies that might be called trait impulsivity, whereas behavioral tasks tap into a more situation-specific set of processes that might be adequately described as state impulsivity. It might also be argued that the discrepancy arises because behavioral tasks objectively assess maximal ability levels of impulse control, whereas impulsivity scales reflect subjective ratings of typical impulsive behavior—that are further influenced by an individual's subjective theory of impulsivity (for similar evidence in the related domain of cognitive failures, see Wilhelm, Witthöft, & Schipolowski, 2010).

Another line of evidence suggests little congruency of traits assessed by self-report personality questionnaires with underlying biological parameters (Service et al., 2012): In an extensive meta-analytic study, stable individual differences in personality and temperament were not predicted by variability of different genetic markers (i.e., single-nucleotide polymorphisms, genes, biological pathways). Taken together, these findings raise the question about the circumstances under which laboratory measures might be incrementally valid in predicting impulsive behaviors or clinical symptoms (e.g., Jacob et al., 2010). In our view, given its enormous clinical importance, the lack of convergence in measurement approaches of impulsivity presents an urgent problem that future research should address (e.g., Dalley et al., 2011; Moeller et al., 2001). In doing so, the present findings suggest that researchers should focus not on a global “impulsivity” construct (for which we did not obtain correlations between self-report and behavioral measures) but, instead, on more specific constructs such as the ability to delay gratification (where a relation between self-report and behavioral measure was found).

## On the Nature of “Impulsivity”

The present findings are in line with a recent series of studies that have highlighted the multifaceted nature of impulsivity. Indeed, they are consistent with the view that “impulsivity” is not a construct at all: There is not one “impulsivity” factor in our model; models with a global or second-level impulsivity factor did not adequately account for the data; and the first-level factors differentially predicted criterion measures, suggesting the lack of construct homogeneity. Thus, our attempts at measuring a coherent “impulsivity” construct failed. Yet, in light of the moderate average correlation between latent factors, this is not surprising. Indeed, from the perspective of cognitive psychology, it would not appear helpful to consider selective attention, proactive interference, and response competition as parts of a single construct.

Note that the behavioral impulsivity factors we have identified in the present study are of course not only relevant for impulsive behavior; they contribute, more or less, to any type of behavior, impulsive or not. Certain patterns of scores on these constructs may yield behaviors we call impulsive, whereas other patterns would result in behaviors that are best characterized as cautious or controlled. Perhaps it would be more helpful to consider “impulsivity” not a construct (which implies a certain need for coherence; for a recent discussion, see Strauss & Smith, 2009) but a (more or less) useful description for a set of behaviors that bear a certain family resemblance, for instance, with regard to their similar (and sometimes detrimental) consequences in people's lives. For instance, impulsivity may be understood as reflecting the output of the entire system of involuntary and automatic processes (i.e., impulsive system; System 1), whereas impulse control may be taken to reflect all attempts to exert conscious and effortful influence on our behavior (i.e., reflexive system, System 2; see, e.g., Stanovich & West, 2000; Strack & Deutsch, 2004).

## Conclusions

Extending previous work (most notably by Friedman & Miyake, 2004), we found empirical support for the separability of distracter- and response-related interference; we furthermore replicated the separability of proactive interference. Beyond previous work, the present findings also support the existence of two separable types of response-related interference, separating the selection between competing responses from the withholding or stopping of already-initiated responses.

To our knowledge, the present study is the first to use SEM to additionally investigate decisional and motivational impulsivity and their relations to interference control components of impulsivity. Decisional and motivational impulsivity were related to, but clearly separable from, interference control. These two factors were investigated to reflect their important role in the clinical perspective on abnormal impulsivity. In addition, self-reported impulsivity was investigated, which has proven helpful in predicting abnormal impulsivity or lack of impulse control. Findings support conclusions from previous research that self-reported impulsivity is only weakly and selectively related to behavioral aspects of impulsivity. Taken together, these analyses support the conclusion that self-report and behavioral tasks assess different aspects of impulsive behavior. Alternatively, they suggest a lack of adequate measurement tools capable of capturing the underlying common variability in impulsivity. In our view, instead of con-

tinuing the search for an elusive (and perhaps nonexistent) coherent construct of impulsivity, researchers should investigate the set of more specific constructs that, in their interplay, predict impulsive or controlled behaviors.

## References

- Akaike, H. (1974). A new look at the statistical model identification. *IEEE Transactions on Automatic Control*, *19*, 716–723. doi:10.1109/TAC.1974.1100705
- American Psychiatric Association. (1994). *Diagnostic and statistical manual of mental disorders* (4th ed.). Washington, DC: Author.
- Arbuckle, J. L. (2006). Amos (Version 7.0) [Computer software]. Chicago, IL: SPSS.
- Aron, A. R. (2007). The neural basis of inhibition in cognitive control. *The Neuroscientist*, *13*, 214–228. doi:10.1177/1073858407299288
- Aron, A. R. (2011). From reactive to proactive and selective control: Developing a richer model for stopping inappropriate responses. *Biological Psychiatry*, *69*, e55–e68. doi:10.1016/j.biopsych.2010.07.024
- Baayen, R. H., Piepenbrock, R., & Gulikers, L. (1995). The CELEX Lexical Database [CD-ROM]. Philadelphia: University of Pennsylvania, Linguistic Data Consortium.
- Badre, D. (2008). Cognitive control, hierarchy, and the rostro-caudal organization of the frontal lobes. *Trends in Cognitive Sciences*, *12*, 193–200. doi:10.1016/j.tics.2008.02.004
- Badre, D., & Wagner, A. D. (2007). Left ventrolateral prefrontal cortex and the cognitive control of memory. *Neuropsychologia*, *45*, 2883–2901. doi:10.1016/j.neuropsychologia.2007.06.015
- Band, G. P., & van Boxtel, G. J. (1999). Inhibitory motor control in stop paradigms: Review and reinterpretation of neural mechanisms. *Acta Psychologica*, *101*, 179–211. doi:10.1016/S0001-6918(99)00005-0
- Barkley, R. A. (1997). Behavioral inhibition, sustained attention, and executive functions: Constructing a unifying theory of ADHD. *Psychological Bulletin*, *121*, 65–94. doi:10.1037/0033-2909.121.1.65
- Barratt, E. S., & Patton, J. H. (1995). *Barratt Impulsiveness Scale–11: Handbook of psychiatric measures*. Washington, DC: American Psychiatric Association.
- Beauducel, A., Strobel, A., & Brocke, B. (2003). Psychometrische Eigenschaften und Normen einer deutschsprachigen Fassung der Sensation Seeking-Skalen, Form V [Psychometric properties and norms of a German version of the Sensation-Seeking Scales, Form V]. *Diagnostica*, *49*, 61–72. doi:10.1026//0012-1924.49.2.61
- Bechara, A. (2005). Decision making, impulse control and loss of willpower to resist drugs: A neurocognitive perspective. *Nature Neuroscience*, *8*, 1458–1463. doi:10.1038/nn1584
- Berlin, H. A., & Rolls, E. T. (2004). Time perception, impulsivity, emotionality, and personality in self-harming borderline personality disorder patients. *Journal of Personality Disorders*, *18*, 358–378.
- Bickel, W. K., Pitcock, J. A., Yi, R., & Angtuaco, E. J. C. (2009). Congruence of BOLD response across intertemporal choice conditions: Fictive and real money gains and losses. *The Journal of Neuroscience*, *29*, 8839–8846. doi:10.1523/JNEUROSCI.5319-08.2009
- Bissett, P. G., Nee, D. E., & Jonides, J. (2009). Dissociating interference-control processes between memory and response. *Journal of Experimental Psychology: Learning, Memory, and Cognition*, *35*, 1306–1316. doi:10.1037/a0016537
- Blass, W. (1983). Stabilität und Spezifität des Belohnungsaufschubs bei Straftätern [Stability and specificity of delay of rewards in offenders]. In H. Kerner, H. Kury, & K. Gessar (Eds.), *Deutsche Forschungen zur Kriminalitätsentstehung und Kriminalitätskontrolle* [German research on crime and crime control] (pp. 640–680). Cologne, Germany: Heymann.
- Botvinick, M. M., Carter, C. S., Braver, T. S., Barch, D. M., & Cohen, J. D. (2001). Conflict monitoring and cognitive control. *Psychological Review*, *108*, 624–652. doi:10.1037/0033-295X.108.3.624
- Braver, T. S. (2012). The variable nature of cognitive control: A dual mechanisms framework. *Trends in Cognitive Sciences*, *16*, 106–113. doi:10.1016/j.tics.2011.12.010
- Broadbent, D. E., Cooper, P. F., Fitzgerald, P., & Parkes, K. R. (1982). The Cognitive Failures Questionnaire (CFQ) and its correlates. *British Journal of Clinical Psychology*, *21*, 1–16. doi:10.1111/j.2044-8260.1982.tb01421.x
- Bulheller, S., & Häcker, H. O. (1998). *Advanced Progressive Matrices (APM): Deutsche Bearbeitung und Normierung nach J. C. Raven* [Advanced Progressive Matrices (APM): German Revision and norms after J. C. Raven]. Frankfurt, Germany: Pearson Assessment.
- Bunge, S. A., & Wright, S. B. (2007). Neurodevelopmental changes in working memory and cognitive control. *Current Opinion in Neurobiology*, *17*, 243–250. doi:10.1016/j.conb.2007.02.005
- Burgess, G. C., Gray, J. R., Conway, A. R., & Braver, T. S. (2011). Neural mechanisms of interference control underlie the relationship between fluid intelligence and working memory span. *Journal of Experimental Psychology: General*, *140*, 674–692.
- Cai, W., Oldenkamp, C. L., & Aron, A. R. (2011). A proactive mechanism for selective suppression of response tendencies. *The Journal of Neuroscience*, *31*, 5965–5969. doi:10.1523/JNEUROSCI.6292-10.2011
- Carver, C. S., Johnson, S. L., & Joermann, J. (2008). Serotonergic function, two-mode models of self-regulation, and vulnerability to depression: What depression has in common with impulsive aggression. *Psychological Bulletin*, *134*, 912–943. doi:10.1037/a0013740
- Carver, C. S., & White, T. L. (1994). Behavioral inhibition, behavioral activation, and affective responses to impending reward and punishment: The BIS/BAS scales. *Journal of Personality and Social Psychology*, *67*, 319–333. doi:10.1037/0022-3514.67.2.319
- Casey, B. J., Thomas, K. M., Welsh, T. F., Badgaiyan, R. D., Eccard, C. H., Jennings, J. R., & Crone, E. A. (2000). Dissociation of response conflict, attentional selection, and expectancy with functional magnetic resonance imaging. *Proceedings of the National Academy of Sciences, USA*, *97*, 8728–8733. doi:10.1073/pnas.97.15.8728
- Chamberlain, S. R., & Sahakian, B. J. (2007). The neuropsychiatry of impulsivity. *Current Opinion in Psychiatry*, *20*, 255–261.
- Chambers, C. D., Garavan, H., & Bellgrove, M. A. (2009). Insights into the neural basis of response inhibition from cognitive and clinical neuroscience. *Neuroscience and Biobehavioral Reviews*, *33*, 631–646. doi:10.1016/j.neubiorev.2008.08.016
- Chapman, A. L., Leung, D. W., & Lynch, T. R. (2008). Impulsivity and emotion dysregulation in borderline personality disorder. *Journal of Personality Disorders*, *22*, 148–164. doi:10.1521/pedi.2008.22.2.148
- Christ, S. E., Kester, L. E., Bodner, K. E., & Miles, J. H. (2011). Evidence for selective inhibitory impairment in individuals with autism spectrum disorder. *Neuropsychology*, *25*, 690–701. doi:10.1037/a0024256
- Clark, L., Robbins, T. W., Ersche, K. D., & Sahakian, B. J. (2006). Reflection impulsivity in current and former substance users. *Biological Psychiatry*, *60*, 515–522. doi:10.1016/j.biopsych.2005.11.007
- Congdon, E., & Canli, T. (2008). A neurogenetic approach to impulsivity. *Journal of Personality*, *76*, 1447–1484.
- Conway, A. R. A., Kane, M. J., Bunting, M. F., Hambrick, D. Z., Wilhelm, O., & Engle, R. W. (2005). Working memory span tasks: A methodological review and user's guide. *Psychonomic Bulletin & Review*, *12*, 769–786. doi:10.3758/BF03196772
- Cornelius, S. W., Willis, S. L., Nesselroade, J. R., & Baltes, P. B. (1983). Convergence between attention variables and factors of psychometric intelligence in older adults. *Intelligence*, *7*, 253–269. doi:10.1016/0160-2896(83)90017-X
- Cyders, M. A., & Coskunpinar, A. (2011). Measurement of constructs using self-report and behavioral lab tasks: Is there overlap in nomothetic

- span and construct representation for impulsivity? *Clinical Psychology Review*, 31, 965–982. doi:10.1016/j.cpr.2011.06.001
- Dalley, J. W., Everitt, B. J., & Robbins, T. W. (2011). Impulsivity, compulsivity, and top-down cognitive control. *Neuron*, 69, 680–694. doi:10.1016/j.neuron.2011.01.020
- De Houwer, J. (2003). On the role of stimulus-response and stimulus-stimulus compatibility in the Stroop effect. *Memory & Cognition*, 31, 353–359. doi:10.3758/BF03194393
- Dempster, F. N., & Corkill, A. J. (1999). Individual differences in susceptibility to interference and general cognitive ability. *Acta Psychologica*, 101, 395–416. doi:10.1016/S0001-6918(99)00013-X
- DeSchepper, B., & Treisman, A. (1996). Visual memory for novel shapes: Implicit coding without attention. *Journal of Experimental Psychology: Learning, Memory, and Cognition*, 22, 27–47. doi:10.1037/0278-7393.22.1.27
- Dick, D. M., Smith, G., Olausson, P., Mitchell, S. H., Leeman, R. F., O'Malley, S. S., & Sher, K. (2010). Understanding the construct of impulsivity and its relationship to alcohol use disorders. *Addiction Biology*, 15, 217–226. doi:10.1111/j.1369-1600.2009.00190.x
- Dittrich, K., & Stahl, C. (2013). *Two dissociable patterns of interference in Stroop matching tasks*. Manuscript submitted for publication.
- Domes, G., Winter, B., Schnell, K., Vohs, K., Fast, K., & Herpertz, S. C. (2006). The influence of emotions on inhibitory functioning in borderline personality disorder. *Psychological Medicine*, 36, 1163–1172. doi:10.1017/S0033291706007756
- Du, W., Green, L., & Myerson, J. (2002). Cross-cultural comparisons of discounting delayed and probabilistic rewards. *The Psychological Record*, 52, 479–492.
- Eagle, D. M., Bari, A., & Robbins, T. W. (2008). The neuropsychopharmacology of action inhibition: Cross-species translation of the stop-signal and go/no-go tasks. *Psychopharmacology*, 199, 439–456. doi:10.1007/s00213-008-1127-6
- Ekstrom, R. B., French, J. W., & Harman, H. H. (1976). *Manual for the kit of factor-referenced cognitive tests*. Princeton, NJ: Educational Testing Service.
- Enders, C. K., & Bandalos, D. L. (2001). The relative performance of full information maximum likelihood estimation for missing data in structural equation models. *Structural Equation Modeling*, 8, 430–457. doi:10.1207/S15328007SEM0803\_5
- Enright, S. J., & Beech, A. R. (1993). Reduced cognitive inhibition in obsessive-compulsive disorder. *British Journal of Clinical Psychology*, 32, 67–74. doi:10.1111/j.2044-8260.1993.tb01028.x
- Enticott, P. G., & Ogloff, J. R. P. (2006). Elucidation of impulsivity. *Australian Psychologist*, 41, 3–14. doi:10.1080/00050060500391894
- Eriksen, B. A., & Eriksen, C. W. (1974). Effects of noise letters upon the identification of a target letter in a nonsearch task. *Perception & Psychophysics*, 16, 143–149. doi:10.3758/BF03203267
- Evenden, J. L. (1999). Varieties of impulsivity. *Psychopharmacology*, 146, 348–361. doi:10.1007/PL00005481
- Fineberg, N. A., Potenza, M. N., Chamberlain, S. R., Berlin, H. A., Menzies, L., Bechara, A., . . . Hollander, E. (2010). Probing compulsive and impulsive behaviors, from animal models to endophenotypes: A narrative review. *Neuropsychopharmacology*, 35, 591–604. doi:10.1038/npp.2009.185
- Franco-Watkins, A. M., Pashler, H., & Rickard, T. C. (2006). Does working memory load lead to greater impulsivity? Commentary on Hinson, Jameson, and Whitney (2003). *Journal of Experimental Psychology: Learning, Memory, and Cognition*, 32, 443–447. doi:10.1037/0278-7393.32.2.443
- Franke, G. H. (1995). *SCL-90-R: Die Symptom-Checkliste von Derogatis—Deutsche version—Manual [SCL-90-R: The symptom check list by Derogatis—German version—Manual]*. Göttingen, Germany: Beltz.
- Friedman, N. P., & Miyake, A. (2004). The relations among inhibition and interference control functions: A latent-variable analysis. *Journal of Experimental Psychology: General*, 133, 101–135. doi:10.1037/0096-3445.133.1.101
- Fuster, J. M. (2004). Upper processing stages of the perception–action cycle. *Trends in Cognitive Sciences*, 8, 143–145. doi:10.1016/j.tics.2004.02.004
- Gazzaley, A., & Nobre, A. C. (2012). Top-down modulation: Bridging selective attention and working memory. *Trends in Cognitive Sciences*, 16, 129–135. doi:10.1016/j.tics.2011.11.014
- Goghari, V. M., & MacDonald, A. W. (2009). The neural basis of cognitive control: Response selection and inhibition. *Brain and Cognition*, 71, 72–83. doi:10.1016/j.bandc.2009.04.004
- Goldfarb, L., & Henik, A. (2006). New data analysis of the Stroop matching task calls for a reevaluation of theory. *Psychological Science*, 17, 96–100. doi:10.1111/j.1467-9280.2006.01670.x
- Gratton, G., Coles, M. G. H., & Donchin, E. (1992). Optimizing the use of information: Strategic control of activation of responses. *Journal of Experimental Psychology: General*, 121, 480–506. doi:10.1037/0096-3445.121.4.480
- Green, L., & Myerson, J. (2004). A discounting framework for choice with delayed and probabilistic rewards. *Psychological Bulletin*, 130, 769–792. doi:10.1037/0033-2909.130.5.769
- Groman, S. M., James, A. S., & Jentsch, J. D. (2009). Poor response inhibition: At the nexus between substance abuse and attention deficit/hyperactivity disorder. *Neuroscience and Biobehavioral Reviews*, 33, 690–698. doi:10.1016/j.neubiorev.2008.08.008
- Hallett, P. E. (1978). Primary and secondary saccades to goals defined by instructions. *Vision Research*, 18, 1279–1296. doi:10.1016/0042-6989(78)90218-3
- Hare, T. A., Camerer, C. F., & Rangel, A. (2009, May 1). Self-control in decision-making involves modulation of the vmPFC valuation system. *Science*, 324, 646–648. doi:10.1126/science.1168450
- Hasher, L., Lustig, C., & Zacks, R. (2007). Inhibitory mechanisms and the control of attention. In A. Conway, C. Jarrold, M. Kane, A. Miyake, & J. Towse (Eds.), *Variation in working memory* (pp. 227–249). New York, NY: Oxford University Press.
- Hasher, L., & Zacks, R. T. (1988). Working memory, comprehension, and aging: A review and a new view. *Psychology of Learning and Motivation*, 22, 193–225. doi:10.1016/S0079-7421(08)60041-9
- Heatherington, T. F., & Wagner, D. D. (2011). Cognitive neuroscience of self-regulation failure. *Trends in Cognitive Sciences*, 15, 132–139. doi:10.1016/j.tics.2010.12.005
- Hedden, T., & Yoon, C. (2006). Individual differences in executive processing predict susceptibility to interference in verbal working memory. *Neuropsychology*, 20, 511–528. doi:10.1037/0894-4105.20.5.511
- Herzog, W., & Boomsma, A. (2009). Small-sample robust estimators of noncentrality-based and incremental model fit. *Structural Equation Modeling*, 16, 1–27. doi:10.1080/10705510802561279
- Hinson, J. M., Jameson, T. L., & Whitney, P. (2003). Impulsive decision making and working memory. *Journal of Experimental Psychology: Learning, Memory, and Cognition*, 29, 298–306. doi:10.1037/0278-7393.29.2.298
- Holzinger, K. J., & Swineford, F. (1937). The bifactor method. *Psychometrika*, 2, 41–54. doi:10.1007/BF02287965
- Hu, L., & Bentler, P. M. (1998). Fit indices in covariance structure modeling: Sensitivity to underparameterized model misspecification. *Psychological Methods*, 3, 424–453. doi:10.1037/1082-989X.3.4.424
- Hu, L., & Bentler, P. M. (1999). Cutoff criteria for fit indexes in covariance structure analysis: Conventional criteria versus new alternatives. *Structural Equation Modeling*, 6, 1–55. doi:10.1080/10705519909540118
- Hutton, S. B. (2008). Cognitive control of saccadic eye movements. *Brain and Cognition*, 68, 327–340. doi:10.1016/j.bandc.2008.08.021
- Hutton, S. B., & Ettinger, U. (2006). The antisaccade task as a research tool in psychopathology: A critical review. *Psychophysiology*, 43, 302–313. doi:10.1111/j.1469-8986.2006.00403.x

- Jacob, G. A., Gutz, L., Bader, K., Lieb, K., Tüscher, O., & Stahl, C. (2010). Impulsivity in borderline personality disorder: Impairment in self-report measures, but not behavioral inhibition. *Psychopathology, 43*, 180–188. doi:10.1159/000304174
- Jacob, G. A., Zvonik, K., Kamphausen, S., Sebastian, A., Maier, S., Philippen, A., . . . Tüscher, O. (2013). Emotional modulation of motor response inhibition in women with borderline personality disorder: An fMRI study. *Journal of Psychiatry and Neuroscience, 38*, 164–172. doi:10.1503/jpn.120029
- Johnson, M. W., & Bickel, W. K. (2003). The behavioral economics of cigarette smoking: The concurrent presence of a substitute and an independent reinforcer. *Behavioural Pharmacology, 14*, 137–144. doi:10.1097/00008877-200303000-00005
- Jonides, J., Lewis, R. L., Nee, D. E., Lustig, C. A., Berman, M. G., & Moore, K. S. (2008). The mind and brain of short-term memory. *Annual Review of Psychology, 59*, 193–224. doi:10.1146/annurev.psych.59.103006.093615
- Jonides, J., & Nee, D. E. (2006). Brain mechanisms of proactive interference in working memory. *Neuroscience, 139*, 181–193. doi:10.1016/j.neuroscience.2005.06.042
- Joormann, J., Yoon, K. L., & Zetsche, U. (2007). Cognitive inhibition in depression. *Applied and Preventive Psychology, 12*, 128–139. doi:10.1016/j.appsy.2007.09.002
- Kagan, J. (1966). Reflection-impulsivity: The generality and dynamics of conceptual tempo. *Journal of Abnormal Psychology, 71*, 17–24. doi:10.1037/h0022886
- Keppel, G., & Underwood, B. J. (1962). Proactive inhibition in short-term retention of single items. *Journal of Verbal Learning and Verbal Behavior, 1*, 153–161. doi:10.1016/S0022-5371(62)80023-1
- Kessler, Y., & Meiran, N. (2010). The reaction-time task-rule congruency effect is not affected by working memory load: Further support for the activated long-term memory hypothesis. *Psychological Research, 74*, 388–399. doi:10.1007/s00426-009-0261-z
- Kiesel, A., Steinhauser, M., Wendt, M., Falkenstein, M., Jost, K., Philipp, A. M., & Koch, I. (2010). Control and interference in task switching—A review. *Psychological Bulletin, 136*, 849–874. doi:10.1037/a0019842
- Kirby, K. N., & Finch, J. C. (2010). The hierarchical structure of self-reported impulsivity. *Personality and Individual Differences, 48*, 704–713. doi:10.1016/j.paid.2010.01.019
- Klauer, K. C., Musch, J., & Eder, A. B. (2005). Priming of semantic classifications: Late and response related, or earlier and more central? *Psychonomic Bulletin & Review, 12*, 897–903. doi:10.3758/BF03196783
- Kornblum, S., Hasbroucq, T., & Osman, A. (1990). Dimensional overlap: Cognitive basis for stimulus-response compatibility—A model and taxonomy. *Psychological Review, 97*, 253–270. doi:10.1037/0033-295X.97.2.253
- Kurth-Nelson, Z., Bickel, W., & Redish, A. D. (2012). A theoretical account of cognitive effects in delay discounting. *European Journal of Neuroscience, 35*, 1052–1064. doi:10.1111/j.1460-9568.2012.08058.x
- Lampe, K., Konrad, K., Kroener, S., Fast, K., Kunert, H. J., & Herpertz, S. C. (2007). Neuropsychological and behavioural disinhibition in adult ADHD compared to borderline personality disorder. *Psychological Medicine, 37*, 1717–1729. doi:10.1017/S0033291707000517
- Lane, S. D., Cherek, D. R., Pietras, C. J., & Tcheremissina, O. V. (2003). Measurement of delay discounting using trial-by-trial consequences. *Behavioural Processes, 64*, 287–303. doi:10.1016/S0376-6357(03)00143-8
- Lappin, J. S., & Eriksen, C. W. (1966). Use of a delayed signal to stop a visual reaction-time response. *Journal of Experimental Psychology, 72*, 805–811. doi:10.1037/h0021266
- Lawrence, A. J., Luty, J., Bogdan, N. A., Sahakian, B. J., & Clark, L. (2009). Problem gamblers share deficits in impulsive decision-making with alcohol-dependent individuals. *Addiction, 104*, 1006–1015. doi:10.1111/j.1360-0443.2009.02533.x
- Lawrence, K. A., Allen, J. S., & Chanen, A. M. (2010). Impulsivity in borderline personality disorder: Reward-based decision-making and its relationship to emotional distress. *Journal of Personality Disorders, 24*, 785–799. doi:10.1521/pedi.2010.24.6.785
- LeGris, J., Links, P. S., van Reekum, R., Tannock, R., & Toplak, M. (2012). Executive function and suicidal risk in women with borderline personality disorder. *Psychiatry Research, 196*, 101–108. doi:10.1016/j.psychres.2011.10.008
- Lehrl, S. (2005). *Mehrfachwahl-Wortschatz-Intelligenztest MWT-B* [Multiple-Choice Vocabulary Intelligence Test MWT-B]. Balingen, Germany: Spitta Verlag.
- Leyton, M., Okazawa, H., Diksic, M., Paris, J., Rosa, P., Mzengeza, S., . . . Benkelfat, C. (2001). Brain regional alpha-<sup>11</sup>C]methyl-L-tryptophan trapping in impulsive subjects with borderline personality disorder. *The American Journal of Psychiatry, 158*, 775–782. doi:10.1176/appi.ajp.158.5.775
- Lipszyc, J., & Schachar, R. (2010). Inhibitory control and psychopathology: A meta-analysis of studies using the stop signal task. *Journal of the International Neuropsychological Society, 16*, 1064–1076. doi:10.1017/S1355617710000895
- Lockwood, P., Jordan, C. H., & Kunda, Z. (2002). Motivation by positive or negative role models: Regulatory focus determines who will best inspire us. *Journal of Personality and Social Psychology, 83*, 854–864. doi:10.1037/0022-3514.83.4.854
- Logan, G. D., & Cowan, W. B. (1984). On the ability to inhibit thought and action: A theory of an act of control. *Psychological Review, 91*, 295–327. doi:10.1037/0033-295X.91.3.295
- MacCallum, R. C., Browne, M. W., & Cai, L. (2006). Testing differences between nested covariance structure models: Power analysis and null hypotheses. *Psychological Methods, 11*, 19–35. doi:10.1037/1082-989X.11.1.19
- MacCallum, R. C., Browne, M. W., & Sugawara, H. M. (1996). Power analysis and determination of sample size for covariance structure modeling. *Psychological Methods, 1*, 130–149. doi:10.1037/1082-989X.1.2.130
- Madden, G. J., Begotka, A. M., Raiff, B. R., & Kastern, L. L. (2003). Delay discounting of real and hypothetical rewards. *Experimental and Clinical Psychopharmacology, 11*, 139–145. doi:10.1037/1064-1297.11.2.139
- Mardia, B. Y. K. V. (1970). Measures of multivariate skewness and kurtosis with applications. *Biometrika, 57*, 519–530. doi:10.1093/biomet/57.3.519
- Mayr, U., Awh, E., & Laurey, P. (2003). Conflict adaptation effects do not require executive control. *Nature Neuroscience, 6*, 450–452.
- Meiran, N., & Kessler, Y. (2008). The task rule congruency effect in task switching reflects activated long-term memory. *Journal of Experimental Psychology: Human Perception and Performance, 34*, 137–157. doi:10.1037/0096-1523.34.1.137
- Metcalfe, J., & Mischel, W. (1999). A hot/cool-system analysis of delay of gratification: Dynamics of willpower. *Psychological Review, 106*, 3–19. doi:10.1037/0033-295X.106.1.3
- Milham, M. P., Banich, M. T., Webb, A., Barad, V., Cohen, N. J., Wszalek, T., & Kramer, A. F. (2001). The relative involvement of anterior cingulate and prefrontal cortex in attentional control depends on nature of conflict. *Cognitive Brain Research, 12*, 467–473. doi:10.1016/S0926-6410(01)00076-3
- Mischel, W., Ayduk, O., Berman, M. G., Casey, B. J., Gotlib, I. H., Jonides, J., . . . Shoda, Y. (2011). “Willpower” over the life span: Decomposing self-regulation. *Social Cognitive and Affective Neuroscience, 6*, 252–256. doi:10.1093/scan/nsq081
- Mitchell, S. H. (1999). Measures of impulsivity in cigarette smokers and non-smokers. *Psychopharmacology, 146*, 455–464. doi:10.1007/PL00005491



- Miyake, A., Friedman, N. P., Emerson, M. J., Witzki, A. H., Howerter, H., & Wager, T. D. (2000). The unity and diversity of executive functions and their contributions to complex "frontal lobe" tasks: A latent variable analysis. *Cognitive Psychology*, *41*, 49–100. doi:10.1006/cogp.1999.0734
- Miyapuram, K. P., Tobler, P. N., Gregorios-Pippas, L., & Schultz, W. (2012). BOLD responses in reward regions to hypothetical and imaginary monetary rewards. *NeuroImage*, *59*, 1692–1699. doi:10.1016/j.neuroimage.2011.09.029
- Moeller, F. G., Barratt, E. S., Dougherty, D. M., Schmitz, J. M., & Swann, A. C. (2001). Psychiatric aspects of impulsivity. *The American Journal of Psychiatry*, *158*, 1783–1793. doi:10.1176/appi.ajp.158.11.1783
- Monsell, S. (1978). Recency, immediate recognition memory, and reaction time. *Cognitive Psychology*, *10*, 465–501. doi:10.1016/0010-0285(78)90008-7
- Munakata, Y., Herd, S. A., Chatham, C. H., Depue, B. E., Banich, M. T., & O'Reilly, R. C. (2011). A unified framework for inhibitory control. *Trends in Cognitive Sciences*, *15*, 453–459. doi:10.1016/j.tics.2011.07.011
- Murphy, P., & Garavan, H. (2011). Cognitive predictors of AUDIT scores among college students. *Drug and Alcohol Dependence*, *115*, 94–100. doi:10.1016/j.drugalcdep.2010.10.011
- Myerson, J., Green, L., & Warusawitharana, M. (2001). Area under the curve as a measure of discounting. *Journal of the Experimental Analysis of Behavior*, *76*, 235–243. doi:10.1901/jeab.2001.76-235
- Nee, D. E., & Jonides, J. (2008). Dissociable interference-control processes in perception and memory. *Psychological Science*, *19*, 490–500. doi:10.1111/j.1467-9280.2008.02114.x
- Nee, D. E., & Jonides, J. (2009). Common and distinct neural correlates of perceptual and memorial selection. *NeuroImage*, *45*, 963–975. doi:10.1016/j.neuroimage.2009.01.005
- Nee, D. E., Jonides, J., & Berman, M. G. (2007). Neural mechanisms of proactive interference-resolution. *NeuroImage*, *38*, 740–751. doi:10.1016/j.neuroimage.2007.07.066
- Nee, D. E., Wager, T. D., & Jonides, J. (2007). Interference resolution: Insights from a meta-analysis of neuroimaging tasks. *Cognitive, Affective & Behavioral Neuroscience*, *7*, 1–17. doi:10.3758/CABN.7.1.1
- Nelson, J. K., Reuter-Lorenz, P. A., Sylvester, C.-Y. C., Jonides, J., & Smith, E. E. (2003). Dissociable neural mechanisms underlying response-based and familiarity-based conflict in working memory. *Proceedings of the National Academy of Sciences, USA*, *100*, 11171–11175. doi:10.1073/pnas.1334125100
- Nigg, J. T. (2000). On inhibition/disinhibition in developmental psychopathology: Views from cognitive and personality psychology and a working inhibition taxonomy. *Psychological Bulletin*, *126*, 220–246. doi:10.1037/0033-2909.126.2.220
- Nigg, J. T. (2010). Attention-deficit/hyperactivity disorder: Endophenotypes, structure, and etiological pathways. *Current Directions in Psychological Science*, *19*, 24–29. doi:10.1177/0963721409359282
- Nigg, J. T., Silk, K. R., Stavro, G., & Miller, T. (2005). Disinhibition and borderline personality disorder. *Development and Psychopathology*, *17*, 1129–1149. doi:10.1017/S0954579405050534
- Patton, J. H., Stanford, M. S., & Barratt, E. S. (1995). Factor structure of the Barratt Impulsiveness Scale. *Journal of Clinical Psychology*, *51*, 768–774. doi:10.1002/1097-4679(199511)51:6<768::AID-JCLP2270510607>3.0.CO;2-1
- Peters, J., & Büchel, C. (2011). The neural mechanisms of inter-temporal decision-making: Understanding variability. *Trends in Cognitive Sciences*, *15*, 227–239. doi:10.1016/j.tics.2011.03.002
- Ratcliff, R. (1978). A theory of memory retrieval. *Psychological Review*, *85*, 59–108. doi:10.1037/0033-295X.85.2.59
- Raven, J., Raven, J. C., & Court, J. H. (2003). *Manual for Raven's Progressive Matrices and Vocabulary Scales*. San Antonio, TX: Harcourt Assessment.
- Reise, S. P., Moore, T. M., & Haviland, M. G. (2010). Bifactor models and rotations: Exploring the extent to which multidimensional data yield univocal scale scores. *Journal of Personality Assessment*, *92*, 544–559. doi:10.1080/00223891.2010.496477
- Rentrop, M., Backenstrass, M., Jaentsch, B., Kaiser, S., Roth, A., Unger, J., . . . Renneberg, B. (2008). Response inhibition in borderline personality disorder: Performance in a go/nogo task. *Psychopathology*, *41*, 50–57. doi:10.1159/000110626
- Reynolds, B. (2006). A review of delay-discounting research with humans: Relations to drug use and gambling. *Behavioural Pharmacology*, *17*, 651–667. doi:10.1097/FBP.0b013e3280115f99
- Reynolds, B., Ortengren, A., Richards, J., & Dewit, H. (2006). Dimensions of impulsive behavior: Personality and behavioral measures. *Personality and Individual Differences*, *40*, 305–315. doi:10.1016/j.paid.2005.03.024
- Reynolds, B., Penfold, R. B., & Patak, M. (2008). Dimensions of impulsive behavior in adolescents: Laboratory behavioral assessments. *Experimental and Clinical Psychopharmacology*, *16*, 124–131. doi:10.1037/1064-1297.16.2.124
- Ridderinkhof, K. R., Forstmann, B. U., Wylie, S. A., Burle, B., & van den Wildenberg, W. P. M. (2011). Neurocognitive mechanisms of action control: Resisting the call of the Sirens. *Wiley Interdisciplinary Reviews: Cognitive Science*, *2*, 174–192. doi:10.1002/wcs.99
- Robbins, T. W., Gillan, C. M., Smith, D. G., de Wit, S., & Ersche, K. D. (2012). Neurocognitive endophenotypes of impulsivity and compulsivity: Towards dimensional psychiatry. *Trends in Cognitive Sciences*, *16*, 81–91. doi:10.1016/j.tics.2011.11.009
- Rogers, R. D., & Monsell, S. (1995). Costs of a predictable switch between simple cognitive tasks. *Journal of Experimental Psychology: General*, *124*, 207–231. doi:10.1037/0096-3445.124.2.207
- Ruchow, M., Groen, G., Kiefer, M., Buchheim, A., Walter, H., Martius, P., . . . Falkenstein, M. (2008). Response inhibition in borderline personality disorder: Event-related potentials in a go/nogo task. *Journal of Neural Transmission*, *115*, 127–133. doi:10.1007/s00702-007-0819-0
- Salthouse, T. A. (2005). Relations between cognitive abilities and measures of executive functioning. *Neuropsychology*, *19*, 532–545. doi:10.1037/0894-4105.19.4.532
- Schachar, R., Logan, G. D., Robaey, P., Chen, S., Ickowicz, A., & Barr, C. (2007). Restraint and cancellation: Multiple inhibition deficits in attention deficit hyperactivity disorder. *Journal of Abnormal Child Psychology*, *35*, 229–238. doi:10.1007/s10802-006-9075-2
- Schuermann, B., Kathmann, N., Stiglmayr, C., Renneberg, B., & Endrass, T. (2011). Impaired decision making and feedback evaluation in borderline personality disorder. *Psychological Medicine*, *41*, 1917–1927. doi:10.1017/S003329171000262X
- Sebastian, A., Jacob, G., Lieb, K., & Tüscher, O. (2013). Impulsivity in borderline personality disorder: A matter of disturbed impulse control or a facet of emotional dysregulation? *Current Psychiatry Reports*, *15*, 339–346. doi:10.1007/s11920-012-0339-y
- Sebastian, A., Pohl, M. F., Klöppel, S., Feige, B., Lange, T., Stahl, C., . . . Tüscher, O. (2013). Disentangling common and specific neural subprocesses of response inhibition. *NeuroImage*, *64*, 601–615. doi:10.1016/j.neuroimage.2012.09.020
- Sergeant, J. (2000). The cognitive-energetic model: An empirical approach to attention-deficit hyperactivity disorder. *Neuroscience and Biobehavioral Reviews*, *24*, 7–12. doi:10.1016/S0149-7634(99)00060-3
- Service, S. K., Verweij, K. J., Lahti, J., Congdon, E., Ekelund, J., Hintsanen, M., . . . Freimer, N. B. (2012). A genome-wide meta-analysis of association studies of Cloninger's Temperament Scales. *Translational Psychiatry*, *2*(5), e116. doi:10.1038/tp.2012.37
- Silbersweig, D., Clarkin, J. F., Goldstein, M., Kernberg, O. F., Tüscher, O., Levy, K. N., . . . Stern, E. (2007). Failure of frontolimbic inhibitory function in the context of negative emotion in borderline personality

- disorder. *The American Journal of Psychiatry*, 164, 1832–1841. doi:10.1176/appi.ajp.2007.06010126
- Stanovich, K. E., & West, R. F. (2000). Individual differences in reasoning: Implications for the rationality debate? *Behavioral and Brain Sciences*, 23, 645–665. doi:10.1017/S0140525X00003435
- Steinbeis, N., Bernhardt, B. C., & Singer, T. (2012). Impulse control and underlying functions of the left DLPFC mediate age-related and age-independent individual differences in strategic social behavior. *Neuron*, 73, 1040–1051. doi:10.1016/j.neuron.2011.12.027
- Sternberg, S. (1966, August 5). High-speed scanning in human memory. *Science*, 153, 652–654. doi:10.1126/science.153.3736.652
- Strack, F., & Deutsch, R. (2004). Reflective and impulsive determinants of social behavior. *Personality and Social Psychology Review*, 8, 220–247. doi:10.1207/s15327957pspr0803\_1
- Strauss, M. E., & Smith, G. T. (2009). Construct validity: Advances in theory and methodology. *Annual Review of Clinical Psychology*, 5, 1–25. doi:10.1146/annurev.clinpsy.032408.153639
- Swick, D., Ashley, V., & Turken, U. (2011). Are the neural correlates of stopping and not going identical? Quantitative meta-analysis of two response inhibition tasks. *NeuroImage*, 56, 1655–1665.
- Treisman, A., & Fearnley, S. (1969, May 3). The Stroop Test: Selective attention to colours and words. *Nature*, 222, 437–439. doi:10.1038/222437a0
- Unsworth, N. (2010). Interference control, working memory capacity, and cognitive abilities: A latent variable analysis. *Intelligence*, 38, 255–267. doi:10.1016/j.intell.2009.12.003
- van Veen, V., & Carter, C. S. (2005). Separating semantic conflict and response conflict in the Stroop task: A functional MRI study. *NeuroImage*, 27, 497–504. doi:10.1016/j.neuroimage.2005.04.042
- van Veen, V., Cohen, J. D., Botvinick, M., Stenger, V., & Carter, C. S. (2001). Anterior cingulate cortex, conflict monitoring, and levels of processing. *NeuroImage*, 14, 1302–1308. doi:10.1006/nimg.2001.0923
- Verbruggen, F., Liefvooghe, B., & Vandierendonck, A. (2004). The interaction between stop signal inhibition and distractor interference in the flanker and Stroop task. *Acta Psychologica*, 116, 21–37. doi:10.1016/j.actpsy.2003.12.011
- Verbruggen, F., Liefvooghe, B., & Vandierendonck, A. (2006). The effect of interference in the early processing stages on response inhibition in the stop signal task. *The Quarterly Journal of Experimental Psychology*, 59, 190–203. doi:10.1080/17470210500151386
- Verbruggen, F., Notebaert, W., Liefvooghe, B., & Vandierendonck, A. (2006). Stimulus- and response-conflict-induced cognitive control in the flanker task. *Psychonomic Bulletin & Review*, 13, 328–333. doi:10.3758/BF03193852
- Verdejo-García, A., Lawrence, A. J., & Clark, L. (2008). Impulsivity as a vulnerability marker for substance-use disorders: Review of findings from high-risk research, problem gamblers and genetic association studies. *Neuroscience and Biobehavioral Reviews*, 32, 777–810. doi:10.1016/j.neubiorev.2007.11.003
- Völker, K. A., Spitzer, C., Limberg, A., Grabe, H. J., Freyberger, H. J., & Barnow, S. (2009). Executive dysfunctions in female patients with borderline personality disorder with regard to impulsiveness and depression. *Psychotherapie Psychosomatik Medizinische Psychologie*, 59, 264–272. doi:10.1055/s-2008-1067437
- Voss, A., Rothermund, K., & Voss, J. (2004). Interpreting the parameters of the diffusion model: An empirical validation. *Memory & Cognition*, 32, 1206–1220. doi:10.3758/BF03196893
- Voss, A., & Voss, J. (2007). Fast-dm: A free program for efficient diffusion model analysis. *Behavior Research Methods*, 39, 767–775. doi:10.3758/BF03192967
- Voss, A., & Voss, J. (2008). A fast numerical algorithm for the estimation of diffusion model parameters. *Journal of Mathematical Psychology*, 52, 1–9. doi:10.1016/j.jmp.2007.09.005
- Wegner, D. M., & Zanakos, S. (1994). Chronic thought suppression. *Journal of Personality*, 62, 615–640. doi:10.1111/j.1467-6494.1994.tb00311.x
- Whiteside, S. P., & Lynam, D. R. (2001). The five factor model and impulsivity: Using a structural model of personality to understand impulsivity. *Personality and Individual Differences*, 30, 669–689. doi:10.1016/S0191-8869(00)00064-7
- Whiteside, S. P., Lynam, D. R., Miller, J. D., & Reynolds, S. K. (2005). Validation of the UPPS Impulsive Behaviour Scale: A four-factor model of impulsivity. *European Journal of Personality*, 19, 559–574. doi:10.1002/per.556
- Wilhelm, O., Witthöft, M., & Schipolowski, S. (2010). Self-reported cognitive failures: Competing measurement models and self-report correlates. *Journal of Individual Differences*, 31, 1–14. doi:10.1027/1614-0001/a000001
- World Health Organization. (2010). *International Classification of Diseases—10*. Retrieved from <http://apps.who.int/classifications/icd10/browse/2010/en>
- Zandbelt, B. B., & Vink, M. (2010). On the role of the striatum in response inhibition. *PLoS One*, 5, e13848. doi:10.1371/journal.pone.0013848
- Zhang, H., & Kornblum, S. (1998). The effects of stimulus-response mapping and irrelevant stimulus-response and stimulus-stimulus overlap in four-choice Stroop tasks with single-carrier stimuli. *Journal of Experimental Psychology: Human Perception and Performance*, 24, 3–19. doi:10.1037/0096-1523.24.1.3
- Zhang, J. X., Leung, H.-C., & Johnson, M. K. (2003). Frontal activations associated with accessing and evaluating information in working memory: An fMRI study. *NeuroImage*, 20, 1531–1539. doi:10.1016/j.neuroimage.2003.07.016
- Zuckerman, M. (1994). *Behavioral expressions and biosocial bases of sensation seeking*. Cambridge, England: Cambridge University Press.
- Zysset, S., Müller, K., Lohmann, G., & von Cramon, D. Y. (2001). Color-word matching Stroop task: Separating interference and response conflict. *NeuroImage*, 13, 29–36. doi:10.1006/nimg.2000.0665

(Appendices follow)

## Appendix A

### Correlation Matrix

Measure	1	2	3	4	5	6	7	8	9	10	11	12	13	14	15
1. Stroop matching	—														
2. Animal matching	<b>.38</b>	—													
3. Shape matching	<b>.21</b>	<b>.16</b>	—												
4. Recent probes	.09	-.08	.10	—											
5. Directed Forgetting 1	.13	.12	<b>.25</b>	<b>.17</b>	—										
6. Directed Forgetting 2	<b>.17</b>	.04	.10	.03	<b>.16</b>	—									
7. Response priming	.04	.09	.05	-.07	-.01	.10	—								
8. Number–Letter	.04	.09	.14	.14	.08	-.08	.02	—							
9. Color–Shape	.08	<b>.18</b>	.14	.01	.13	.08	<b>.15</b>	<b>.22</b>	—						
10. Criterion 1	-.06	.05	.05	-.09	.02	-.01	.07	.08	<b>.27</b>	—					
11. Criterion 2	-.06	-.07	.02	-.07	-.01	.11	.14	.06	.14	<b>.31</b>	—				
12. Delay Discounting 1	.04	-.02	-.07	.09	.06	.05	-.04	.02	-.03	.07	-.02	—			
13. Delay Discounting 2	.02	-.06	.07	<b>.15</b>	.01	.13	.01	.01	.02	<b>.17</b>	.04	<b>.31</b>	—		
14. Stop-Signal	-.07	.00	-.01	.08	-.01	-.03	-.09	.14	-.03	-.15	-.08	-.06	-.03	—	
15. Antisaccade	-.02	.04	-.09	.07	.12	.05	.06	-.04	-.06	-.07	.01	.04	.02	.06	—
16. Go/No-Go	.09	.10	<b>.21</b>	.06	<b>.21</b>	-.03	.03	.04	.09	.10	-.14	-.07	-.01	<b>.16</b>	<b>.19</b>

Note. Table contains pairwise Pearson correlations for all indicator variables used in the models. Correlations printed in boldface differ from zero at  $\alpha = .05$ .

## Appendix B

### A Nested-Factor Approach

A nested-factor model was created in which the variability shared by stimulus interference (SI) and proactive interference (PI) was modeled by an additional general factor  $SI_g$ , reflecting a common underlying stimulus-related interference component, and the variability shared by response interference (RI) and information sampling (IS) was modeled by another general factor  $RI_g$ , reflecting a common underlying response-related interference component. In this model, comparing factor loadings between the (original) specific group factors and the (newly added) general factors allows for an assessment of their relative contribution to accounting for indicator variance. For the SI indicator variables, we found that after including a general factor (i.e.,  $SI_g$ ), loadings on the SI group factor dropped to zero. This indicates that the stimulus-related general factor fully accounted for the variability of the SI group factor, factually replacing and extending it to also account for variability in the PI indicator variables. For the PI indicators, loadings on the PI group factor did not drop to zero, indicating that they share additional variability not accounted for by a SI-dominated stimulus-related interference factor  $SI_g$ . This suggests that the strong relation between SI and PI can be explained in terms of selective attention; we suspect it arises due to overlap between processes of selective attention to internal or external stimuli or representations (e.g., Gazzaley & Nobre, 2012).

The second general factor was included to account for variability in the RI and IS indicator variables. For the RI indicator variables, after including a general factor (i.e.,  $RI_g$ ), loadings on the RI group factor dropped to zero; this indicates that the response-related general factor fully accounted for the variability of the initial RI group factor, thereby replacing and extending it to also account for variability in the IS indicator variables. For the IS indicators, significant loadings on the general factor were also obtained, but loadings on the IS group factor did not drop to zero, indicating that they share additional variability not accounted for by a RI-dominated general response-related interference factor. Thus, the correlation between RI and IS may be better accounted for in terms of the processes underlying RI: It appears that common response-selection processes underlie the strong correlation between RI and IS.

These results support our interpretations of the strong correlations between SI and PI, and between RI and IS: The fact that each pair of factors share approximately 40% of their variance strongly suggests the existence of common underlying processes. Yet, the nested-factor analyses again demonstrate that each pair of factors cannot be replaced by a single factor without leaving a substantial proportion of PI and IS variability unexplained.

(Appendices continue)

To summarize, the nested-factor modeling approach allowed us to account for (most of) the covariance between the latent factors depicted in Figure 5 in a parsimonious manner (i.e., using the same number of latent variables) when SI is adapted to also account for shared variability with the PI component, resulting in a general stimulus-related interference factor  $SI_g$ , and RI is adapted to also account for shared variability with the IS component, resulting in a general response-related factor  $RI_g$ .

Furthermore, the resulting factors have the advantage of being uncorrelated, thereby removing potential problems of collinearity. This is an important advantage over the correlated-factor model depicted in Figure 5 with five correlated predictors, which would lead to substantial collinearity problems (e.g., low tolerance values below .24, high variance inflation factors; see also Footnote 5). With such dramatically inflated

confidence intervals around regression weights, regression analyses that aim at explaining criterion variance become meaningless.

The nested-factor model was used in subsequent regression analyses. Importantly, the results obtained using the nested-factor approach were corroborated by subsequent analyses with the original correlated-factor model (see Appendix D; see also Footnote 6). Thus, in effect, the present nested-factor model analyses may be viewed as a tool that helped identify relevant regression paths, to be tested in subsequent model-comparison analyses using the original correlated-factor model (these regression paths would have been difficult to identify using the correlated-factor model because, due to collinearity, regression weight estimates did not reach or even approach significance in that model).

### Appendix C

#### Factor Analysis of Self-Report Measures of Impulsivity

Measure	F1	F2
	Impulsivity	Sensation-Seeking
BIS Attention	.65	
BIS Motor	.71	
BIS Non-Planning	.84	
SSS Thrill Seeking		.83
SSS Disinhibition		.48
SSS Experience Seeking		.39
SSS Boredom Susceptibility		.45
UPPS Lack of Premeditation	.59	
UPPS Urgency	.63	
UPPS Sensation-Seeking		.90
UPPS Lack of Perseverance	.78	

*Note.* Table contains loadings of the subscales of self-report measures of impulsivity in a joint exploratory factor analysis. Values indicate factor loadings after Varimax rotation; only loadings  $> .30$  are displayed for clarity. In an alternative factor analysis additionally including the delay-of-gratification scale, this scale loaded .71 on the Impulsivity factor. F = Factor; BIS = Barratt Impulsiveness Scale; SSS = Sensation-Seeking Scale; UPPS = Urgency, Premeditation, Perseverance, Sensation-Seeking Impulsive Behaviour Scale.

(Appendices continue)

## Appendix D

## Regression Analyses Using the Correlated-Factor Model

Dependent measure	$\chi^2$	<i>df</i>	RMSEA	AIC	$\Delta\chi^2$
Stroop and Flanker, all paths	108.38	96	.027	258.38	
No paths	158.76**	115	.044	268.76	50.38***
<b>Final (5 paths; see Table 5)</b>	<b>130.07</b>	<b>110</b>	<b>.030</b>	<b>250.07</b>	<b>21.69</b>
Stroop and Flanker (RT and Accuracy combined), all paths	96.11	79	.038	208.11	
No paths	117.59*	89	.035	209.59	21.48*
<b>Final (2 paths; see Table 5)</b>	<b>106.75</b>	<b>87</b>	<b>.041</b>	<b>202.75</b>	<b>10.64</b>
General ability measures and age, all paths	120.16	103	.030	292.16	
No paths	190.30***	128	.051	312.30	71.15***
<b>Final (6 paths; see Table 5)</b>	<b>148.48</b>	<b>122</b>	<b>.034</b>	<b>282.48</b>	<b>28.32</b>
Impulsivity factors, all paths	92.90	79	.031	204.90	
<b>No paths</b>	<b>102.14</b>	<b>89</b>	<b>.028</b>	<b>194.14</b>	<b>9.24</b>
BIS subscales, all paths	102.24	87	.030	232.24	
<b>No paths</b>	<b>113.35</b>	<b>102</b>	<b>.024</b>	<b>213.35</b>	<b>11.11</b>
SSS subscales, all paths	113.53	95	.031	263.53	
<b>No paths</b>	<b>131.63</b>	<b>115</b>	<b>.027</b>	<b>241.63</b>	<b>18.10</b>
UPPS subscales, all paths	109.16	95	.027	259.16	
<b>No paths</b>	<b>125.97</b>	<b>115</b>	<b>.022</b>	<b>235.97</b>	<b>16.81</b>
Other questionnaires (Delay, WBSI, CFQ), all paths	100.05	87	.028	230.05	
No paths	118.72	102	.029	218.72	18.66
<b>Final (1 path; see Table 6)<sup>a</sup></b>	<b>111.10</b>	<b>101</b>	<b>.023</b>	<b>213.10</b>	<b>11.05</b>

*Note.* Goodness-of-fit statistics and model comparison results for structural equation modeling regression analyses using the correlated-factor model (Model 1, see Table 3 and Figure 5 of main text). In this model, paths from stimulus interference (SI), proactive interference (PI), response interference (RI), and information sampling (IS) replaced paths from SI<sub>g</sub>, PI<sub>g</sub>, RI<sub>g</sub>, and IS<sub>g</sub>, respectively. For each set of dependent variables, different models are reported: (1) an all-paths model containing paths from all factors to all dependent variables; (2) a “no paths” model containing no paths; (3) a “final” model in case any paths with substantial predictions were identified (i.e., those in boldface in Tables 5 and 6). The last column reports results of model comparisons with the all-paths model. For the no-paths model, a significant result indicates substantial predictions. For a “final” model, a nonsignificant result indicates that the latent factors’ predictions were fully accounted for by the significant paths. Selected models are in boldface. RMSEA = root-mean-square error of approximation; AIC = Akaike information criterion; RT = reaction time; BIS = Barratt Impulsiveness Scale; SSS = Sensation-Seeking Scale; UPPS = Urgency, Premeditation, Perseverance, Sensation-Seeking Impulsive Behaviour Scale; WBSI = White Bear Suppression Inventory; CFQ = Cognitive Failures Questionnaire.

<sup>a</sup> The final model, containing the significant path from delay discounting (DD) predicting the Delay-of-Gratification Scale, had a better fit than the no-paths model,  $\Delta\chi^2(1) = 7.62, p < .01$ .

\*  $p < .05$ . \*\*  $p < .01$ . \*\*\*  $p < .001$ .

Received January 7, 2012  
Revision received June 14, 2013  
Accepted June 19, 2013 ■