

EJMS Account

Towards an understanding of the mechanism of electron-capture dissociation: a historical perspective and modern ideas

Roman A. Zubarev,^{a*} Kim F. Haselmann, Bogdan Budnik, Frank Kjeldsen and Frank Jensen

Department of Chemistry, University of Southern Denmark, Odense, Denmark

Electron-capture dissociation (ECD) is a new fragmentation technique that utilizes ion–electron recombination reactions. The latter have parallels in other research fields; revealing these parallels helps to understand the ECD mechanism. An overview is given of ECD-related phenomena and of the history of ECD discovery and development. Current views on the ECD mechanism are discussed using both published and new examples.

Keywords: electron capture dissociation, ion–electron reactions, fragmentation, peptides and proteins

Introduction

The ideal fragmentation technique in tandem mass spectrometry (MS/MS) combines a number of seemingly contradictory features. First, many bonds must be cleaved in order to uniquely establish the molecular structure. Second, the fragmentation pattern should be simple to facilitate the mass spectrometric interpretation. Third, fragmentation should be faster than intramolecular rearrangements, otherwise the fragments will not reflect the original structure. Important labile bonds must remain intact, which will guarantee the preservation of the information on their location. Finally, the fragment ion intensities must be reproducible and characteristic of the molecular composition and structure.

As far as fragmentation of polypeptides is concerned, electron-capture dissociation (ECD¹) comes close to this ideal. ECD cleaves many more bonds than conventional collisionally-activated dissociation (CAD).² Almost all ECD fragment ions come from single bond cleavage, the feature that makes ECD exceptionally useful for sequencing applications.^{1–3} ECD is fast; no rearrangement besides that of the smallest entity, the hydrogen atom, has been registered.

Last, but not least, not only labile groups^{4–7} but also non-covalent bonds remain preserved in ECD.⁸

These unique features undoubtedly have roots in the very mechanism of dissociation, which must be different from that in conventional methods. Indeed, most other fragmentation techniques, such as CAD and infrared multiphoton dissociation (IRMPD), are based on the excitation of vibrational modes. The vibrational excitation (VE) is rapidly redistributed over many available degrees of freedom (intramolecular vibrational energy redistribution, IVR). The produced fragmentation depends upon the total amount of the deposited energy but not upon the way it was imparted. Consequently, MS/MS spectra obtained with different VE techniques look similar. If the fragmentation is kept within the single-bond cleavage limit, the cleaved bonds are mostly the weakest ones and not necessarily the structurally important bonds. Rearrangement reactions successfully competing with fragmentation, and the presence or absence of one group, can completely change the fragmentation pattern.⁹

In contrast, ECD is believed to be non-ergodic,¹ i.e. the cleavage happens prior to IVR. Furthermore, although the precursor ions may be the same as in VE techniques, the fragmenting species are different: ion–electron recombination turns the even-electron $[M + nH]^{n+}$ precursor ions into $[M + nH]^{(n-1)+}$ radicals. The latter have different bond strengths. These and other mechanistic differences result in different fragmentation pathways. In VE, polypeptide

^aCurrent address: Division of Ion Physics, Ångström Lab, Box 534, Uppsala University, S-751 21, Sweden. E-mail roman.zubarev@angstrom.uu.se

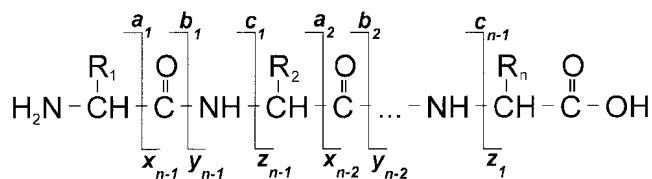
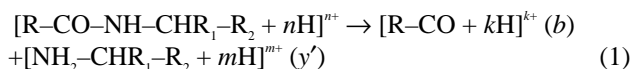

Figure 1. Peptide fragmentation nomenclature (adapted from Reference 10).

molecular ions fragment via heterolytic cleavage of the peptide bond. This produces fragments (Figure 1) denoted as b and y' using the recently introduced notation in which the prime sign denotes hydrogen atom transfer to the fragment and the absence of both the prime and radical signs means transfer from the fragment¹⁰ as in Reaction 1 where $k + m = n$.



The b , y' cleavage is favored at the N-terminal side of a proline (P) residue and at the C-terminal side of aspartic acid (D)¹¹ so that the DP combination often produces the most abundant cleavage. Also abundant are the structurally trivial low-energy channels such as the loss of water, ammonia or carbon dioxide.

In ECD, the dominant channel is the homolytic cleavage of the backbone N-C_α bond [Reaction 2, $n \geq 2$],¹

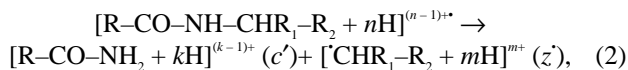

which occurs with a lesser dependence upon the nature of the neighboring amino acid residues than in VE.¹² Only the N-terminal side of proline is 100% resistant to the ECD cleavage, due to the presence of the tertiary nitrogen.¹ Yet another

ECD peculiarity is that disulfide bonds, that are typically stable in VE techniques, become preferentially cleaved upon electron capture [Reaction 3]:¹³



The observed phenomena are heuristically explained by the "hot hydrogen atom" mechanism.¹³ A fuller understanding of the ECD mechanism may be gained if ECD is viewed against the range of related phenomena known from the literature. Here, an overview is given of these phenomena as well as the history of the discovery of ECD and the present status of mechanistic studies. The main points are illustrated by both published and new examples.

History and related phenomena

Dissociative recombination

Traditionally, fragmentation following gas-phase electron capture by positive ions is termed dissociative recombination (DR), a research area that has produced more than 500 publications in the past 15 years (the ECD bibliography begins in 1998 and includes at the moment < 50 items). The initial interest in DR arose in 1931, when Kaplan attributed the oxygen green line in the night sky and in aurora to the formation of the excited atom $\text{O}(^1\text{S})$ through the dissociative recombination of electrons with O_2^{+} ions.¹⁴ Interestingly, this reaction is still under close examination.¹⁵ DR is believed to be responsible for a range of diverse phenomena in plasmas, ranging from formation of water and organic molecules in outer space¹⁶ to conversion of the electrical energy into chemical energy in the ignition of gasoline in the spark ignition engine.¹⁷ As one of the DR pioneers, Bates proposed what has become known as the direct DR mechanism [Figure 2(a)],¹⁸ in which electron capture by the molec-

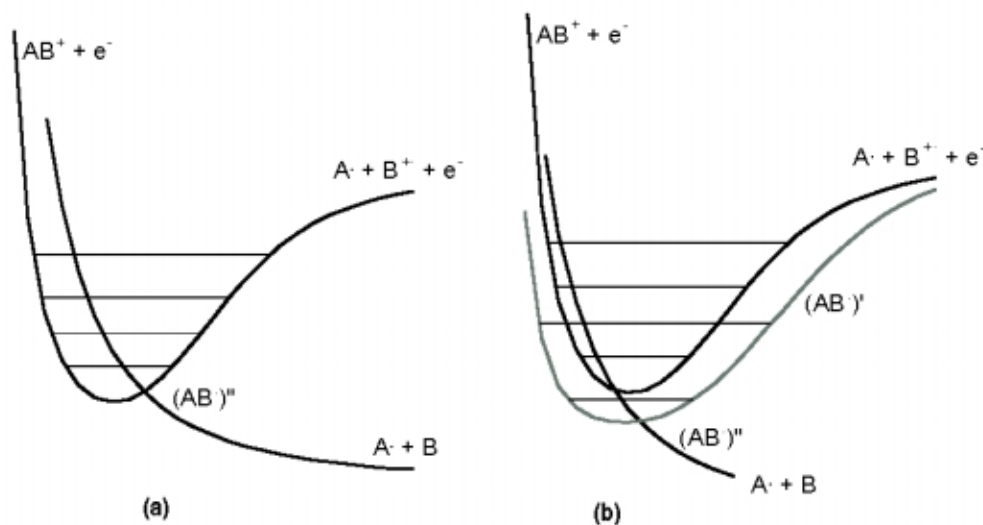

Figure 2. Dissociative recombination mechanisms: (a) direct; (b) indirect.

ular ion, AB^+ , occurs in an excited neutral state $(AB^+)^*$ that lies above the ion state, in the vicinity of its equilibrium position. This state subsequently undergoes dissociation to $A^+ + B$, with the recombination energy being transferred to the kinetic energy of the products. This picture was subsequently modified by Bradsley,¹⁹ who suggested the indirect DR mechanism in which electron capture results in a vibrationally-excited Rydberg state $(AB^+)^*$ [Figure 2(b)]. This state would, subsequently, decay by pre-dissociation via a suitable intersecting neutral state. It is now well established that the indirect process has a considerable influence on the recombination of polyatomic molecular ions.¹⁷ DR is an efficient process, especially for complex molecular ions. Recombination rates for some cluster ions reach a value of $10^{-5} \text{ cm}^3 \text{ s}^{-1}$.²⁰ These very high DR rates imply that stabilization of the electron captured in the Rydberg orbit is very fast, since the characteristic time of the reverse process, electron emission back to the continuum (autoionization), is of the order of 10^{-14} s .²¹ This puts 10^{-15} s as the upper limit for electron stabilization via bond dissociation, i.e. much faster than the typical period of molecular vibrations. Since bond breakage happens prior to recombination energy conversion and redistribution (i.e. non-ergodically), *quasi*-equilibrium-type theories such as RRKM cannot account for the DR branching ratios; the latter have to be determined experimentally.¹⁶ In DR of singly-charged hydrogen-bonded clusters (for example, water and ammonia clusters), fragmentation of proton-bridged clusters does not always take place at the site of proton location; Bates explained this by suggesting that in water clusters, for example, the charge is distributed over a large area due to the similarity of the ionization energies of hydrogen and oxygen atoms.²²

The question as to what extent the ECD mechanism is similar to that in DR is open. Phenomenologically, the difference between ECD and DR is in the charge state of the precursor ions and the products. Also, the intermediate species in ECD are necessarily hydrogen-excess radical cations (the number of extra hydrogens exceeds that of the positive charges), whereas DR researchers are rarely concerned with the electron parity of their precursor ions. The tempting aspect of declaring the two mechanisms to be similar is that this would probably put an end to the debates about ECD non-ergodicity.

The latter statement requires an additional comment. A physical chemist may insist on distinguishing between true non-ergodicity, which occurs due to VE in the ground electronic state, and trivial non-ergodicity which is due to repulsive electronic states. Avoiding the necessity to choose between different mechanisms by making this distinction, we will instead use the term “non-ergodic” for any cleavage that occurs faster than IVR.

Pulse radiolysis

In the early 1950s, interest in ion-electron recombination arose in solution-phase radiochemistry, driven by the need to understand the damaging action of ionizing radiation

on biological objects. It has been firmly established that free electrons produced in aqueous solutions rapidly form a solvation shell (e_{aq}^-) that is stable on a microsecond time scale at $3 < \text{pH} < 14$. The solvated electrons react with many organic molecules, including solvated polypeptides.²³ The rate of reaction increases greatly at lower pH due to protonation of amino acid residues. The reaction with solvated electrons



produces deamination²⁴



cleavage of inter-residue bonds

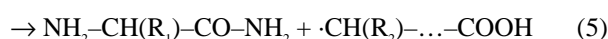

and reduction of disulfide bridges²⁵



Note the similarity between Reactions 5 and 6 and the ECD Reactions 2 and 3, respectively; ammonium loss from the reduced species is also very common in ECD. Recently, it has been shown by femtosecond pulse radiolysis experiments, that Reaction 6 with pre-solvated (free) electrons occurs in $\approx 10^{-13} \text{ s}$, i.e. on the time scale of a single intramolecular vibration.²⁶ In the gas phase, Reaction 3 must be as fast or faster, consistent with the non-ergodic mechanism.

Among simple amino acids, cysteine is by far the most reactive; the reactivity of other residues is generally determined by their pK_a values, with a higher reactivity for more basic residues.²⁵ Besides the pH value, the solution temperature plays an important role: the reaction rate of unfolded polypeptides is several times greater than that with compact native conformations. It has been proposed that the site of the solvated electron attack is the carbonyl oxygens, with fast intramolecular electron transfer along conducting bands in the molecule to sulfur bridges which show electron affinity. In oligonucleotide solutions, the main damage occurs through base loss. All these features have direct parallels with gas-phase ECD properties for the corresponding molecules.

Neutralization-reionization MS

In mass spectrometry, ion-electron recombination processes were extensively studied from the 1970s until the early 1990s with neutralization-reionization (NR) experiments. In NR MS, cations produced by electron ionization (EI) or chemical ionization (CI) are m/z -selected in a mass spectrometer analyzer, neutralized by gas-phase collisions with species possessing low ionization energies (usually alkali metal or mercury atoms) and, subsequently, reionized by EI for a second-stage mass spectrometric analysis. With this technique, short-lived unusual species were studied, such as hypervalent radicals.²⁷ Porter and co-workers, from

Cornell, have demonstrated that protonated ammonium NH_4^+ fragments upon neutralization on a very short ($< 10^{-7}$ s) time scale.²⁸ This fragmentation of the NH_4^+ hypervalent radical was non-ergodic. Later in 1986, McLafferty made a prediction that one-electron neutralization of multiply-charged proteins should produce non-ergodic backbone cleavage.²⁹ This prediction turned out to be remarkably accurate, despite the fact that the mechanisms of polypeptide protonation in the gas phase and peptide bond cleavages were poorly understood at that time.

This idea has been tested in surface-induced dissociation experiments, in which low-energy protein polycations were used to bombard a metal surface. Partial neutralization has been achieved together with *b*, *y'* products,³⁰ but no evidence for non-ergodic fragmentation has been obtained.

Electron-capture-induced dissociation (ECID)

In this technique, introduced by Beynon *et al.*, doubly-charged benzene $\text{C}_6\text{H}_6^{2+}$ ions produced by electron ionization were accelerated to several keV in a magnetic sector instrument to collide with a stationary gas (G). The ion-neutral collisions led to electron capture from the gas molecules, which in turn produced fragmentation:³¹

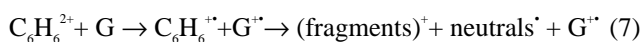

The fragmentation pattern was unusual and could not be accounted for by the statistical theory, which was explained by the presence of isolated electronic states in $\text{C}_6\text{H}_6^{+*}$. Note that the presence of "isolated electronic states" means that the system does not explore all possible states before fragmentation, i.e. shows non-ergodic behavior. ECID demonstrated promising signs of giving isomer-differentiating information,³² but the technique was difficult to use in practice and, therefore, it was finally abandoned.

Ion-ion reactions

Gas-phase ion-ion reactions with the participation of polypeptide polycations have been reported by R.D. Smith *et al.*³³ The fact that partial neutralization of electrospray-produced, multiply-protonated polypeptides with discharge-derived anions did not result in any noticeable fragmentation may come as a surprise. Indeed, electron capture (Reaction 2) and the electron transfer reaction:

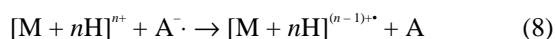

lead to the same reduced radical species. But Reaction 8 is less exothermic than Reaction 2 by the electron affinity of A. Besides, there is a competing channel to Reaction 8, the proton transfer reaction:

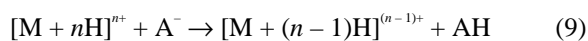

McLuckey has shown that this channel is by far the most dominant; up to nine consecutive proton transfers from polycations of apo- and holo-myoglobin have not resulted in any

fragmentation.³⁴ With a free electron, Reaction 9 would be equivalent to proton desorption:

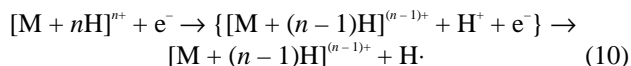

Such an outcome is unlikely because of the large difference in the effective masses of the bound proton and a free electron and the absence of a stabilizing mechanism for the hydrogen atom. Not surprisingly, hydrogen atom desorption is only a minor reaction channel in ECD.¹³ The absence of fragmentation of the cation in proton transfer (Reaction 9) is understandable since the recombination energy is deposited into the anion, leaving the cation cold. Because of the absence of fragmentation, it has been suggested that this reaction might be used to reduce the charge state of electrospray-produced ions in order to eliminate the charge state uncertainty in low-resolution mass spectrometers.³⁵

Electron impact excitation of ions from organics (EIEIO)

Reviewing the fragmentation phenomena that have common features with ECD, one cannot omit EIEIO, despite the fact that this technique does not involve electron capture. EIEIO has been proposed by Cody and Freiser³⁶ as a fragmentation reaction for singly-charged organic molecular ions in Fourier transform mass spectrometry (FT-MS):

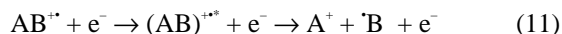

The electron energy in the original version of EIEIO was below the ionisation potential of the molecule; McLafferty and Wang later used 70 eV for a cyclic peptide.³⁷ Because of the low efficiency, the technique has been deemed impractical. No non-ergodic fragmentation has been reported, and the fragmentation pattern has been analogous to that in CAD. EIEIO largely falls in the VE category, although the presence of yet unreported isolated electronic states cannot be excluded. The relevance of EIEIO to ECD has greatly increased, however, by the discovery of a new regime, the so-called hot-electron capture dissociation (see below).

Ion-radical reactions

From the standpoint of the hot hydrogen atom mechanism, ion-radical reactions are the source of valuable mechanistic information. Unfortunately, there are rather few reports published, especially for ions containing more than just a few atoms. In an important study, Rolando *et al.* have found that bond cleavage alpha to a carbonyl group and abstraction of hydrogen alpha to a heteroatom are the major H-induced fragmentation pathways in small odd-electron organic ions.³⁸ In reactions of H^\cdot and D^\cdot with even-electron polypeptide ions, Demirev found only hydrogen exchange, but neither fragmentation, nor hydrogen abstraction or attachment.³⁹ We applied Demirev's technique to odd-electron polypeptide dications but no attachment has been observed in this case either.⁴⁰

First ECD

The first truly ECD-type mass spectra were observed in UV photodissociation experiments, where melittin (2.8 kDa) 4+ and bovine ubiquitin (8.6 kDa) 10+ ions, trapped in an FT-MS cell, were irradiated by 193 nm laser pulses.⁴¹ Along with the unusual c' , z' fragmentation, the major result of such irradiation was, surprisingly, charge reduction. Later, analysis of the same data showed that the masses of the reduced ions were also shifted by +1 Da, suggesting that the neutralized proton mostly remained incorporated in the reduced ion. When the FT cell was modified to trap cations and electrons simultaneously, the charge reduction effect and c' , z' fragmentation increased dramatically, suggesting that it was not the UV photons themselves but the secondary electrons emitted by them that were responsible for the effect. The UV laser was then replaced by a standard EI source (filament-base electron gun) and the ECD technique was born.¹

ECD on commercial instruments

The cell modification for simultaneous trapping of species of both polarities has been helpful but not essential and commercial FT-MS instruments produced by both Bruker⁴² and IonSpec^{5,7} could be used for ECD experiments without hardware modification. However, a more efficient low-energy electron source, based on an indirectly-heated dispenser cathode, implemented recently, gave a significant efficiency improvement, reducing the time needed for doing ECD experiments from seconds to milliseconds.⁸

In-source decay (ISD) in matrix-assisted laser desorption/ionization (MALDI)

Lennon and Brown have discovered that the fragment ions produced in the first 100 ns of the existence of the MALDI plume are of a different type than those in MALDI post-source decay.⁴³ Long series of c' ions have been observed in this in-source decay (ISD) process, which has facilitated sequence confirmation of entire proteins. Labile modifications of amino acid side chains, such as sulfation,⁴⁴ are preserved in ISD but are easily lost in post-source decay (PSD). Lennon and Brown have not suggested any particular mechanism, but an ECD-type process remains an obvious possibility. In most published ISD spectra, the presence of multiply-charged molecular species is evident. There are plenty of electrons as well as hot hydrogen atoms in the MALDI plume.^{45,46} The analytical utility of ISD would benefit from overcoming its low efficiency and the absence of preselection of the parent ions.

Mechanistic studies

Electron capture

The cross sections for electron capture were studied in Reference 47. Figure 3, where the capture cross section of cytochrome *c* 15+ ions is shown, demonstrates a strong

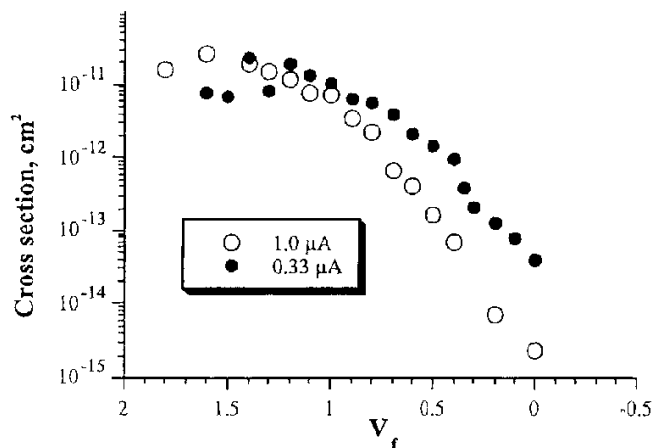

Figure 3. The capture cross section of cytochrome *c* 15+ ions measured for two emission currents from the filament cathode. V_f is the bias voltage on the cathode (positive bias means decelerating field for thermal electrons). Reproduced with permission from Reference 47.

dependence upon the electron energy. The measured capture rate increased 10^3 times when the electron energy was reduced from 1 to < 0.2 eV. This dependence appears to be stronger than is typical for dissociative recombination (DR) of small cations, which is yet to be explained. The electron capture cross section of cytochrome *c* 15+ ions measured at typical ECD conditions exceeds the ion–neutral collisional cross section by two orders of magnitude.⁴⁷ That means that the electrons are captured at distances significantly exceeding the physical dimensions of the molecular ions and that the capture is primarily Coulombic. At large capture distances, the point-charge model becomes applicable; under these circumstances, the capture distance (Thomson radius) is proportional to the ionic charge n , with the cross section proportional to n^2 . The experimental data are in a rather good agreement with this prediction.⁴⁷ In the point-charge model, the shape of the molecule, its mass, the strength of intramolecular bonds, etc. are unimportant. The experimental evidence does, however, indicate that the efficiency of electron capture is the highest for linear, fully unfolded ions.

Ion reactions also show a squared charge dependence of the reaction cross section.³⁴ The cross section also increases in DR as the electron energy approaches zero value, although this increase is less steep.²¹ It should be noted that electron capture by cations is different from that by neutral molecules. The latter is a resonance process often requiring input of energy, which leads to a threshold energy below which no electron capture occurs. On the contrary, the overall feature of DR cross sections, especially of polyatomic species, is a continuous, monotonous increase at low energies, without any threshold. There is, however, a common feature. Capture cross sections of both neutrals and cations often exhibit a local maximum at 7–10 eV, the range where electronic excitations prior to electron capture are possible. Some time ago, our group reported that ECD can occur in

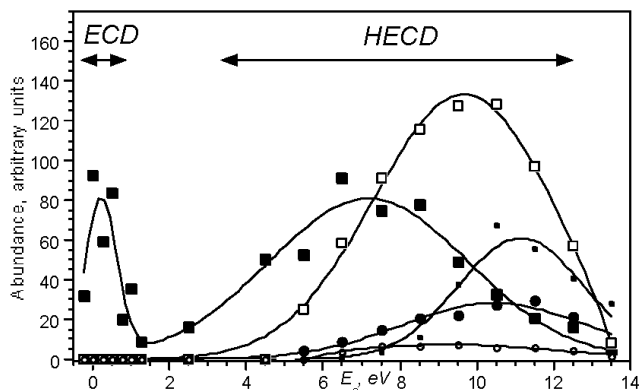

Figure 4. Fragment ion abundances versus electron energy E_e for 250 ms irradiation of molecular cations of the SRP peptide: 2+ ion, ■ N-C bond cleavages, □ peptide C-N bond cleavages, ○ z_4^{++} fragments, ● w_4^{++} fragments; 1+ ion, ▴ peptide C-N bond cleavages. Reproduced with permission from Reference 10.

that energy range.⁴⁸ Later, a more detailed study confirmed that finding, showing that the ECD cross section has a local maximum around 7 eV.¹⁰ The maximum cross section in this “hot-electron” capture dissociation (HECD) is two orders of magnitude smaller than that at < 0.2 eV. The much larger electron current produced by the indirectly-heated cathode can compensate for this factor, giving an overall efficiency in HECD similar to that in conventional ECD (Figure 4). The c' , z' fragmentation pattern in HECD is similar to that in the ECD regime, suggesting that the underlying mechanism is the same. The excess of energy in HECD produces secondary fragmentation of z' fragments, yielding w ions which allow the isomeric leucine and isoleucine residues to be distinguished.¹⁰ HECD spectra also contain other types of fragment ions, for example b , y' ions that are the result of an EIEIO-type process. Since HECD is a variant of the ECD phenomenon, below we will discuss only the conventional, low-energy ECD regime.

Intramolecular electron transfer

“Landing” of the electron at the site of charge solvation is a simplified picture, since the charge is distributed over many atoms. For example, in the triglycine molecule protonated at the central carbonyl oxygen, calculation using a fixed AMBER geometry and the RHF/NPA/6-31G** level of theory suggests that 78% of the positive charge density is concentrated on seven adjacent atoms including the proton. If the probability of electron landing is a function of the charge density, three types of events can occur. Not unexpectedly, the most probable is the capture by the proton that possesses 4/7 (57%) of the charge. Electron capture is also conceivable on the adjacent NH group that possesses 15% of the charge. Such capture would result in immediate fragmentation. Participation of other groups in electron capture is the third possibility. Together, these groups possess 27% of the charge, with even distant groups contributing signifi-

cantly. This means that primary electron capture can occur far away from the proton, at a distance of at least a few residues, with subsequent electron transfer to the site with the highest charge density (protonation site) due to the intramolecular potential difference. Such long-distance electron capture, followed by electron transfer, has been observed in reactions of polypeptides with solvated electrons in irradiated solutions. The potential difference is especially high in complexes with multiply-charged metal ions. In ECD of cytochrome c 15+ ions, the region around the heme group containing Fe^{3+} remained immune to c' , z' cleavage.⁴⁷ Similarly, the complex of angiotensin II with Zn^{2+} produced far less backbone cleavage than the doubly-protonated molecule (Figure 5). In both cases, the metal ion served as a sink for electrons that were likely transferred from the place of the original landing.

Recombination energy

The recombination energy (RE) can be estimated from Figure 6 as:

$$RE = 13.6 \text{ eV} - PA[(n-1)+] + HA[(n-1)+], \quad (12)$$

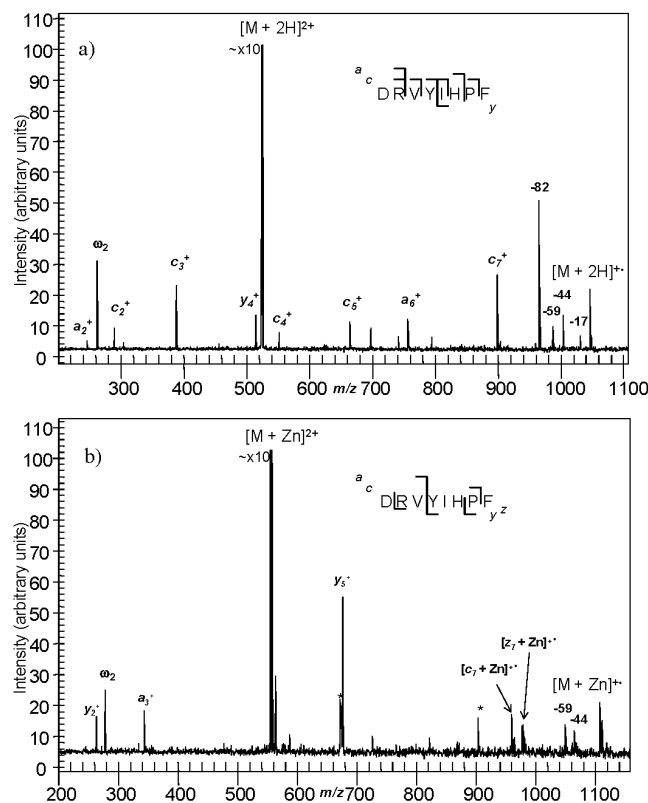

Figure 5. ECD of different types of dications of angiotensin II: (a) $[M + 2H]^{2+}$, (b) $[M + Zn]^{2+}$. The peaks marked ω_2 are due to the second harmonics of the largest peak; peaks marked with a star are due to unidentified ions left in the spectrum after imperfect precursor-ion isolation.

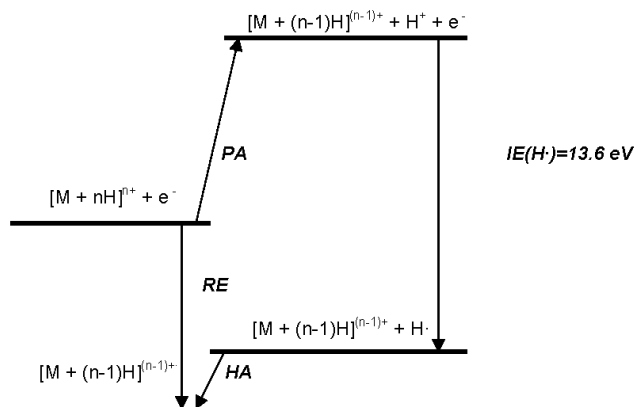
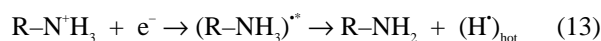

Figure 6. The thermodynamic cycle of ECD. Adapted from Reference 49.

where PA and HA are the proton and hydrogen atom affinities, respectively and $(n-1)+$ denotes a molecule with $(n-1)$ sites protonated.⁴⁹ The gas-phase proton affinity of peptides can be as high as 10.6 eV for $n=1$ but it decreases with n .⁵⁰ For electrospray-produced ions, the proton affinity cannot be much smaller than that of the solvent, approx. 8 eV. The hydrogen-atom affinity of even-electron species is, typically, rather small, < 1 eV. Therefore, the recombination energy is somewhere between 4 and 7 eV, depending upon the ionic charge state. Although this figure is larger than the typical bond strength (3–4 eV), it is much smaller than the recombination energy of a free proton (13.6 eV), and causes only a moderate temperature increase after being distributed over a large number of degrees of freedom. For example, in a 3 kDa molecule, this increase is estimated to be between 50 and 100 K, which is far less than the typical value of 300 to 600 K for vibrational excitation (VE) techniques.⁵¹ This is consistent with the fact that labile groups are rarely lost in ECD.

Hydrogen atom capture model

Although the mechanism of c' , z' cleavage is not yet fully understood, it appears to be a very fast process. The original capture of the electron to a high Rydberg state is followed by either auto-emission of the captured electron back to the continuum, or “landing” on the cation. As discussed above, the charged site is the preferred landing site. Landing results mostly in charge neutralization which, in the case of protonation, creates an excess hydrogen atom. This atom carries away some recombination energy in the form of kinetic energy. For example, neutralization of protonated lysine gives a hypervalent species that rapidly decays by H' emission



or by ammonia ejection

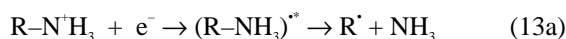

In gas-phase peptides, protons are primarily located at the side chains of the basic residues Arg, Lys and His. If these side chains were isolated, ECD would give only losses of small groups [e.g. NH_3 as in Reaction 13(a)]. Since the charges are shared (solvated) with the backbone functionalities, the hot hydrogen atom becomes mobile along the backbone. Exploring the vicinity of the solvation site, it can be captured by a group with a sufficient affinity, such as carbonyl

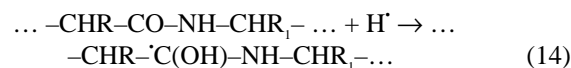

or disulfide

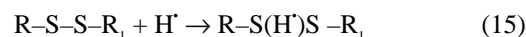

The exothermicity of the charge neutralization and the H' capture is used for bond cleavage, initiated by the presence of a radical site

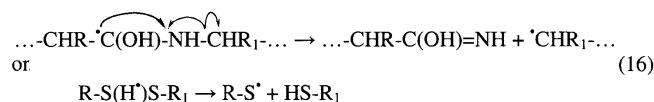

The even-electron product in Reaction 16 is the c' fragment, while the radical species is the z' fragment. This homolytic amine bond cleavage is in stark contrast with the heterolytic amide bond (peptide bond) b , y fragmentation in VE.

The proton affinity of the disulfide group is approximately 1 eV lower than that of the carbonyl group and its protonation is unlikely.¹³ Therefore, if electron capture occurs only at the protonation sites and if cleavage only occurs nearby, then the observed preferential S–S bond cleavage is difficult to explain. This problem is solved by acknowledging the critical role of the intermediate species, hot hydrogen atoms. The model predicts that other groups with high affinity towards H' , for example, the indole group of the tryptophan side chain, will also be reactive in ECD.¹³ Indeed, the ion peaks corresponding to backbone cleavage around tryptophan residues are often prominent in ECD spectra.¹²

There are also observations that are difficult to explain consistently within the hot hydrogen atom model. Porter has measured the energy of the H' , ejected upon neutralization of the NH_4^+ ions, to be ≈ 0.2 eV,²⁸ which is just a small fraction of the energy released in this > 4 eV exothermic recombination process. At the same time, Demirev has demonstrated that ≤ 1 eV hydrogen atoms neither attach to ground-state protonated peptides nor fragment them and only produce exchange with intramolecular hydrogen atoms.³⁹ In another study, collisional excitation of the disulfide-containing molecules with an attached hydrogen atom did not produce S–S bond dissociation as has been expected from the hot hydrogen mechanism.⁵² More experimental and theoretical investigations are needed to explain these inconsistencies.

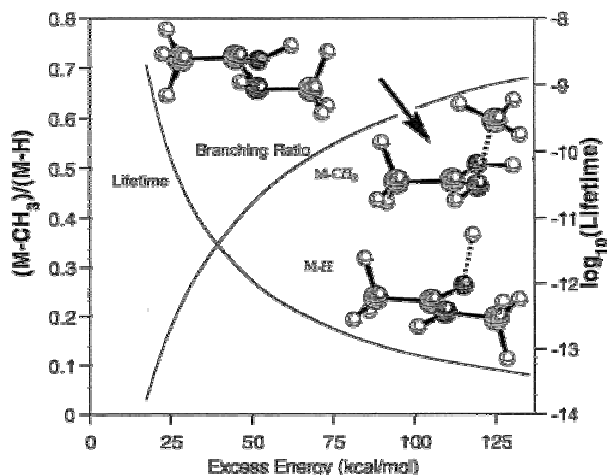

Figure 7. Branching ratios for the competitive losses of hydroxyl H and N-substituted CH_3 from $\text{CH}_3\text{-C(OH)-NH-CH}_3$ from RRKM calculations using B3LYP/6-31G(d) geometries and frequencies. Reproduced with permission from Reference 13.

Non-ergodic cleavage

Non-ergodic fragmentation is the most intriguing and the most debated feature of ECD. The RRKM theory that explicitly assumes IVR prior to bond dissociation (ergodic behavior) has been very successful in accounting for the observed cleavage rates in VE techniques. However, RRKM modeling made by Carpenter could account for the observed N-C_α cleavage only when the whole recombination energy is released in a small molecular region containing just a few atoms, i.e. without energy redistribution over the whole molecule (Figure 7).¹³ At lower energy excess, hydrogen loss prevailed. Such a loss from the reduced species $[\text{M} + n\text{H}]^{(n-1)+}$ is indeed observed in ECD but it is only prominent for ≤ 1 kDa molecules and species with low H⁺ affinities. The N-C_α cleavage occurring in the simulations was on a time scale $< 10^{-12}$ s, i.e. faster than IVR that requires at least

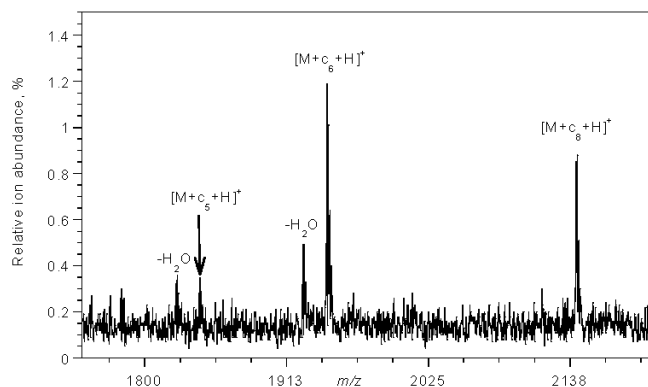

Figure 8. ECD of $(\text{M} + 3\text{H})^{3+}$ ions of a non-specific dimer of a 13-residue peptide TTTDSTTPAPTTK. Reproduced with permission from Reference 8.

10^{-11} s. In other words, the RRKM modeling yielded essentially non-RRKM results, consistent with a non-ergodic ECD mechanism.

The experimental evidence is strongly in favor of the non-ergodic mechanism. As follows from Equation 12, the recombination energy does not depend upon the molecular mass. Still, ECD can be efficient for large (> 10 kDa) molecular ions despite the large number of degrees of freedom. But perhaps the best experimental support for non-ergodicity is provided by ECD of supramolecular aggregates, the most labile species observed in biological mass spectrometry.⁸ VE techniques produce separation of the cluster constituents, and, only occasionally, covalent bond fragmentation, mostly trivial ones. With the non-ergodic ECD cleavage, it was expected that fragmentation of a strong covalent bond without dissociation of the weakly-bound constituents would be achieved. The successful result of such an experiment is shown in Figure 8. Electrospray ionization (ESI)-generated tri-cations of a non-specific head-to-toe dimer of a 13-residue peptide produced three weakly-bound fragments of the composition $[\text{M} + c'_x + \text{H}]^+$, $x = 5, 6, 8$, by electron capture.⁸ The c'_7 fragment was absent because of the proline residue at the eighth position. CAD of the $[\text{M} + c'_6 + \text{H}]^+$ ion produced $[\text{M} + \text{H}]^+$ ions, as was expected for non-covalent bonding. Other examples of covalent bond cleavage in the presence of non-covalent links include ECD of the 2+ ion of the complex between the antibiotics vancomycin and eremomycin (modified Cl-containing glycopeptides) with the tri-peptide diacetyl L-Lys-D-Ala-D-Ala.⁵³

In the sequencing of proteins > 20 kDa, non-covalent intramolecular bonding that survives ECD is an obstacle to obtaining abundant backbone fragmentation, since the ECD mass spectrum is dominated by what appear to be intact reduced species. CAD of the reduced species of the small protein ubiquitin (8.6 kDa) in lower charge states (7+ and 8+) produced complementary c' and z' species,⁴⁷ consistent with immediate N-C_α cleavage upon electron capture but without separation of the fragments before CAD. Therefore, for ECD of larger proteins McLafferty *et al.* used “in-beam” ECD or “activated-ion” ECD (AI ECD), where the precursor ions were vibrationally excited before ECD in order to break the non-covalent bonding.⁵⁴ The same group studied the kinetics of folding and unfolding of multiply-charged proteins in the gas phase, using ECD fragments as indicators of the absence of weak intramolecular bonding.⁵⁵

N-C_α bond cleavage

What makes the usually strong N-C_α bonds break in ECD? Bond loosening (bond length increase) has been suggested as a general empirical rule explaining fragmentation of, for example, organic radical cations produced by electron ionization (EI) and peptide bond cleavage in collisional activation.⁵⁶ However, *ab initio* B3LYP/cc-pVTZ calculations on the model structure $\text{CH}_3\text{-C(O)-NH-CH}_3$ showed that the N-C_α bond length remained the same upon neutralization of protonated backbone carbonyl or upon placing an extra elec-

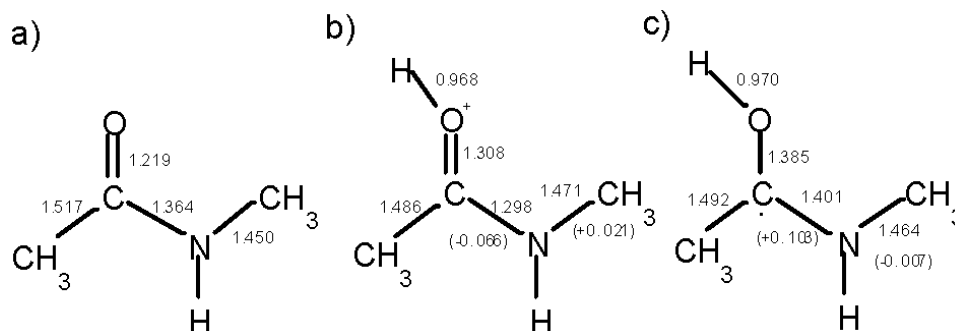

Figure 9. B3LYP/cc-pVTZ calculations of bond lengths.

tron on the carbonyl oxygen atom (Figure 9). On the other hand, the endothermicity of $N-C_\alpha$ bond cleavage in the radical $CH_3C'(OH)NHCH_3$ is just 19 kJ mol^{-1} , lower than for any other bond in that species. Bond weakening without bond length increase had been puzzling, until it was discovered that the $N-C_\alpha$ bond dissociation is associated with an unusually large activation barrier.

H⁺ capture on nitrogen atom?

We have attempted to draw a picture of the ECD process using a model system, viz. a complex between *N*-methylacetamide and protonated methylamine (Figure 10) chosen to represent a protonated side chain of the lysine residue solvated on the backbone carbonyl group. The ‘‘snapshots’’ of the energy surface have been taken with B3LYP/cc-pVTZ calculations.

The strength of the proton bonding was found to be 135 kJ mol^{-1} . Neutralization of the charged site is only 254 kJ mol^{-1} exothermic, which is explained by the high proton affinity of the neutral complex (neutralization of

$CH_3NH_3^+$ alone releases 363 kJ mol^{-1}). The fate of this energy can be different. In DR of small organic cations, a rather small fraction of the recombination energy is released as the kinetic energy of fragments, whereas the rest goes to electronic excitation that can convert into vibrational excitation (VE). Because of the weak coupling, the major fraction of the vibrational energy is likely to remain in 1NH_3CH_3 prior to its fragmentation. Statistical distribution over vibrational modes gives 13 kJ mol^{-1} per mode on average. The H^+ loss from free $CH_3NH_3^+$ is exothermic by 16 kJ mol^{-1} , with a barrier for dissociation of only 13 kJ mol^{-1} . The height of the free energy barrier at 298 K is very small ($\approx 1 \text{ kJ mol}^{-1}$) due to the large entropy increase. Therefore, hydrogen atom ejection from 1NH_3CH_3 can occur very rapidly, likely within one vibration. Momentum conservation requires dissociation of the complex simultaneously with the H^+ transfer.

Since one hydrogen atom at the charged amino group is likely to be shared with the carbonyl oxygen atom, that H^+ atom will be transferred to the oxygen atom. Such a transfer from $CH_3NH_3^+$ is found to proceed without a barrier. Addition of a hydrogen atom to the carbonyl oxygen is exother-

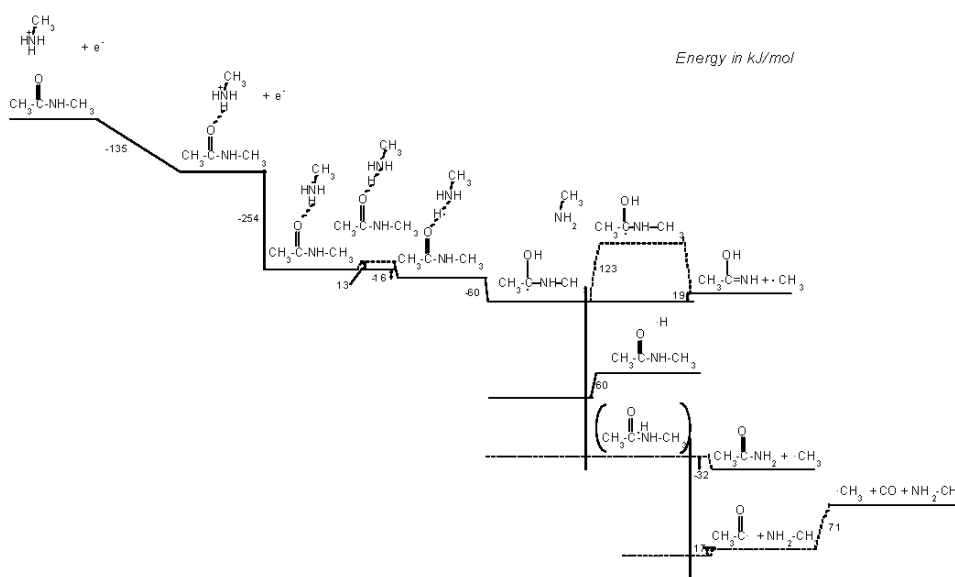

Figure 10. Energy levels of the optimized structures assumed to be involved in the hot hydrogen atom mechanism.

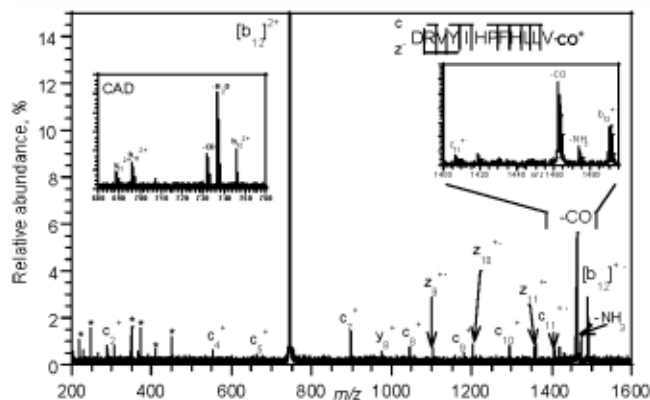

Figure 11. ECD mass spectrum of b_{12}^{2+} ion from renin substrate. Reproduced with permission from Reference 58.

precursor ion is reduced by two thirds, in reasonable agreement with experimental observations.

Another explanation of the limited ECD efficiency is that the extensive backbone cleavage results in a large number of low-abundance fragment ion signals, which can be lost in noise. Integration of multiple scans brings up the low-abundance fragments as the signal-to-noise ratio improves at the expense of longer data accumulation times.⁸ Until recently, the seconds-long irradiation with low-energy electrons has been the longest part of the experimental sequence of events (“script”). With the new electron sources based on indirectly-heated dispenser cathodes instead of the heated filament, the shortest ECD time has decreased to 1 ms, resulting in scripts as short as 250 ms, with an overall accumulation rate of three spectra per second.⁸

ECD of unusual species

ECD of multiply-charged b and y' fragments is the essential step in deriving structural information by multiple-stage tandem mass spectrometry (MS^n). Since y' ions are just shorter peptides, their ECD spectra are identical to those of the latter.⁴⁷ ECD of the less-stable b^{2+} ions sometimes shows an abundant loss of 28 Da (CO) from the C-terminus (Figure 11), which is an indication of the presence of the acylium form.⁵⁸ Neutralization of the acylium ion does not involve hydrogen rearrangement and the c'_{n-1} ion from b^{2+} is usually a radical species, c_{n-1}^{\cdot} , consistent with the hot H^{\cdot} mechanism.

ECD of peptide nucleic acids (PNAs) gave an important hint in understanding the role of backbone charge solvation in c' , z' cleavage.⁵⁹ PNAs combine, essentially, a polypeptide backbone with nucleobase side chains. Although PNAs readily produce multiply-charged ions, their ECD spectra are much less informative than those of polypeptides, being dominated by trivial base losses (Figure 12). One of the possible reasons is that the side chains are too bulky so that the charge sharing with the backbone that is typical for peptides is rare for PNAs.

ECD of polyglycol (PG) cations is discussed by McLafferty *et al.* in References 60 and 61. In sharp contrast

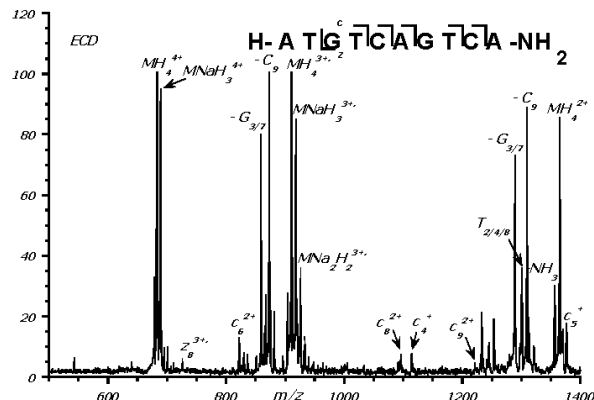

Figure 12. ECD mass spectrum of 4+ ions of a PNA. Reproduced with permission from Reference 59.

to MS/MS of polypeptides, ECD of PGs produced the same type of ions as CAD. ECD of $(PG_k + nH)^{n+}$ often gave distributions of the fragment intensities that resembled CAD of both $(PG_k + nH)^{n+}$ and $(PG_k + (n-1)H)^{(n-1)+}$ ions, showing $(n-2)$ distinct groups of peaks (Figure 13).⁶¹ This does not exclude the vibrational excitation following the emission of the hot hydrogen atom:

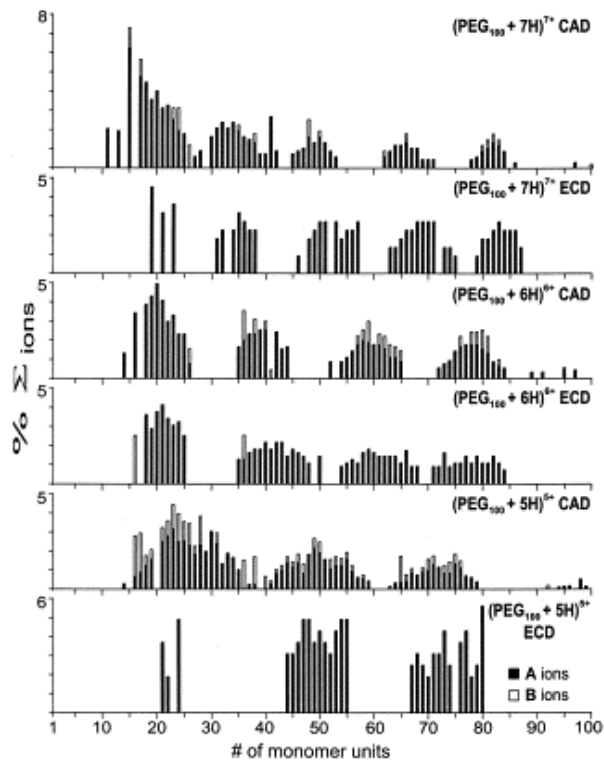
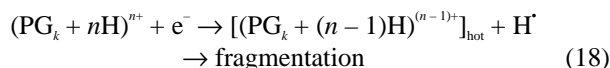

Figure 13. Ion abundances in CAD and ECD spectra of polyethylene glycol ions $(PEG_{100} + nH)^{n+}$, $n = 7, 6,$ and 5 . Reproduced with permission from Reference 61.

At the same time, the difference between the maxima of the fragment groups from $(PG_k + nH)^{n+}$ ions⁶¹ approached $k/(n-1)$ for both CAD and ECD (Figure 13). That means that the distribution of the remaining charges was largely preserved in ECD, consistent with cleavage prior to charge randomization. As another sign of a rapid ECD cleavage, water molecule losses from fragments that are abundant in CAD have not been detected.⁶⁰

Another finding in these studies was that ECD of $(PG + 2Na)^{2+}$ produces significantly less fragmentation than ECD of $(PG + 2H)^{2+}$, consistent with the much lower recombination energy of sodiated species compared with protonated species.⁶⁰ No incorporation of the neutralized Na atom into the product was detected. The same result was produced by ECD of $(PG + 2NH_4)^{2+}$ ions.

Conclusions

As with every novel phenomenon, ECD has a rich history that has roots in different research areas. To study this history is just as important for understanding the phenomenon as is obtaining new experimental data. Despite the clues and hints spread among the scientific literature, non-ergodic ECD came largely as a surprise for the community (with one notable exception²⁹). Thus, it is more important to appreciate these clues with hindsight; their very presence testifies to the harmony in nature and to the unity of the underlying phenomena.

By any standards, ECD is still in an early stage of its development, and the debates on its mechanism will be heated for some time to come. However, new techniques that go beyond ECD have already appeared; for example, electronic excitation dissociation (EED⁶²) for singly-charged ions and electron detachment dissociation (EDD⁶³) for multiply-deprotonated ions. With the appearance of these new excitation techniques, it is clear that ECD is just the tip of an iceberg of still largely unexplored ion–electron reactions. New and exciting findings will surely follow.

Acknowledgements

This work was supported by the Danish National Research Councils, grants STVF-0001242, SNF-51-00-0358 and STVF-26-01-0058, and INTAS grant 99-478.

References

1. R.A. Zubarev, N.L. Kelleher and F.W. McLafferty, *J. Am. Chem. Soc.* **120**, 3265 (1998).
2. N.A. Kruger, R.A. Zubarev, D.M. Horn and F.W. McLafferty, *Int. J. Mass Spectrom. Ion Processes* **185–187**, 787 (1999).
3. D.M. Horn, R.A. Zubarev and F.W. McLafferty, *Proc. Natl. Acad. Sci. USA* **97**, 10313 (2000).
4. N.L. Kelleher, R.A. Zubarev, K. Bush, B. Furie, B.C. Furie, F.W. McLafferty and C.T. Walsh, *Anal. Chem.* **71**, 4250 (1999).
5. E. Mirgorodskaya, P. Roepstorff and R.A. Zubarev, *Anal. Chem.* **71**, 4431 (1999).
6. S.D.-H. Shi, M.E. Hemling, S.A. Carr, D.M. Horn, I. Lindh and F.W. McLafferty, *Anal. Chem.* **73**, 19 (2000).
7. A. Stensballe, O.N. Jensen, J.V. Olsen, K.F. Haselmann and R.A. Zubarev, *Rapid Commun. Mass Spectrom.* **14**, 1793 (2000).
8. K.F. Haselmann, B.A. Budnik, J.V. Olsen, M.L. Nielsen, C.A. Reis, H. Clausen, A.H. Johnson and R.A. Zubarev, *Anal. Chem.* **73**, 2998 (2001).
9. O. Bulet, C.Y. Yang and S.J. Gaskell, *J. Am. Soc. Mass Spectrom.* **3**, 337 (1992).
10. F. Kjeldsen, B.A. Budnik, K.F. Haselmann, F. Jensen and R.A. Zubarev, *Chem. Phys. Lett.* **356**, 201 (2002).
11. W. Yu, J.E. Vath, M.C. Huberty and S.A. Martin, *Anal. Chem.* **65**, 3015 (1993).
12. N.A. Kruger, R.A. Zubarev, B.K. Carpenter, N.L. Kelleher, D.M. Horn and F.W. McLafferty, *Int. J. Mass Spectrom. Ion Processes* **182/183**, 1 (1999).
13. R.A. Zubarev, N.A. Kruger, E.K. Fridriksson, M.A. Lewis, D.M. Horn, B.K. Carpenter and F.W. McLafferty, *J. Am. Chem. Soc.* **121**, 2857 (1999).
14. J. Kaplan, *Phys. Rev.* **38**, 1048 (1931).
15. D. Kella, L. Vejby-Christiansen, P.J. Johnson, H.B. Pedersen and L.H. Andersen, *Science* **276**, 1530 (1997).
16. L.H. Andersen, O. Heber, D. Kella, H.B. Pedersen, L. Vejby-Christiansen and D. Zajfman, *Phys. Rev. Lett.* **77**, 4891 (1996).
17. J.B.A. Mitchell and C. Rebrion-Rowe, *Int. Rev. Phys. Chem.* **16**, 201 (1997).
18. D.R. Bates, *Phys. Rev.* **77**, 718 (1950).
19. J.N. Bradsley, *J. Phys. B* **1**, 365 (1968).
20. T.M. Leu, M.A. Biondi and R. Johnson, *Phys. Rev. A* **7**, 292 (1973).
21. J.N. Bradsley and M.A. Biondi, in *Advances in Atomic and Molecular Physics*, Ed by D.R. Bates. Academic Press, New York, USA, pp. 1–57 (1970).
22. D.R. Bates, *J. Phys. B* **24**, 703 (1991).
23. D.C. Walker, in *Radiation Chemistry*, Ed by E.J. Hart. ACS Adv. Chem., Vol. 81, pp. 49–64 (1968).
24. J. Kopoldova, in *Radiation Chemistry*, Ed by E.J. Hart. ACS Adv. Chem., Vol. 81, pp. 472–479 (1968).
25. G.E. Adams, in *Advances in Radiation Chemistry*, Ed by M. Burton and J.L. Magee. Wiley, New York, USA, Vol. 3, pp. 125–208 (1972).
26. Y. Gauduel, H. Gelabert and J. Guillaud, *J. Am. Chem. Soc.* **122**, 5082 (2000).
27. C. Wesdemiotis and F.W. McLafferty, *Chem. Rev.* **87**, 495 (1987).
28. G.I. Gellene and R.F. Porter, *J. Phys. Chem.* **88**, 6680 (1984).

29. F.W. McLafferty, in *Mass Spectrometry in the Analysis of Large Molecules*, Ed by C.J. McNeal. John Wiley, New York, USA, pp. 107–120 (1986).
30. R.A. Chorus, I. Vidavsky and F.W. McLafferty, *Org. Mass Spectrom.* **28**, 1016 (1993).
31. K. Vékey, A.G. Brenton and J.H. Beynon, *J. Phys. Chem.* **90**, 3569 (1986).
32. J.M. Curtis, K. Vékey, A.G. Brenton and J.H. Beynon, *Org. Mass Spectrom.* **22**, 289 (1987).
33. R.R. Ogorzalek Loo, H.R. Udseth and R.D. Smith, *J. Am. Soc. Mass Spectrom.* **3**, 695 (1992).
34. J.L. Stephenson, G.J. Van Berkel and S.A. McLuckey, *J. Am. Soc. Mass Spectrom.* **8**, 637 (1997).
35. M. Scalf, M.S. Westphall, J. Krause, S.L. Kaufman and L.M. Smith, *Science* **283**, 194 (1999).
36. R.B. Cody and B.S. Freiser, *Anal. Chem.* **51**, 547 (1979).
37. B.-H. Wang and F.W. McLafferty, *Org. Mass Spectrom.* **25**, 554 (1990).
38. M. Sablier, H. Mestdagh, L. Poisson, N. Leymarie and C. Rolando, *J. Am. Soc. Mass Spectrom.* **8**, 587 (1997).
39. P.A. Demirev, *Rapid Commun. Mass Spectrom.* **14**, 777 (2000).
40. M.L. Nielsen, B.A. Budnik and R.A. Zubarev, unpublished results.
41. Z. Guan, N.L. Kelleher, P.B. O'Connor, D.J. Aaserud, D.P. Little and F.W. McLafferty, *Int. J. Mass Spectrom. Ion Processes* **157/158**, 357 (1996).
42. J. Axelsson, M. Palmblad, K. Håkansson and P. Håkansson, *Rapid Commun. Mass Spectrom.* **13**, 474 (1999).
43. R.S. Brown and J.J. Lennon, *Anal. Chem.* **67**, 3990 (1995).
44. M. Takayama and A. Tsugita, *Electrophoresis* **21**, 1670 (2000).
45. P.J. Calba, J.F. Muller and M. Inouye, *Rapid Commun. Mass Spectrom.* **12**, 1727 (1998).
46. A.P. Quist, T. Huth-Fehre and B.U.R. Sundqvist, *Rapid Commun. Mass Spectrom.* **8**, 149 (1994).
47. R.A. Zubarev, D. Horn, E.K. Fridriksson, N.L. Kelleher, N.A. Kruger, M.A. Lewis, B.K. Carpenter and F.W. McLafferty, *Anal. Chem.* **72**, 563 (2000).
48. B.A. Budnik, K.H. Haselmann, M.L. Nielsen, J.V. Olsen and R.A. Zubarev, *Abstracts of the 49th meeting of the American Society for Mass Spectrometry*, Chicago, IL, USA June (2001).
49. R.A. Zubarev, in *Dissociative Recombination, Theory, Experiments and Applications IV*, Ed by M. Larsson, J.B.A. Mitchell and I.F. Schneider. World Scientific, Singapore, pp. 214–217 (2000).
50. I.A. Kaltashov, D. Fabris and C.C. Fenselau, *J. Phys. Chem.* **99**, 10046 (1995).
51. P.D. Schnier, J.C. Jurchen and E.R. Williams, *J. Phys. Chem. B* **103**, 737 (1999).
52. F. Turecek, M. Polasek, A.J. Frank and M. Sadilek, *J. Am. Chem. Soc.* **122**, 2361 (2000).
53. T.J.D. Jørgensen, K.F. Haselmann and R.A. Zubarev, unpublished results.
54. D.M. Horn, Y. Ge and F.W. McLafferty, *Anal. Chem.* **72**, 4778 (2000).
55. D.M. Horn, K. Breuker, A.J. Frank and F.W. McLafferty, *J. Am. Chem. Soc.* **123**, 9792 (2001).
56. I. Mayer and Á. Gömöry, *J. Mol. Struct.* **311**, 331 (1994).
57. H.J. Cooper, R.R. Hudgins, K. Håkansson and A.G. Marshall, *J. Am. Soc. Mass Spectrom.* **13**, 241 (2002).
58. K.F. Haselmann, B.A. Budnik and R.A. Zubarev, *Rapid Commun. Mass Spectrom.* **14**, 2242 (2000).
59. J.V. Olsen, K.F. Haselmann, M.L. Nielsen, B.A. Budnik, P.E. Nielsen and R.A. Zubarev, *Rapid Commun. Mass Spectrom.* **15**, 969 (2001).
60. B.A. Cerda, D.M. Horn, K. Breuker, B.K. Carpenter and F.W. McLafferty, *Eur. Mass Spectrom.* **5**, 335 (1999).
61. B.A. Cerda, K. Breuker, D.M. Horn and F.W. McLafferty, *J. Am. Soc. Mass Spectrom.* **12**, 565 (2001).
62. M.L. Nielsen, B.A. Budnik, K.F. Haselmann, J.V. Olsen and R.A. Zubarev, *Chem. Phys. Lett.* **330**, 558 (2000).
63. B.A. Budnik, K.F. Haselmann and R.A. Zubarev, *Chem. Phys. Lett.* **342**, 299 (2001).

Received: 27 August 2001

Revised: 3 July 2001

Accepted: 5 July 2002

Web Publication: 25 October 2002