

# **HIGH SPEED AND LOW WEIGHT MICRO ACTUATORS FOR HIGH PRECISION ASSEMBLY APPLICATIONS**

*Micro Actuators with the Micro Harmonic Drive*

Dr. Reinhard Degen<sup>1</sup> and Dr. Rolf Slatter<sup>2</sup>

<sup>1</sup>Managing director of Micromotion GmbH, An der Fahrt 13, 55124 Mainz, Germany;

<sup>2</sup>Managing director of Micromotion GmbH, An der Fahrt 13, 55124 Mainz, Germany

**Abstract:** The trend to miniaturization cannot be overseen. The use of very small electronic and electro-optical components in a variety of consumer and investment goods is leading to an increasing demand for small-scale servo actuators for micro assembly applications in production equipment. The previous generation of micro gears and micro actuators was not suited to this type of application, because of unacceptable accuracy.

The Micro Harmonic Drive<sup>®</sup> gear was introduced into the market in 2001 as the world's smallest backlash-free micro gear. It is manufactured using a modified LIGA process, called Direct-LIG. This allows the cost-effective production of extremely precise metallic gear components. In the meantime this gear has been implemented in a range of miniaturized servo actuators, which provide zero backlash, excellent repeatability and long operating life.

In addition to the above-mentioned advantages this innovative product also features a central hollow shaft. This allows the design engineer to pass an optical fiber, a laser beam or media such as fluids, compressed air or vacuum along the central axis of the servo actuator. This greatly simplifies the design of machines for micro assembly applications in the semi conductor, consumer goods, medical and optical fields. In this paper we will describe the development history, key features and applications of this innovative drive solution.

**Key words:** micro actuator; Micro Harmonic Drive<sup>®</sup>; assembly applications

## 1. INTRODUCTION

As soon as miniaturised systems and hybrid microsystems need to be manufactured in large series there is a requirement for automated assembly. For small scale products of this type the assembly process is often a major cost-driver, making up to 80% of total production costs [1]. Manual assembly is either too expensive, or does not achieve the required process stability. Automated micro assembly requires, in turn, specialised production equipment for handling miniature components. The assembly process typically requires movements in several degrees of freedom, which are enabled by power transmission components, such as motors, gears, ballscrews etc.

Until recently the physical size of these drive components was much larger than that of both the components to be handled and the necessary workspace, with the result that many machines and robots for micro assembly have dimensions far in excess of the necessary working area [1]. There is now a clear trend to equip physically smaller machines with micro drive systems. These machines have a smaller footprint and often higher assembly accuracy than the previous generation of machine.



Figure 1. Micro Harmonic Drive gearbox and actuator

Micro gear systems represent a key element in such micro drive systems. Only by using suitable micro gear systems is it possible to apply existing micro motors operating with speeds of up to 100.000 rpm at output torques in the range of some  $\mu\text{Nm}$  [2] in a wide field of different applications. To access new innovative fields of application in the range of micro drive systems Micromotion GmbH has developed a new generation of high precision and zero backlash micro gear system:

the Micro Harmonic Drive<sup>®</sup> (see Fig. 1).

## 2. THE MICRO HARMONIC DRIVE®

Micro-gears are not a particularly recent development and micro-spur gears or micro-planetary gears have been available in the market for a number of years. However, these products suffer from poor positioning accuracy and are therefore rarely used for positioning applications in machines. These previous solutions either have backlash, or only permit very light loads. What is needed are micro-gears that are not only very small in size, but also feature high repeatability, zero backlash, high reduction ratios and a low parts count. These requirements inspired the development of a new micro-gear, the Micro Harmonic Drive® gear [3] (Fig. 1).

This gear was developed by Micromotion GmbH in Mainz, in cooperation with the Institute for Microtechnology, also located in Mainz in Rhineland Palatinate, Germany. The Micro Harmonic Drive® gear is currently the world's smallest zero backlash gear and in combination with a specially developed motor from Maxon Motors, Switzerland, forms part of the world's smallest zero backlash positioning actuator (see Fig. 2).



Figure 2. World's smallest zero backlash actuator (diameter 8 mm, length 31 mm)

The principle of operation is similar to the conventional „macro-technological“ Harmonic Drive® gear [3], with the difference that the Wave Generator consists of a planetary gear stage. This enables very large reduction ratios in a small envelope. This is necessary, because most currently available micromotors only produce adequate torque at very high output speeds, typically more than 50.000 rpm, and a high reduction ratio then helps provide sufficient torque at an acceptable speed for practical motion control applications. The planet wheels are hollow and elastically deformable, with the result that backlash can be eliminated by gear pre-loading in the planetary gear stage.

The Micro Harmonic Drive<sup>®</sup> gear component set has an outer diameter of just 6 or 8 mm and an axial length of 1 mm. Fig. 3 shows a REM picture of the component set. It can provide reduction ratios between 160:1 and 1000:1. In order to allow easy integration in a wide range of different applications the component set is mounted inside a micro-gearbox of the MHD series, which is available in two sizes, either with an input shaft or for direct coupling to commonly available micro-motors. [4].

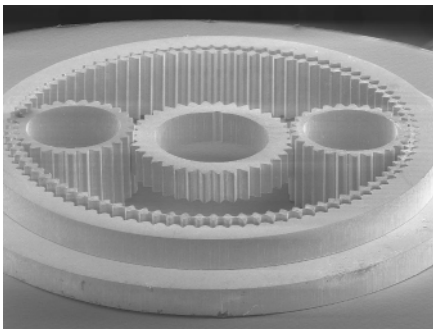

Figure 3. Micro Harmonic Drive<sup>®</sup> gear component set

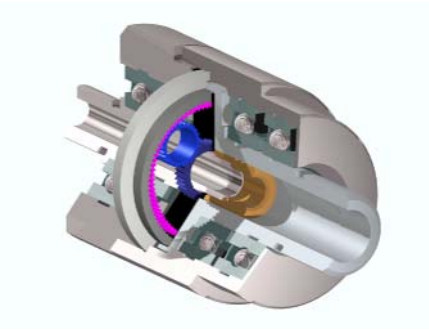

Figure 4. Micro Harmonic Drive<sup>®</sup> MHD gearbox

The gear component set is typically mounted inside a gearbox (see Fig. 4) with an output shaft mounted in pre-loaded ball bearings. The gearbox can either be directly coupled to a micro-motor, or can be provided with an input shaft, so that the motor can be mounted off-axis. A hollow shaft with an inner diameter of up to 1 mm passes along the central axis of rotation of the gear box.

This solution provides the machine designer with numerous advantages:

**a) *Miniature dimensions yet zero backlash***

The Harmonic Drive gear stage is backlash-free by nature and the elastically deformable planet wheels eliminate backlash in the planetary stage.

**b) *Excellent repeatability for precise positioning***

The zero backlash of the Micro Harmonic Drive<sup>®</sup> gear provides a repeatability in the range of a few seconds of arc. This enables positioning tasks to be carried out with sub- $\mu\text{m}$  accuracy.

**c) *High dynamic performance for fast indexing applications***

The high torque capacity and low moment of inertia enable extremely fast accelerations of up to  $550\,000\text{ rad/s}^2$  at the input shaft. This corresponds to an acceleration of the motor shaft from 0 to 100 000 rpm in 25 milliseconds. This, in turn, enables extremely fast angular movements e.g. a rotation of  $180^\circ$  in less than 80 milliseconds.

**d) *Very long operating life***

The MHD micro-gearboxes have an operating life of 2500 hours at rated operating conditions, that is, at rated input speed and rated output torque. This corresponds to many million operating cycles in practical applications and the operating life of the micro-gearbox is typically equivalent or longer than the expected operating life of the machine in which it is used. The “life-cycle-costs” are therefore considerably lower than for other solutions with a lower initial cost.

**e) *Very high reliability***

The MHD gearbox has a significantly higher MTBF (Mean Time Between Failure) rating than other microgears. This is mainly the result of the far lower number of parts, compared to other gears. A planetary microgear with a reduction ratio of 1000:1 typically has 25 individual gear wheels, whilst the comparable Micro Harmonic Drive<sup>®</sup> gear has just 6.

**f) *High efficiency to avoid power losses***

The Micro Harmonic Drive<sup>®</sup> gear has an efficiency of up to 82% at rated operating conditions. This is also significantly higher than for other micro-gears. The reason lies in the small number of tooth engagement areas. A planetary gear with ratio 1000:1 has 30 regions of tooth engagement, whilst the comparable Micro Harmonic Drive<sup>®</sup> has just 8.

**g) *Extremely flat design for compact gearbox dimensions***

The axial length of the MHD micro-gearbox is independent of the reduction ratio and is less than half the length of other micro-gearboxes for the same output torque and reduction ratio.

**h) *Low mass for applications in portable devices or in moving structures***

As can be seen from Table 1, the gearboxes weigh just a few grams. In practical applications this means that the moving masses in the machine can be minimised. This, in turn, can contribute to greater thermal stability and lower temperature rise, both of which are essential in high precision machines. Furthermore, this enables higher accelerations and/or smaller feed drives.

**i) *High reduction ratios for low-loss torque conversion and easy control***

The high reduction ratios greatly reduce the load moment of inertia reflected at the motor shaft. The result is that in most practical applications the motor is hardly influenced by the load inertia. In combination with the low input-side moment of inertia of the gear this has the effect that the control of the motor is almost independent of the load inertia over a very

large range of load inertias. This makes the control of the motor and setting-up of the control system very easy.

**j) Hollow shaft capability**

The optional hollow shaft can be used to pass laser beams, air / vacuum supply or optical fibres through the centre of the gear or actuator along the central axis of rotation. This can greatly simplify the design of machines where otherwise the laser beam or fibre would need to be diverted around the actuator.

**k) Robust, accurate output bearing arrangement**

The high load capacity of the output bearings (preloaded ball bearings in an O-configuration – see Fig. 2) mean that no additional support bearings are needed for the load in most applications. Furthermore, the accurate geometric tolerances (axial and radial run-out less than 5  $\mu\text{m}$ ) allow the attachment of load components e.g. mirrors, filters or lenses, directly to the output shaft.

**l) Applicable under extreme environmental conditions**

The use of high quality materials, such as stainless or high-alloy steels for the gearbox housing, input / output shafts and bearings, provides a high level of corrosion resistance, even for standard MHD micro-gearboxes. The Micro Harmonic Drive<sup>®</sup> gear, which is manufactured in a high strength Nickel-Iron alloy, can be sterilized and can be used over a very wide temperature range (-70° C - +150° C). It can also be applied in a vacuum [5], using grease, oil or dry lubrication, depending on the specific requirements of the application.

Table 1. Key performance data for MHD gearboxes

Gearbox size		MHD 8		MHD 10		
Reduction ratio		160	500	160	500	1000
Peak torque	[mNm]	14	20	24	36	48
Rated torque	[mNm]	7	10	12	18	24
Repeatability	[arcsec]	10	10	10	10	10
Outer diameter	[mm]	8	8	10	10	10
Weight (with input shaft)	[g]	3.5	3.5	5.7	5.7	5.7

This combination of features makes the Micro Harmonic Drive<sup>®</sup> gearbox very attractive for precise assembly applications. The high repeatability means that components can be orientated with very high accuracy, while the high dynamic performance means that assembly speed must not be sacrificed.

### 3. SPECIAL DEVELOPMENTS FOR MICROASSEMBLY APPLICATIONS

In this section two practical examples will be described, where Micro Harmonic Drive® gears are being used successfully in industrial micro assembly applications.

One of the main application areas for micro assembly equipment is in the electronics industry. The production process can be divided into a “front-end” process comprising the lithographic structuring of the silicon wafer and a “back-end” process, starting with the dicing of the wafer into individual chips and ending with the packaging of the electronic components, ready for subsequent final assembly.

So-called “die attach” machines are used in the assembly phase of the “back-end” process. Alphasem AG is one of the world’s leading manufacturers of “die attach” machines, which are used to assemble the chips in a protective package and connect the chip to the outside world. To do this the chips, which are today no larger than a piece of dust with dimensions of just 0.25 x 0.25 mm, must be orientated and positioned highly accurately. The new Easyline 8032 machine from Alphasem incorporates a new “Rotary Bond Tool” including a Micro Harmonic Drive® gearbox to realise simultaneously a high accuracy in the range of some milligrad, a short positioning time in the range of some milliseconds and an extreme low weight of about 30 grams. This space and mass optimized unit is used to position the chips with high accuracy at any desired angle of rotation.



Figure 5. Rotary bond tool with hollow shaft and optical sensor (Photo courtesy of Alphasem AG)

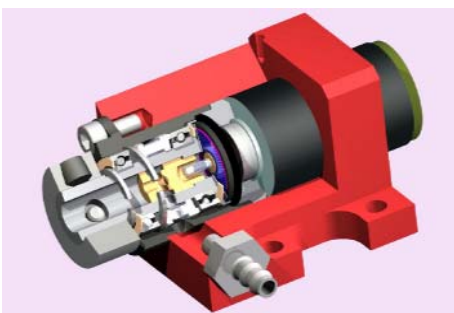

Figure 6. Rotary bond tool for high speed applications with a total weight of 22 grams and a repeatability of 0.005°

By this customer specific bond tool the motor is mounted off-axis, and so permit a hollow shaft to be passed through the centre of the reduction gear. This hollow shaft is used for a vacuum feedthrough, which is used to hold the chip in place during the positioning and assembly cycle. The hollow shaft also allows the use of an optical sensor, which looks through the centre of the reduction gear and output shaft to check that the chip has been correctly gripped. The figures 5 and 6 illustrate low weight Rotary Bond Tools for high speed applications.

At the heart of the Rotary Bond Tool is a Micro Harmonic Drive<sup>®</sup> gearbox in a custom-made design. The output shaft is mounted in pre-loaded ball bearings, which ensure that the radial and axial run-out of the output shaft is minimised. The output shaft of the gear box serves simultaneously as fitting for the customer and process specific tool. Due to the high transmission ratio and the zero backlash of Micro Harmonic Drive<sup>®</sup> gearbox is it possible to drive these units with simple and robust stepper motors. As section of such a customer specific Rotary Bond Tool from made by Micromotion GmbH is illustrated in Fig. 7. Due to the integration of several functionalities into the gear box it is possible to realise a very low weight and high dynamic system for high accuracy assembly applications.

The complete electromechanical sub-assembly is assembled and tested by Micromotion GmbH and allows chips to be placed with a repeatability of less than 1  $\mu\text{m}$  and high speed. In the field rotary bond tools of this design have achieved more than 30 million cycles without any loss of accuracy.



*Figure 7. Rotary bond tool section*



*Figure 8. 3-axis micro-manipulator*

The rotary bond tools described above allow highly accurate rotational positioning of a workpiece, but there are many micro assembly tasks requiring movements in three degrees of freedom. For this type of application Micromotion GmbH has developed a 3-axis micro-manipulator (see Fig. 8).



This compact device, with a diameter of only 36.2 mm and an axial length of less than 50 mm, features two linear and one rotational axis. The linear axes are driven using a cam arrangement, which move a small table in X- and Y-directions. The table carries the  $\theta$ -axis actuator, which drives the tool directly.

This design offers following advantages:

- Sub- $\mu\text{m}$  accuracy
- Easy controllability (stepping motors are used for all axes)
- Low mass (< 50g)
- Highly dynamic performance

Importantly, the long strokes for the linear axes, easy controllability and high stability under production conditions are superior in comparison to solutions based on piezo actuators.

Table 2. Key performance data for 3-axis micro-manipulator

		X-axis	Y-axis	Theta-axis
Stroke/angle		1 mm	1 mm	> 360°
Max. speed		2 mm/s	2 mm/s	100 rpm
Resolution	Full steps	< 0.3 $\mu\text{m}$	< 0.3 $\mu\text{m}$	0.0860°
	Microsteps	< 0.02 $\mu\text{m}$	< 0.02 $\mu\text{m}$	0.005°
Repeatability		< 0.3 $\mu\text{m}$	< 0.3 $\mu\text{m}$	0.010°
Forces / Torque		10 N	10 N	5 mNm

Typically this device is used for fine positioning and is mounted “piggy-back” on high-speed coarse positioning axes. Here the low weight is of particular importance. The trend to shorter assembly cycle times is leading to more dynamic primary positioning axes, typically featuring linear direct drive motors. If the mass of the “piggy-back” micro-manipulator can be minimised then the temperature increase of the linear motors is less for the same duty cycle. This can, in turn, avoid problems due to thermal instability of the machine, which can dramatically affect the positioning accuracy of the machine.

#### 4. OUTLOOK

Micromotion GmbH is continuing to develop the Micro Harmonic Drive<sup>®</sup> gear in order to further improve its performance. By optimising the tooth profile the peak torque can be increased further, which will enable even more dynamic positioning cycles and so reduce assembly cycle times even more.

Micromotion GmbH is also investigating the application of Micro Harmonic Drive® gears in a project in co-operation with the Institute for Machine Tools and Production Technology (IWF) at the Technical University of Braunschweig. In this project a Micro-SCARA robot with a parallel structure (Fig. 9) is being developed, which incorporates MHD gearboxes for the primary axes of the parallel arms.

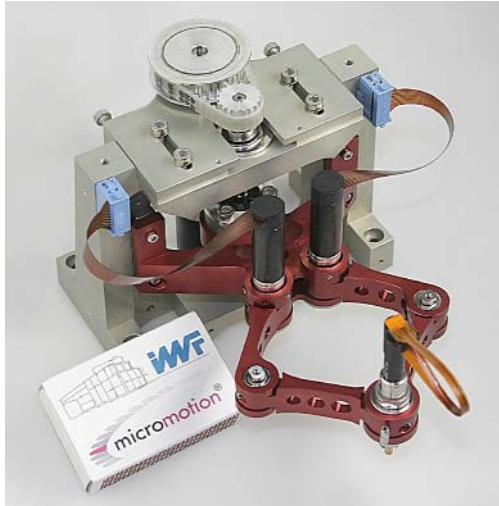

Figure 9. Micro-SCARA robot (Picture courtesy of IWF, TU Braunschweig)

This robot is designed to achieve sub- $\mu\text{m}$  accuracy and is intended to act as a technology demonstrator to open up new applications in the field of micro assembly.

## 5. REFERENCES

1. J. Hesselbach, A. Raatz: „mikroPRO –Untersuchung zum internationalen Stand der Mikroproduktionstechnik“, Vulkan Verlag, Essen, 2002
2. C. Thürigen, W. Ehrfeld, B. Hagemann, H. Lehr, F. Michel: Development, fabrication and testing of a multi-stage micro gear system. Proc. Of Tribology issues and opportunities in MEMS, pp. 397-402, Columbus (OH), November 1997, Kluwer Academic Publishers, 1998
3. R. Degen, R. Slatter: Hollow shaft micro servo actuators realized with the Micro Harmonic Drive®, Proceedings of Actuator 2002, Bremen
4. S. Kleen, W. Ehrfeld, F. Michel, M. Nienhaus, H.-D. Stölting: Ultraflache Motoren im Pfennigformat, F&M, Jahrg. 108, Heft 4, Carl Hanser Verlag, München, 2000
5. R. Slatter, R. Degen: Micro actuators for precise positioning applications in vacuum, Proceedings of Actuator 2004, Bremen