



Expert model for detection of epileptic activity in EEG signature

Tapan Gandhi^{a,b,*}, Bijay Ketan Panigrahi^c, Manvir Bhatia^d, Sneha Anand^{a,b}

^aBrain Dynamics and Cognitive Engineering Laboratory, Centre for Biomedical Engineering, Indian Institute of Technology, Delhi, India

^bBiomedical Engineering Unit, All India Institute of Medical Sciences, New Delhi, India

^cMachine Intelligence Research Laboratory, Department of Electrical Engineering, Indian Institute of Technology, Delhi, India

^dDepartment of Neurology, Sir Gangaram Hospital, New Delhi, India

ARTICLE INFO

Keywords:

Seizure
Discrete wavelet transform (DWT)
Approximate energy (EDN)
Probabilistic neural network (PNN)

ABSTRACT

Seizure detection and classification using signal processing methods has been an important issue of research for the last two decades. In the present study, a novel scheme was presented to detect epileptic seizure activity with very fast and high accuracy from background electroencephalogram (EEG) data recorded from epileptic and normal subjects. The proposed scheme is based on discrete wavelet transform (DWT) and energy estimation at each node of the decomposition tree followed by application of probabilistic neural network (PNN) for classification. Normal as well as epileptic EEG epochs were decomposed into approximation and details coefficients till the sixth-level using DWT. Approximate energy (EDA) values of the wavelet coefficients at all nodes of the down sampled tree were used as a feature vector to characterize the predictability of the epileptic activity within the records of EEG data. In order to demonstrate the classification accuracy of the proposed probabilistic neural network, tenfold cross-validation was implemented in the expert model. Clinical EEG data recorded from normal as well as epileptic subjects were used to test the performance of this new scheme. It was found that with the proposed scheme, the detection is 99.33% accurate with sensitivity and specificity as 99.6% and 99%, respectively. The proposed model can be widely used in developing countries where there is an acute shortage of trained neurologist.

© 2009 Elsevier Ltd. All rights reserved.

1. Introduction

Epilepsy is a chronic disorder characterized by recurrent seizures, which may vary from a brief lapse of attention or muscle jerks, to severe and prolonged convulsions. The seizures are caused by sudden, usually brief, excessive electrical discharges in a group of brain cells (neurons) (Cited in WHO, <http://www.who.int/topics/epilepsy/en/>). More than 1% (~50 million people) of the world's population is affected by epilepsy (Saraceno, Avanzini, & Lee, 2005). Eighty percent of the epileptic seizure activity can be controlled or can be treated effectively, if properly detected and diagnosed (Cited in WHO, <http://www.who.int/topics/epilepsy/en/>). The epileptic seizure activity is present on the background of EEG data, which is one of the famous electrophysiological techniques to see the uncontrolled firing of the neurons lead to change of awareness. EEG also contains very useful information relating to different physiological, psychological states of brain and thus is very effective tool to understand the complex dynamics of the brain. Since most cases EEG is

non-invasive, it can be recorded over a long time span to monitor the incidental disorder like epileptic seizure for presurgical evaluations to determine the epileptogenic foci of the brain. These EEG recordings are visually inspected by trained neurophysiologist for detecting epileptic seizures or other abnormalities present. This information is then used for proper clinical diagnosis and then accordingly various therapies, medications or surgical treatments are administered to the subjects. The visual scoring of the epileptic activity on EEG background is a very costly as well as time consuming task considering the greater numbers of patients admitted to the hospital. Moreover, due to the human error, leads to the improper diagnose of the disease causing fatal to human life. Thus a lot of effort has been devoted by biomedical engineers, researchers to develop an automated expert system for seizure detection which might help not only the physician to speed up the process with greater accuracy but also reduce the amount of data needs to be stored (Oeak, 2008a; Subasi, 2007; Tazel & OZbay, 2009).

Various techniques have been proposed in the literature (Oeak, 2008b; Iasemidis, Shiau, & Chaovalitwongsa, 2003; Khan & Gotman, 2003) for the detection of seizures in the EEG using correlation function, time domain analysis, frequency domain analysis, time–frequency domain analysis, artificial neural network based analysis, fuzzy logic based analysis are very few. In time domain based analysis (Hjorth, 1970; Liu, Hahn, Heldt, & Coen, 1992),

* Corresponding author. Address: Brain Dynamics and Cognitive Engineering Laboratory, Centre for Biomedical Engineering, Indian Institute of Technology, Delhi, India.

E-mail addresses: gandhitk@gmail.com, sneha@cbme.iitd.ac.in (T. Gandhi), bkpanigrahi@ee.iitd.ac.in (B.K. Panigrahi), manvirbhatia1@yahoo.com (M. Bhatia).

the autocorrelation of EEG have found out to provide the measure for rhythmicity. Most of the seizure detection schemes involve two stages. In the first stage, features are extracted from EEG signals from both epileptic and normal subjects and in the second stage the expert system is created by training the features obtained from the previous steps from each node of the decomposed tree. However, the EEG is non-stationary in nature, is most appropriate to use wavelet transform (time–frequency based) (Adeli, Zhou, & Dadmehr, 2003; Boashash, Mesbah, & Colditz, 2003; Goswami, 1999; Subasi, 2005) to get the time as well as the frequency information of the signal simultaneously. It also helps to accurately capture and localize transient features of the epileptic signal on the EEG background.

A variety of different artificial neural network (ANN) based approaches are reported in the literatures for epileptic seizure detection (Kurth, Gilliam, & Steinhoff, 2000; Kiyimik, Subasi, & Ozealik, 2004; Subasi, 2006). Models are built based on the most prominent features extracted from the training data set. This feature extraction process plays an important role for the classification performance of the NN.

By using nonlinear methods like correlation dimension (CD), Largest Lyapunov exponent (LLE) and approximate entropy (ApEn) quantify the degree of complexity in time series. Kannathal, Choo, Acharya, and Sadasivan (2005) tested the seizure detection performance of various entropy measures including ApEn using an artificial neuro-fuzzy inference system (ANFIS) classifier. Oeak (2008a) has also taken a bold step by implementing genetic algorithm for optimal feature extraction to classify epileptic seizures from normal EEG activity. However, the accuracy and speed of signal classification are better in the proposed approach.

In this paper features were extracted from both normal as well as epileptic EEG signals using wavelet transform (WT), which is one of the most promising methods to decompose the non-stationary EEG signal into various frequency bands (Mallat, 1998; Pavlopoulos, Istepanian, Kyriacou, & Koutsounis, 2000; Sanei & Chambers, 2007). The corresponding EEG epochs were decomposed into various frequency bands by using db4 mother wavelet up to sixth-level of the decomposition. Various features like energy, entropy and standard deviation were computed from these six decomposition levels to form the feature vector for classification purpose. These feature sets were used to train a probabilistic neural network (PNN) for the classification purpose. As a final step, 10-fold cross-validations are employed to demonstrate the accuracy of classification. Clinical EEG recorded from normal as well as epileptic subjects were used to test the validity of the proposed scheme.

2. Material and methods

2.1. Clinical data selection

The EEG data used for this study was recorded on a Grass Telefactor EEG Twin3 machine available at Sir Ganga Ram Hospital, New Delhi. EEG recordings of a number of epileptic subjects were taken from the hospital's epileptic (both ictal and interictal) database randomly. All the EEG signals were acquired using 16 gold electrodes placed on the scalp according to the international 10–20 system of electrode placement as shown in Fig. 1. Two sets of data, containing 1200 epochs of duration 10 s each were selected for the study. The first sets of data were epileptic signals (of all types). The second set was background activity of the same person, seizure free and normal. The signals used for this study were acquired with the sampling frequency of 400 Hz. All the data were selected from the large epileptic database of the hospital, under the supervision of experienced neurologists. The normal as well as the epileptic data from occipito-temporal region of a subject were plotted and shown in Fig. 2.

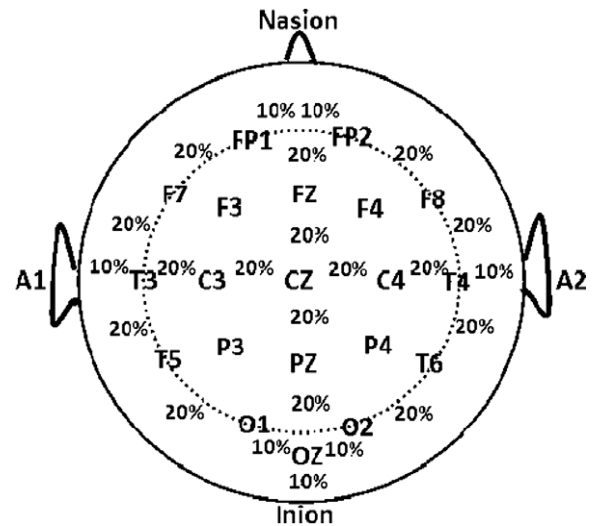

Fig. 1. 10/20 International system of electrode placement.

2.2. Discrete wavelet transform (DWT) for signal analysis

Wavelet transform (WT) was introduced by Morlet at the beginning of 1985 and has attracted much interest in the fields of signal and image processing. Applications of DWT in biomedical signal processing are reported for

- Extraction of features from various Biosignals.
- To localize the particular frequency component with respect to time.
- Modeling of expert system in wavelet domain.

In this section an introduction to wavelet transform is presented. The WT was developed as an alternative to the Short Time Fourier Transform (STFT) to overcome problems related to its frequency and time resolution properties. More specifically, unlike the STFT that provides uniform time resolution for all frequencies, the DWT provides high time resolution and low frequency resolution for high frequencies and high frequency resolution and low time resolution for low frequencies. The DWT is a special case of the WT that provides a compact representation of a signal in time and frequency that can be computed efficiently. The DWT is calculated based on two fundamental equations: the scaling function ϕ , and the wavelet function $\psi(t)$, where

$$\phi(t) = \sqrt{2} \sum_k h_k \phi(2t - k), \quad (1)$$

$$\psi(t) = \sqrt{2} \sum_k g_k \phi(2t - k). \quad (2)$$

These functions are two-scale difference equations based on a chosen scaling function (mother wavelet), with properties that satisfy the following conditions

$$\sum_{k=1}^N h_k = \sqrt{2} \quad (3)$$

$$\sum_{k=1}^N h_k h_{k+2l} = 1, \quad \text{if } l = 0, \\ \text{if } l \in \mathbb{Z}, l \neq 0. \quad (4)$$

The discrete sequences h_k and g_k represent discrete filters that solve each equation, where $g_k = (-1)^k h_{N-1-k}$. The scaling and wavelet functions are the prototype of a class of orthonormal basis functions of the form

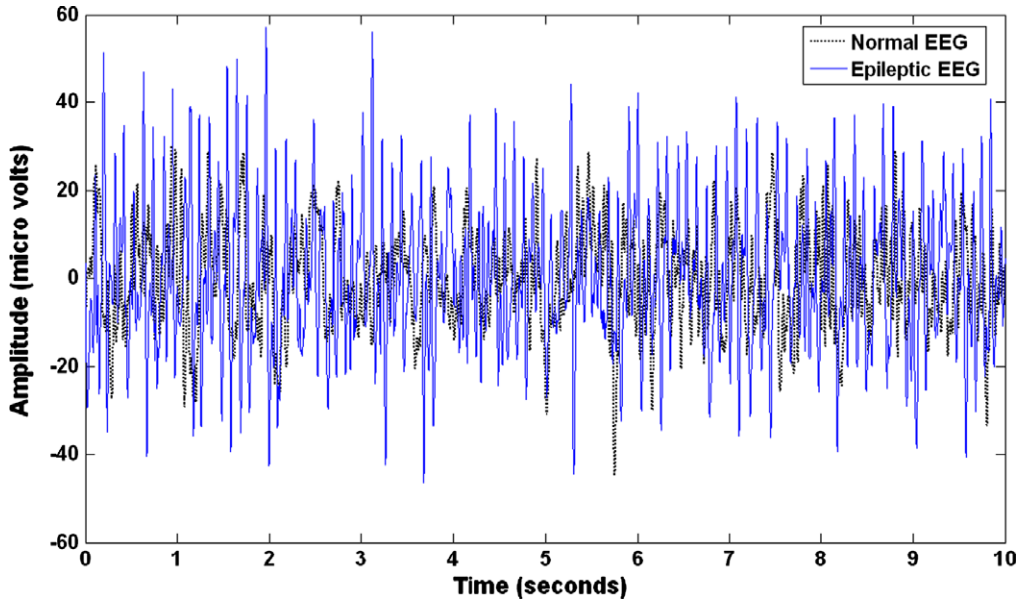

Fig. 2. Time domain representation of Normal and Epileptic Signal acquired from occipito-temporal region.

$$\phi_{j,k}(t) = 2^{\frac{j}{2}}\phi(2^j t - k); \quad j, k \in Z, \quad (5)$$

$$\psi_{j,k}(t) = 2^{\frac{j}{2}}\psi(2^j t - k); \quad j, k \in Z, \quad (6)$$

where the parameter j controls the dilation or compression of the function in time scale and amplitude. The parameter k controls the translation of the function in time. Z is the set of integers.

Once a wavelet system is created, it can be used to expand a function $f(t)$ in terms of the basis functions

$$f(t) = \sum_{l \in Z} c(l)\phi_l(t) + \sum_{j=0}^{J-1} \sum_{k=0}^{\infty} d(j,k)\psi_{j,k}(t), \quad (7)$$

where the coefficients $c(l)$ and $d(j, k)$ are calculated by inner product as

$$c(l) = \langle \phi_l | f \rangle = \int f(t)\phi_l(t)dt, \quad (8)$$

$$d(j, k) = \langle \psi_{j,k} | f \rangle = \int f(t)\psi_{j,k}(t)dt. \quad (9)$$

The expansion coefficients $c(l)$ represent the approximation of the original signal $f(t)$ with a resolution of one point per every 2^l points of the original signal. The expansion coefficients $d(j, k)$ represent details of the original signal at different levels of resolution. $c(l)$ and $d(j, k)$ terms can be calculated by direct convolution of $f(t)$ samples with the coefficients h_k and g_k , which are unique to the specific mother wavelet chosen.

The WT can be implemented with a specially designed pair of FIR filters called a quadrature mirror filters (QMFs) pair. QMFs

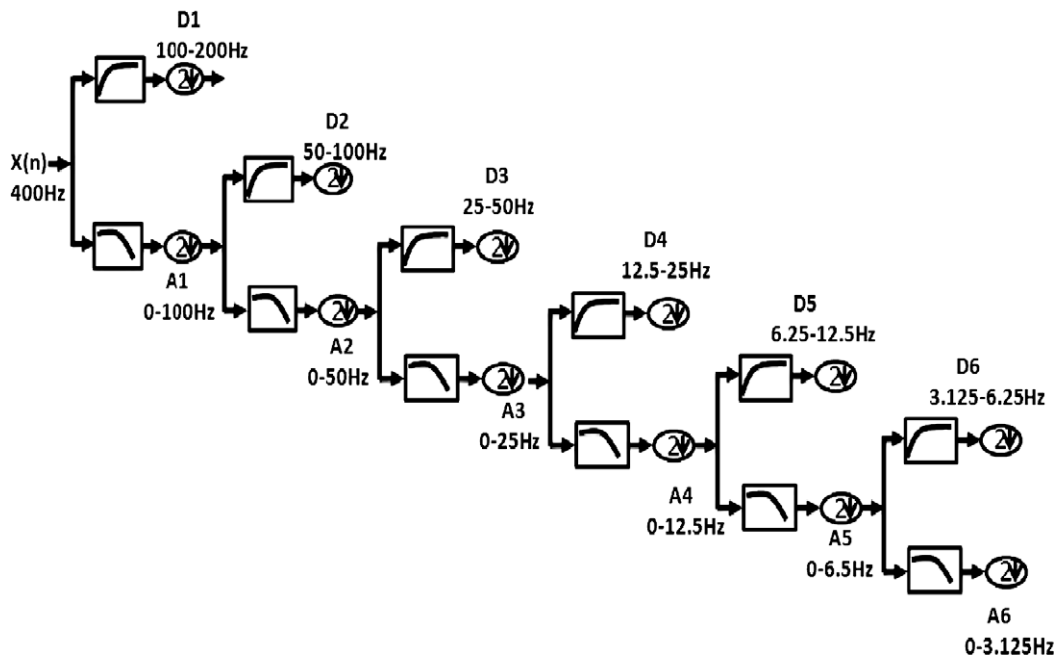

Fig. 3. Structure of sixth-level wavelet decomposition of EEG.

are distinctive because the frequency responses of the two FIR filters separate the high- and low-frequency components of the input signal. The dividing point is usually halfway between 0 Hz and half the data sampling rate (the Nyquist frequency). The outputs of the QMF filter pair are decimated (or de-sampled) by a factor of two. The low-frequency (low-pass) filter output is fed into another identical QMF filter pair. This operation can be repeated recursively as a tree or pyramid algorithm, yielding a group of signals that divides the spectrum of the original signal into octave bands with successively coarser measurements in time as the width of each spectral band narrows and decreases in frequency. The tree or pyramid algorithm can be applied to the WT by using the wavelet coefficients as the filter coefficients of the QMF filter pairs. In WT multi-resolution algorithm (MRA), same wavelet coefficients are used in both low-pass (LP) and high-pass (HP) filters. The LP filter coefficients are associated with the scaling function, and the HP filter is associated with the wavelet function. Fig. 3 shows the tree algorithm of a multi-resolution WT for a discrete EEG signal sampled at 400 Hz. The outputs of the LP filters are called the approximations (A), and the outputs of the HP filters are called the details (D).

2.3. Feature extraction

The proposed analysis using wavelet was carried out using MATLAB wavelet toolbox. The extracted wavelet coefficients provide a compact representation of the signal at different frequency bands which represents the distribution of frequencies components of EEG epileptic signal in time and frequency domain. Fig. 3 represents frequencies corresponding to various levels of decompositions used for the present study. Different features like energy (EDA), entropy and standard deviation (STD) were calculated at each decomposition level starting from D1 to D6 for the epileptic and non-epileptic signals, where energy was found to be the best for classification.

The energy at each decomposition level was calculated using the following equation:

$$ED_i = \sum_{j=1}^N |D_{ij}|^2, \quad i = 1, 2, \dots, l$$

$$EA_l = \sum_{j=1}^N |A_{ij}|^2$$

(10)

$$\text{Standard Deviation } \sigma_i = \left(\frac{1}{N-1} \sum_{j=1}^N (D_{ij} - \mu_i)^2 \right)^{1/2}, \quad i = 1, 2, \dots, l,$$

(11)

where μ_i is the mean and is given by,

$$\mu_i = \frac{1}{N} \sum_{j=1}^N D_{ij}, \quad i = 1, 2, \dots, l,$$

(12)

$$\text{Entropy } ENT_i = - \sum_{j=1}^N D_{ij}^2 \log(D_{ij}^2), \quad i = 1, 2, \dots, l,$$

(13)

where $i = 1, 2, \dots, l$ is the wavelet decomposition level from level 1 to level l . N is the number of coefficients of detail or approximate at each decomposition level.

Thus for a ‘ l ’ level decomposition the feature vector of energy, adopted is of length ‘ l ’ and is denoted by

$$\text{Feature} = [EDA_1 \quad EDA_2 \quad EDA_3 \quad EDA_4 \quad EDA_5 \quad EDA_6]$$

(14)

Figs. 4 and 5) demonstrate the nature of the energy features at different sub-bands.

2.4. Probabilistic neural network (PNN) model

An AI-based classifier is essentially a mapping $f: R_m \rightarrow Z_n$ from the feature space to the discrete class space. An Artificial Neural Network (ANN) implements such a mapping by using a group of interconnected artificial neurons simulating human brain. An ANN can be trained to achieve expected classification results against the input and output information stream, so there is not a need to provide a specified classification algorithm. The PNN model is one among the networks, and has various features distinct from those of other networks in the learning processes (Specht, 1990). It is one kind of distance-based supervised learning ANNs, using a bell shape activation function. This technique makes decision boundaries nonlinear and hence it can approach the Bayesian optimal (Specht, 1998). Compared with traditional back-propagation (BP) neural network, PNN is considered more suitable to medical application since it uses Bayesian strategy, a process familiar to medical decision makers (Orr, 1997). The real-time property of PNN is also crucial to our research. There is no need to train the network over the entire data set again. So we can quickly update our network as more and more patients’ data becomes available.

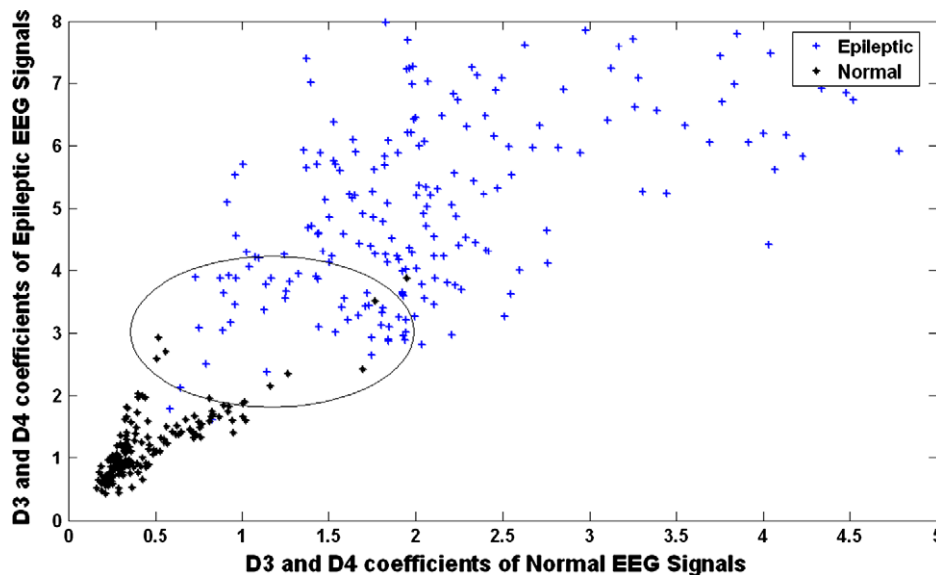

Fig. 4. Feature set of D3 and D4 coefficients of both normal and epileptic EEG signal.

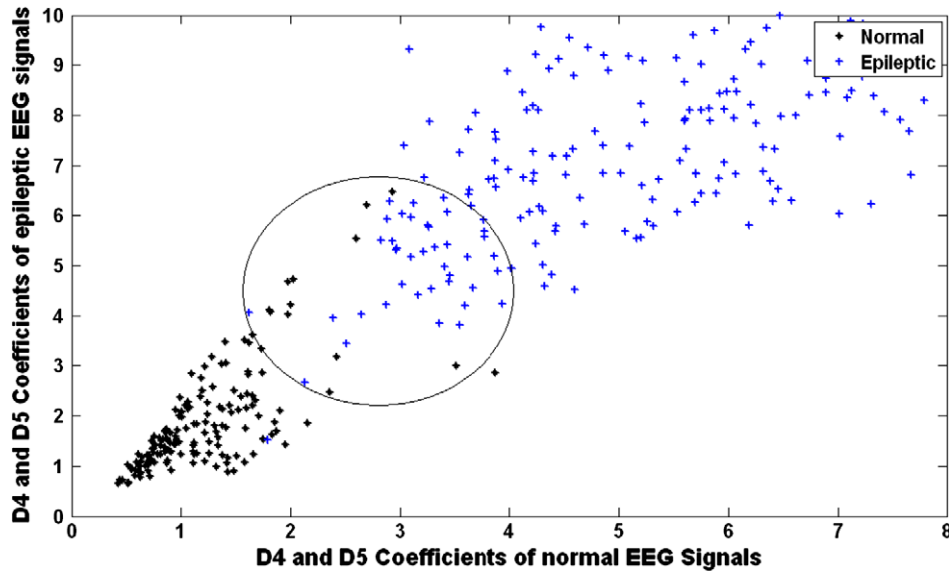

Fig. 5. Feature set of D4 and D5 coefficients of both normal and epileptic subject.

The difference between the inference vector and the target vector are not used to modify the weights of the network. Moreover there is no need to set the initial weights of the network and also there is no relationship between learning process and recalling processes.

The PNN has three layers: the Input Layer, the Radial Basis Layer which evaluates distances between input vector and rows in weight matrix, and the Competitive Layer which determines the class with maximum probability to be correct. The network structure is illustrated in Fig. 6.

The learning speed of the PNN model is very fast, making it suitable for signal analysis and classification problems in real time. Fig. 4 shows the architecture of a PNN model that is composed of the radial basis layer and the competitive layer.

In the signal classification application, the training examples are classified according to their distribution values of probabilistic density function (PDF), which is the basic principle of the PNN. A simple PDF is as follows:

$$f_k(X) = \frac{1}{N_k} \sum_{j=1}^{N_k} \exp\left(-\frac{\|X - X_{kj}\|}{2\sigma^2}\right). \tag{15}$$

The output vector H of the hidden layer in the PNN is as below:

$$H_h = \exp\left(\frac{-\sum_i (X_i - W_{ih}^{xh})^2}{2\sigma^2}\right), \tag{16}$$

$$net_j = \frac{1}{N_j} \sum_h W_{hj}^{hy} H_h \quad \text{and} \quad N_j = \sum_h W_{hj}^{hy},$$

$$net_j = \max_k (net_k) \quad \text{then} \quad y_j = 1, \quad \text{else} \quad y_j = 0, \tag{17}$$

where

- i number of input layers
- h number of hidden layers
- j number of output layers
- k number of training examples
- N number of classifications (clusters)
- σ smoothing parameter (standard deviation)
- X input vector
- $\|X - X_{kj}\|$ Euclidean distance between the vectors X and, X_{kj} , i.e. $\|X - X_{kj}\| = \sum_i (X - X_{kj})^2$
- W_{ih}^{xh} connection weight between the input layer X and the hidden layer H
- W_{hj}^{hy} connection weight between the hidden layer H and the output layer Y

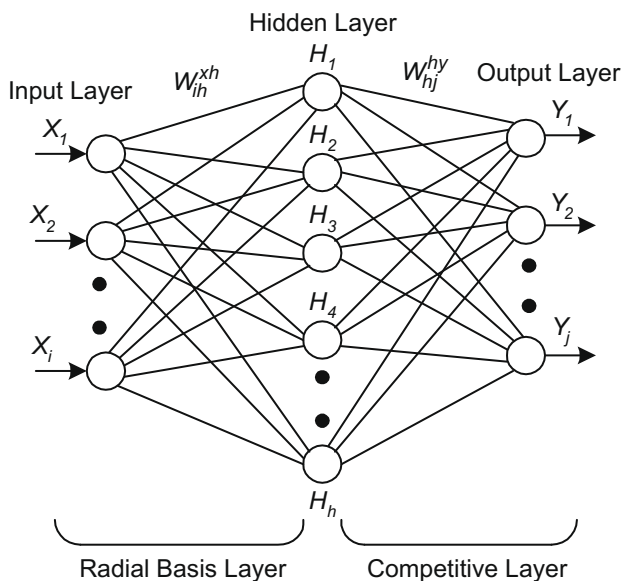

Fig. 6. Architecture of a PNN.

2.5. K-fold cross-validation

Cross-validation, sometimes called rotation estimation (Chang, Luo, & Su, 1992; Devijver & Kittler, 1982; Kohavi, 1995), is the statistical practice of partitioning a sample of data into subsets such that the analysis is initially performed on a single subset, while the other subset(s) are retained for subsequent use in confirming and validating the initial analysis. The initial subset of data is called the training set; the other subset(s) are called validation or testing sets.

In K-fold cross-validation, the original sample is partitioned into K sub-samples. Of the K sub-samples, a single sub-sample is retained as the validation data for testing the model, and the

In order to have a detailed study about how the features affect the classification accuracy, we selected six features at a time as inputs to the PNN. Again the PNN classifier was tested at various spread constants to get the best feature for the classification purpose. Table 1 presents the classification accuracy by selecting one feature set at a time with different PNN spreads. It was observed that when energy or standard deviation of the wavelet coefficients at each level of decomposition was considered as the input features to the PNN, the classification accuracy was better. Energy (EDA), out of the three different feature sets was found to be the best for the classification of epileptic and non-epileptic signals. The 10-fold classification accuracy with energy and standard deviation as the features with a PNN spread of 2 is shown in Table 2.

From Figs. 4 and 5, it was found that the feature sets were inter-mixed for both epileptic and normal signals, which were shown by encircling the region. In spite of the intermixing, the proposed PNN based classifier gives very good accuracy. The average accuracy of classification was 99.33% at a spread constant of 2, when we chose energy as our feature vector. Moreover the time taken for the iteration to complete the classification was just 0.02 s, which is remarkable compared to the other classifier available. Fig. 7 reveals that the detail coefficients of level-3 to level-6 played a significant role in separating epileptic from normal signature.

The proposed PNN classifier with 10-fold cross-validation algorithm for epileptic seizure detection on the EEG data obtained from the hospital data base was implemented using MATLAB R2006b software package with NN Toolbox. EEG data set including 600 segments from both the group (epileptic and normal) were mixed to obtain new input vector set to use 10-fold cross-validation. In this process, the 10-fold scheme divided the whole data set into 10 subsets. One of the 10 subsets was used as the test and the other subsets were put together to form a training set. The process was repeated in a cyclic way ten times to train and test for PNN. In this

technique, all subsets were used for both training and testing and each observation was used for validation exactly once. The results of classification accuracy, execution time for each iteration, sensitivity and specificity were computed and the best model was decided as shown in the Table 3.

The proposed approach is giving an accuracy of 99.33% which is similar to the results obtained by Tezel and Ozbay (2009). Moreover, the time per run is 0.02 s in this proposed classifier, which outperformed all other classifier reported earlier. The higher sensitivity, higher specificity and faster execution prove the feasibility of real time monitoring of epileptic seizures by using this expert model.

4. Conclusion

An automated expert model was developed for detection of epileptic seizure on the background of EEG by using PNN. The real-time property of PNN was a crucial feature for the development of this type of model. In order to train this expert system, the energy of the wavelet coefficients at different sub-bands of the decomposition tree was taken. As the range of frequency of epileptic signals is wide from 6 Hz to 80 Hz, the proposed classifier produces good accuracy for a wide variety of signals. The PNN used for the epileptic activity detection was trained, cross validated and tested with the features extracted from DWT of the EEG signals obtained from both normal as well as epileptic subjects on a real time EEG database collected from Sir Gangaram Hospital, New Delhi. An accuracy rate of 99.33% was achieved by the expert classifier model. The sensitivity and specificity for the seizure detection were found to be 99.6% and 99%, respectively. The classification time of 0.02 s is promising. The combination of extremely low computational time and high accuracy of classification makes this said system more robust and an improvement on the existing real time diagnostic tools for physicians.

Acknowledgments

The authors are thankful to the authority of Sir Gangaram Hospital, New Delhi for giving access to their epileptic EEG database.

References

Adeli, H., Zhou, Z., & Dadmehr, N. (2003). Analysis of EEG records in an epileptic patient using wavelet transform. *Journal of Neuroscience Methods*, 123, 69–87.

Boashash, B., Mesbah, M., & Colditz, P. (2003). *Time frequency analysis*. Elsevier Science.

Chang, J., Luo, Y., Su, K. (1992). GPM: A Generalized Probabilistic Semantic Model for ambiguity resolution. In Proceedings of the 30th annual meeting on association for computational linguistics (Newark, Delaware, June 28–July 02, 1992). Annual meeting of the ACL. Association for computational linguistics, Morristown, NJ (pp. 177–184).

Devijver, P. A., & Kittler, J. (1982). *Pattern recognition: A statistical approach*. London: Prentice-Hall.

Goswami, J. C. (1999). *Fundamentals of wavelets*. New York: Wiley.

Hjorth, B. (1970). EEG analysis based on time domain properties. *Electroencephalography and Clinical Neurophysiology*, 29, 306–310.

Iasemidis, L. D., Shiau, D. S., Chaovalitwongsa, W. (2003). Adaptive epileptic seizure predication system. *IEEE Transaction Biomedical Engineering*, 50(5), 616–627. <<http://www.who.int/topics/epilepsy/en/>>.

Kannathal, N., Choo, M. L., Acharya, U. R., & Sadasivan, P. K. (2005). Entropy for detection of epilepsy in EEG. *Computer Methods and Programs in Biomedicine*, 80, 187–194.

Khan, Y. U., & Gotman, J. (2003). Wavelet based automatic seizure detection in intracerebral electroencephalography. *Clinical Neurophysiology*, 114, 898–908.

Kiyimik, M. K., Subasi, A., & Ozealik, H. R. (2004). Neural networks with periodogram and autoregressive spectral analysis methods in detection of epileptic seizure. *Journal of Medical Systems*, 28(6), 511–522.

Kohavi, R. (1995). A study of cross validation and boot strap for accuracy estimation and model selection. In *Proceedings of the 14th international joint conference on artificial intelligence* (Vol. 2(12), pp. 1137–1143).

Kohavi, R., & Provost, F. (1998). Glossary of terms. Editorial for the special Issue on applications of machine learning and the knowledge discovery process. *Machine Learning*, 30(2/3), 271–274.

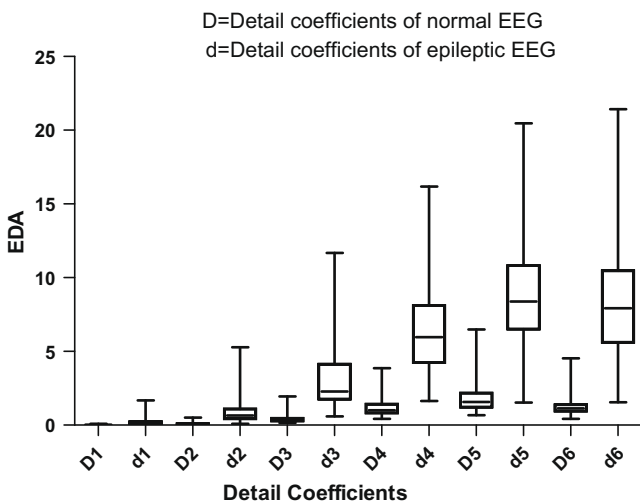

Fig. 7. Box plot of the EDA values of the D1–D6 coefficients for both normal and epileptic data.

Table 3 Results of PNN with various parameters to decide the best model.

Parameters	Averaged training accuracy (%)	Averaged testing accuracy (%)	Training error (%)	Testing error (%)	Time (s)	SN (%)	SP (%)
EDA	100	99.33	0	0.67	0.02	99.6	99
STD	100	97.9	0	2.1	0.11	98.2	97.6

- Kurth, C., Gilliam, F., & Steinhoff, B. J. (2000). EEG Spike detection with a Kohonen feature map. *Annals of Biomedical Engineering*, 28, 1362–1369.
- Liu, A., Hahn, J. S., Heldt, G. P., & Coen, R. W. (1992). Detection of neonatal seizures through computerized EEG analysis. *Electroencephalography and Clinical Neurophysiology*, 82, 30–37.
- Mallat, S. (1998). *A wavelet tour of signal processing*. London, UK: Academic.
- Oeak, H. (2008a). Optimal classification of epileptic seizures in EEG using wavelet analysis and genetic algorithm. *Signal Processing*, 88, 1858–1867.
- Oeak, H. (2008b). Automatic detection of epileptic seizures in EEG using discrete wavelet transform and approximate entropy. *Expert Systems with Applications*.
- Orr, R. K. (1997). Use of a probabilistic neural network to estimate the risk of mortality after cardiac surgery. *Medical Decision Making*, 17(2), 178–185.
- Pavlopoulos, S., Istepanian, R. S. H., Kyriakon, E., Koutsounis, D. (2000). Optimal wavelet biosignal compression for mobile multipurpose telemedicine. In *Proceedings of IEEE EMBS international conference on information technology application in biomedicine*. doi:10.1109/ITAb.2000.892360.
- Sanei, S., & Chambers, J. A. (2007). *EEG signal processing* (pp. 161–195). John Wiley and Sons, Ltd..
- Saraceno, B., Avanzini, G., Lee, P. (2005). Atlas: Epilepsy care in the world. Geneva: WHO. <http://www.who.int/mental_health/neurology/epilepsy_atlas_r1.pdf>.
- Specht, D., (1998). Probabilistic neural networks for classification mapping, or associative memory. In *Proceedings of 1988 IEEE international conference on neural networks* (Vol. 1).
- Subasi, A. (2005). Epileptic seizure detection using dynamic wavelet network. *Expert System with Application*, 29, 343–355.
- Subasi, A. (2006). Automatic detection of epileptic seizure using dynamic fuzzy neural networks. *Expert Systems with Applications*, 31, 320–328.
- Subasi, A. (2007). EEG signal classification using wavelet function extraction and a mixture of expert model. *Expert System with Application*, 32, 1084–1093.
- Specht, D. (1990). Probabilistic neural networks. *Neural Networks*, 3.
- Tazel, G., & OZbay, Y. (2009). A new approach for epileptic seizure detection using adaptive neural network. *Expert Systems with Applications*, 36, 172–180.
- Tezel, G., & Ozbay, Y. (2009). A new approach for epileptic seizure detection using adaptive neural network. *Expert Systems with Applications*, 36, 172–180.