

## IMPROVING COMPUTATIONAL LOAD OF FXLMS ALGORITHM IN MULTI-CHANNEL ACTIVE NOISE CONTROL BY USING A MODIFIED STRUCTURE

Seyede Zahra Jalilzadeh, Mohammad Asgari

*IRIB University, Tehran, Iran*

*e-mail: jalilzadeh@iribu.ac.ir*

This paper concerns Active Noise Control (ANC) of feed-forward multi-channel Filtered-x Least Mean Square (FxLMS) algorithm. The FxLMS algorithm is a preferred algorithm as a controller filter in ANC systems. In spite of its popularity, computational load in multi-channel systems is a main drawback. Among the existing solutions to simplify the computations, one is based on the using only one reference signal, however, in this paper; the proposed structure is based on multi-reference signals filtering in a multi-channel with  $J$  reference microphones. It achieves at the same performance, low computational load in comparison to standard structure of multi-channel FxLMS algorithm. The investigation was based on practical experiments that were done in a server room. What we concluded that the processing time in proposed structure is 90 times lower than standard structure.

### 1. Introduction

Active Noise Control (ANC) is based on the producing of a sound with the same amplitude and out-phase of the unwanted sound [1]. As Fig. 1 shows, in a general feed-forward multi-channel ANC system, there are  $J$  reference sensors,  $K$  control sources and  $M$  error sensors. A multi-channel system is used when there are several noise sources in the space [2].

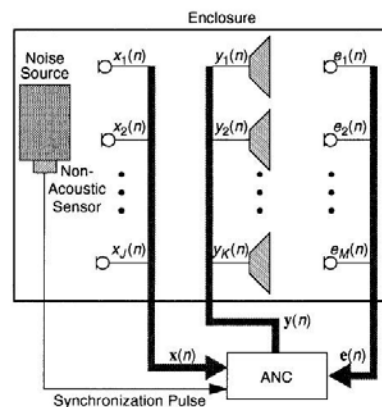

**Figure 1.** The block diagram of a feed-forward multi-channel ANC system,  $J$  references microphones,  $K$  control sources and  $M$  error microphones [1].

The most common adaptation algorithm for ANC system is a modified version of LMS algorithm [3] which is called FxLMS [4]. This algorithm is based on reduction of error signal's variance. The schematic diagram of a single-channel feed-forward ANC system using FxLMS algorithm is shown in Fig. 2.

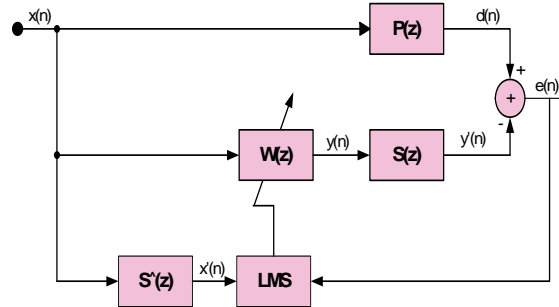

**Figure 2.** The block diagram of FxLMS algorithm in a single-channel ANC system.

The FxLMS [4] algorithm in a multi-channel ANC system is given as:

$$w_{kj}(n+1) = w_{kj}(n) + \mu \sum_{m=0}^{M-1} x'_{jkm}(n) e_m(n) \quad (1)$$

Where  $\mu$  is the step size parameter,  $w_{kj}(n)$  is a tap-weight vector,  $x'_{jkm}(n)$  is the filtered reference signal vector,  $e_m(n)$  is the residual error which is picked up by  $m$ th error microphone.

FxLMS [4] algorithm is a preferred algorithm in ANC system for its tolerance in secondary path modelling [2] and easy implementation [2]. On the other hand, computational complexity is an important disadvantage of FxLMS algorithm especially in multi-channel ANC systems. Computational complexity refers to the number of additions and multiplications in updating the adaptive filters' weights. In practice, due to more computational complexity, more storage is necessary to implement the system. It means that, the complicated system needs to a faster Digital Signal Processing (DSP) with a large memory area to carry out the real time computing.

There has been a very little research on simplification of FxLMS algorithm computational complexity, at least up to the best knowledge of authors.

Regarding Eq. 1, for a constant value for  $\mu$  and impulse response coefficients, it has concluded that the reference signals are important factor in computational load. Here, we consider a multi-channel system based on multi-reference signals structure by using a modified structure of FxLMS algorithm to decrease the computational load.

In this paper, we considered a multi-channel ANC system with 5 reference microphones, 4 control sources and one error microphone. The rest of the paper was organized as follows. Section 2 provided a research review on simplification solution at the FxLMS algorithm. Section 3 described a multi-channel ANC system with  $2 \times 2 \times 1$  structure based on standard structure of FxLMS algorithm. Section 4 described the proposed structure for a  $2 \times 2 \times 1$  ANC system based on FxLMS algorithm. The simulation was conducted for a  $5 \times 4 \times 1$  ANC system based on standard and proposed structure of FxLMS algorithm and the conclusion was given in section 6.

## 2. Research Review

In order to simplify the computational load in a multi-channel ANC system, one of the following solutions may be adopted:

- A single reference signal may be used.
- A combination of  $J$  reference signals may be used to form a single reference signal.

The single reference microphone or single reference signal is sufficient to pick up the primary noise for narrow-band noise reduction scenario [5]. Although, most researches on ANC system are

based on two approaches (as explained in this section), it is inevitable to use multi-channel system in a complicated noise field. This system also has some categories.

- Multi-channel system using Multi-Reference Single-Input (MRSI)

In order to decrease the complexity, it is possible to combine J reference signals before sending into the algorithm. This structure is called Multiple Reference - Single Input (MRSI).

- Multi-channel system using Multi-Reference Multi-Input (MRMI)

The application of multiple reference signals is focused on complicated acoustic noise field. Although, working on MRSI systems is easier rather than MRMI systems, the noise attenuation is more by using MRMI systems [5].

### 3. Multi-Reference Multi-Input (MRMI) Structure

To achieve the spatial noise reduction effect, it is essential to extend the analysis of MRMI system to multiple control system. Here, the analysis of a  $2 \times 2 \times 1$  structure of ANC system based on FxLMS algorithm in time domain is provided.  $x_1$  and  $x_2$  are two reference signals.  $w_{kj}$  is the adaptive filter.  $S_{km}$  is the secondary path transfer function; the distance between the error microphone and control source.  $\hat{S}_{km}$  is the estimation of secondary path transfer function and  $e$  is the residual error. As Fig.3 shows, we have:

$$y_k(n) = \sum_{j=1}^J W_{kj}^T(n) x_j(n) \quad (2)$$

where  $y_k(n)$  is the kth secondary signal.

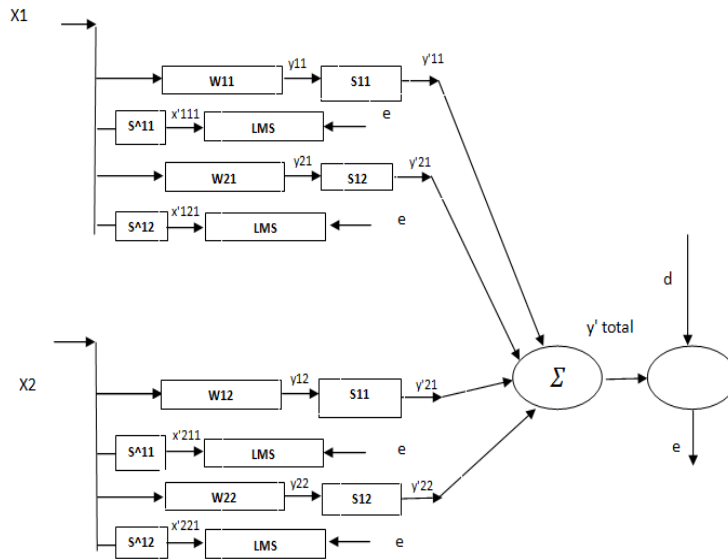

**Fig.3.** Block diagram of FxLMS algorithm based on  $2 \times 2 \times 1$  structure of feed-forward ANC system.

The adaptation of algorithm is given as:

$$w_{kj}(n+1) = w_{kj}(n) + \mu \sum_{m=0}^{M-1} x'_{jkm}(n) e_m(n) \quad (3)$$

Where  $\mu$  is the step size. It is stated the execution of FxLMS [4] algorithm depends on the number of control sources (K) and the reference microphones (J). Here, FxLMS algorithm is executed  $2 \times 2$  times as given as:

$$\begin{aligned} w_{11}(n+1) &= w_{11}(n) + \mu x'_{111}(n)e(n) \\ w_{21}(n+1) &= w_{21}(n) + \mu x'_{121}(n)e(n) \end{aligned} \quad (4)$$

$$\begin{aligned} w_{12}(n+1) &= w_{12}(n) + \mu x'_{211}(n)e(n) \\ w_{22}(n+1) &= w_{22}(n) + \mu x'_{221}(n)e(n) \end{aligned} \quad (5)$$

#### 4. Proposed Structure

Here, we proposed a structure to decrease the computational load and processing time. The proposed structure of FxLMS [4] is a modified version of FxLMS MRMI structure. The block diagram of FxLMS algorithm based on modified feed-forward multi-channel ANC as is shown in Fig. 4.

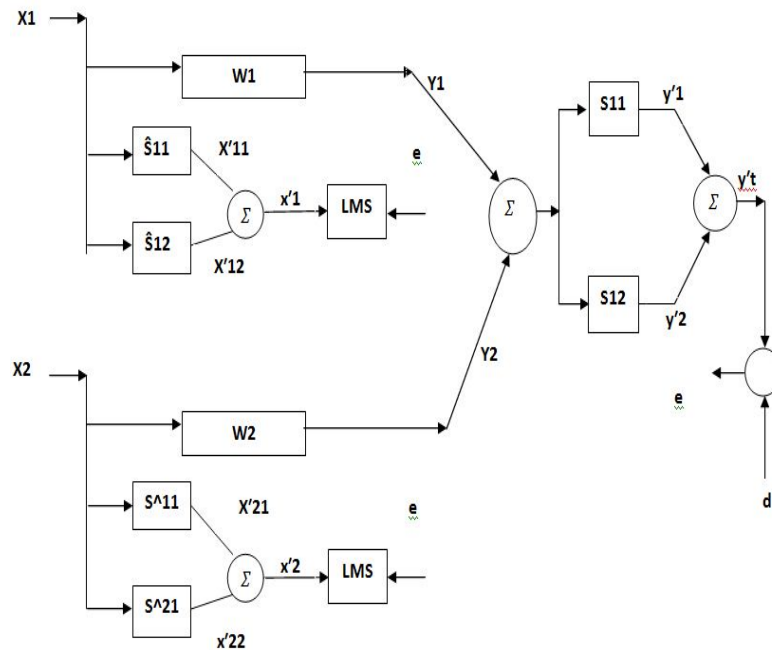

**Fig.4.** Block diagram of modified FxLMS algorithm based on  $2 \times 2 \times 1$  structure of feed-forward ANC system.

Assuming that  $w_j(z)$  is an FIR filter of tap-weight length  $L$ ,  
The total secondary signal  $y(n)$  is expressed as

$$y(n) = \sum_{j=1}^J W_j^T(z) x_j(n) \quad (6)$$

Where  $x_j(n)$  is the  $j$ th reference signal.

And using this modified reference signals' filtering is given as:

$$x'_{jkm}(n) = \sum_{v=1}^K \hat{S}_{km}(n) * x_j(n) \quad (7)$$

Finally, the adaptation algorithm is given as:

$$W_j(n) = W_j(n) + \mu \sum_{m=1}^M x'_{jkm}(n) e_m(n) \quad (8)$$

For a  $2 \times 2 \times 1$  structure we have:

$$\begin{aligned} w_1(n+1) &= w_1(n) + \mu x'_1(n) e(n) \\ w_2(n+1) &= w_2(n) + \mu x'_2(n) e(n) \end{aligned} \quad (9)$$

It is clear that the execution of FxLMS algorithm is decreased to two times instead of four.

## 5. Computer simulation

This section provides the simulation results to verify the effectiveness of the proposed structure in comparison to the standard FxLMS algorithm structure. The system to be simulated included five reference microphones, four control sources and one error microphone. The acoustic paths were modelled practically. The data belongs to the Islamic Republic of Iran Broadcasting (IRIB) data center server room. Secondary paths were modelled to 8-tap IIR filter. The estimated secondary paths modelling were also 32-tap FIR filter. The adaptive filter  $w(n)$  was selected an 128-tap FIR filter. The frequency and phase response of secondary path was shown in Fig.5. The processing was done by Dell Vostro [6] lap top with 4 Gig Ram.

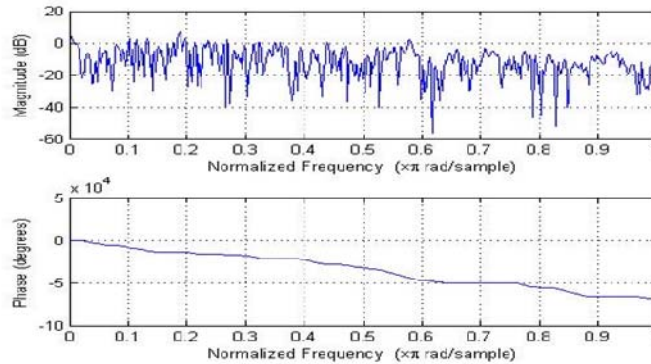

**Figure 5.** The frequency response of acoustic path used in computer simulations based on practical experiments.

The simulation parameters were shown in Table.1.

**Table 1.** Simulation Parameters.

Filter modelling	Filter name	Filter type	Filter tap
Adaptive filter	$W(z)$	FIR	128 tap
Secondary paths modelling	$S(z)$	IIR	8 order
Estimated secondary paths	$\hat{S}(z)$	FIR	32 tap

We used signals' power rate as the performance, being defined as:

$$performance = 20 \log_{10} \left( \frac{|d|}{|e|} \right) \quad (10)$$

Where  $d$  is the desired (primary noise) signal and  $e$  is the residual noise. To evaluate the attenuation of computational load, processing time to implement the FxLMS [4] algorithm, has also been regarded.

Here, various band-widths of primary noise were regarded to evaluate the system performance. The band-widths were selected based on maximum values of amplitudes. The simulation results were shown in Fig. 6 to Fig. 10.

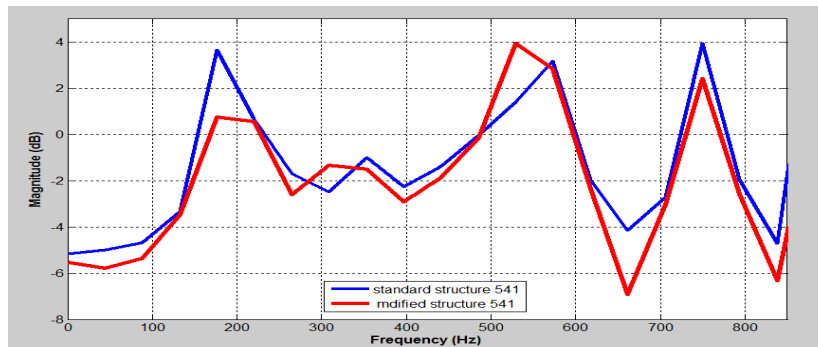

**Figure 6.** The power of residual noise based on FxLMS algorithm using standard (blue line) and modified (red line) algorithm over 80 to 800 Hz.

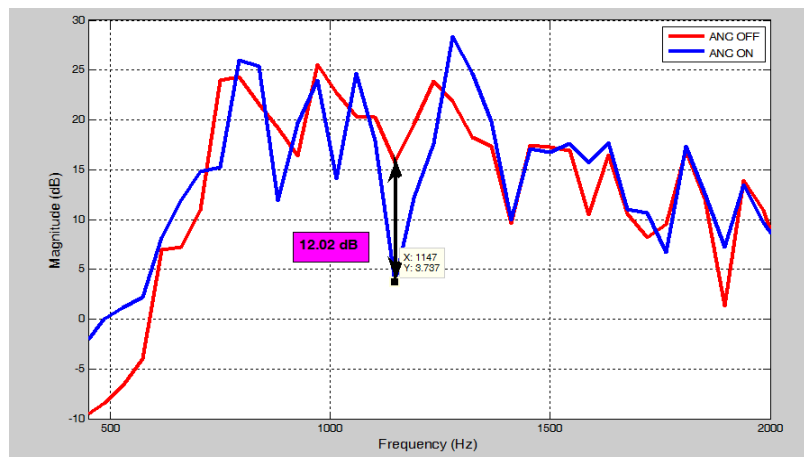

**Figure 7.** The power of primary and residual noise based on FxLMS algorithm using standard algorithm over 500 to 2000 Hz.

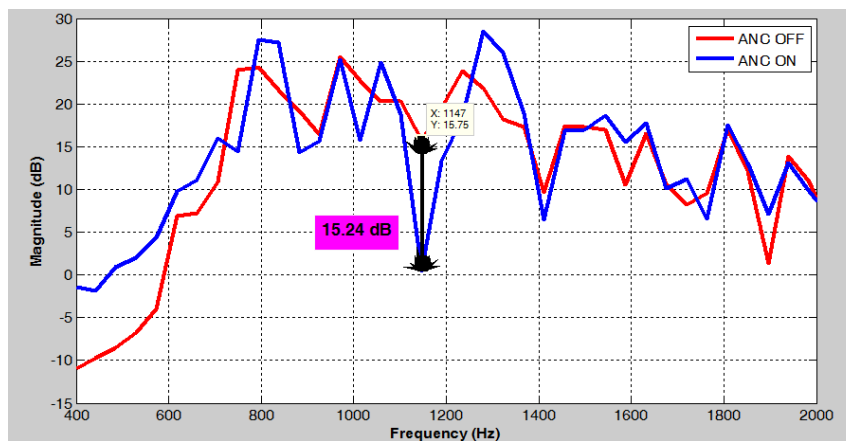

**Figure 8.** The power of primary and residual noise based on FxLMS algorithm using modified algorithm over 500 to 2000 Hz.

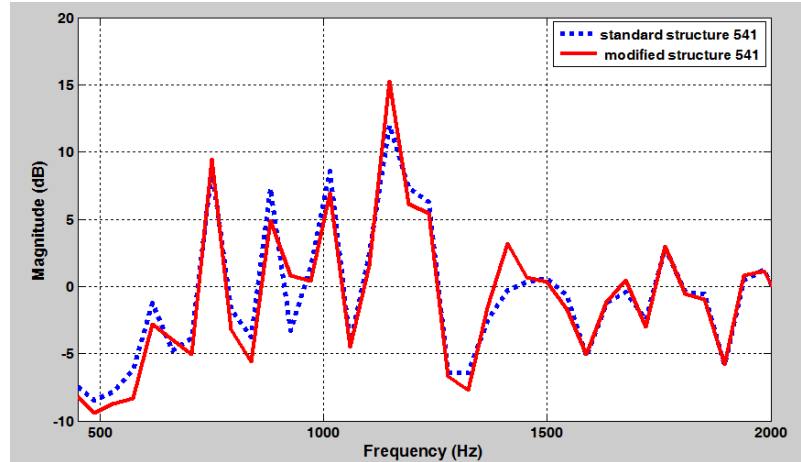

**Figure 9.** The power of residual noise based on FxLMS algorithm using standard (blue line) and modified (red line) algorithm over 500 to 2000 Hz.

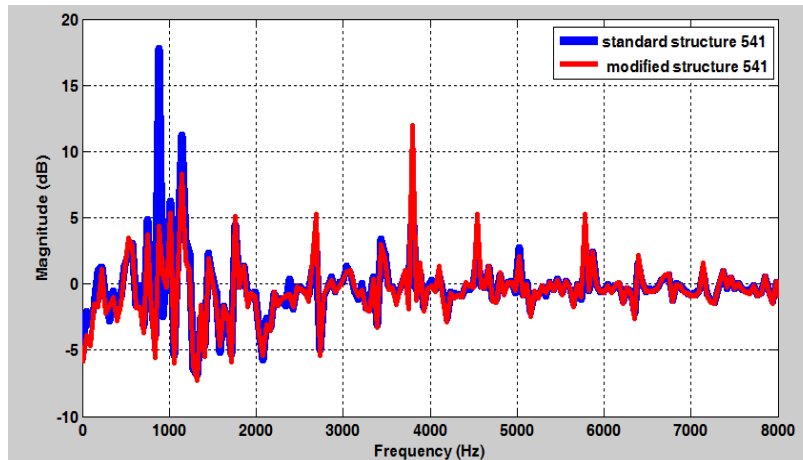

**Figure 10.** The power of residual noise based on FxLMS algorithm using standard (blue line) and modified (red line) algorithm over 80 to 8000 Hz.

**Table 2.** Simulation results for standard and modified structures for multi frequency band.

Band-Width (Hz)	600 to 800		80 to 800		500 to 2000		80 to 8000	
	Noise attenuation (dB)	Processing Time (s)	Noise attenuation (dB)	Processing Time (s)	Noise attenuation (dB)	Processing Time	Noise attenuation (dB)	Processing Time
Standard structure	-1.82	0.92	-1.43	0.99	0.48	1.07 min	0.28	3.73 min
Modified structure	-2.19	0.72	-2.30	0.73	0.55	0.71 s	0.43	0.71 s

The simulation results were:

- 1- There is no relationship between the noise band-width and the attenuation.
- 2- 500 to 2000 Hz was the best band-width to have best performance in noise attenuation.

3- processing Time by using modified structure for 500 to 2000 Hz band-width was 90 times smaller than standard structure's one.

4- Regarding the results provided in Table.2, the modified structure was more effective in wide-band noise reduction.

5- The modified structure is more effective to reduce the frequencies above 1000 Hz.

## 6. Conclusions

In this paper we have presented a modified structure of FxLMS [4] algorithm to decrease the computational load in MRMI systems. The main idea to modify the structure was based on reference signals' filtering method. It was shown that the proposed structure has less processing time and good stability for ANC at wide-band noise attenuation. As the simulation parameters were real based on practical experiments, the results are valid for experimental scenarios.

## REFERENCES

- <sup>1</sup> Sen, M.Kuo and Dennis, R. Morgan, *Active Noise Control Systems, Algorithms and DSP Implementations*, John Wiley & Sons, (1996).
- <sup>2</sup> Sen, M. Kuo and Dennis, R. Morgan, *Active Noise Control: A Tutorial Review*, Proceeding Of the IEEE, June, (1999).
- <sup>3</sup> Farhang, Boroujeni, *Adaptive Filters- Theory and Application*, John Wiley & Sons.
- <sup>4</sup> ThomaKletschkowski, *Adaptive Feed-Forward control of low frequency interior Noise*, Springer, (2012).
- <sup>5</sup> Tu, Y., *Multiple Reference Active Noise Control*, Master of Science Thesis, Blacksburg University, (1997).
- <sup>6</sup> [Online.]: [http://www.floralimited.com/images/PDF/Vostro\\_1320,\\_1520\\_1720\\_Brochure.pdf](http://www.floralimited.com/images/PDF/Vostro_1320,_1520_1720_Brochure.pdf)