

TIMING TEST OF HIGH VOLTAGE THREE PHASE CIRCUIT BREAKER USING DIGITAL TIME PULSE CONVERSION METHOD

S.Dhivya¹, K.Sakthivel²

Assistant Professor^{1 2}

Department of EEE, BIST, BIHER, Bharath University, Chennai.

dhivya.eee@bharathuniv.ac.in

Abstract— The paper presents the construction and principle of operation of a designed and constructed meter for testing the operation times of three-phase circuit breakers. The measurement is performed by the digital time-pulse conversion method. The design is based on a PLC controller. The block scheme of the meter and principle of operation are given, along with the results illustrating the metrological parameters of the device.

Circuit breakers constitute an essential and basic segment in the Electric Power System. On account of their key part, circuit breakers are occasionally tried. One of the soonest and best test techniques was the planning test, which comprises of measuring the mechanical operation time of the breakers contacts. Timing tests will dependably be essential to counteract harms of electrical switch. Off base operation of electrical switch can have of shocking results on the hardware or the substation work force.

Different measuring devices can measure the operation times of a breaker. First- generation devices were based on oscillographic mode of record curves and currently are not used. Second generation testing methods based on digital timers with time-pulse conversion

Generally commercially produced timers for testing circuit-breakers are expensive. Information on the design and principle of operation of the offered devices are usually too general or unavailable. In view of the above, an attempt was made at developing our own solution of design of a microprocessor-based meter for measurements of operation times of three-phase circuit-breakers.

Index Terms— **Circuit Breaker operation and Maintenance, Timing test**

I. INTRODUCTION

Circuit breakers constitute an important and critical component in the electric power system. Because of their key role, circuit breakers are periodically tested. One of the most successful test methods was the timing test, which consists of measuring the mechanical operation time of the breakers contacts[1-5]. Timing tests will always be important to prevent damages of circuit breaker. Incorrect operation of circuit breaker can have of disastrous consequences on the equipment or the substation personnel. Different measuring devices can measure the operation times of a breaker[6-11]. First- generation devices were based on oscillographic mode of record curves and currently are not used. Second generation testing methods based on digital timers with time-pulse conversion. But in this project we are utilizing the

opportunities of a modern PLC system to perform an accurate testing.

The planning of a breaker is the time estimation of the mechanical operations keeping in mind the end goal to check its honesty and great working request. Mechanical operation implies all operation or cycle of operation the breaker is expected to manage without being associated with the power lattice[12-18]. It is an important to time every breaker, so as to have its utilitarian mark. Off base operation can have tragic results on the gear or the substation faculty. Also the out of administration misfortunes of income and the repair costs. Timing tests are done first in the production line amid the standard tests and after establishment, amid the authorizing tests. They must be done intermittently keeping in mind the end goal to approve the great working request and unwavering quality of the breaker.

In order to measure the operation times of a breaker, we need a device capable of detecting the instant of contact's state changing starting from the point the order was launched .This device sends electric signals via cables connected to each contact, in the case of several contacts in series each signal has its own source to eliminate interference. The signal has two possible states. The first is when the contact is closed, the second when the contact is open. All is recorded for consultation and analysis[19-24]. These special devices are called timing machines or circuit breaker analyzers. They are designed to generate all the needed signals and incorporate a data acquisition system. The Important parameters describing the technical quality of a three-phase circuit-breaker are the so-called operation times characterising the processes of the contacts opening and closure. Definitions of these time parameters are presented in international standards IEC 56.3.105.The quantitative description of the switching on and off process is usually made with the help of the mentioned below time parameters:

1. Time discrepancy between the contacts 'td' - interval time characterising the divergence from coincidence of connection or disconnection of the breaker contacts (non-simultaneous switching)
2. Closing time 'tc' of the breaker – the interval of time between energizing the closing circuit, the circuit breaker being in the open position, and the instant when the contacts touch the poles
3. Opening time 'to' of the breaker - The interval of time between the instant of energizing the opening release, the circuit breaker being in the closed position, and the instant when the contacts have separated in all poles [25-29]

OBJECTIVES

- Increase the reliability of the Power System
- Reduce the down time & Maintenance cost
- To design a powerful tool for troubleshooting

Electricity is a natural phenomenon. It is a part of matter as negatively charged electrons and positively charged protons. Generating stations, usually located in remote areas far from the main centers of consumption, generates it by transforming other forms of energy (mechanical, thermal, solar, nuclear, etc.). Electricity thus produced is transported via the power transmission lines and distributed to consumers via the distribution grid. The electrical power must always be available, without interruption, to the consumer, even if the consumer does not use it continuously.

The power utilities divide their networks into two broad categories:

1. The transport network
2. The distribution network

At the output of the generating stations, transforming stations step up the production-level voltage to the high voltage necessary to efficiently carry the electricity over longer distances. The power transmission lines are made of conductors such as overhead lines or underground cables. In spite of their apparent simplicity, these conductors conceal important influencing factors to the electricity transmission network[30-34].

POWER CIRCUIT INTERRUPTERS

A power network needs to constantly change the circuits' configurations. That means to put in or out of service this or that part of the installation. Power circuit interrupters include a number of apparatus with the main task to connect and disconnect power circuits rated 1000 Volts and higher. [2]

Main circuit interrupters are:

- a) Disconnect-switch:

It is mainly used to isolate equipment or portion of a circuit for repair or maintenance. The disconnect switch has little or no current interrupting abilities. Its operation has to be done without any current flow in the circuit. It is a safety device with, usually, a visible breaking contact and it can be locked in the open position.

- b) Interrupter:

It is a switch designed to close or open circuits and make or interrupt nominal currents. It is faster than a disconnect-switch and has current breaking capability.

- c) Circuit-breaker:

The circuit breaker fills the same function as an interrupter but has the ability to interrupt short circuit currents as well. It is the ultimate protection device on the power-network.[2]

MAINTENANCE STRATEGY

Corrective Maintenance - : It consists of intervening only on faults and only to correct and repair. This strategy has the advantage of spending only on service and parts needed in real time. It also avoids unnecessary spending on periodic maintenance and testing. On the other hand, the consequences of faulty interrupting equipment may disastrous and very costly in terms of power interruptions to consumers and the extent of damage to the equipment and surroundings, not to mention human safety. The gains expected on maintenance will quickly fade relative to high the high cost of repair and loss of revenue due to power loss.

Periodic Maintenance -: It is a series of predetermined actions executed periodically, independently of the condition of the equipment. This method, if applied strictly, can cause a great deal of unnecessary work and increased costs.

Preventive Maintenance -: It is based on maintenance relying on the actual condition of the equipment. In order to state the condition of the equipment, extensive testing and statistical analyses are conducted periodically and based on experience and new technologies (computers, communications, monitoring, etc.), corrective interventions are planned.

CIRCUIT BREAKER TESTING

Every circuit breaker is factory tested (routine testing) before delivery, tested again on site after installation (commissioning tests), and periodically after that until the end of its life. These tests are necessary to determine the real condition of the circuit breaker before starting service, to be able to establish a starting point to trace its evolution[35-39]. One of the most important tests among these is the timing test, and it includes:

Measuring the exact instant that the contacts change states

Verify the contact's discrepancy.

Verify the contact's travel and speed.

The measured values are compared with the established tolerance's limits. Most often, the commissioning test values are used as reference values. Any deviation from these values can indicate, with the right analysis, what course of action is to be taken. Before going deeper in discussing timing tests, we need to understand the circuit breaker first. [2]

THE CIRCUIT BREAKER

The circuit breaker is the most important and complicated of all types of power circuit interruption equipment. This is due to its highly important capability of interrupting the powerful short circuit current, over and above its normal role of conducting, isolating and interrupting nominal load currents. Its structure can be divided to three major parts:

Power Circuit

It is where the main current flows or is interrupted; and it includes:

- a. Arcing chamber

The arcing chamber is a closed volume containing a fixed contact, a moving contact and the interrupting medium. The current is established when the moving contact touches the fixed contact and interrupted when they part. An arc is created when the contacts part. The interrupting medium is responsible for quenching the arc and establishing the nominal level of isolation between the open contacts[40-45].

- b. Insertion resistor

The sudden modification of circuit characteristics, when circuit breakers operate, produces peak voltage impulses where the level is determined by the circuit characteristics. These impulses may reach very high levels and must be reduced. A well-known method is closing or opening in two or three steps on resistors.

On Trip - The voltage impulse levels are generally acceptable when interrupting nominal or short circuit currents, but they can be dangerously high when interrupting small capacitive or inductive currents.

On close - Sudden energizing of a circuit always generates voltage impulses with usually moderate levels, with the exception of closing or reclosing on long unloaded lines where the impulses, function of the line length, of the instant of closing or reclosing and of the discrepancy of the three poles can reach extremely high levels.

Operating Mechanism

It is where the needed energy to part the contacts and to extinguish the arc is developed. It includes devices, called energy accumulators, to store the needed energy. Examples of accumulators are:

Springs , Nitrogen-charged cylinders

The most common operating mechanisms in circuit breakers are:

Spring operated
Hydraulically operated
Pneumatically operated

Control Circuit

The order to operate the breaker is launched in the control part of the circuit breaker, as an electric impulse of a fraction of a second duration. The order is then amplified in the operating mechanism to a complete circuit breaker operation capable of interrupting short circuit currents. The control includes:

Closing and tripping coils
Control relaying system
Pressure switches and gauges
Surveillance and alarm system
Re-inflating system to restore the energy spent on the operation

CIRCUIT BREAKER TYPES

The main problem of circuit breakers stems from the nature of their existence. A circuit breaker has to interrupt weak capacitive or inductive currents, up to high short circuit currents, and as a result, to extinguish powerful electric arcs. The problem is then, essentially, an arcing problem. Another problem is overvoltage impulses; this is related to the nature of the circuit where it is installed. One of the major factors influencing the capacity of circuit breakers is the interrupting medium. It affects circuit breakers' concept and design. By this principle, circuit breakers are classified in families according to the type of interrupting medium used.

Periodic Maintenance -: It is a series of predetermined actions executed periodically, independently of the condition of the

equipment. This method, if applied strictly, can cause a great deal of unnecessary work and increased costs.

Interrupting Medium

A good number of substances have acceptable qualities to be interrupting mediums. Three of them are widely preferred by circuit breaker designers around the world. This is due to their excellent breaking and insulating properties that lead to high performance and economic designs. They are:

Mineral oil
Compressed air
Vacuum
Sulfur hexafluoride, or SF₆

Mineral oil

Mineral oil was, until recently, the interrupting medium of choice. It has excellent breaking and insulating quality especially when it is very pure, as is the case when it is used in certain devices such as capacitors or transformers, which are airtight devices. However, circuit breakers have breathing holes and the oil is in contact with the arc. Thus, one finds in the breaker's oil a certain amount of impurities, in the form of moisture and miscellaneous dust, including carbon particles. This decreases its isolation properties significantly. It is imperative to monitor the state of the oil inside breakers in service, and to replace it periodically in function of the number of breaks performed by the device. The criteria for oil replacement depend on the structure of the breakers and are indicated by the manufacturer.

Oil Circuit Breaker

The first high voltage breakers were the bulk oil circuit breakers, followed by the minimum oil circuit breakers. In an oil circuit breaker, the arc decomposes part of the oil into gases composed of 70% Hydrogen and 20% Acetylene, and also produces carbon particle

Bulk Oil Circuit Breaker:

It consists of a steel tank partly filled with oil, through the cover of which is mounted porcelain or composite insulating bushings. Contacts at the bottom of the bushings are bridged by a conducting cross head carried by a wooden or composite lift rod, which in common designs drops by gravity following contact separation by spring action, thus opening the breaker. An air cushion above the oil level serves as an expansion volume to prevent pressure from building up inside the chamber after the interruption of the short circuit current. Regardless of improvements, the bulk oil circuit breaker presents many disadvantages:

Great weight and bulk
Risk of fire
Strong reaction to ground

Minimum Oil Circuit Breaker:

These breakers were developed for 170 and 245 kV systems,

the highest voltages at the time, where the inherent problems of bulk oil breakers were the most severe, also to eliminate oil as insulating medium and thus reduce the quantity of oil in switchgear installations to an amount that would not cause any hazard. The excellent arc-quenching properties of oil, however, were used later in specially developed oil- and pressure-tight arc-interrupting chambers. Minimum oil circuit breakers for high voltage are single-interrupter up to 170 kV and multiple-interrupter breakers for 230 kV and higher.

Most of minimum oil circuit breakers are designed for fast reclose. They have to be able to interrupt short circuit currents twice in a row with 0.2 sec to 0.3-sec interval; therefore the arc-control device has to contain enough oil to succeed in performing the second interruption.

b. Compressed Air:

The insulating quality of air rises rapidly with its pressure. In practice we can count on a disruption voltage of up to 90 kV between contacts separated by 1 cm at 10 bars pressure, and 1.5 times this value for the same distance at 20 bars pressure. Compressed air was mainly used for interruption in the earlier pneumatic circuit breaker designs. Later on it was used for insulation between the contacts after they opened, the latter being placed inside an insulating chamber designed to resist the air pressure. This reduced significantly the distance between the open contacts.

Air quality for pneumatic circuit breakers - It should be noted that the excellent quality of air is greatly affected by the humidity. Indeed, it is important that any condensation in the insulators and air conduits be avoided, or internal tripping may occur. Installing the costly drying compression stations greatly raises the cost of operating air blast circuit breakers.

Air Blast Circuit Breaker

Until recently, the air blast circuit breakers have dominated the high and very high voltage applications. From 170 kV to 800 kV and breaking capacity from 20 kA to 100 kA. Over 100 kV the breaker has multiple chambers connected in series. Each element is optimized to around 80 kV. At first, 800 kV breakers had 12 chambers in series per phase, now they have only 8 chambers per phase. Although increasing the air pressure increases the speed of dielectric regeneration, it is still relatively slow. Insertion resistors are often used to reduce voltage surges. Air blast circuit breakers adapt well to the high-voltage power network's new demands. The compressed air circuit breaker has two major disadvantages: Installation of expensive compression stations, High noise levels-on-operation [2]

c. Vacuum:

This technology is suitable for mainly medium voltage and high voltage application. For extra higher voltage vacuum technology has been developed but not commercially viable. The operation of opening and closing of current carrying contacts and associated arc interruption take place in a vacuum chamber in the breaker which is called vacuum interrupter. The vacuum interrupter consists of a steel arc chamber in the centre symmetrically arranged ceramic insulators. The vacuum pressure inside a vacuum interrupter is normally maintained at 10^{-6} bar.

Vacuum Circuit Breaker

A vacuum circuit breaker is such kind of circuit breaker where the arc quenching takes place in vacuum. The material used for current carrying contacts plays an important role in the performance of the vacuum circuit breaker. Copper is the most ideal material to make VCB contacts. Vacuum interrupter technology was first introduced in the year of 1960. But still it is a developing technology. As time goes on, the size of the vacuum interrupter is being reducing from its early 1960's size due to different technical developments in this field of engineering. The contact geometry is also improving with time, from butt contact of early days it gradually changes to spiral shape, cup shape and axial magnetic field contact. The vacuum circuit breaker is today recognized as most reliable current interruption technology for medium and high voltage switchgear. It requires minimum maintenance compared to other circuit breaker technologies. [4]

d. Sulfur Hexafluoride, SF₆

A certain number of gases, called electronegative, have better insulating qualities than air. Among them is sulfur hexafluoride, SF₆, has seen a great deal of success in electrical apparatus design because of its excellent insulating properties and remarkable arc quenching abilities. It is five times heavier than air, odorless, colorless, nonflammable and non-toxic when new. Its dielectric strength is 3 times the air's dielectric. When subjected to an electric arc, it partially decomposes. In the presence of moisture and impurities it produces acid by-products that attack metal and the insulating envelopes. An efficient way to reduce by-products is to use activated alumina inside the chambers containing the gas. SF₆ being a gas at normal temperatures, and at atmospheric pressure it liquefies at -60 °C, and at 20 bars it liquefies at 20 °C, which is detrimental to its insulating qualities. For applications at very cold temperatures, it must be heated or mixed with other gases like Nitrogen or CF₄.

Sulfur hexafluoride (SF₆) gas has proved to be an excellent arc-quenching and insulation medium for circuit breakers. SF₆ breakers are available for all voltages ranging from 14.4 kV to 800 kV, continuous current up to 4000 A, and symmetric interrupting ratings up to 63 kA. SF₆ circuit breakers are either the dead tank design, or the live tank design and the GIS design. During recent years SF₆ circuit breakers have reached a high degree of reliability, and they cope with all known switching phenomena.

Their completely closed gas system eliminates any exhaust during switching operations and thus adapts to environmental requirements. They may be installed horizontally or vertically, according to the structural requirements of the substation. The quick dielectric regeneration of the arc plasma in SF₆ makes insertion resistors unnecessary, simplifying the apparatus. Their compact design considerably reduces space requirements and building and installation costs. In addition, SF₆ circuit breakers require very little maintenance.

CIRCUIT BREAKER TIMING TESTS

The timing of a breaker is the time measurement of the mechanical operations in order to verify its integrity and good working order. Mechanical operation means all operation or cycle of operation the breaker is intended to do without being connected to the power grid. It is a necessary to time each breaker, in order to have its functional signature. Incorrect operation can have disastrous consequences on the equipment or the substation personnel. Not to mention the out of service losses of revenue and the repair costs. Timing tests are done first in the factory during the routine tests and after installation, during the commissioning tests. They have to be done periodically in order to validate the good working order and reliability of the breaker. Timing tests are also a powerful tool for troubleshooting faulty breakers.

In order to measure the operation times of a breaker, we need a device capable of detecting the instant of contact's state changing starting from the point the order was launched. This device sends electric signals via cables connected to each contact, in the case of several contacts in series each signal has its own source to eliminate interference. The signal has two possible states. The first is when the contact is closed, the second when the contact is open. All is recorded for consultation and analysis. These special devices are called timing machines or circuit breaker analyzers. They are designed to generate all the needed signals and incorporate a data acquisition system. Four steps constitute the main activities to accomplish a timing test: [2]

1. Cable installation and connection
2. Data Acquisition
3. Data interpretation
4. Data analysis

Installation And Connection

The connection, mainly between the timing machine and the breaker, has to be done correctly taking into account certain external factors, for instance magnetic induction by nearby high voltage transmission lines. Another connection has to take place between the timing machine and the mechanism coils responsible for launching the operation order. Some other connections may also be required as travel transducer, pressure transducer, auxiliary contacts, etc

Each breaker contact has to be verified separately. For multi-contacts per phase, each contact has to have its own verification circuit. Each verification circuit includes a voltage source that injects current on contact making; a detection circuit, to detect the current and determine if the contact is closed; two-wire shielded cable to carry the signal. The timing machine supplies the verification circuits. Each verification circuit is called a channel. The following figure shows an example of how the main contacts are connected to the channels:

For multiple contacts per phase, special care has to be observed to avoid the mirror effect (treated later in this article), where the data for some contacts will be corrupted by the data from other contacts

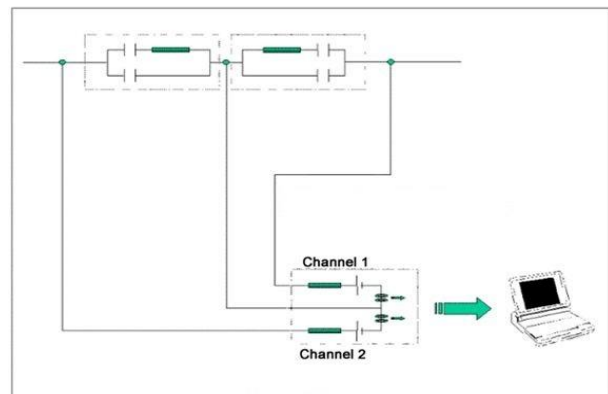

Command Connections

Data Acquisition :

In addition to the signal generation, timing machines are in charge of contact transition detection and recording. The earliest timing machines used light reflected on moving mirrors driven by the current signal coming from the contacts. The light is projected on paper film, thus creating a visible trace. Today, in the computer age, timing machines have undergone a tremendous evolution. They use electronics and computer technology for data acquisition. Powerful software serves to analyze and conserve data for future studies. Data transmission has never been easier. Decisions can be made quickly and accurately.

Data Interpretation :

Many external agents can influence greatly the collection of information. It is important to distinguish in the collected information, between the useful data and the external noise.

Good interpretation is based on three main principals:

Know the circuit breaker and surrounding environment :

Induction due to the proximity of overhead power transmission lines, or a bad cable connection could alter the collected signal.

Know the timing machine:

Incorrect programming or a failed circuit can cause unnoticed signal alteration as well.

Know the significance of the values looked for:

When timing a breaker, we are looking for certain values, such as contact switching times, coil energizing times, etc. that can allow quick identification of a problem, and if a value seems excessive, we can look to it in time and repeat repeat the test before taking all the cables down.

BREAKER OPERATION TIMES

In its description, the circuit breaker is a device that conducts or interrupts currents to the circuit. This is done by mechanically joining or parting two sets of contacts. These are the basic operations of the circuit breaker and are

called "CLOSE" when joining, and "TRIP" when parting the contacts.

As we mentioned before, these are not the only operations that the breaker is meant to do. In most of the cases it has to execute on demand a combination of the basic operations, called cycles. The most popular are the following:

1. "TRIP FREE", (C-O): simulates a trip on short circuit after a "CLOSE". The breaker must open instantly.

2. "RECLOSE", (O-C): simulates a fast close after short circuit trip to re-establish the current.

3. "RECLOSE-OPEN", (O-0.3s-C-O): Simulates RECLOSE on short circuit. The breaker should clear the fault successfully.

4. (C-O)-15 sec-(C-O)-15-sec-(C-O): simulates a multiple close after short circuit trips in purpose of reestablishing the current, hoping that the short circuit is disappeared. This cycle is mostly used in the Medium voltage applications.

The times measured, for the different cycles starting from the coil energizing until the switching of the main contacts are called the Breaker's mechanical times of operations.

TIME REFERENCE

The basis of timing tests is to collect information in order to compare it with reference values. The comparison should be done on comparable parameters. So the collected values should follow the same rules as the reference values, and be independent of individual interpretations.

The IEC 56 international standard defines these times as follows:

a. Opening Time (IEC 56 3.105.32)

For a circuit breaker tripped by any form of auxiliary power, the opening time is the interval of time between the instant of energizing the opening release, the circuit breaker being in the closed position, and the instant when the arcing contacts have separated in all poles.

Notes :

1. The opening time may vary significantly with the breaking current.

2. For circuit breakers with more than one interrupting unit per pole the instant when the arcing contacts have separated in all poles is determined as the instant of contact separation in the first unit of the last pole.

3. The opening time includes the operating time of any auxiliary equipment necessary to open the circuit breaker and forming an integral part of the circuit breaker.

b. Closing Time (IEC 56 3.105.35)

The interval of time between energizing the closing circuit, the circuit breaker being in the open position, and the instant when the contacts touch in all poles.

Note : The closing time includes the operating time of any auxiliary equipment necessary to close the circuit breaker forming an integral part of the circuit breaker.

c. Open-Close Time, O-C or Isolation Time (IEC 563.105.38)

The interval of time between the instant when the arcing contacts have separated in all poles and the instant when the contacts touch in the first pole during a reclosing-operation.

d. Close-Open Time or Short-Circuit Time (IEC 563.105.42)

The interval of time between the instant when the contacts touch in the first pole during a closing operation and the instant when the arcing contacts have separated in all poles during the subsequent opening operation.

Note : Unless otherwise stated, it is assumed that the opening release incorporated in the circuit breaker is energized at the instant when the contacts touch in the first pole during closing. This represents the minimum close-open time.

e. Minimum Trip Duration (IEC 56 3.105.44)

The minimum time the auxiliary power has to be applied to the opening release to ensure complete opening of the circuit breaker.

f. Minimum Close Duration (IEC 56 3.105.45)

The minimum time the auxiliary power has to be applied to the closing device to ensure complete closing of the circuit breaker

DATA ANALYSIS

Data Analysis is the final step of the timing test. The professional in charge has to have good knowledge of both the circuit breaker being timed and the network requirements. Since timing machines, nowadays, incorporate powerful analysis tools, a good knowledge of these tools is very helpful and time saver. The person has to have also a developed analytical sense and to be able to distinguish between the importance of the requested results and the consequences of non-conformity. In addition to the entire above, one of the important factors in good data analysis is always experience.

TIMING CHART

The circuit breaker has to comply with user requirements, in addition to the international standards specifications. The designer takes into account these requirements when designing a particular circuit breaker. The operation time references and tolerances are established, based on tests and a reference table, called a timing chart, is drawn up.

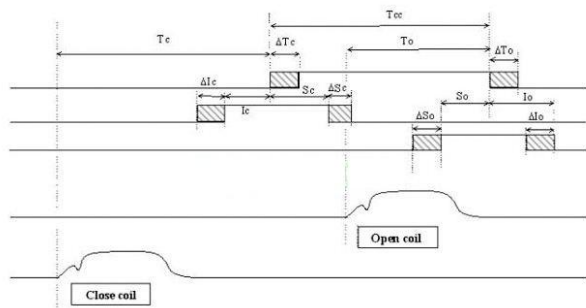

Timing Chart - 1

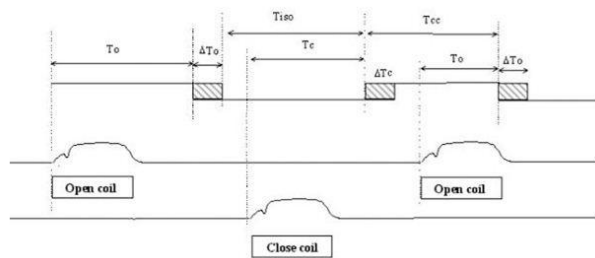

Timing Chart - 2

The timing chart contains time references for all the operation cycles the breaker is meant to accomplish. In addition to these time references, the designer may consider it useful to note other times to insure proper function of the breaker or any of its subassemblies.

Following the data analysis important decisions are to be taken:

1. Put the breaker into service
2. Suspend commissioning operations and take further actions in order to correct any faulty condition.

In the first case, putting an unsuitable breaker in service would have disastrous consequences, either to the equipment or to the maintenance personnel. In the second case, the cost would be enormous if it turned out to be unnecessary as a result of an incorrect analysis. [5]

4.3.1 Priority Levels Of The Operation Times

There remains the question of determining the priorities in order to perform a successful analysis. The priority levels are described from high to low as follows:

a. "Trip" Time

Reducing the duration of short circuit currents on power transmission lines is a permanent objective. The main advantage is higher transmitted power, since the power transmission stability threshold is higher when the short circuit duration is shorter. The user determines the current interruption duration, For example 2 cycles. The duration of the current interruption is counted starting from the instant the main mechanism coil energizes until the final interruption of the current in the main contact, including the arc duration. The interrupting time is then equal to the mechanical time

(operation time) plus the arc duration. For a 50 Hz network, 2.5 cycles are equivalent to $2.5/50 = 0.05 \text{ s} = 50 \text{ ms}$ (ms = milliseconds). Since the timing test is done with the breaker out of circuit (no load), the arc duration is not measurable. The arc duration depends on several factors: voltage level, interrupting medium, interrupting techniques, etc. It is determined during the design testing. The "TRIP" time is then adjusted to obtain the interrupting time. The "TRIP" time is then, first and foremost, a user requirement the designer has accepted to respect. Nevertheless, an inappropriate "TRIP" time may cause important risks of different natures for a longer time or shorter-one.

b. Longer "Trip" Time

Many risks can be caused by a too long "TRIP" time. It can be anything from a simple anomaly in the tripping control circuit to a major failure in the main interrupting circuit. The analysis should take care to examine all details to reach a precise conclusion. Breakers' characteristics play a fundamental role. Listing all probable cases is impossible.

In general, and independently of breaker's type, a longer "TRIP" time can be caused by a slower transition speed, the arc duration may be longer and premature contact wear may take place. For small capacitive currents, the voltage spikes are strong and may cause a consecutive fault. Consecutive faults are line to ground short circuits, consecutive to an interrupting of small capacitive or inductive currents. The breaker that is interrupting a small current sees its current growing instantly to full short circuit current. Some breaker types have difficulty in correcting this situation. A known method to overcome the consecutive fault is to interrupt with high speed breakers. Lower speed can be crucial in this case.

Conclusion: Reduced tripping speed can compromise the operation of the breaker and possibly that of the power network itself, not to mention the risk of consecutive faults.

c. Shorter "Trip" Time

Following a short circuit, the nominal alternating current flowing in the circuit grows instantly to a huge value, of the same nature and frequency called the symmetrical-short-circuit-current

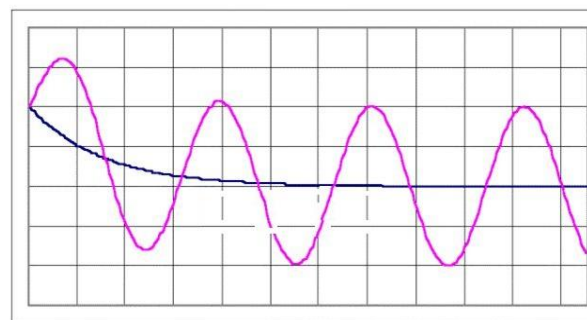

Short circuit current

Due to the network's inductive nature, a temporary DC component adds itself to the symmetrical short circuit value. The result is called an asymmetrical short circuit. The initial value equals the instantaneous value of the symmetrical short circuit at the point of the short circuit with a negative sign. It

decreases afterward, following a damped exponential curve, with a speed determined by the time constant of the circuit.

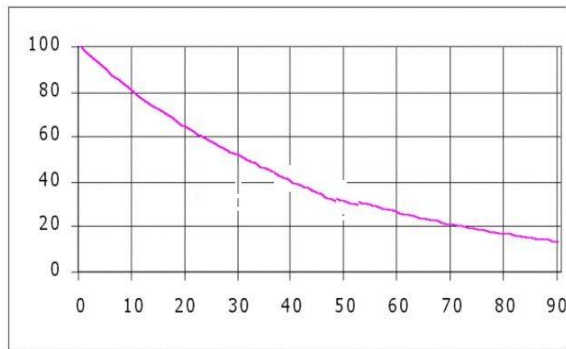

Nominal Value of a periodic component

The breaking capacity of a particular breaker is the highest value of current that breaker is capable of interrupting. The breaker is supposed to interrupt successfully every current equal or less to its breaking capacity, whether the current is symmetrical or asymmetrical. Considering the curve in figure one notes that the asymmetrical value is function of the interrupting time. If it is higher, if the interrupting time is shorter. As a result, if the breaker is too fast the asymmetrical value can exceed its breaking capacity, and breaking is no longer ensured. The curve of figure shows the nominal value of the a periodic component as a function of the opening time of the breaker. This curve uses a damping time of 20% per hundredth of a second.[2]

Conclusion: The "TRIP" time should never be less than the reference value, otherwise the asymmetrical short circuit value can exceed the breaker's breaking capacity.

Contacts Discrepancy:

High voltage breakers are three-phase apparatus. It contains at least one contact per phase, and in some cases, multiple contacts in series per phase, up to 12 per phase for certain air blast breakers at 765 kV. It is crucial for the proper operation of the breaker and of the network to limit the time discrepancy between the contacts. The types of discrepancies can be divided into 2 groups:

a. Contacts Discrepancy Between Poles:

On Trip: According to IEC 56 (parag.3.3.1) the phase is considered open when the first contact of the pole is open. The biggest discrepancy measured should not exceed a maximum value set by the designer, the user, or by an agreement between them. If not conforming: Poles' contacts separation has to be simultaneous to prevent high voltage transients, otherwise it would attain double the rated value on the first parting pole. The maximum discrepancy allowed is 1/6th of a cycle.

On Close: According to IEC 56 (parag.3.3.2) the phase is considered closed when the last contact of the pole is closed. The biggest discrepancy measured should not exceed a

maximum value set by the designer, the user or by an agreement between them. If not conforming: The sudden energizing of circuits is always followed by a moderate voltage increase, with the exception of long, unloaded transmission lines, where the voltage rise can be critically dangerous. When a line is connected to an energized network, a voltage wave is forced on the line. This wave is reflected back at the end of an open line, and returns with double the amplitude. Even higher voltages may be encountered when the line has a load before being reenergized, and if the breaker closes at the moment that the polarity of the network is opposite to that which was present on the line.

The voltage may then be three times the network voltage, after reflection of the wave. This situation may be produced with a rapid reclose of a line. Still higher voltages may be encountered on three-phase lines, when the three poles of the breaker do not close simultaneously. A wave on one phase will produce induced waves in the other phases, and under unfavorable conditions, will increase the voltage on another phase. Higher transition voltage rises can be encountered if the discrepancy on closing is too high. Note that on networks where the nominal voltage is 500 kV and higher, the isolation of the lines is determined by the operation voltage spikes.

b. Discrepancy Between Contacts of the Same Pole

For multiple-contact-per-pole breakers, grading capacitors are installed in parallel with each contact to equalize the voltage when contacts part. In general, the fastest contact has the longest arc duration and higher contact wear. In case of excessive discrepancy, the fastest contact on close and slowest on trip would cause higher voltage shocks to their grading capacitors, thus reducing their life expectancy and that of the contact.

c. "Close" Time

During closing, especially on short circuits, opposite forces are considerable. In case of slow moving contacts the pre-arc has a longer duration thus causing more contact deterioration. If the closing time is not respected, this would compromise the relative guarantee to the closing capacity. This time is usually supplied by the designer of the circuit breaker.

d. Operation Cycles

An operation cycle is a sequence of basic "CLOSE" and "TRIP" operations in specified time intervals. The most common sequences are conform to the following formula:

$$O \rightarrow T \rightarrow CO \rightarrow T' \rightarrow CO$$

O: Trip operation , CO: Trip-Free cycle , T: Time delay of 0.3 seconds or 3 minutes , T': Time delay of 3 minutes

Trip-Free (Co) Cycle, Short Circuit Time

CO cycles simulate closing on a short circuit. In the actual event, the breaker closes first, and then the protection relay system detects the short circuit and trips the breaker. In the test event the timing machine can be programmed to launch a trip command as soon as the contacts close. This gives the fastest short circuit time the breaker is capable of doing. This value is compared with the designer's references.

Reclose-Open (OCO) Cycle, Isolation Time

Experience shows that a great number of short circuits are temporary. It means they are caused by an event that disappears shortly after the breaker opens. A few examples are: short circuits caused by lightning, a bird, fallen trees or branches, etc. The purpose of fast Reclose is to reduce the duration of power interruption. It is important to reduce this duration to a minimum. For the out of service circuit, it is important to give it enough time to clear the fault. In effect, temporary faults create arcs; once the power feeding this arc is cut, enough time needs to pass for the arc plasma to deionize before reconnecting power, or another trip may occur. Statistics show that a 0.3 sec duration between the contacts opening and the contacts closing is enough to achieve this goal. [6]

If on closing another trip occurs, the breaker will have to interrupt the short-circuit a second time. There will have to be a sufficient delay between the interruptions for the interrupting medium to regenerate, so the second interruption will be performed correctly. If the breaker trips a second time, it should remain open. High-voltage transport and interconnecting networks automatic fast reclosing avoids tripping between two interconnected sources. In effect, when breakers on an interconnecting line between two networks trip, there is a rapid loss of phase synchronization if this line is the only one interconnecting them. If there is another line running in parallel, it may trip in turn by overloading, which causes a loss of synchronization.

This de-synchronization may be avoided, when the faults are temporary, by quickly reclosing the breakers before the phase shift becomes too great. If the tripped circuit is three-phase, the reclosing time must be very short, on the order of 0.3 seconds. If the reclose time is longer, there is a risk of closing on a phase discordance.

During timing tests, the O-0.3s-CO test verifies the behavior of the circuit breaker in this particular type of operation. On Reclose-Open timing test event, the timing machine is programmed to delay the closing command until the isolation time of 0.3 seconds is obtained. This delay must not be confused with that of certain type of delaying devices installed on some breakers, even if these times are similar.

CONCLUSION

An accurate analysis makes it possible to make decisions that are profitable to the breaker, the network and to the maintenance personnel. In order to achieve this, knowing the timing machine and the significance of the operating times is important but not enough. Knowing well the breaker itself, the reference values (timing chart) and the network characteristics is necessary. All of this backed with the experience and sense of judgment of the testing personnel

REFERENCES

1. Nimal, R.J.G.R., Hussain, J.H., Effect of deep cryogenic treatment on EN24 steel, *International Journal of Pure and Applied Mathematics*, V-116, I-17 Special Issue, PP-113-116, 2017
2. Parameswari, D., Khanaa, V., Deploying lampont clocks and linked lists, *International Journal of Pharmacy and Technology*, V-8, I-3, PP-17039-17044, 2016
3. Parameswari, D., Khanaa, V., Case for massive multiplayer online role-playing games, *International Journal of Pharmacy and Technology*, V-8, I-3, PP-17404-17409, 2016
4. Parameswari, D., Khanaa, V., Deconstructing model checking with hueddot, *International Journal of Pharmacy and Technology*, V-8, I-3, PP-17370-17375, 2016
5. Parameswari, D., Khanaa, V., The effect of self-learning epistemologies on theory, *International Journal of Pharmacy and Technology*, V-8, I-3, PP-17314-17320, 2016
6. Pavithra, J., Peter, M., GowthamAashirwad, K., A study on business process in IT and systems through extranet, *International Journal of Pure and Applied Mathematics*, V-116, I-19 Special Issue, PP-571-576, 2017
7. Pavithra, J., Ramamoorthy, R., Satyapira Das, S., A report on evaluating the effectiveness of working capital management in googolsoft technologies, Chennai, *International Journal of Pure and Applied Mathematics*, V-116, I-14 Special Issue, PP-129-132, 2017
8. Pavithra, J., Thooyamani, K.P., A cram on consumer behaviour on Mahindra two wheelers in Chennai, *International Journal of Pure and Applied Mathematics*, V-116, I-18 Special Issue, PP-55-57, 2017
9. Pavithra, J., Thooyamani, K.P., Dkhar, K., A study on the air freight customer satisfaction, *International Journal of Pure and Applied Mathematics*, V-116, I-14 Special Issue, PP-179-184, 2017
10. Pavithra, J., Thooyamani, K.P., Dkhar, K., A study on the working capital management of TVS credit services limited, *International Journal of Pure and Applied Mathematics*, V-116, I-14 Special Issue, PP-185-187, 2017
11. Pavithra, J., Thooyamani, K.P., Dkhar, K., A study on the analysis of financial performance with reference to Jeppiaar Cements Pvt Ltd, *International Journal of Pure and Applied*

- Mathematics, V-116, I-14 Special Issue, PP-189-194, 2017
12. Peter, M., Dayakar, P., Gupta, C., A study on employee motivation at Banalari World Cars Pvt Ltd Shillong, International Journal of Pure and Applied Mathematics, V-116, I-18 Special Issue, PP-291-294, 2017
 13. Peter, M., Kausalya, R., A study on capital budgeting with reference to signware technologies, International Journal of Pure and Applied Mathematics, V-116, I-18 Special Issue, PP-71-74, 2017
 14. Peter, M., Kausalya, R., Akash, R., A study on career development with reference to premheerasurgicals, International Journal of Pure and Applied Mathematics, V-116, I-14 Special Issue, PP-415-420, 2017
 15. Peter, M., Kausalya, R., Mohanta, S., A study on awareness about the cost reduction and elimination of waste among employees in life line multispeciality hospital, International Journal of Pure and Applied Mathematics, V-116, I-14 Special Issue, PP-287-293, 2017
 16. Peter, M., Srinivasan, V., Vignesh, A., A study on working capital management at deccan Finance Pvt Limited Chennai, International Journal of Pure and Applied Mathematics, V-116, I-14 Special Issue, PP-255-260, 2017
 17. Peter, M., Thooyamani, K.P., Srinivasan, V., A study on performance of the commodity market based on technicalanalysis, International Journal of Pure and Applied Mathematics, V-116, I-18 Special Issue, PP-99-103, 2017
 18. Philomina, S., Karthik, B., Wi-Fi energy meter implementation using embedded linux in ARM 9, Middle - East Journal of Scientific Research, V-20, I-12, PP-2434-2438, 2014
 19. Philomina, S., Subbulakshmi, K., Efficient wireless message transfer system, International Journal of Pure and Applied Mathematics, V-116, I-20 Special Issue, PP-289-293, 2017
 20. Philomina, S., Subbulakshmi, K., Ignition system for vechiles on the basis of GSM, International Journal of Pure and Applied Mathematics, V-116, I-20 Special Issue, PP-283-286, 2017
 21. Philomina, S., Subbulakshmi, K., Avoidance of fire accident by wireless sensor network, International Journal of Pure and Applied Mathematics, V-116, I-20 Special Issue, PP-295-299, 2017
 22. Pothumani, S., Anuradha, C., Monitoring android mobiles in an industry, International Journal of Pure and Applied Mathematics, V-116, I-20 Special Issue, PP-537-540, 2017
 23. Pothumani, S., Anuradha, C., Decoy method on various environments - A survey, International Journal of Pure and Applied Mathematics, V-116, I-10 Special Issue, PP-197-199, 2017
 24. Pothumani, S., Anuradha, C., Priya, N., Study on apple iCloud, International Journal of Pure and Applied Mathematics, V-116, I-8 Special Issue, PP-389-391, 2017
 25. Pothumani, S., Hameed Hussain, J., A novel economic framework for cloud and grid computing, International Journal of Pure and Applied Mathematics, V-116, I-13 Special Issue, PP-5-8, 2017
 26. Pothumani, S., Hameed Hussain, J., A novel method to manage network requirements, International Journal of Pure and Applied Mathematics, V-116, I-13 Special Issue, PP-9-15, 2017
 27. Pradeep, R., Vikram, C.J., Naveenchandra, P., Experimental evaluation and finite element analysis of composite leaf spring for automotive vehicle, Middle - East Journal of Scientific Research, V-12, I-12, PP-1750-1753, 2012
 28. Prakash, S., Jayalakshmi, V., Power quality improvement using matrix converter, International Journal of Pure and Applied Mathematics, V-116, I-19 Special Issue, PP-95-98, 2017
 29. Prakash, S., Jayalakshmi, V., Power quality analysis & power system study in high voltage systems, International Journal of Pure and Applied Mathematics, V-116, I-19 Special Issue, PP-47-52, 2017
 30. Prakash, S., Sherine, S., Control of BLDC motor powered electric vehicle using indirect vector control and sliding mode observer, International Journal of Pure and Applied Mathematics, V-116, I-19 Special Issue, PP-295-299, 2017
 31. Prakesh, S., Sherine, S., Forecasting methodologies of solar resource and PV power for smart grid energy management, International Journal of Pure and Applied Mathematics, V-116, I-18 Special Issue, PP-313-317, 2017
 32. Prasanna, D., Arulselvi, S., Decoupling smalltalk from rpcs in access points, International Journal of Pure and Applied Mathematics, V-116, I-16 Special Issue, PP-1-4, 2017

33. Prasanna, D., Arulselvi, S., Exploring gigabit switches and journaling file systems, *International Journal of Pure and Applied Mathematics*, V-116, I-16 Special Issue, PP-13-17, 2017
34. Prasanna, D., Arulselvi, S., Collaborative configurations for wireless sensor networks systems, *International Journal of Pure and Applied Mathematics*, V-116, I-15 Special Issue, PP-577-581, 2017
35. Priya, N., Anuradha, C., Kavitha, R., Li-Fi science transmission of knowledge by way of light, *International Journal of Pure and Applied Mathematics*, V-116, I-9 Special Issue, PP-285-290, 2017
36. Priya, N., Pothumani, S., Kavitha, R., Merging of e-commerce and e-market-a novel approach, *International Journal of Pure and Applied Mathematics*, V-116, I-9 Special Issue, PP-313-316, 2017
37. Raj, R.M., Karthik, B., Effective demining based on statistical modeling for detecting thermal infrared, *International Journal of Pure and Applied Mathematics*, V-116, I-20 Special Issue, PP-273-276, 2017
38. Raj, R.M., Karthik, B., Energy sag mitigation for chopper, *International Journal of Pure and Applied Mathematics*, V-116, I-20 Special Issue, PP-267-270, 2017
39. Raj, R.M., Karthik, B., Efficient survey in CDMA system on the basis of error revealing, *International Journal of Pure and Applied Mathematics*, V-116, I-20 Special Issue, PP-279-281, 2017
40. Rajasulochana, P., Krishnamoorthy, P., Ramesh Babu, P., Datta, R., Innovative business modeling towards sustainable E-Health applications, *International Journal of Pharmacy and Technology*, V-4, I-4, PP-4898-4904, 2012
41. Rama, A., Nalini, C., Shanthi, E., An iris based authentication system by eye localization, *International Journal of Pharmacy and Technology*, V-8, I-4, PP-23973-23980, 2016
42. Rama, A., Nalini, C., Shanthi, E., Effective collaborative target tracking in wireless sensor networks, *International Journal of Pharmacy and Technology*, V-8, I-4, PP-23981-23986, 2016
43. Ramamoorthy, R., Kanagasabai, V., Irshad Khan, S., Budget and budgetary control, *International Journal of Pure and Applied Mathematics*, V-116, I-20 Special Issue, PP-189-191, 2017
44. Ramamoorthy, R., Kanagasabai, V., Jivandan, S., A study on training and development process at Vantec Logistics India Pvt Ltd, *International Journal of Pure and Applied Mathematics*, V-116, I-14 Special Issue, PP-201-207, 2017.
45. Pradeep, R., Vikram, C.J., Naveenchandran, P., Experimental evaluation and finite element analysis of composite leaf spring for automotive vehicle, *Middle - East Journal of Scientific Research*, V-17, I-12, PP-1760-1763, 2013

