

Intelligent Energy Saving System using Real-Time Moving Object Detection and Microcontroller Unit

NORMA J. APAO

<http://orcid.org/0000-0002-1600-4108>
njapao@universityofbohol.edu.ph

VICTOR JOHN L. ANUNCIADO

<http://orcid.org/0000-0003-4519-4702>
vjanunciado@gmail.com

ABSTRACT

Intelligent Energy Saving System is a technologically advanced system that combines hardware and software to perceive and interact with the physical environment for saving electrical energy. Many times, students and teachers leave the classroom without switching off the lights and fans, thus electricity is wasted. This paper assesses the number of instances in a week the lights and fans are switched ON without room occupants in the 14 classrooms of the Achievers and Founders Buildings in the University of Bohol. Moreover, this paper gives importance to energy conservation inside the classroom by way of developing and recommending an automated energy saving system that utilizes a real-time moving object detection approach and microcontroller unit to sense and control objects in the classroom focusing on the automatic control of lights and fans to reduce energy consumption. The study employed the developmental research method and applied a quantitative approach utilizing the direct and structured observation method in gathering the data. Frequency and ranking were the data treatment used to data collected. The findings of this study revealed that there are at least 25 times in a week where the lights were left ON and at least 55 times in a week where the fans were left ON without anyone in the classroom. The

proposed intelligent energy saving system has favorable and consistent laboratory results wherein it was shown that the system can detect human presence and control the operation of the fans and lights. Through this system, the authors wish to contribute in minimizing electricity consumption and help academic institutions save on their electricity bills.

Keywords: Intelligent energy saving system, image detection, microcontroller, Arduino Uno board

INTRODUCTION

Energy conservation is the effort to lessen energy consumption by reducing the number of services used or by using energy more efficiently. Conserving electricity gives numerous benefits to the consumer, nation and the environment. Energy-saving strategies can help save energy and money, improve our economy, and help stop global warming. One of the easiest ways to help reduce energy consumption is to use electronic products only when necessary.

Energy costs are a huge part of the school's expenditures. Hence, the school administrators are tracking the energy usage and imploring everyone to do their share of conserving energy like using the air-conditioned units only from 9:00AM to 5:00PM; turning off lights in unoccupied rooms; turning off computers when not in use; and incorporating energy-efficient equipment. Making behavioral and operational changes in school has resulted in some energy savings. Changing a user's daily habits in using electricity has a good impact in day-to-day life and to the environment. However, some people cannot simply turn the lights and fans off before leaving a room. The reminders and stickers saying to do this seem invisible to those who do not care. This misuse of electricity sees the need for an intervention or solution to minimize energy consumption. Thus, an intelligent energy saving system needs to be installed in the university; a smart system that requires no human intervention and allows automatic control of devices such as lights and fans.

This study implements a technology that detects the human presence in a particular area and manages the electrical supply of the two electrical products under consideration. This proposed energy-saving architecture is beneficial not only in the classrooms but also in boarding houses and conference halls where users would usually leave a place without switching

off the lights and fans. In this proposed system, when a person enters the room, the lights will be switched ON and the average room temperature is measured. The fans will only be activated if and only if the room temperature is beyond the temperature set beforehand. It will then automatically adjust the fan speed based on the obtained average of the room temperature. Conversely, if nobody is present in the room or hall, the lights and fans will be automatically switched off. The Impact of Saving Electricity in the Environment

Related Studies

According to a study by Shri and Nirmala (2016), power wastages have most commonly occurred in schools and colleges where the fans and lights are kept ON even if there is nobody in the classroom due to the carelessness or negligence of the students. This statement is supported by the study of Sujana, Ramesh, & Reddy (2011) which indicated that most people in public and private companies are not interested in switching OFF the consumer electronic appliances like fans and lights.

As more and more electronic products are developed and installed, the need for power is increasing rapidly. Dasthagiraiah, Manohar, Naik, Srinivasulu, Reddy, & Kumar (2013) theorized that rapid development has brought a wide variety of available electronic appliances, but the requisite energy sources exploitation has become a serious problem. With the advent of ever-increasing electricity bills, there is a need to efficiently regulate power consumption to reduce its overbearing cost effect (Adegoke, Akinyele, & Bakare, 2015). Efficient power strategies for a classroom, offices or home are significantly required to lessen energy or power consumption also knowing that the renewable and non-renewable electricity generation is insufficient. (Albers, 2010) in her article entitled "Energy-Efficient Algorithms", stated that energy conservation is a primary concern today and further indicated that federal programs provide programs to save energy and promote the use of renewable energy resources.

To overcome the problem of the wastage in electricity and to increase energy awareness, several ideas and studies have been conducted and proposed. Selected studies are presented in this section.

Gogulapriya and Palanivelu (2016) designed a system that automates the monitoring of the personnel's physical presence in an office and turns off the power in their absence. The study proposed an algorithm for detecting a particular object based on finding point correspondences between the

reference and the target image which can detect objects despite scale change or in-plane rotation. The study concluded that object detection works best for objects that exhibit non-repeating texture patterns, which give rise to unique feature matches. The study further found that the technique is not likely to work well for uniformly-colored objects, or for objects containing repeating patterns and detects the presence of human inside the room with high efficiency .

Zhou and Huang (2015) conducted an Experimental Study of Energy Saving Potential in Mixing and Displacement Ventilation with Wireless Sensor Networks. The findings of the study revealed that the application of the Wireless Sensor Networks (WSN) in room temperature control could reduce energy consumption by the HVAC system as well as improve thermal comfort. The findings of the study further revealed that a reduction in the supply airflow rate could lead to a reduction in energy consumption of the whole air-conditioning system. The study recommended that for real application, the temperature sensors for space temperature control should be installed in the occupied level rather than in the return air channel.

Mishra, Raza, Zulquarnain & Kumar (2013) conducted a study on the Development of Automatic Person Detection System to Control AC Fan and Room Lights. The output of the study is a system that uses a microcontroller that takes over the task of controlling the room lights. When somebody enters into the museum, the light is automatically switched ON, and the system monitors the number of people entering and leaving the museum. The system also has a function of controlling the fan speed of an electric fan according to the requirement of the scheme. The system uses PIC microcontroller and relays to control the room light and a temperature sensor that senses the temperature and gives control commands to the microcontroller whether to increase or decrease the fan speed.

In the area of Intelligent Systems, smart homes are now becoming a prevalent practice in designing houses where electrical appliances are now hooked up to a computer system. With home automation, the user will no longer be depending on the normal activation of the appliances instead these are controlled remotely by computer programs.

In the study entitled, Ultrasonic Sensor-Based Smart Fan, it was stated that a smart fan is essential to the concept of smart homes. The study developed a circuit which tracks the presence of a person in a room. With the use of an ultrasonic sensor, the study measures the distance between the human and based on the pre-defined set points the speed of the fan

is adjusted (Halder, 2015). One study states that the conventional way of switching OFF lights for a period to save cost comes with some discomfort (Adegoke, Akinyele, & Bakare, 2015).

Another study presents a novel method for human detection that is applied to the automatic control of home appliances power consumption. The study uses a wireless smart outlet network and changes of Received Signal Strength Indicator (RSSI) or Passive Infrared Sensor (PIR) between stationary communication nodes (2.4 GHz smart shops). The main idea of the study is to monitor the changes of PIR/RSSI which violate the established radio communication field between nodes inside a room, due to a human's presence. When a person enters into the established radio communication field, he or she induces the change of the sensor which is periodically read during the message exchange between wireless nodes. Based on the detected changes concerning the initial thresholds, the system detects human presence and responds to the automatic control of power consumption of all appliances connected to the power network. (Dasthagiraiah, et al., 2013).

These aforementioned readings were of great help in giving substance and direction to the study. The studies cited above provide a sketch of the development of intelligent energy saving system.

METHODOLOGY

The study employed the descriptive-normative and developmental research methods to achieve the purpose of the study. This study used the quantitative paradigm utilizing the direct and structured observation method. This study was conducted at the University of Bohol located at Dr. Cecilio Putong Street, Tagbilaran City, Bohol. The 14 classrooms in the two buildings in the university were observed to determine the number of instances wherein the lights or fans were not turned off despite the absence of human presence in the classroom. The classrooms were observed for two weeks: during a regular class week and an examination week. Observation was done twice per observation period from 7:30AM until 7:30PM. An observation matrix was used in recording the observed data gathered that includes the room number, observation period, and the number of times or instances where the lights or fans are left on without somebody in the classroom. Data gathered from this study were analyzed using frequency and rank. A laboratory test matrix was used to tally the laboratory test results of the system.

Prototype Development

The design of the conventional wall and rotating fans used in the classrooms are not altered. The only thing added is the control system with camera and temperature sensor to achieve the goal of this study. In this study, when a person enters the classroom and the motion is detected by the camera, the lights will be switched ON and the average room temperature is measured. The fans will only be activated if and only if the room temperature is beyond the temperature being set. It will then automatically adjust the fan speed based on the obtained average room temperature.

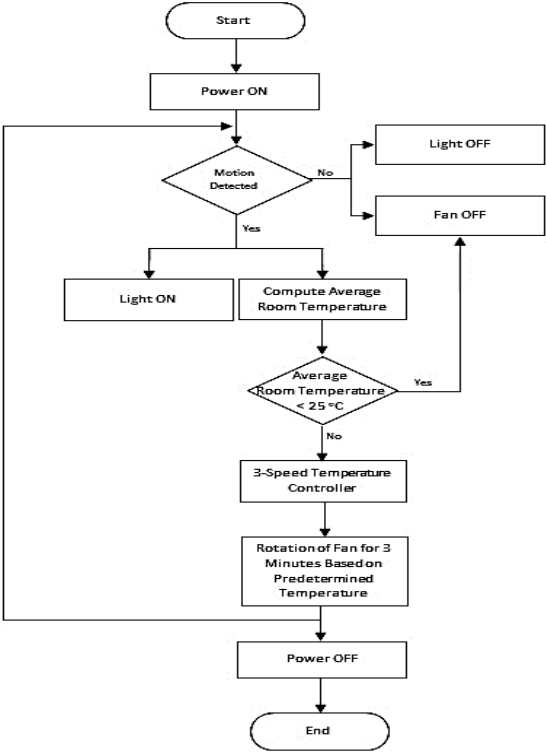

Fig. 1. Intelligent Energy Saving System operating principle

Figure 1 illustrates the operating principle of the proposed system. In this study, when a person enters the classroom, lights are automatically

switched on and the average room temperature is measured. The fans will only be activated if and only if the room temperature is beyond the set temperature or greater than 25°C. It will then adjust the fan speed based on the obtained average room temperature. The minimum or maximum range of temperature for the low, medium or high speed can be set in the system. Figure 2 shows the circuit diagram of the system where the control system and temperature sensor are integrated.

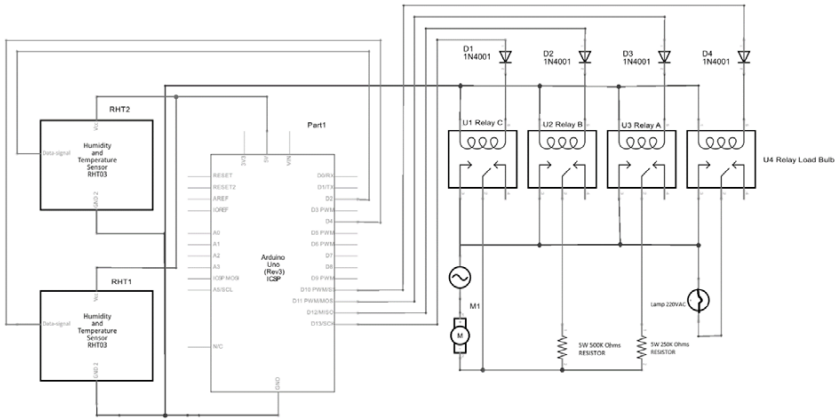

Fig. 2. Schematic Diagram of the system

Microcontroller

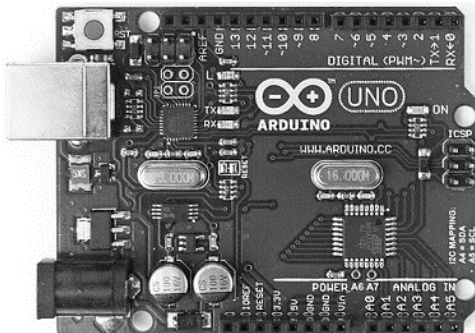

Fig. 3. Arduino Uno Board

The control circuit of the system is designed using Arduino Uno micro-controller that serves as the brain of the system. It is responsible for processing the data sensed in the classroom.

Temperature and Humidity Sensor

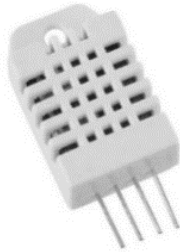

Fig. 4. Temperature and Humidity Sensor

The temperature and humidity sensor reads the classroom's temperature and converts it to a form that can be understood by the microcontroller.

USB Camera



Fig. 5. USB Camera

The camera is used to monitor and detect human presence in the classroom. For moving object detection, this study implements the background model and determine the differences between two consecutive image frames and perform moving object detection based on the differences.

RESULTS AND DISCUSSION

The 14 classrooms in the Achievers and Founders buildings were observed from 7:30AM until 7:30PM on an hourly basis to determine the number of instances the lights and fans of the classroom were left ON without human presence. The results of the data were gathered as well as the laboratory testing results of the proposed intelligent energy saving system are presented in this section.

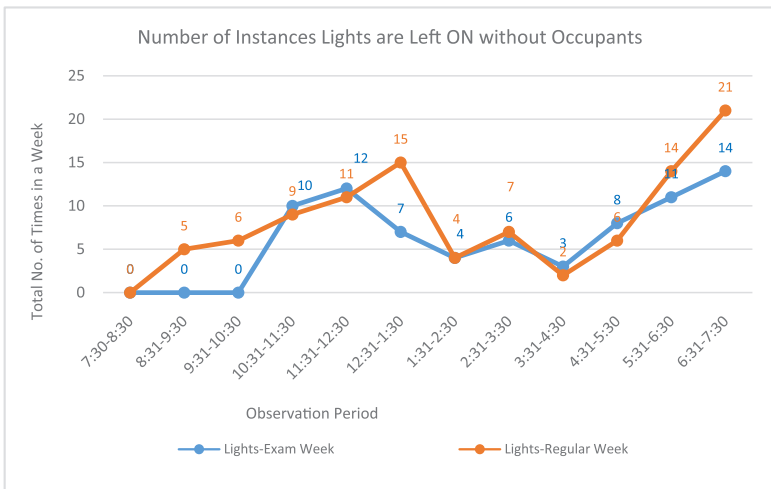

Fig. 6. Comparison between the number of instances lights are left ON during exam week and regular week of classes

Figure 6 shows that in a regular week, the number of unattended lights increased greatly starting 9:30 AM until the noontime period. However, it went down from 1:31PM to 4:30PM and then, rapidly went up again from 4:31PM to 6:31PM. The chart shows that there are more lights that are left ON without classroom occupants during a regular week compared to an examination week.

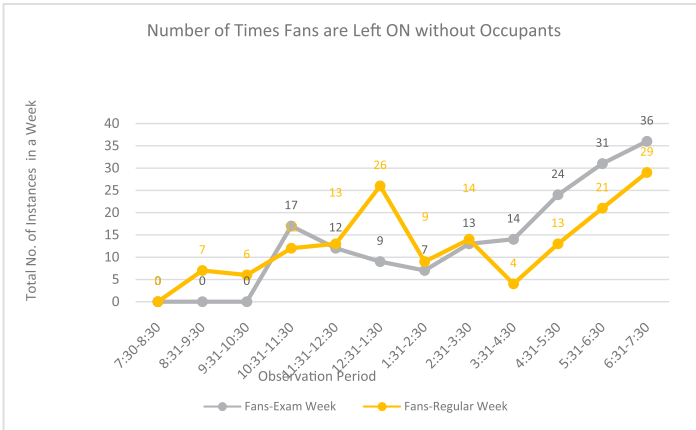

Fig. 7. Comparison between the number of instances fans are left ON during exam week and regular week of classes

Figure 7 illustrates that during a regular week, the number of instances for unattended fans stood at 26 at 12:31PM - 1:30 PM. This number gradually decreases to nine by 1:31PM - 2:30 PM and then climbed abruptly at 4:31PM - 5:30 PM. The chart further illustrates that there are more fans left ON without classroom occupants during an examination week than a regular week of classes.

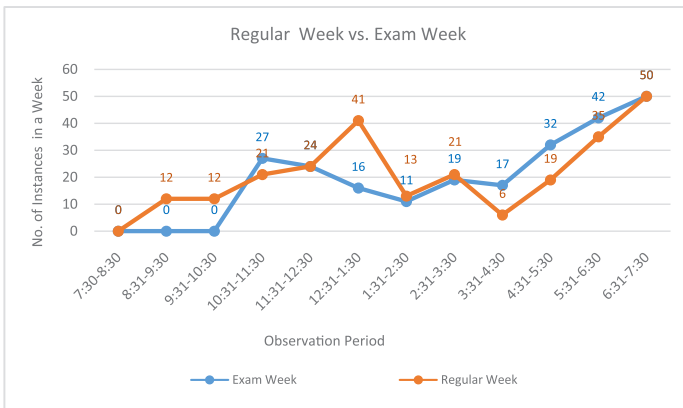

Fig. 8. Comparison between the number of instances lights and fans are left ON during exam week and regular week of classes

Figure 8 compares the number of times the fans and lights are left unattended during exam week and regular week. The chart shows that the numbers both for the exam and regular week climbed sharply from 9:31AM to 1:30 PM and then, slowly decreased beginning at 1:31PM in the afternoon. Then, the number gradually increased from 4:31PM - 5:30 PM period until 6:31PM - 7:30 PM. The most noticeable trend in the chart is that the fans and lights are left unattended from 4:31PM until 7:30PM.

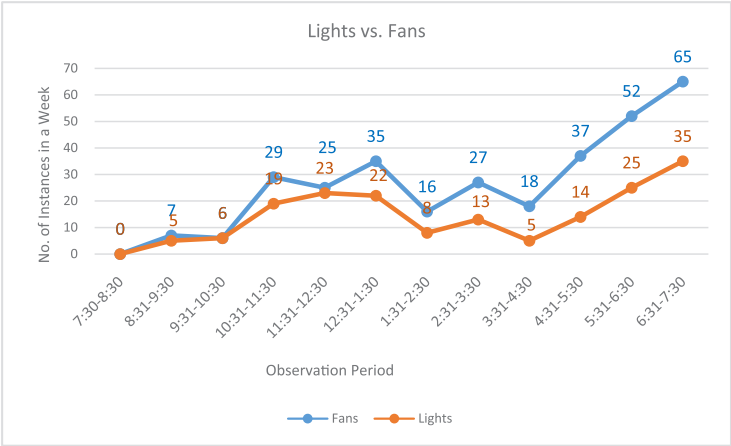

Fig. 9. Comparison between fans and lights on the number of instances these electronic products are left ON without occupants

The chart in Figure 9 compares the number of instances wherein the lights and fans in the classrooms in the two buildings were left ON even if there is nobody in the classrooms. The chart depicts that the fans have more instances wherein they are left unattended compared to the lights. The fans left ON show a significant difference in numbers compared to the number of lights left ON. Fans left ON spiked during 12:31PM - 1:30PM and 6:31PM - 7:30PM.

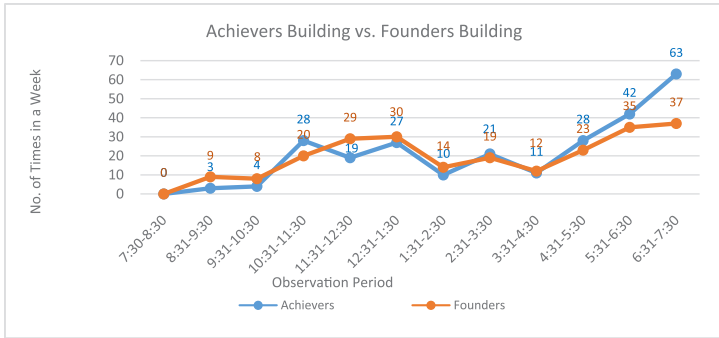

Figure 10. Comparison between Achievers Building and Founders Building on the number of instances electronic products are left on without occupants

The line graph in Figure10 describes the comparison between the wastage of electricity in the Achievers Bldg. and the Founders Bldg. due to the unattended fans and lights. The chart illustrates that there are two peak periods: from 12:31PM - 1:30PM and 6:31PM - 7:30PM. The chart illustrates that in the Achievers building, the number sharply increases during the periods from 4:31PM - 5:30PM and 6:31PM - 7:30PM in the evening. It also shows that the Achievers Building has more instances wherein the lights and fans are left ON without occupants in the classrooms than the Founders Building.

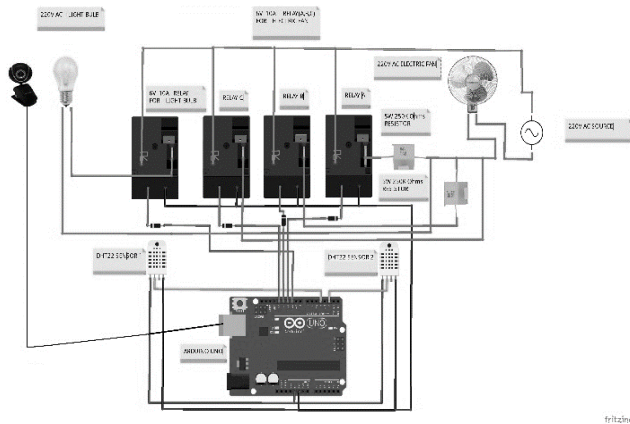

Fig. 11. Schematic diagram of the proposed Energy Saving System

Figure 11 shows how the components of the system interact with the different processes. When the camera detects a motion, lights are switched on and passes data to the Arduino. When the Arduino receives the data, it activates the DHT22 humidity and temperature sensor to sense the room temperature. The sensed room temperature is passed to the Arduino to calculate the average room temperature. The fan is switched on if the average room temperature is greater than 25oC. The fan speed will then automatically be adjusted based on the temperature ranges set in the system.

Table 1. System Testing Results

Test Condition	Expected Result	Actual Result		
		Trial 1	Trial 2	Trial 3
No presence of human	Lights and Fans OFF	S	S	S
Human presence	Lights will turn ON	S	S	S
Room Temperature < 25 degree Celsius	Fans OFF	S	S	S
Room Temperature = 26 up to 28.99 degree Celsius	Fans ON = Level 1	S	S	S
Room Temperature = 29 up to 31.99 degree Celsius	Fans ON = Level 2	S	S	S
Room Temperature > 31.99 degree Celsius	Fans ON = Level 3	S	S	S

Legend: S= Successful

Table 1 exhibits the results of the laboratory tests done on the system to check its functionality and assess its system performance. Each test condition should meet a consistent expected result indicated on the table. During the lab test, the system had successful results for each of the following conditions stated in the first column of the table

CONCLUSION

It can be concluded that there is a wastage of power in the classrooms every day. Furthermore, the results showed that there were more fans that were left ON compared to lights; there were more lights and fans that were left ON without occupants during a regular week of classes as compared to an examination week; and there were more lights and fans

that were left ON without occupants in the Achievers Building compared to the Founders Building. The proposed intelligent energy saving system is an appropriate tool to lessen the power wastage in the classrooms. If this system will be implemented, the wasted electricity in each classroom will be greatly minimized if not eliminated. It would also contribute to a large amount of energy savings. The system would be very suitable for the classrooms in the university since the lights and fans share a common power switch.

RECOMMENDATION

The university should implement and deploy the intelligent energy saving system to minimize the wastage of electricity in the classrooms. In the meantime, it should assign or designate personnel to check or monitor the usage of fans and lights in every classroom while the proposed system is not yet deployed.

REFERENCES

- Adegoke, A. S., Akinyele, A. O., & Bakare, S. O. (2015). Implementation of an intelligent energy saving system. *European Journal of Engineering and Technology Vol, 3*(5). Retrieved from <https://goo.gl/WggCRK>, (accessed last 29 December 2016).
- Albers, S. (2010), "Energy Efficient Algorithms", Communication of the ACN, Vol. 53, Issue 5. Retrieved from <https://goo.gl/wFS7dx>, (accessed last 15 January 2017).
- Dasthagiraiah, A., Manohar, M., Naik, P. B., Srinivasulu, D., Reddy, A. L., & KumarM, G. K. A Human Detection Method for Automatic Control of Power Consumption by Using Zigbee RSSI Changes. *International Journal of Computational Engineering Research (ijceronline.com)*, 3(2). Retrieved from <https://goo.gl/6rUJazz>, (accessed last 20 December 2016).
- Gogulapriya, S. and Palanivelu L.M. (2016), "Automatic Object Detection and EnergyConservation", (IJARBEST) Vol. 2, Special Issue 10, ISSN: 2395-695X. Retrieved from <https://goo.gl/R2qAo9>, (accessed last 15 December 2016).

- Halder, A. B. (2015). Ultrasonic Sensor Based Smart Fan. *International Journal of Advanced Research in Electrical, Electronics and Instrumentation Engineering*, 04(07), 5837-5843. Retrieved from <https://goo.gl/7EcyKZ>, (accessed last 6 January 2017).
- Mishra, R., Raza, S., Zulquarnain, R. A., & Kumar, P. (2013). Development of automatic person detection system to control Ac fan and room lights. *International Journal of Innovative Research in Science, Engineering and Technology*, 2(3). Retrieved from <https://goo.gl/TcT25v>, (accessed last 2 January 2017).
- Roy, A. Shinde, S. & Kang K. (2009), "An Approach for Efficient Real Time Moving Object Detection", Department of Computer Science, Watson School of Engineering and Applied Sciences, Binghamton, NY 13902. Retrieved from <https://goo.gl/qf73Ub>, (accessed last 15 December 2016).
- Shri, A. and Nirmala S. (2016), "Design of an Intelligent Classroom Energy Saving System Using TIVA C Series Microcontroller", (IJARTET) Vol. 3, Special Issue 2, ISSN: 2394-3785. Retrieved from <https://goo.gl/kUHeuz>, (accessed last 9 January 2017).
- Sujana, C., Ramesh, A. P., & Reddy, P. G. (2011). Automatic detection of human and Energy saving based on Zigbee Communication. *International journal on computerscience and engineering*, 3(6), 2346-2353. Retrieved from <https://goo.gl/8AjiEp>, (accessed last 12 December 2016).
- Zhou, P. and Huang G. (2015). "Experimental Study of Energy Saving Potential in Mixing and Displacement Ventilation with Wireless Sensor Networks", (ELSEVIER) 121(2015) 1497-15. Retrieved from <https://goo.gl/h99cKk>, (accessed last 12 December 2016).