

[Type text]

FAULT TOLERANT MODEL PREDICTIVE CONTROL OF OPEN CHANNELS

Klaudia Horváth¹
Joaquim Blesa²
Eric Duviella³
Karine Chuquet⁴

ABSTRACT

Automated control of water systems (irrigation canals, navigation canals, rivers etc.) relies on the measured data. The control action is calculated, in case of feedback controller, directly from the on-line measured data. If the measured data is corrupted, the calculated control action will have a different effect than it is desired. Therefore, it is crucial that the feedback controller receives good quality measurement data. On-line fault detection techniques can be applied in order to detect the faulty data and correct it. After the detection and correction of the sensor data, the controller should be able to still maintain the set point of the system.

In this paper this principle using the sensor fault masking is applied to model predictive control of open channels. A case study of a reach of the northwest of the inland navigation network of France is presented. Model predictive control and water level sensor masking is applied.

INTRODUCTION

The last decades different automatic control strategies have been proposed for open channels management (Malaterre 1995). These strategies benefit from data provided by sensors and actuators connected to SCADA systems to provide more accurate control than manual operation. However, automatic control can be affected by faults in sensors and/or actuators. Hence it is crucial to detect and isolate these possible faults in order to avoid the possible effects of these faults in the behavior of the controlled system. Last years different works that deal with the problem of fault detection and isolation have been published (Blesa et al. (2010), Bedjaoui and Weyer (2011), Pocher et al. (2012), Nabais et al. (2013), Akhenak et al. (2013) and Horváth et al. (2014a)). Once the fault has been detected and isolated the fault can be accommodated in such a way that its effect is minimized in the controlled system using fault tolerant control (FTC) strategies (see Zhang and Jiang (2008)). The FTC strategies can be divided in two types: passive (PFTCS) and active (AFTCS). In PFTCS, controllers are fixed and are designed to be robust against a class of presumed faults. This approach needs neither FDI schemes nor controller reconfiguration, but it has limited fault-tolerant capabilities. In contrast to

¹ Post doctoral researcher at École des Mines de Douai, Bd. Lahure 764, Douai, 59500, France. Current position: post doctoral researcher at Incas3, Dr. Nassaulaan 9, Assen, 9401 HJ, The Netherlands. klaudia.horvath@mines-douai.fr

² Institut de Robòtica I Informàtica Industrial (CSIC-UPC). Carrer Llorens Artigas, 4-6, 08028 Barcelona, Spain. joaquim.blesa@upc.edu

³ École des Mines de Douai, Bd. Lahure 764, Douai, 59500 eric.duviella@mines-douai.fr

⁴ VNF - Service de la navigation du Nord Pas-de-Calais, 37 rue du Plat, 59034 Lille Cedex, France. Karine.chuquet@vnf.fr

PFTCS, AFTCS react to the system component failures actively by reconfiguring control actions so that the stability and acceptable performance of the entire system can be maintained.

This work deals with the problem of level sensor faults when using a MPC controller and an AFTCS strategy to maintain the level in an Inland Navigation as close as possible to the optimal reference called the Normal Navigation Level (NNL) in the presence of sensor faults. In particular, sensor faults are detected and isolated using model-based set-membership techniques (Milanese et al., 1996) that evaluate the available measurements with estimations provided by interval models that consider possible mismatches between the real system and ideal mathematical model by means of uncertainty in parameters and additive error. If the measurements are not inside the interval output of the set-membership model a fault is proved to be in the system. These techniques have been demonstrated to be efficient for fault detection in open flow channels (Blesa et al. 2010). In this work, the fault detection is combined with control: once a fault has been detected, the magnitude of this fault can be estimated using a nominal model. This information is used for the masking sensor AFTCS technique described in (Wu et al. 2006). The corrected measurements with the fault estimation are sent to the Model Predictive Control scheme that uses the information of the sensors to compute the actuator actions to maintain as close as possible the levels of the open flow channel to the setpoint.

The structure of the paper is the following. In section Methodology first the basic ideas of model based fault detection is presented including the model for fault detection, then the model predictive control described briefly including modeling. In the Application section the case study is presented, and then in the last section results are shown and discussed and finally in the Conclusion section the paper is concluded.

METHODOLOGY

Model based fault detection

Model based fault detection is based on the comparison of the measured values and the modeled ones. A mathematical model of the system is established and run in real time. The output of the model is compared to the measured values. If the two results are not consistent a fault is detected. However, the difference between the modeled and measured values can be due to the model error or other unknown uncertainties. In order to take into account possible mismatches between the model and the real system to be monitored an interval model can be used, by having a certain uncertainty bound in each model parameter and in additive error.

Interval models

Let us assume that the system to be monitored can be modeled using a model which is linear in the parameters that can be expressed in discrete time regressor form, Moving Average (MA) model as follows:

$$y(k) = \boldsymbol{\varphi}(k, \tau)\boldsymbol{\theta} + e(k) = \hat{y}(k) + e(k) \quad (1)$$

where

- $\varphi(k, \tau)$ is the regressor vector of dimension $1 \times n_\theta$ which can contain any function of inputs $\mathbf{u}(k)$ and output $y(k)$.
- τ is the transport delay that is unknown but belong to a set of natural numbers:
with $\tau^0, \lambda_\tau \in \mathbb{N}$ and $\tau^0 > \lambda_\tau$, λ_τ being the uncertainty on the time delay.
- $\theta \in \Theta$ is the parameter vector of dimension $n_\theta \times 1$.
- Θ is the set that bounds parameter values. In particular, for interval models, the set of uncertain parameters is bounded by an interval box centered in the nominal parameter values:

$$\Theta \triangleq [\underline{\theta}_1, \bar{\theta}_1] \times \dots \times [\underline{\theta}_{n_\theta}, \bar{\theta}_{n_\theta}]$$

where:

$$\underline{\theta}_i \triangleq \theta_i^0 - \lambda_i \quad ; \quad \bar{\theta}_i \triangleq \theta_i^0 + \lambda_i \quad i=1, \dots, n_\theta, \text{ being } \theta_i^0 \text{ the nominal parameter values;}$$

- $e(k)$ is the additive error bounded by a constant σ such that: $|e(k)| \leq \sigma$.

The parameter set Θ and additive error bound σ are calibrated using fault-free data from the system (rich enough regarding the identification point of view) and in such a way that all measured data in a fault-free scenario will be covered by the interval predicted output produced by using model (1), that is

$$y(k) \in [\underline{\hat{y}}(k) - \sigma, \bar{\hat{y}}(k) + \sigma] \quad (2)$$

where

$$\begin{aligned} \bar{\hat{y}}(k) &= \max_{\theta \in \Theta, \tau \in \{\tau^0 - \lambda_\tau, \tau^0 - \lambda_\tau + 1, \dots, \tau^0 + \lambda_\tau\}} (\varphi(k, \tau) \theta) \\ \underline{\hat{y}}(k) &= \min_{\theta \in \Theta, \tau \in \{\tau^0 - \lambda_\tau, \tau^0 - \lambda_\tau + 1, \dots, \tau^0 + \lambda_\tau\}} (\varphi(k, \tau) \theta) \end{aligned} \quad (3)$$

One of the key points in model based fault detection is how models are built and their uncertainty is estimated. The structure of the model, determined by $\varphi(k, \tau)$ and θ , nominal parameters θ^0 and nominal transport delay τ^0 can be obtained by the physical knowledge of the system or by conventional identification techniques (Ljung, 1999). The additive error bound σ can be computed by a noise study. The delay uncertainty λ_τ can be determined considering that the input process signal is white noise and carrying out the study of the independence between the input and output process signals using confidence intervals (usually, 99% or 95%). On the other hand, given N measurements of outputs and inputs from a scenario free of faults and rich enough from the identifiability point of view, the uncertainty in parameters ($\lambda_i, i=1, \dots, n_\theta$) can be computed by solving an optimization problem (Blesa et al, 2010).

Fault detection using interval models

Once model (1) has been calibrated in a non-faulty scenario, it can be used for fault detection checking if

$$y(k) \notin Y(k) \quad (4)$$

where $\Upsilon(k)$ is the direct image of the uncertain model defined as

$$\begin{aligned} \Upsilon(k) &= \left\{ \hat{y}(k) + e \mid \hat{y}(k) = \boldsymbol{\varphi}(k, \tau)\boldsymbol{\theta}, \boldsymbol{\theta} \in \boldsymbol{\Theta}, |e| \leq \sigma, \tau \in \{\tau^0 - \lambda_\tau, \tau^0 - \lambda_\tau + 1, \dots, \tau^0 + \lambda_\tau\} \right\} = \\ &= \left[\underline{\hat{y}}(k) - \sigma, \overline{\hat{y}}(k) + \sigma \right] \end{aligned} \quad (5)$$

In case that (4) is proved, a fault can be indicated, otherwise no fault can be indicated. Equivalently, the fault detection test (4) can be formulated in terms of the residual defined as

$$r(k) = y(k) - \hat{y}(k) - e(k) = y(k) - \boldsymbol{\varphi}(k, \tau)\boldsymbol{\theta} - e(k) \quad (6)$$

Residual (6) corresponds to a MA parity equation (Gertler, 1998). Ideally, when modeling errors and noise are neglected, residual (6) should be zero in a fault-free scenario and different from zero, otherwise. However, because of modeling errors and noise, residuals can be different from zero in a non-faulty scenario. In order to take into account uncertainty in parameters and additive noise, the effects of these uncertainties will be propagated to the residuals defining the region of admissible residuals. A fault will be detected when zero does not belong to this set. Thus, the fault detection test is equivalent to check the following condition

$$0 \notin \Gamma(k) \quad (7)$$

where $\Gamma(k)$ is the interval of possible residuals defined as follows

$$\Gamma(k) = \left\{ r(k) \mid r(k) = y(k) - \boldsymbol{\varphi}(k, \tau)\boldsymbol{\theta} - e, \boldsymbol{\theta} \in \boldsymbol{\Theta}, |e| \leq \sigma, \tau \in \{\tau^0 - \lambda_\tau, \tau^0 - \lambda_\tau + 1, \dots, \tau^0 + \lambda_\tau\} \right\} \quad (8)$$

This test based on the direct evaluation of the residual is known as the direct test (Blesa et al., 2011).

FTC using Sensor fault masking

Sensor fault masking proposed by (Wu et al. 2006) is a fault-tolerant control strategy that does not require any modification of the control law. Considering the feedback control scheme described in figure 1.(b), when a sensor fault occurs, the faulty measurements directly corrupt the closed-loop behavior (Ponsart et al. 2010).

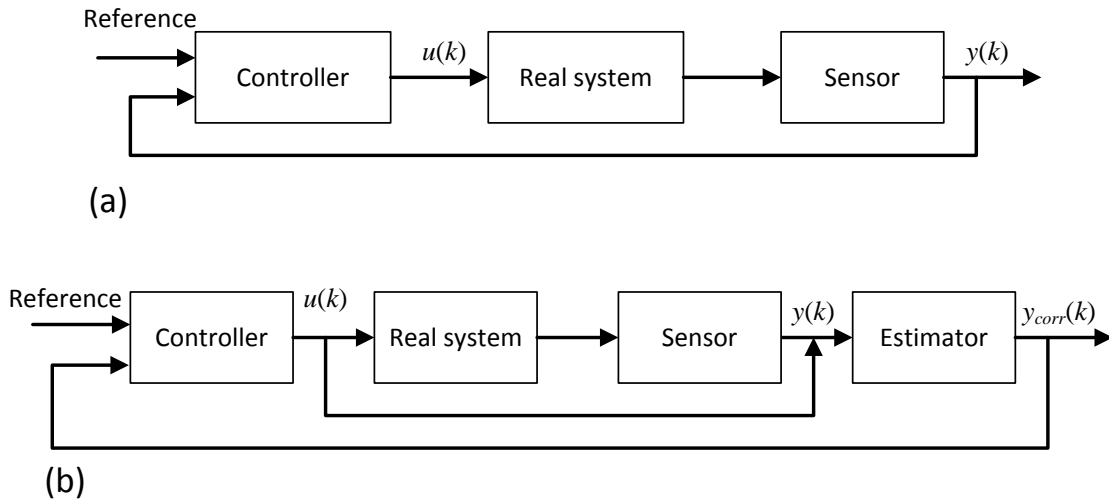

Figure 1. (a) Conventional feedback configuration (b) Fault-tolerant configuration

Moreover, the controller aims at cancelling the error between the measurement and its reference input. In faulty case, the real output is different from the desired value and may drive the system to its physical limitations or even to instability.

Introducing the adaptive estimator of the fault magnitude f_y , see figure 2. (b), a fault-free estimation of the sensor magnitude can be computed as

$$y_{corr}(k) = y(k) - f_y \quad (9)$$

This estimation, decoupled from the fault effects, is used to compute the fault tolerant control law minimizing the effects on the system performance and safety.

In case of using model-based techniques for FDI, the estimation provided by models can be used to estimate the fault magnitude. In particular, residual (6) can be approximated by

$$r(k) \approx s_{f_y}(k) f_y \quad (10)$$

as suggested in (Blesa et al, 2012), where $s_{f_y}(k)$ is the fault sensitivity, that in the case of output sensor fault at the fault appearance instant $k = k_f$, $s_{f_y}(k_f) = 1$. Then, considering the nominal residual

$$r^0(k) = y(k) - \phi(k, \tau^0) \theta^0. \quad (11)$$

The fault estimation can be computed as

$$f_y(k_f) \approx r^0(k_f) \quad (12)$$

The estimated magnitude of the fault has the uncertainty equal to the uncertainty of the interval model (2). After the magnitude of the fault is calculated, the measured variable is replaced by the corrected one using (9). This will be used in the following step of the estimation algorithm for fault detection and also for the controller.

The model for fault detection

The fault detection module is using the Integrator Delay Zero model developed by Litrico & Fromion 2004b. The model is an extension of the Integrator Delay model (Schuurmans 1995). The integrator delay model contains an integrator at low frequencies that accounts for the reservoir behavior of the channel: the water level is the sum of the discharge filling the tank. The delay accounts for the time it takes for the water volume to arrive to the measurement point. According to Litrico & Fromion (2004a) adding a zero to the model improves the high frequency behavior: with the help of the added zero the fast increase in the water level due to the change of discharge can be modeled. This property is crucial in the fault detection scheme.

The parameters of the IDZ model can be obtained from the geometrical properties and the flow of the canal using the equations in (Litrico & Fromion 2004a). The discretized IDZ model can be described with the following equation:

$$y(k+1) = y(k) + a_{11}u_1(k - \tau_1) + a_{12}u_1(k - 1 - \tau_1) + a_{21}u_2(k - \tau_2) + a_{22}u_2(k - 1 - \tau_2) + \dots + a_{n1}u_n(k - \tau_n) + a_{n2}u_n(k - 1 - \tau_n) \quad (13)$$

Each water level is calculated using the same level in the previous step and the input discharges with the corresponding delays. Hence if there is a fault in one level sensor it will just effect the calculation of that level. In this way the isolation of the fault is immediate.

Control scheme

The canal is modeled by the Integrator Resonance (IR) model developed by van Overloop (2010) and has been already applied for irrigation canals (Horváth 2013, van Overloop et. al. 2014). The detailed modeling of the CFR with the Integrator Resonance model is presented in HIC, here only a brief summary is given. The IR model is specially developed for open channels affected by resonance. It acts as an integrator at low frequencies and at high frequencies it has a second order behavior modeling an underdamped wave. The transfer function between the input discharge and the water level can be written as

$$g(s) = \frac{p_1s^2 + p_2s + p_3}{A_s s^3 + \frac{s^2}{Mr} + A_s \omega_0^2 s} \quad (14)$$

Due to its behavior in the frequency domain this model is especially suitable for controller design.

Model predictive control is designed based on van Overloop (2006). The controller design is similar introduced in (Horváth 2013) and applied to this system in (Horváth et. al. 2014b). Each water level is modeled using the IR model. The parameters are obtained as described in the above literature: the backwater surface is approximated as the surface of the canal reach and the resonance frequency and the resonance peak is obtained from the Bode plot of the canal reach obtained according to (Litrico 2008). Each transfer function is obtained in the form of (13) and they are discretized using zero order hold. Then a state space model is constructed using the discretized transfer functions, where the state contains the water level errors and discharges, and the control action variable is the change in discharge.

APPLICATION

The FTC is applied to an open water channel used for navigation. The Cuinchy-Fontinettes Reach (CFR) is part of the navigation system of the north of France. It is 42km long, 50m wide and about 4m deep. In order to ensure the navigation, the water level should be maintained ± 15 cm around the normal navigation level (NNL). The level is disturbed by the operation of the locks located at the downstream (lock of Fontinettes) and the upstream (lock of Cuinchy) end of the system. The downstream lock overcomes 7 m (check) of water level difference, and it removes about 25000m³ of water. The

upstream lock is smaller and it feeds the reach with 3700m^3 . In order to keep the NNL there is a gate beside the lock in the upstream end: the gate of Cuinchy. Also in the middle of the reach there is the gate of Air, that permits flow in both directions (Figure 1). The system has 4 input flows and 3 output levels to control. Detailed description of the case can be found in (Horváth et. al. 2014a).

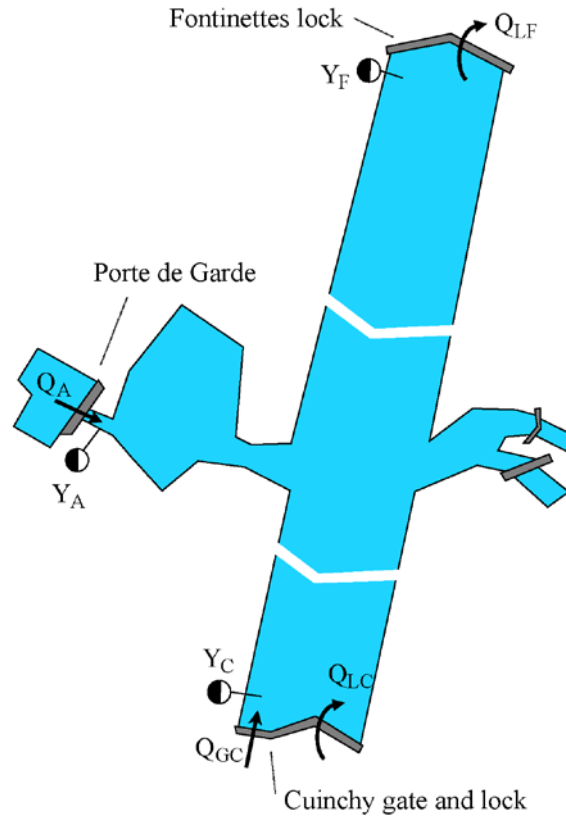

Figure 2: CFR system scheme

Table 1: The geometrical parameters of the CFR

Length, L (km)	L_{CA} (km)	L_{AF} (km)	Width (m)	Depth (m)	Manning's co. (-)	Discharge (m^3/s)
42.3	28.7	13.6	52	3.8	0.35	0.6

The CFR is modeled using the Simulation of Irrigation Canals hydraulic software (Malaterre & Baume, 1997). SIC is using a finite difference solution of the Sain-Venant equations to model the open channel flow. The controller was programmed in Matlab (Mathworks, 2008) environment.

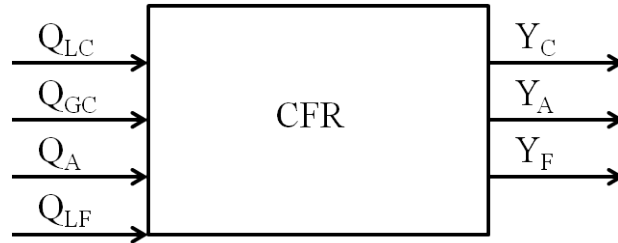

Figure 3: CFR simulation block

Table 2: The resonance characteristics of the CFR

Res. freq (rad/s)	Res. peak (s/m ²)	Backwater surface (m ²)
$4.53 \cdot 10^{-4}$	0.0057	2199600

RESULTS

The FTC is applied to the CFR. Three different magnitudes of faults (-5cm, -10cm and -20cm) are tested on the three different water level sensors, altogether nine scenarios. First, the results of the fault detection module are shown, then resulting controlled water levels are discussed.

Figure 4 show the results of the fault detection. The introduced fault is after 6 hours as -5cm, -10cm and -20 cm (increasing vertically) and shown by gray line. The same magnitude of faults are tested with the three measurement points. It can be seen that if a fault is present at Cunchy (first column), it is detected in case of all magnitudes, with an error less than 1 cm. It can be seen that the fault is detected with no delay and there are no false alarms. Similar results can be seen for Aire (second column) and for Fontinettes (third column). The fault isolation can also be seen: only the corresponding fault signal is activated, the fault indicators of the other levels remain unchanged.

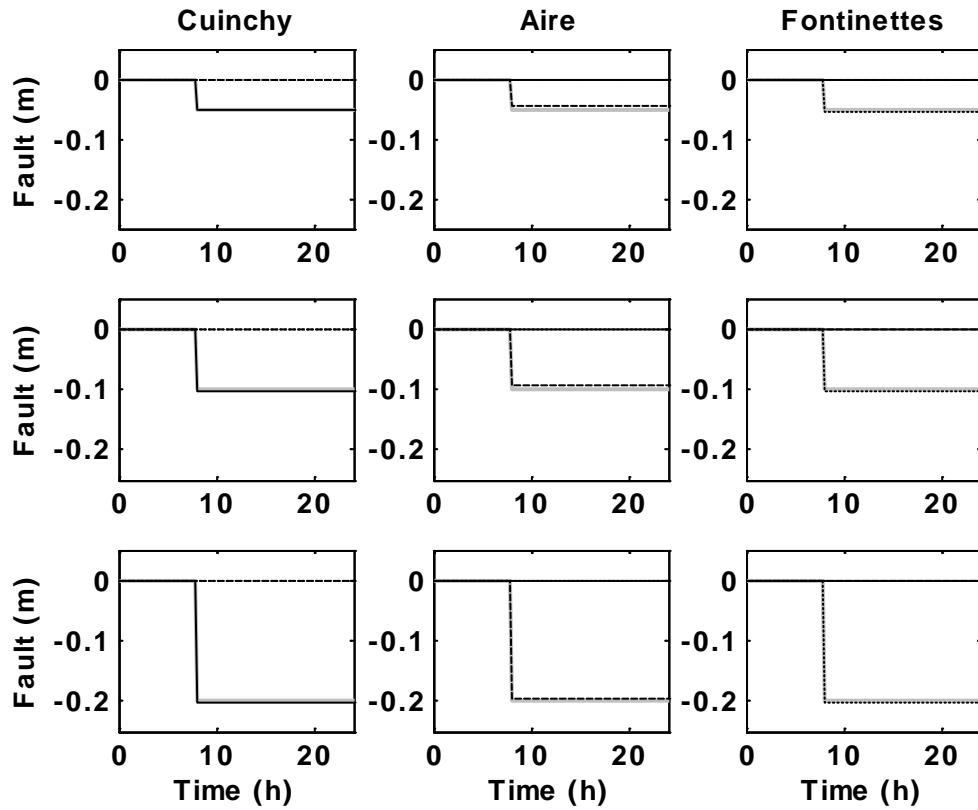

Figure 4: Different faults and detections, with gray line the magnitude of the fault, with black straight line the fault detection at Cuinchy, with black dashed line the fault detection at Aire and with gray dotted line the fault detection at Fontinettes

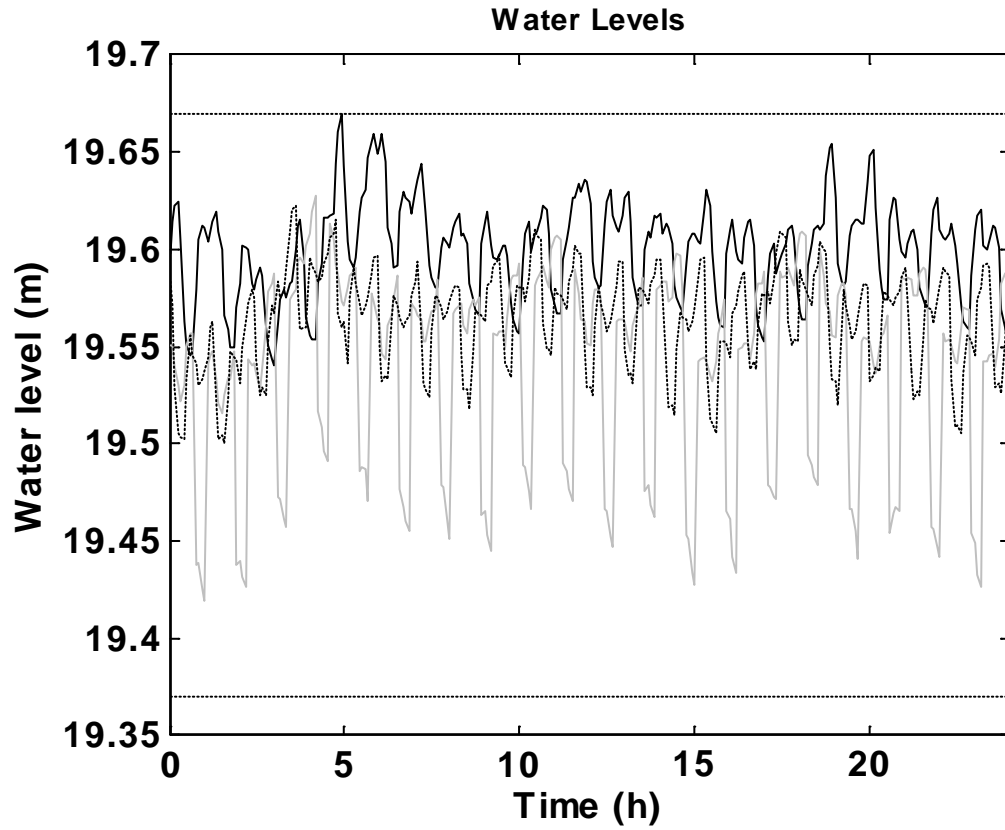

Figure 5: Water levels using MPC, a scenario without fault, Cui chy: black, Aire: black dashed, Fontinettes: gray, the limit of navigation: dashed horizontal line

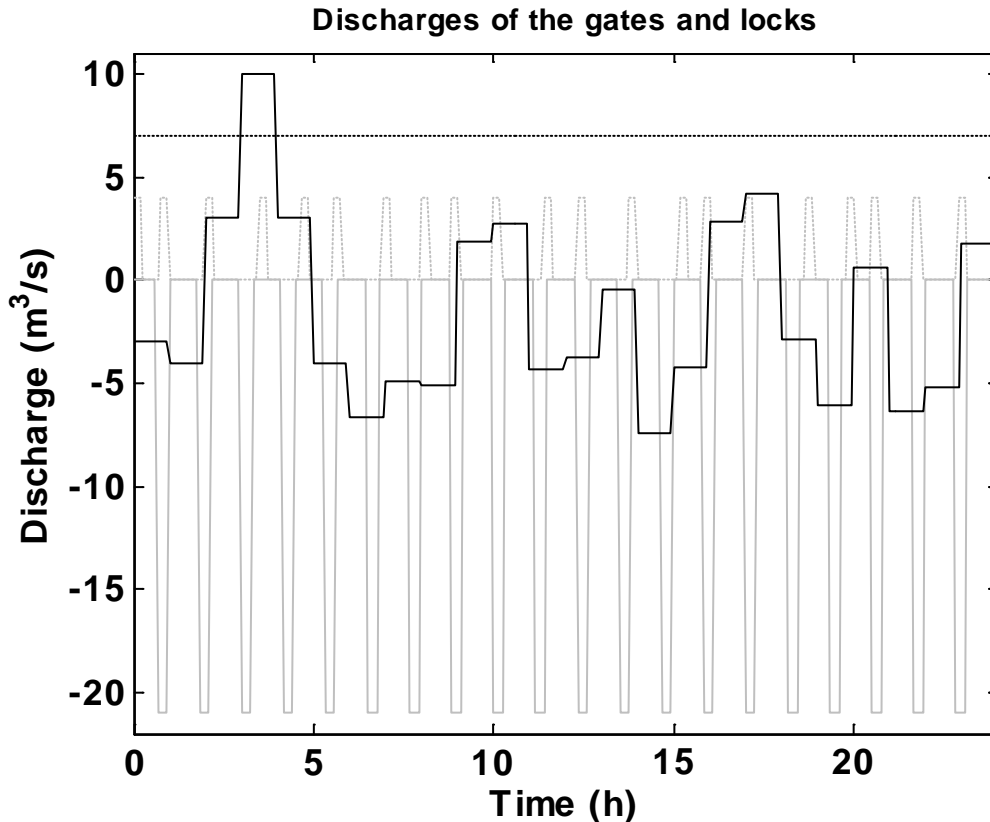

Figure 6: Discharges using MPC a scenario without fault, Cuinchy lock: gray dashed line, Cuinchy gate: black dashed line, Aire: black line, Fontinettes lock: gray

In the following the controlled water levels and the control actions are shown in case of fault-free scenario.

Figure 5 shows the controlled water levels with MPC. It can be seen that while the water levels keep on fluctuating due to the lock operations, all the three water levels are kept within the range of navigation.

Figure 6 shows the control actions and the lock operations. It can be seen that the lock operations correspond to an abrupt change in discharge, especially in case of lock Fontinettes. The controller keeps the upstream input (gate of Cuinchy) constant, at the maximum in order to compensate the water volume taken out by the lock of Fontinettes. The input at Aire fluctuates. The gate movements might seem extensive, however, as the sampling time is one hour, the gate rests in the same position during one hour.

Tables 3 and 4 show the performance indicators with faulty and faultless scenarios with and without using FTC. The first row contains the performance indicators as percentages in case of no fault – the scenario discussed above. The indicators are selected from the indicators suggested by Clemmens et. al. (1998) in order to measure the performance of control algorithms. For each indicator a maximum and an average value is given: these are obtained from the three different levels to be controlled.

Table 3 summarizes the performance indicators without FTC for the 9 different fault scenarios, 3 different fault magnitudes for 3 different sensors. The performance indicators

are detailed in Clemmens et. al. (1998), MAE: mean absolute error, IAE: integral of the absolute magnitude of error. The first line shows the reference values. It can be seen that as the magnitude of the fault increases (for example at Cuiuchy: lines 2-4) the performance indicators are getting worse. For both indicators, the maximum and also the average values decreases in presence of faults. Similar tendencies are seen in each level.

Table 3: Performance indicators of the controller without FTC

Location	Fault Magnitude (cm)	Fault			
		MAE Max (%)	MAE Avg. (%)	IAE Max (%)	IAE Avg. (%)
No Fault	0	4.2	3.5	2.0	1.5
Cuiuchy	-5	4.2	3.8	2.4	1.8
	-10	4.7	4.1	2.7	2.0
	-20	5.7	4.9	3.3	2.6
Aire	-5	4.2	3.8	2.3	1.7
	-10	4.6	4.0	2.6	2.0
	-20	5.5	4.6	3.1	2.4
Fontinettes	-5	4.2	3.8	2.3	1.7
	-10	4.7	4.1	2.6	2.0
	-20	5.6	4.8	3.2	2.5

The same scenarios are summarized in Table 4 using FTC. It can be seen that almost no deterioration is present in the performance indices. Only in case of Aire, the average of MAE and the maximum of IAE decreases by 0.1 %, in all the other cases the performance indicators remain the same. This is a considerable improvement compared to the faultless scenario.

Table 4 Performance indicators of the controller with FTC

Location	Fault Magnitude (cm)	Fault			
		MAE Max (%)	MAE Avg. (%)	IAE Max (%)	IAE Avg. (%)
No Fault	0	4.2	3.5	2.0	1.5
Cuiuchy	-5	4.2	3.5	2.0	1.5
	-10	4.2	3.5	2.0	1.5
	-20	4.2	3.5	2.0	1.5
Aire	-5	4.2	3.6	2.1	1.5
	-10	4.2	3.6	2.1	1.5
	-20	4.2	3.6	2.1	1.5
Fontinettes	-5	4.2	3.5	2.0	1.5
	-10	4.2	3.5	2.0	1.5
	-20	4.2	3.5	2.0	1.5

Now we focus on one of the fault scenarios discussed above, when there is a fault of -20cm at the sensor of Fontinettes. Figure 7 shows the measured water levels for this scenario. After 6 hours, the sensor has a fault of -20 cm. As the controller receives wrong data, it increases the water level and the real water level finally exceeds the navigation range.

The same scenario is shown in Figure 8 but with using FTC. It is seen that all the water levels are within the navigation range. The water levels are similar compared to the faultless results (Figure 5). The FDI module managed to detect and approximate the fault in this way the controller is not affected.

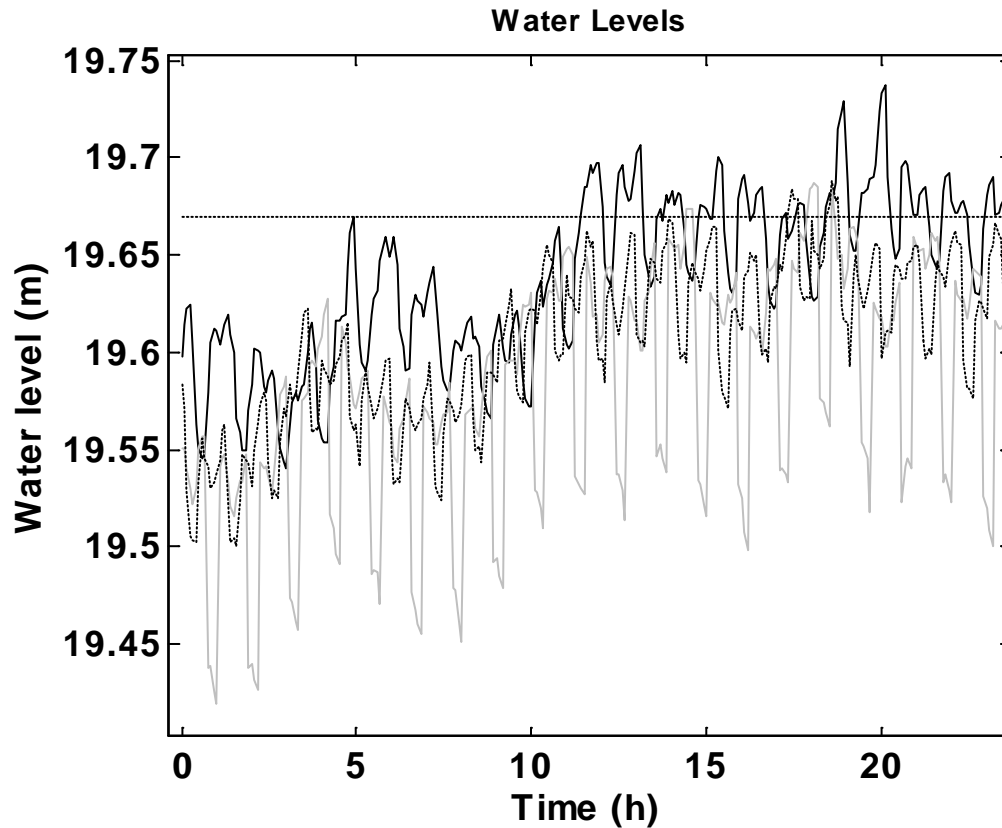

Figure 7: Water levels using MPC without FDI, Cuinchy: black, Aire: black dashed, Fontinettes: gray, the limit of navigation: dashed horizontal line

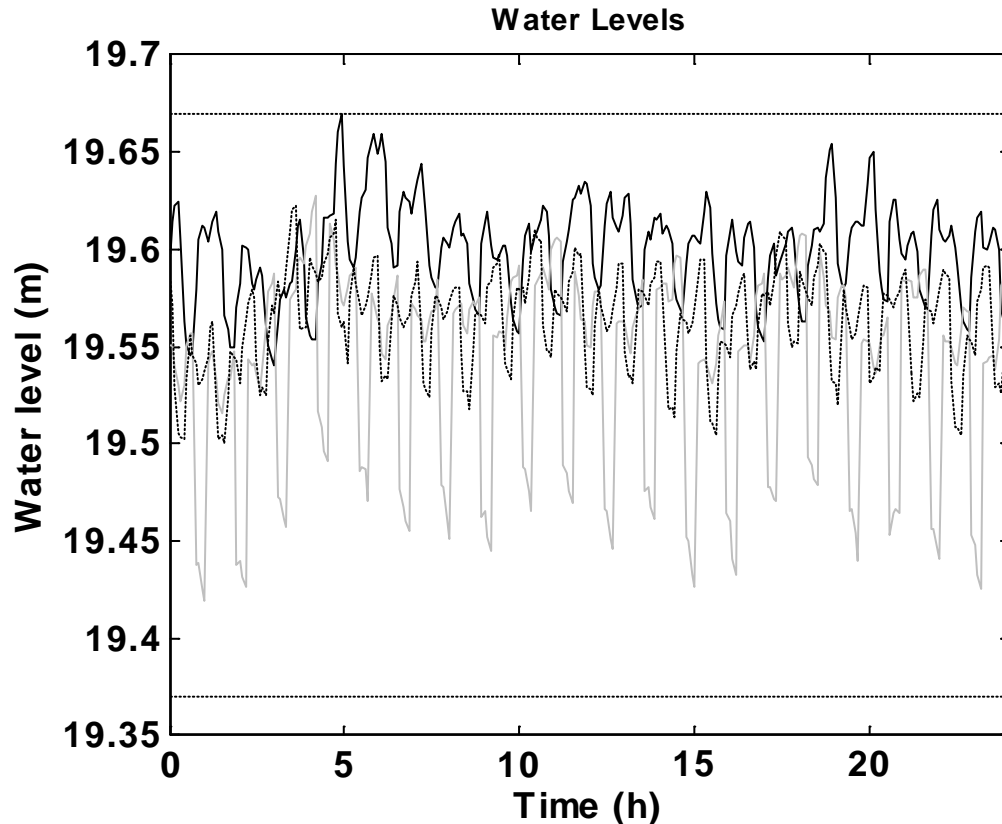

Figure 8: Water levels using MPC with FDI, Cuinchy: black, Aire: black dashed, Fontinettes: gray, the limit of navigation: dashed horizontal line

CONCLUSION

Fault tolerant model predictive control scheme was developed and applied to a case study of open water channel. The fault detection scheme is able to detect single water level sensor errors and correct them in order to maintain the desirable control action. In the test scenario, in presence of sensor faults, the water levels cannot be kept within the interval that ensures navigability. By applying fault tolerant MPC, the water levels are kept within the range of navigation.

REFERENCES

- Akhenak A., Duviella, E. , Bako L. & Lecoeuche S. (2013) Online fault diagnosis using recursive subspace identification: Application to a dam-gallery open channel system, *Control Engineering Practice*, 21(6), pp. 797-806,
- Nadia Bedjaoui N. & Weyer E. (2011) Algorithms for leak detection, estimation, isolation and localization in open water channels, *Control Engineering Practice*, 19(6) pp. 564-573, 2011

Blesa, J.; Puig, V. & Saludes, J (2012). Robust Identification and Fault Diagnosis based on Uncertain LPV MIMO Parity Equations and Zonotopes. "Journal of Process Control ", 22(10) pp. 1890-1912

Blesa J, Puig V. & Bolea Y. Fault detection using interval LPV models in an open-flow canal. Control Engineering Practice 2010; 18(5), pp. 460-470.

Blesa J., Puig, V. & Saludes J. Identification for passive robust fault detection using zonotope-based set-membership approaches. International Journal of Adaptive Control and Signal Processing 2011; 25 (9): pp788–812.

Clemmens, A. J., Kacerek, T., Grawitz, B. & Schuurmans, W. 1998 Test cases for canal control algorithms. J. Irrig. Drain. Eng. 124 (1), 23-30.

Gertler, J. Fault Detection and Diagnosis in Engineering Systems. Marcel Dekker: New York. 1998.

Horváth, K. 2013 Model predictive control of resonance sensitive irrigation canals. PhD Thesis, Technical University of Catalonia, Spain.

Horváth, K., Duviella, E., Blesa, J., Rajaoarisoa, L., Bolea, Y, Puig, V & Chuquet K. (2014a) Gray-box model of inland navigation channel: Application to the Cuinchy-Fontinettes reach. Journal of Intelligent Systems 2014(9)

Horváth, K., Duviella, E., Petreczky, M. & Chuquet K. (2014b) Model predictive control of water levels in a navigation canal affected by resonance waves, 11th International Conference on Hydroinformatics, HIC, New York City, USA

Ljung L. System identification–theory for the user (2nd ed.). Englewood Cliffs, NJ: Prentice-Hall; 1999.

Litrico X. & Fromion V. (2004a) Simplified modeling of irrigation canals for controller design. Journal of Irrigation and Drainage Engineering, 130(5), pp.373–383.

Litrico, X. & Fromion, V. 2004b Frequency modeling of open-channel flow. J. of Hydr. Eng. **130** (8), pp. 806-815.

Malaterre, P.-O. & Baume, J.P. 1997. SIC 3.0, a simulation model for canal automation design. In International Workshop on Regulation of Irrigation Canals: State of art of research and applications, Marrakech, Morocco, ed. A. Mokhlisse, 68-75.

Malaterre P.-O., Rogers D.C., & Schuurmans J., 1995. Classification of Canal Control Algorithms. First International Conference on Water Resources Engineering, Irrigation and Drainage, San Antonio, Texas, USA, 14-18 August 1995. p 6-10.

Mathworks 2008 Matlab. <http://www.mathworks.com/products/matlab/>.

Milanese M., Norton J., Piet-Lahanier H., & Walter E, editors. (1996) *Bounding Approaches to System Identification*. Springer, 1996.

Nabais J.L., Mendonca L.F. & Botto M. A. (2012) Sensor fault tolerant architecture for irrigation canals, 10th Portuguese Conference on Automatic Control 16-18 July 2012, CONTROLO'2012, Funchal, Portugal

Le Pocher, O., Duviella, E., Bako, L.& Chuquet, K. (2012) Sensor Fault Detection of a Real Undershot/overshot Gate Based on Physical and Nonlinear Black-Box Models Fault Detection, Supervision and Safety of Technical Processes, Volume 8, Part 1 Editor: Astorga Z., Carlos M., Molina, A.

Ponsart, J.-C., Theilliol D. & Aubrun C. (2010). Virtual sensors design for active fault tolerant control system applied to a winding machine. *Control Engineering Practice*, 18 (2010) 1037–1044.

Schuermans, J. 1995 Open-channel flow model approximation for controller design. *Applied Mathematical Modelling*, **19** (9), 525-530.

van Overloop, P.-J. 2006 Model predictive control on open water systems. PhD Thesis, Delft University of Technology, The Netherlands.

van Overloop, P.-J. Clemmens A. J., Strand, R. J., Wagemaker R. M. J. & Bautista E. 2010 Real-time implementation of model predictive control on Maricopa-Stanfield Irrigation and Drainage District's WM Canal. *J. Irrig. Drain. Eng.* **136** 747-756.

van Overloop, P.-J., Horváth, K. & B. E. Aydin 2014 Model predictive control based on an integrator resonance model applied to an open water channel Identification of resonance waves in open water channels. *Control Engineering Practice*, **27**, 54-60.

Wu, E. N., Thavamani, S., Zhang, Y., & Blanke, M. (2006). Sensor fault masking of a ship propulsion. *Control Engineering Practice*, 14(11), 1337–1345.

Zhang, Y. & Jiang J. (2008) Bibliographical review on reconfigurable fault-tolerant control systems *Annual Reviews in Control*, 32 (2008), pp. 229–252