

1998

Designing a Function-Enhanced Suction Accumulator for Rotary Compressor

K. N. Yun

United Technologies Carrier Corporation

Follow this and additional works at: <http://docs.lib.purdue.edu/icec>

Yun, K. N., "Designing a Function-Enhanced Suction Accumulator for Rotary Compressor" (1998). *International Compressor Engineering Conference*. Paper 1315.

<http://docs.lib.purdue.edu/icec/1315>

This document has been made available through Purdue e-Pubs, a service of the Purdue University Libraries. Please contact epubs@purdue.edu for additional information.

Complete proceedings may be acquired in print and on CD-ROM directly from the Ray W. Herrick Laboratories at <https://engineering.purdue.edu/Herrick/Events/orderlit.html>

DESIGNING A FUNCTION-ENHANCED SUCTION ACCUMULATOR FOR ROTARY COMPRESSOR

K. W. Yun
United Technologies Carrier Corporation
c/o Daewoo Carrier Corporation
Kwangju, Korea

ABSTRACT

Suction accumulator in rotary compressor is an important component from standpoints of compressor cost, performance, sound and ability of controlling excess liquid refrigerant. Because of its importance, it deserves its due attention to enhancement of its functions. This paper first defines functions of an accumulator, lists major design parameters and their common ranges. Then, a couple of major accumulator designs with an enhanced function are introduced. Advantages of the enhanced accumulators are discussed. Test observations for the accumulators are presented to demonstrate the contribution. Lastly, tests designed to evaluate effectiveness of an accumulator are proposed.

FUNCTIONS OF A SUCTION ACCUMULATOR

Rotary compressor with a conventional suction accumulator attached is shown Fig. 1. The primary function of a suction accumulator in rotary compressor is to control excess liquid refrigerant. Suction accumulator also serves as a multi-function component in a rotary compressor, including suction muffling, filtering of contaminants. A brief discussion for various functions follows:

FILTER - All accumulators are equipped with filtering screen and this is critical for rotary compressor as suction flow directly enters the compression chamber where tight assembly clearances can cause problems. The screen mesh size determines the maximum size of particles that can pass through the filter. If the mesh is too fine, pressure drop across the filter and plugging of the screen may become an issue.

MUFFLER - Accumulator acts as a suction acoustic muffler. Degree of contribution can range widely in overall sound level and in specific frequency bands.

RESERVOIR FOR LIQUID REFRIGERANT - This is the primary function of an accumulator. It separates and collects liquid-phase refrigerant from suction stream. If the liquid is allowed to rush into suction, metallic chattering noise and lubrication difficulties may result.

PERFORMANCE - An accumulator affects compressor performance as a result of suction gas pulsation, pressure drop inside accumulator and heat transfer between accumulator, and surrounding ambient and compressor shell. An accumulator can cost capacity and/or compressor efficiency.

LIQUID REFRIGERANT EVAPORATOR - Some suggests this evaporator function. When liquid-phase refrigerant enters accumulator evaporation of liquid can result as a result of heat transfer to the accumulator. However, study in this regards is scarce.

NOISE RADIATOR - While being a noise muffler in one hand, accumulator also acts as a noise radiator as well as a generator.

DESIGN CONSIDERATIONS

Designing an accumulator is a process of compromising often-conflicting goals among physical constraints, sound, performance, part cost, ability to facilitate oil return and, most importantly, the capacity to control excess liquid refrigerant. There are three key aspects, among others, in designing an accumulator. A brief discussion on these considerations follows:

ACCUMULATOR SIZE - This is the most important consideration. Accumulator sizing depends primarily on the charge amount in a system. In the air conditioning industry, recommended ratio of oil-to-refrigerant differs by company-to company recommendation, but, generally, the value falls in 0.4-0.5 and 0.6-0.7 ranges for cooling-only and heat pump application respectively. Any excess refrigerant that makes this ratio smaller than the recommended numbers should be taken care of by the accumulator volume. From the ratio and anticipated maximum system refrigerant charge, the minimum required accumulator volume is determined. In this case "effective" volume [Fig. 1] is what counts rather than "total" volume. From a survey of rotary compressors of different brands, the ratio, effective/total volume, is found falling in 0.5-0.9 range.

OIL RETURN ORIFICE - Since refrigerant flow always contains refrigerating oil, oil is also collected in accumulator as refrigerant/oil mixture enters the accumulator chamber. To insure oil return to compressor, a provision must be provided to return the collected oil from the accumulator. The oil return is accomplished by an orifice located on the bottom portion of standpipe or "hockey stick" as some call it. In the same survey above, orifice size ranges from 0.8 to 2.0 mm in diameter.

There are several design issues concerning the orifice. First key issue here is how to size the orifice. If the size is too small, it may not be able to return the separated oil inside accumulator fast enough, and oil may back up. On the other hand, if the size is too large, then liquid refrigerant will bypass excessively into compression chamber. Second issue is where to locate the orifice in elevation. An orifice located at the very bottom will tend to pick up contaminant residues easily, while one located high will have more chance to bypass liquid refrigerant. Third issue is locating the orifice in radial direction. The orifice located, in radial direction, near larger radius of standpipe bend is more effective due to higher flow velocity at that location.

NOISE GENERATOR - Relative alignment of standpipe tip to baffle plate opening is critical in generating "whistling" noise. Care must be taken to keep a sufficient distance between flow holes on baffle plate and standpipe opening. Alignment of the standpipe with respect to accumulator body ID is often a critical issue in this respect.

AN ENHANCEMENT

A major enhancement of an accumulator is introduced in this paper. In one version, the enhancement is all built inside the accumulator body, keeping the exterior body left unchanged. It concerns with raising effective volume in essence and this is made possible by using a "hat"-type baffle configuration [Fig. 2 & Fig. 3]. But the enhancement goes beyond simply raising the effective volume. A direct comparison of the conventional vs. the enhanced version is shown in Fig. 1 vs. Fig. 2. In the following, advantages of the enhanced accumulator are discussed:

OPERATING CHARACTERISTICS AND INHERENT ADVANTAGES

The following describes operating characteristics and lists inherent advantages of the enhancement [Fig. 3]:

PERFORMANCE - The enhanced type suffers no performance loss. In fact, capacity and energy efficiency ratio gains are common.

SOUND - Direct sound comparison to conventional shows no appreciable changes.

INCREASED EFFECTIVE VOLUME - The effective volume of accumulator is increased. The "hat-type" configuration facilitates the increase of standpipe height, thus resulting in more effective use of internal volume of the accumulator. For example, increase in effective volume of 25% over the conventional could be easily attained.

LIQUID BREAK-UP - In the enhanced version, liquid can be separated from suction stream and collected inside accumulator either by inducing swirling, break up or both. In the proposed enhancement, it depends more on the latter; liquid breaks up after impinging on top of the "hat."

LIQUID SEPARATION -- An effective separation of liquid is attained by changing the flow directions 180 degree twice. The flow direction is shown in Fig. 3.

"WATER DAM" BENEFIT - When liquid level rises above the baffle level, the vertical portion of the "hat" acts as a "water dam" and hinders the direct flow of liquid refrigerant into the standpipe intake.

GENERATED NOISE - In the case of conventional accumulator, a "whistling" noise can be generated as a result of relative location of flow holes in baffle plate and standpipe opening. Because of no direct connection from baffle holes to standpipe intake, there is no chance of creating this flow-generated noise in the enhanced version.

FLOW BEHAVIOR INSIDE ACCUMULATOR - Observing from a specially-made accumulator with multiple sight glasses, the flow shows no unusual behavior. As expected, the enhanced accumulator seldom allows liquid to go directly into compression chamber of the compressor until the liquid level reaches near at the standpipe intake opening.

Another example of further enhanced accumulator [Fig. 2] is shown in Fig. 4. The accumulator in this example utilizes the "dead" space below the conventional accumulator. Additional volume gained adds all to effective volume.

EVALUATION OF EFFECTIVENESS OF AN ACCUMULATOR

One way or the other, the effectiveness of an accumulator must be verified in actual testing. After verifying performance and acoustic characteristics of the accumulator, its effectiveness in storing and handling liquid refrigerant must be confirmed. Accumulator built with at least two sight glasses, one at accumulator body and the other at the standpipe inlet level is recommended. Along with the arrangement, a boiler sight glass can be of further help. Thermocouples placed at bottom center of compressor lower shell and pressure readings are essential in estimating the condition of the oil feeding bearings. For "dry" or "wet" suction condition, no significant display of activities is expected. However, under severe liquid flood-back condition, effectiveness of an accumulator in storing and handling liquid refrigerant can be verified.

At a given operating condition (preferably high suction and high discharge pressure) and with overcharged refrigerant amount, superheat of suction, discharge gas and oil sump should be determined. In addition, viscosity of lubricating oil can be estimated. These readings are then compared to the established acceptance criteria. Obviously, these will determine how effective an accumulator really is.

RELIABILITY EVALUATION

The enhanced accumulator, being non-conventional, reliability is one of the prime interests. In an accelerated reliability comparison, the enhanced type was compared with the conventional accumulator in a accelerated liquid flood-back test. Reliability test at high discharge pressure (31 kg/sq.cm) and overcharged refrigerant by 150% over the normal system charge confirms gain in oil sump temperature and improvement in lubrication.

Among various evaluation tests, including continuous run conditions (at high load, high pressure differential, high compression ratio); on/off cycling, blocked fan, liquid flood-back and transient slug tests, special attention was given to tests involving suction flood-back (this includes blocked fan test) and transient slugging of liquid refrigerant. The enhanced accumulator offers, under the same system operating condition, substantial advantages in dealing with excess refrigerant and liquid flood-back. Compressors equipped with the enhanced features last longer in life under severe suction flood-back and transient liquid flood-back conditions.

CONCLUSION

An accumulator is more than just a component in rotary compressor. Despite the fact that many brands of compressor share very much same accumulator design, it can still be further enhanced in more than one way. Advantages of these enhancement can be expected and verified in actual testing. Compressor reliability being prime interest of over-charged and long-line split heat pump system, these enhancement can offer significant contributions.

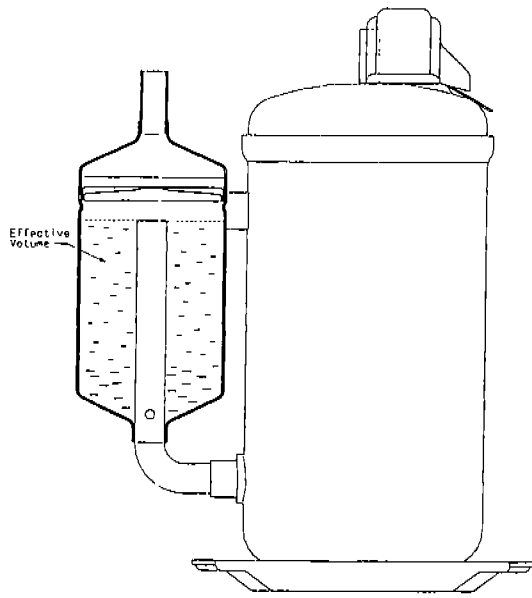

Fig.1 Rotary Compressor With a Conventional Accumulator

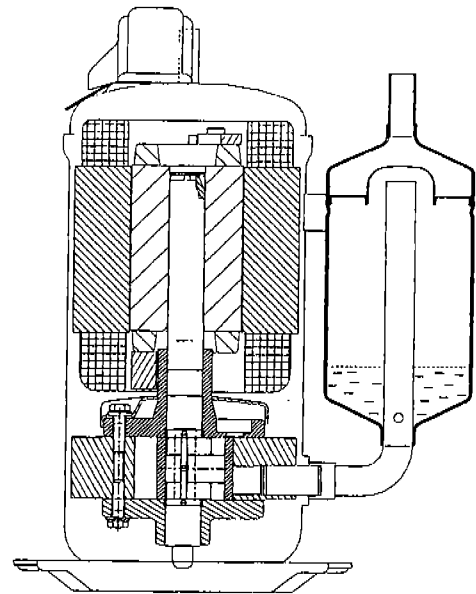

Fig.2 Rotary Compressor With an Enhanced Accumulator

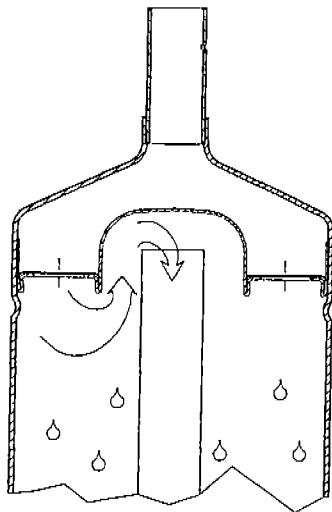

Fig.3 Enhanced Accumulator - Flow Direction

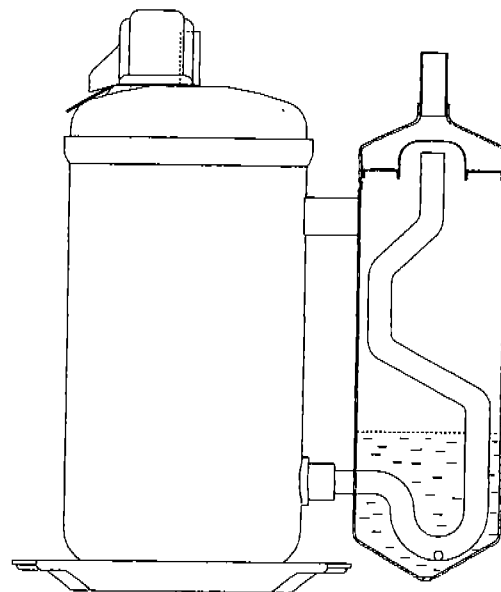

Fig.4 An Alternate Enhanced Accumulator