

Extended Logic Intelligent Processing System For Sensor Fusion

**Adrian Stoica, Tyson Thomas,
Wei-Te Li, and Taher Daud**
Jet Propulsion Laboratory
California Institute of Technology
Pasadena, California

James Fabunmi
AEDAR Corporation,
P.O. Box 1469, Landover, Maryland

Abstract - The paper presents the hardware implementation and initial tests from a low-power, high-speed reconfigurable sensor fusion processor. The Extended Logic Intelligent Processing System (ELIPS) is described, which combines rule-based systems, fuzzy logic, and neural networks to achieve parallel fusion of sensor signals in compact low power VLSI. The development of the ELIPS concept is being done to demonstrate the interceptor functionality, which particularly underlines the high speed and low power requirements. The hardware programmability allows the processor to reconfigure into different machines, taking the most efficient hardware implementation during each phase of information processing. Processing speeds of microseconds have been demonstrated using our test hardware.

Keywords: sensor, fusion, processor, hardware, fuzzy, expert, neural, networks, reconfigurable.

1. Introduction:

1.1. A general need for sensor fusion processors:

With the advent of high-performance sensors and increased processing power more real time applications are now possible. Novel architectures, algorithms, and hardware are required to address the challenges of high sensor bandwidth and the often noisy, sometimes contradictory data present in these new applications. The problem of using more sensors with higher data rates is combined with the need for faster response in real time scenarios, which demands higher levels of computational power. The traditional approach is to build/use increasingly powerful general-purpose processors. Yet, classical algorithms for fusing data (originating in preponderant Bayesian approaches) face challenges in addressing the sensor-fusion problem and more novel approaches, such as the ones coming from the computational intelligence research, can complement or replace the traditional schemes.

Computational intelligence techniques, such as fuzzy logic and neural networks combined with the more traditional Artificial Intelligence paradigm of expert systems proved efficient in solving a category of problems for which an accurate mathematical formulation of models was either not feasible or practically impossible to compute in useful time. The

most pertinent examples of such problems are in pattern recognition and decision-making applications. These techniques are essentially parallel, and thus it is natural to build dedicated processors efficient for these types of operations, which would function in stand-alone mode or as co-processors to provide high-speed computation on massive amounts of data in parallel mode. While these processors can be built both in digital or analog hardware, the massive amount of interconnection lines of a parallel implementation and the power requirements encountered in certain space, military or commercial applications such as hand-held devices make the idea of an analog ASIC processor preferable. An example of such an application requiring low power and fast processing of sensor data is associated with the discrimination performed onboard interceptors.

1.2. Discriminating Interceptor Technology requirements for an on-board sensor fusion processor:

The Ballistic Missile Defense Organization (BMDO) is conducting the Discriminating Interceptor Technology Program (DITP) for the development of advanced and enabling fast frame seeker capabilities. The challenge for the technology is to combat more complex future threats facing the National and Theater Missile Defense (NMD/TMD). The objective is to develop miniaturized interceptor components and subsystems to meet serious space, weight, and power constraints [1]. In this regard, part of a major effort is directed towards the development of new sensor data fusion processing technology that will particularly address high speed and on-board autonomy. This capability can achieve earlier target acquisition, thereby extending the time-to-engage and reducing the dependence on the external battle management and off-board surveillance assets[1].

Once the initially required off-board battle management intelligence is provided to the seeker, the primary goal of the DITP is to exploit the multi-phenomenological sensor data obtained from on-board LADAR and infrared detector arrays for threat engagement via development and integration of real-time sensor fusion algorithms and processors. The overriding hypothesis is that sensor data fusion at three levels (i.e., signal, feature, and decision) is

necessary to improve its capability and to accommodate a wide variety of missions and targets.

In order to meet the challenge of compact, low power, and high-speed on-board data processing, a novel intelligent sensor data fusion processing architecture, termed the Extended Logic Intelligent Processing System (ELIPS), has been developed. ELIPS integrates the analog hardware technology of neural networks, fuzzy logic, and expert rule processing with the conventional digital processing using a host computer. The individual modules are designed to be reconfigurable and cascable. In addition, the overall architecture has been developed to be flexible enough for rerouting of signals to any required processing module by having an interconnecting network with switching arrays.

This paper briefly describes the ELIPS concept and architecture, focusing more on the hardware implementation of the individual ELIPS component modules. Experiments with test chips implementing ELIPS modules illustrate the performance of the analog ASIC implementation.

2. Fuzzy, Expert, And Neural Computation:

Expert systems have been employed in a variety of sensor fusion applications; a recent example is detailed for guiding the user in defining the architecture for the sensor fusion system[2]. Fuzzy logic and neural networks are also becoming widely accepted in the sensor fusion community as techniques with proven capabilities in sensor fusion applications[3-4].

Conditional rule-based systems are using rules of the form "IF a is A AND b is B THEN y is Y" where a, b, and y are the input and output variables respectively, and A, B, Y are classes - in particular fuzzy classes/sets. Thus, a rule-base system can be seen as accepting input data from measurements or preprocessing and providing outputs as transformed by the rules. In particular the outputs could be associated with classes to which the inputs cluster and the magnitude of the outputs associated to the degree of membership to these classes. (Another possible interpretation is that the numbers represent the confidence in the classification, e.g. 70% confidence that the object is target 1, 20% that it is target 2, 10% confidence that it is a decoy.)

New concepts from fuzzy set theory have revitalized the use of rule-base systems, which can cope with the imprecision in matching antecedent clauses. The main operations of fuzzy reasoning are fuzzification, rule evaluations and defuzzification. Fuzzification transforms a crisp input to a degree of membership to a fuzzy set and certain rules are evaluated depending on which fuzzy sets are matched. For certain problems such as classification, this is the

end of fuzzy reasoning - the output results are fuzzy sets and degrees to which they are matched. For example, the output result can be that input signals match the characteristics of target A to 0.8 extent, targets B in degree 0.4 and decoys in degree 0.3; sometimes this can be (improperly) expressed as probabilities, i.e., there is 80% chance/probability/confidence that object is target A, etc. If the desired output is a crisp one, for example an output control signal - the output sets and the associated degrees of memberships are transformed by a defuzzifier into a crisp value. Amongst the most popular methods for defuzzification is the center of gravity method, which requires mainly additions and multiplication.

Neural networks are parallel computation structures characterized by somatic operation between inputs and weights and somatic operations aggregating the weighted inputs and usually passing them through a nonlinear function. Different neural architectures were explored, with different ways of interconnecting the neurons in feed-forward only or in recurrent mode as well, and with a variety of learning rules.

Requirements for fast processing, compact or low power implementation lead to efforts for developing various hardware implementations. The nature of computations involved in fuzzy reasoning is essentially parallel (for example, rule evaluations are independent of each other and can be calculated concurrently). Therefore, a dedicated parallel H/W solution is preferable to a S/W solution on a general-purpose processor and even to a RISC processor with fuzzy-oriented instructions such as VY86C570 (70-microsecond inference speed)[5] or Motorola's 68HC12 (the 1st standard microcontroller family with a comprehensive fuzzy logic instruction set, and the 1st 16-bit engine for fuzzy logic)[6]. Ideally one would want to preserve high versatility of general-purpose processors while reaching low-power high-speed operation. Analog offers the advantage of lower power consumption. While better precision can be obtained in digital implementations, precise computations are not required for fuzzy processing; usually 8 bits are considered sufficient for most applications. (This is because membership functions representing fuzzy classes are usually defined by humans, who can not and do not specify fuzzy set borders with high precision - usually with less than 8 bits). Specific implementations of fuzzy processors are described in the literature[7-11].

The same parallelism is true for neural processing, and ideally H/W implementations should be parallel for maximum efficiency. Similarly for fuzzy expert systems, large number of interconnections and low power justify analog VLSI neural processors. A detailed justification of analog neural processors is presented in Ref. [12].

3. ELIPS Concept And Architecture:

The main assumption behind ELIPS is that fuzzy, rule-based and neural forms of computation can serve as the main primitives of an “intelligent” processor. Thus, in the same way as classic processors are designed to optimize the hardware implementation of a set of fundamental operations, ELIPS is developed as an efficient implementation of computational intelligence primitives, and relies on a set of fuzzy set, fuzzy inference and neural modules, built in programmable analog hardware. The hardware programmability allows the processor to be reconfigured into different machines, taking the most efficient hardware implementation during each phase of information processing.

The ELIPS architecture (Figure 1) is designed to accomplish, for the first time, a fully parallel implementation and seamless integration of three artificial/computational intelligence technologies[13]: (1) membership-function-based fuzzy logic; (2) rule-based expert systems; and (3) massively parallel artificial neural networks. In its initial demonstration, ELIPS will perform functions of discrimination, recognition, tracking, and homing [1]. It is necessary to develop a design that is hardware-implementable using very large scale integration (VLSI) technology. Additionally, it should provide an ultra low power embodiment in a compact package, with an unprecedented signal processing speed (10 to 15 microseconds for each operation), at least three orders of magnitude faster compared to a conventional digital machine (e.g. several milliseconds on a personal computer, PC).

ELIPS is envisaged as a synergistic processor incorporating four processing modules illustrated in Figure 1. PFN and PRN refer to Programmable Feed-forward and Recurrent (feedback) Neural networks, respectively, FSP is a Fuzzy Set Processor, and MERP stands for Multistage Expert Rule Processor. ELIPS modules are destined to work cooperatively in a variety of configuration sequences. For example, to implement fuzzy expert reasoning as a processing sequence of PFN, FSP, and MERP modules, fuzzification is performed by FSP, rule evaluation is done by MERP, while defuzzification (when needed) is done using the PFN.

4. Elips Building Blocks And Their Hardware Implementations:

4.1. The neural (PFN and PRN) modules:

Neural network modules are implemented around a neural chip-architecture developed at JPL[12,14]. The chip, termed NN64, consists of a 64 x 64 array of 8-bit synapses with 8-bit local static memory, 64

neurons, and registers for data and control. The chip is designed to implement a feed-forward or a recurrent neural network with various network topologies with up to 64 neurons.

4.1.1 Functional description of analog processing in NN64: The 64 analog voltage inputs first get converted to currents by a row of V-I converters at the top of the 64 x 64 synaptic array. Each V-I circuit actually produces two currents: I and 16 x I. These signals are then broadcast down each column for each of the 64 inputs so that all the synapses in a column receive the same input.

The building block for the NN64 array is a current-mode multiplying analog to digital converter (MDAC) which forms the basis of the synapse (Figure 2). A byte, which controls switches D1 to D7 to scale current copies of the input, is stored in a local static memory (SRAM) for each synapse. By switching in different multiples of the input current and adding them together, the input current is effectively multiplied by the digital weight stored in the local SRAM. The most significant bit (MSB) of the digital weight (D8+/D8-) controls the sign of the product by steering the synapse output current so that it is either sunk or sourced through the output node. Synapses on the same row have their outputs summed by attaching them all to the same wire. These 64 signals, one for each row of the array, are then sent to 64 separate neurons where they are either processed through the neuron or sent directly out, depending on how the neurons are programmed. If the neuron is on, the current is converted to a voltage through a small resistor and applied to a small differential amplifier that outputs a voltage. Should the neuron be off, the output current is routed directly out off the chip as a current.

4.1.2. Digital programming of NN6: The synapses are loaded single row at a time. The data for a given row is clocked into a 64 long 8-bit wide shift register, one byte at a time. After 64 clock cycles, the data for an entire row of synapses is ready to be loaded into the local memory of each MDAC. A 6-bit row address is supplied and an active-low load signal is asserted, which dumps the data into the synapses on the row specified. Alternatively, a synchronous loading scheme may be used. This method employs a single bit shift register to act as a token ring and specify consecutive rows for loading. When reset is asserted, the top of the token ring corresponding to row 1 is set while the rest of the shift register is reset. As data is clocked in, a 6-bit counter keeps track of how many bytes have been loaded. When the carry-out of the counter indicates that the entire data has been loaded, a load signal is automatically generated that activates

the row on its rising edge and passes the token to the next row on its falling edge. In this way the entire array of synapses can be loaded from the top row down by simply clocking in 4096 bytes of data. Neurons are also programmed with a single bit shift register. If a control signal is asserted, all neurons are automatically bypassed since the entire register is reset. Otherwise, a single bit is clocked 64 times by a special clock. The register loads from the bottom up so that the first data loaded corresponds to the first row neuron. More details on the NN64, including its configuration as a recurrent neural network can be found in the literature[14]. The chip was tested in a variety of applications where neural networks proved efficient. A particular application was interpretation of visual input data for automatic tracking of a path by a mobile robot[13].

4.2. The fuzzy set processor (FSP) module:

The main function of a fuzzy set processor is signal transformation, which can be interpreted as,

- fuzzification - i.e. association between an input crisp signal and a degree of membership to a fuzzy set/class, or
- signal conditioning/ non-linear transformation, coordinate transformation.

The FSP was designed as a processing module with 16 inputs of 5 membership classes each. The chip has 16 analog voltage inputs and 16x5 outputs, and allows digital programmability of the membership functions for each input variable. The membership functions have trapezoidal shape, with programmable parameters for the legs and slopes as illustrated in Figure 3. The position of the legs can be specified with 8-bit resolution and the slope with 5-bit resolution. The equations that describe the output of a trapezoidal membership function are:

If $X \leq A$, $Y = \text{Low}$

If $A < X < (CD+AB)/(B+C)$, $Y = \text{MIN}(BX-AB + \text{Low}, \text{High})$

If $(CD+AB)/(B+C) < X < D$, $Y = \text{MIN}(-CX + CD + \text{Low}, \text{High})$

If $X > D$, $Y = \text{Low}$,

where A is the location of the left leg, B is the unsigned slope of the left leg, C is the unsigned slope of the right leg, and D is the location of the right leg. The chip design currently uses Low = 1 volt and High = 4 volts with Vdd = 5 volts.

The schematic diagram in Figure 3 details the processing path of a single membership function circuit (MFC). While inputs and outputs are in voltage mode for external compatibility, the internal MFC implementation is in current-mode. The input voltage enters the first processing block, which is a Voltage to Current (V/I) converter. Currents proportional to the digital values of the legs, A and D, are generated in

Multiplying Digital to Analog Converters (MDACs). The current corresponding to the left leg gets subtracted from a copy of the input current, while a different copy of the input current gets subtracted from the right leg current. The resulting currents, which correspond to the left and right sides of the trapezoid, enter their appropriate Dividing Digital to Analog Converter (divDAC) where the signals are divided by 5-bit digital values to scale the slopes. The minimum of the two resulting values is then selected which chooses the side that is along the trapezoid. The top of the trapezoid is achieved by taking the minimum of the resulting current and the full-scale current, and this result is converted to the voltage output of the MFC. A test chip for 2 input variables with 5 membership functions calculating the degree of membership has been implemented and tested. A variety of membership functions generated by the chip is illustrated in Figure 4.

Signals obtained from the chip are also illustrated below in a discrimination task. The results are compared with the software implementation and show accurate reproduction in hardware of the results obtained by simulation. Figure 5 shows an example of how the membership functions are used to separate the spaces containing targets and decoys. The software simulated membership function shapes are compared with the programmed hardware output of the membership as shown in the lower graph in Fig. 5. The variables are transformations of some measured parameters characterizing target and decoy signals. The software results show that signals processed using these membership functions would result in discrimination of targets and decoys, as well as targets of different types based on available DITP data. Figure 5 shows discrimination between two targets. Similarly, discrimination distinguishing targets from decoys was also performed successfully by programming the chip. The hardware tests show that the fuzzification/discrimination of this type would take less than a microsecond.

4.3. The multistage expert-rule processor (MERP) module:

The main function of a rule processor is to evaluate matches between input data and classes of knowledge (the satisfaction of certain conditions by the input) and prescribe the implications for such cases. The general structure of processing in MERP is by inference on a collection of rules of the form:

Rule 1. IF a_1 is A_{11} AND a_2 is A_{12} AND ... a_m is A_{1m} THEN y is Y_1

...

Rule n. IF a_1 is A_{n1} AND a_2 is A_{n2} AND ... a_m is A_{nm} THEN y is Y_n

where A_{ij} are fuzzy sets or their complements, i.e. if A_{im} is a predetermined trapezoidal membership function/fuzzy set and A_{ik} is its complement then $A_{ik} = \text{NOT}(A_{im})$. Consider the degree of membership/matching a fuzzy set/class being calculated by the FSP, and thus “a is A” being replaced with u , which is the degree to which “a is A”. The complement is commonly calculated either as the difference to unity, i.e. $\text{NOT}(u) = 1-u$, or as the maximum of all other classes except the one to be complemented, i.e. if classes covering input space are u_1, u_2, u_3, u_4 then the complement is $\text{NOT}(u_3) = \text{MAX}(u_1, u_2, u_4)$. We built test circuitry to calculate the complement in both ways but only the second version was so far integrated within a rule-system chip. The conjunction AND is treated as the MIN operator. Thus, the antecedent “ a_1 is A_{n1} AND a_2 is A_{n2} AND ... a_m is A_{nm} ” can be read after fuzzification as $(u_{n1} \text{ AND } u_{n2} \text{ AND } \dots \text{ AND } u_{nm})$ and calculated as $u_n = \text{MIN}(u_{n1}, u_{n2}, \dots, u_{nm})$. The collection of rules in the rules base can be read as Rule1 OR Rule 2 OR...Rulen; several rules may refer to the same conclusion/class. The logical connective OR is calculated as MAX, thus the degree of supporting an output class is the maximum of all the degrees of supporting that class coming from different rules in the rule-base.

The processing stages calculating complement, conjunction and disjunction are reflected directly in the MERP architecture presented schematically in Figure 6. Stage 1 calculates the complement by MAX operation; Stage 2 calculates the conjunction within the same rule by MIN operator; Stage 3 calculates the disjunction of all rules that refer to the same conclusion by MAX operator. The controls specify which components are selected for MIN and MAX in different rules.

The MERP module is designed as a processing module with 16 inputs with 5 membership classes each; a complement is calculated for each membership class inside the module. The module supports rules with up to 64 conjunctions; up to 128 rules can be programmed in the module and 32 decisions can be obtained as outputs. The implementation of the MERP module is performed in four development phases allowing testing of various circuits (such as analog MIN and MAX circuits) and system/integration solutions before a full-scale more expensive chip is attempted. Figure 7 shows test results from a fabricated MIN circuit (the upper waveforms are the input and the lower one is the output, which is the minimum of the two).

A smaller version of MERP (called miniMERP) with 2 inputs and 4 rules was laid out on a test chip. The chip was fabricated and tested successfully. The propagation time of a signal from inputs to output was around two microseconds. Phase 3 of development

consists in integrating 8 analog inputs, 40 membership functions and 9 rules circuits on the same Fuzzy Expert System (FES) chip. The membership functions are digitally programmable trapezoids. The rules are digitally programmed to select from various membership functions for each input variable, including membership function complements. Each rule performs a conjunction amongst selected membership functions and their complements (one per variable). All analog circuitry is current-mode and the rule output currents are available in parallel on nine separate lines. The chip was fabricated and is currently under test.

4.4. Integration of ELIPS components

Efforts are ongoing for testing the synergistic operation of ELIPS components before the final cut-off design. In this sense a board is prepared to test a Hybrid Neuro Fuzzy Expert System (NFES).

4.4.1 Hybrid Neuro Fuzzy Expert System (NFES):

A new test chip, termed ELIPS3, contains the second generation Membership Function Circuit (MFC) which is a voltage input/output circuit that uses current-mode processing and is digitally programmable with a generic trapezoidal shape membership function. ELIPS3 contains ten MFCs, five of which are associated with each of the two input variables. Another test chip, termed FES1, contains a similar circuit for the membership function processing but the I/V output conversion is eliminated and the current is directly passed to the rule circuits, which are part of the MERP. Current-mode rule circuits process the membership function information on the same chip before creating as output the conclusions of nine different digitally programmed rules. The rules are conjunctive (AND) and complemented or non-complemented membership function values may be used for processing. FES1 contains forty membership function circuits with five associated with each of eight input variables. Each of the nine rules may be configured to process any combination of complemented or non-complemented membership values from any of the eight input variables.

4.4.2 FANN Board:

The Fuzzy-Artificial Neural Networks (FANN) test-board was designed to test the FES1 fuzzy-expert chip as well as to allow configurations of neural and fuzzy systems that combine two NN64 chips and four FES1 chips. The board also includes four analog multifunction converters capable of performing defuzzification processing and enabling a fuzzy system entirely in hardware. A photograph of the test-board is shown in Figure 8. The different system architecture configurations are achieved by setting the appropriate

jumper blocks, while the membership function shapes, rules, and neural network weights can be programmed through the computer interface. LabVIEW Full Development System 5.1 software is used to program the FANN via National Instruments ATMIO64E-3, PCI-DIO-96, and AT-AO-10 interface boards, which provide the required analog and digital I/O. The LabVIEW Fuzzy Toolbox is used to provide a high-level user interface for programming the FES1 chips, allowing the user to specify a high-level fuzzy system that then gets translated and downloaded to the fuzzy hardware on the FANN board.

The board allows 4 FES chips to be mounted on it, such that up to 36 rules can be programmed. In addition, the board incorporates the design for testing of the neural network chips, with 2 NN64 chips and a group of 16 quad - A/D chips. The board aims to play multiple roles, allowing:

- the test of the FES and NN64 chips individually,
- the test of the chips in tandem configuration, e.g. FES followed by NN64, etc.
- the test of the fusion algorithm in hardware, using the neural chips.

5. Conclusions:

Current technology allows the realization of a sensor fusion processor as a multi-chip module (MCM). A trade-off is to be made between the performance and cost of such a processor. Computational intelligence elements such as fuzzy reasoning and neural networks technology are considered fundamental for a sensor fusion chip. Several test chips implementing components of the ELIPS sensor fusion architecture have been fabricated in analog VLSI hardware and demonstrated processing times of the order of microsecond for a variety of tasks, such as target classification from preprocessed data.

6. Acknowledgment:

The research described in this paper was carried out by the Jet Propulsion Laboratory, California Institute of Technology, and was sponsored by the Ballistic Missile Defense Organization through an agreement with the National Aeronautics and Space Administration. Reference herein to any specific commercial product, process, or service by trade name, trademark, manufacturer, or otherwise, does not constitute or imply its endorsement by the United States Government or the Jet Propulsion Laboratory, California Institute of Technology.

7. References:

1. B. Figie, et al., "Discriminating Interceptor Technology Program (DITP): Sensor Fusion for Improved Interceptor Seekers," AIAA/BMDO Missile Sciences Conference, Session 8: Ballistic Missile Defense Interceptor Technology, 1996.
2. B. V. Dasarathy and S. D. Townsend, "GIFTS – A Guide to Intelligent Technology Selection", Proc. International Conf. on Multisource-Multisensor Information Fusion, H. Arabnia and D. Zhu (Eds) Las Vegas NV, July 6-9, 1998, CSREA Press, pp. 65-72.
3. Y. Xia and J. Wang, "Recurrent Neural Networks for Shortest-Path Routing" International Conf. on Multisource-Multisensor Information Fusion, H. Arabnia and D. Zhu (Eds) Las Vegas NV, July 6-9, 1998, CSREA Press, pp. 237-244.
4. D. Zhu and B. Zhang, "Fuzzy Sensor Data Fusion in GPS Vehicle Positioning", International Conf. on Multisource-Multisensor Information Fusion, H. Arabnia and D. Zhu (Eds) Las Vegas NV, July 6-9, 1998, CSREA Press, pp. 259-266.
5. Togai InfraLogic, Inc., "FCA Chip", <http://www.ortech-engr.com/fuzzy/fcachip.html>,
6. C. von Altrock, "Motorola Semiconductor and Inform Software Corp. release fuzzy logic tools for 68HC11 and 68HC12 families" http://www.fuzzytech.com/e_presmo.htm, 1997.
7. S. Guo, and L. Peters, "A High-Speed, Reconfigurable Fuzzy Logic Controller," IEEE Micro, 15: (6) 65-65, 1995.
8. H. Huertas, et al., "Integrated Circuit Implementation of Fuzzy Controllers," IEEE J. Solid-State Circuits, 31: (7) 1051-1058, 1996.
9. J. Fattaruso, et al., "A Fuzzy Logic Inference Processor," IEICE Trans. Electron., E77C: (5) 727-732, 1994.
10. M. Sasaki, et al., "Current-Mode Analog Fuzzy Hardware with Voltage Input Interface and Normalization Locked Loop," IEICE Trans. Fundamentals, E75-A: (6) 650-654 June 1992
11. A. Kandel and G. Langholz, "Fuzzy Hardware: Architecture and Applications", Kluwer Academic Pub., Jan 1998.
12. S. Eberhardt, et al, "Analog VLSI Neural Networks: Implementation Issues and Examples in Optimization and Supervised Learning," IEEE Trans. Indust. Electron. v39 (6):p. 552-564, 1992.
13. T. Daud, et al., "ELIPS: Toward a sensor fusion processor on a chip," Proc. SPIE/AeroSense Conf., vol. 3719, 1999, Orlando, FL, pp 209-219.
14. T. Duong, et al., "Learning in Neural Networks: VLSI Implementation Strategies", In Fuzzy Logic and Neural Networks Handbook, Ed: C.H. Chen, McGraw-Hill, 1996, pp. 27.1-27.48

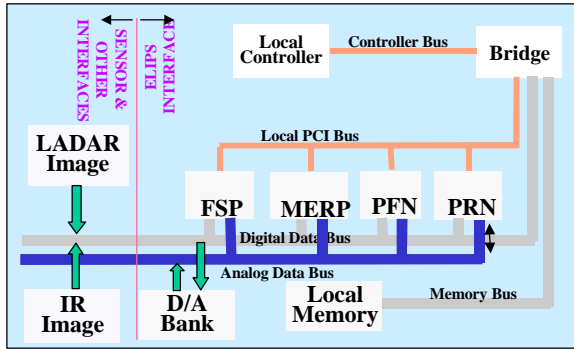

Figure 1. ELIPS architecture with modules

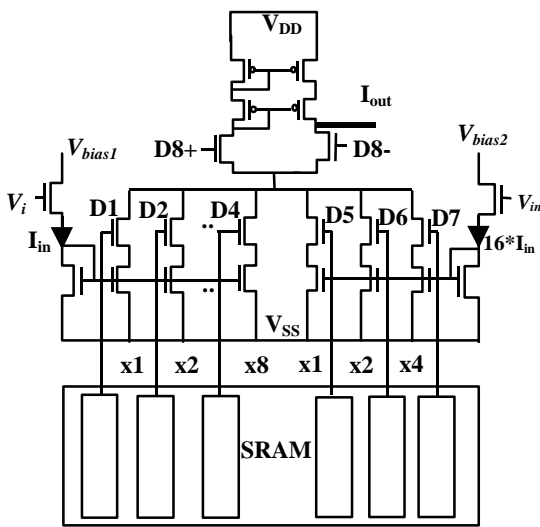

Figure 2. Circuit for the 8-bit synapse

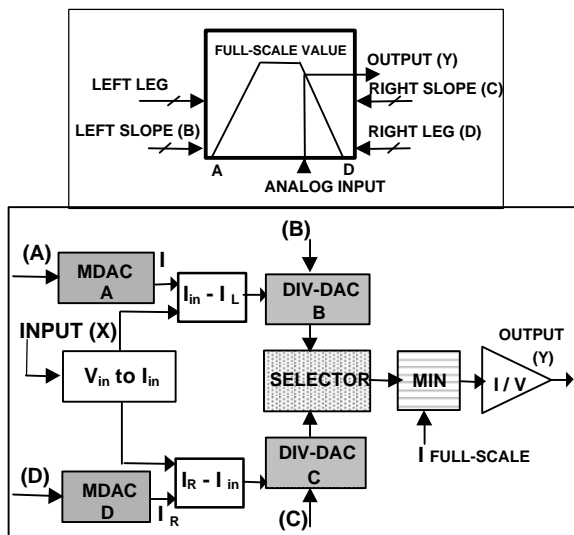

Figure 3. Block diagram of HW implementation for a MFC.

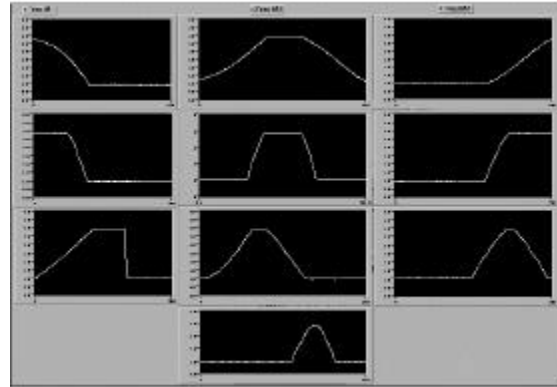

Figure 4. A variety of membership function shapes generated on the MFC test chip

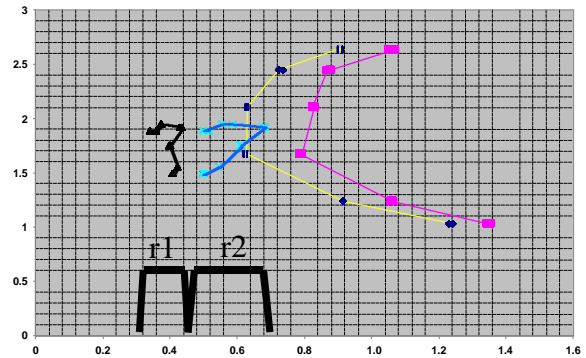

Figure 5 (a). A simulation result showing the required trapezoidal membership functions for discrimination of two targets $r1$ and $r2$.

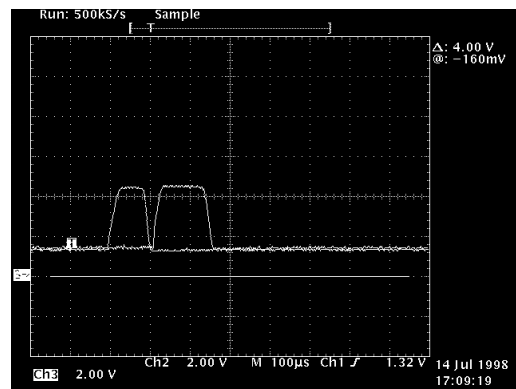

Figure 5 (b). Membership function circuit test result showing identical membership functions.

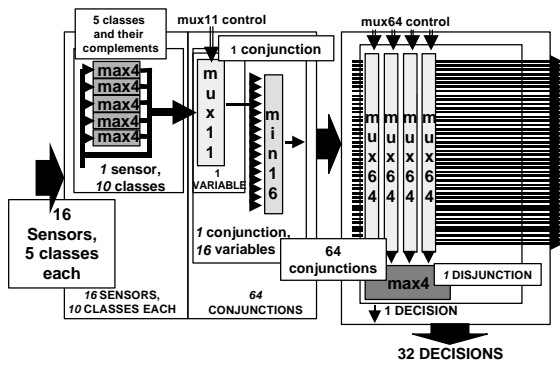

Figure 6. A schematic of the MERP architecture

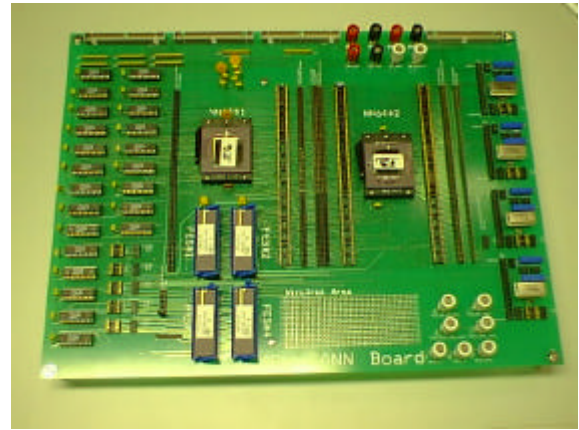

Figure 8. A photograph of the Fuzzy-Artificial Neural Networks (FANN) test-board populated with two NN64 and four FES1 chips.

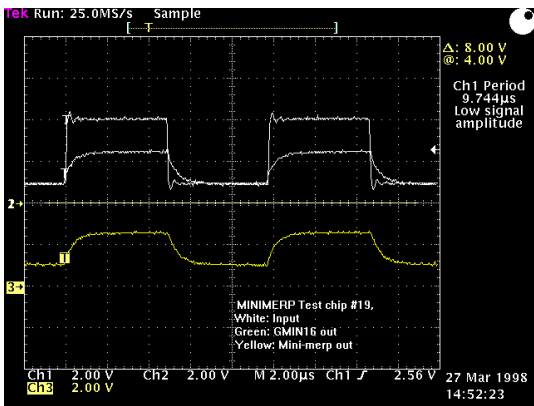

Figure 7. Propagation delay test on a miniMERP circuit. Bottom curve is the output, as the smaller of the two inputs.