

CRYOGENIC AND VACUUM SECTORISATION OF THE LHC ARCS

M. Bona, P. Cruikshank, W.K. Erdt, J.L. Perinet-Marquet, A. Poncet, P. Rohmig, U. Wagner,
T. Wikberg*

Abstract

Following the recommendation of the LHC TC of June 20th, 1995 to introduce a separate cryogenic distribution line (QRL), which opened the possibility to have **a finer cryogenic and vacuum sectorisation of the LHC machine** than the original 8 arcs scheme, a working group was set up to study the implications: **technical feasibility, advantages and drawbacks** as well as **cost** of such a sectorisation (DG/DI/LE/dl, 26 July 1995).

This report presents the conclusions of the Working Group.

In the LHC Conceptual Design Report, ref. CERN/AC/95-05 (LHC), 20 October 1995, the so-called "Yellow Book", a complete cryostat arc (~ 2.9 km) would have to be warmed up in order to replace a defective cryomagnet. Even by coupling the two large refrigerators feeding adjacent arcs at even points to speed up the warm-up and cool down of one arc, **the minimum down-time of the machine needed to replace a cryomagnet would be more than a full month (and even 52 days with only one cryoplant).**

Cryogenic and vacuum **sectorisation** of an arc into smaller sectors is **technically feasible** and would allow to **reduce the down-times considerably** (by one to three weeks with four sectors of 750 m in length, with respectively two or one cryoplants).

In addition, sectorisation of the arcs may permit a more flexible quality control and commissioning of the main machine systems, including cold testing of small magnet strings.

Sectorisation, described in detail in the following paragraphs, consists essentially of installing several additional cryogenic and vacuum valves as well as some insulation vacuum barriers. Additional **cryogenic valves** are needed in the return lines of the circuits feeding each half-cell in order to complete the isolation of the cryoline QRL from the machine, allowing intervention (i.e. venting to atmospheric pressure) on machine sectors without affecting the rest of an arc. Secondly, and for the same purpose, **special vacuum and cryogenic valves** must be installed, at the boundaries of machine sectors, for the circuits not passing through the cryoline QRL. Finally, some additional **vacuum barriers** must be installed around the magnet cold masses to divide the insulation vacuum of the magnet cryostats into independent sub-sectors, permitting to keep under insulating vacuum the cryogenically floating cold masses, while a sector (or part of it) is warmed up and opened to atmosphere.

A reasonable scenario of **sectorisation**, namely **with four 650-750 m long sectors per arc**, and each consisting of 3 or 4 insulation vacuum sub-sectors with two to four half-cells, would represent **an additional total cost of about 6.6 MCHF** for the machine. It is estimated that this capital investment would be paid off by time savings in less than three long unscheduled interventions such as the change of a cryomagnet.

LHC Division, *EST Division

Administrative Secretariat
LHC Division, CERN
CH - 1211 Geneva 23
Switzerland
Geneva, 30 September 1996

TABLE OF CONTENTS

ABSTRACT

1	INTRODUCTION	3-5
1.1	Study inputs	3
1.2	Levels of sectorisation	4
1.3	Short, medium and long interventions (repairs, etc.)	4
1.4	Installation, quality control and commissioning	4-5
2	SECTORISATION OF THE LHC ARCS	5-8
2.1	System layout	5
2.2	Cryogenic sectors	5-6
2.3	Beam vacuum sectors	6
2.4	Insulation vacuum sub-sectors	6-8
3	CRYOGENICS (scenarios, etc.)	8-14
3.1	Warm-up of one sector for a long intervention	8
3.2	Cool down of one sector after a long intervention	9
3.3	Warm-up of one sub-sector for a short intervention	9
3.4	Cool down of one sub-sector after a short intervention	9
3.5	Protection against overpressure	10
3.6	Purging and pressure testing	10
3.7	Cool down and warm-up times	11-13
3.8	Additional cryogenic equipment	13-14
4	VACUUM (scenarios)	14-15
4.1	Pumping	14-15
4.2	Venting of vacuum sectors	15
4.3	Leak testing	15
5	COST ANALYSIS	15-16
5.1	Cryogenic system	15
5.2	Vacuum systems	16
5.3	Grand total	16
5.4	Savings (cost of lost physics time)	16
6	DISADVANTAGES OF SECTORISATION	17
7	CONCLUSION AND FURTHER WORK	17

ANNEXES

CRYOGENIC AND VACUUM SECTORISATION OF THE LHC ARCS

M. Bona, P. Cruikshank, W.K. Erdt, J.L. Perinet-Marquet, A. Poncet,
P. Rohmig, U. Wagner, T. Wikberg

1 INTRODUCTION

The aim of sectorisation is to reduce LHC down-time when repairing any defective component in an arc. By minimising the number of magnets which must be warmed to room temperature, the total warm-up and cool down-times for the intervention can be reduced.

Sectorisation may also allow:

- a) more flexible and convenient installation, checks and controls (e.g. leak checking, cold testing of components, ...);
- b) possibly separate commissioning of sub-systems and components;
- c) routine maintenance of subsystems or components during scheduled shutdowns;
- d) reduction of the number of full temperature cycles for the machine components.

1.1 Study inputs

The boundary conditions of the sectorisation study are those of the LHC design report ("Yellow Book"), i.e. with a separate cryogenic distribution line (QRL), 4 feed points and parallel feeding of the cryogenic fluids from the QRL to the half-cells, except the cryostat thermal screen cooling at 50 - 75 K (line E*), which is installed in series along an arc via the magnet cryostat and with the return in the QRL. A notable exception (to the "Yellow Book" reference) has been the pumping line B* of the 1.9 K magnet cryostat heat exchanger, for which the study has taken into account the implications of co-current and counter-current two-phase flow. As a consequence, continuity of the pumping line X* between pairs of half-cells has been provided for.

Remarks:

- i) It has been implicitly accepted that independently of any cryogenic sectorisation proposed in this report, the insulation vacuum of the machine cryostats and QRL will be sub-sectorised (see also Sections 2.4, 4 and **Annex IV**).
- ii) Sectorisation of electrical systems (bus bars) has not been considered in this study. It would require bus bars passing through the QRL, with electrical interconnects to the machine elements every half-cell. A simple evaluation shows that this would be relatively difficult and expensive to implement.

The reference naming of the cryolines is the one in the "Yellow Book". It is recalled in **Figures 1 and 2**.

* Note: Refer to Figures 2 and 4 for the designation of the lines.

1.2 Levels of sectorisation

Sectorisation of an LHC arc has to be considered at various levels for the main machine systems (see **Figure 3**):

i) Cryogenics

- a) Separation of the cooling loops between the QRL and the magnet cryostat (parallel feeding).
- b) Sectorisation of the series cryolines in the magnet cryostat (heat exchanger line B and thermal screen line E in series).

ii) Beam and insulation vacua

- a) Sectorisation of the beam tubes.
- b) Sub-sectorisation of the magnet cryostat.

1.3 Short, medium and long interventions (repairs, etc.)

A preliminary analysis of possible faults per system (cryogenics, magnets, vacuum) has been made, including the consequences for the machine operation. Essentially three classes of events can be defined, based on the duration of the intervention for repair (warm-up and cool down not included, see **Annex I**):

- a) Short interventions (typically 4 days), such as the replacement of a protection diode, repair of a valve plug, an electrical or instrumentation feedthrough, etc. These interventions do not require closing of the beam vacua valves or the series cryoline separation valves situated in the Short Straight Sections (SSS). Accordingly, only a limited number of cells, i.e. a sub-sector of the insulation vacuum, need to be warmed up.
- b) Medium interventions (typically 4 days), such as the repair of BPM feedthrough, involving a complete sector to be warmed up and vented to air, which implies that the series circuits (beam vacua, heat exchanger and thermal screen line E) of the magnet cryostat have to be closed at the sector boundaries.
- c) Long interventions (typically 12 days), such as the change of a cryomagnet, involving a complete sector to be warmed up and vented to air, see also b).

The likelihood of short and medium interventions for repairs is larger than for long interventions, if one takes the number of various components and the related degrees of severity of failures into account, see **Annex I**. The different levels of sectorisation must take this into account, for instance, in favouring a finer subdivision of the magnet cryostat chain with shorter insulation vacuum sub-sectors. However, a balance has to be defined, since a larger number of sectors and sub-sectors entails higher costs, and possibly yields a higher risk of hardware failures.

1.4 Installation, quality control and commissioning

In principle, sectorisation opens the possibility to cool down individually smaller sectors of machine systems, hence, early cold checking of components whilst the installation proceeds could be envisaged. This would, for instance, permit fine debugging of systems, such as the localization and repair of cold leaks, short

circuits or poor electrical connections, without slowing down the pace of the installation and/or the commissioning.

Scenarios could also be envisaged where temporary electrical shunts would be installed at the bus bar ends of the string of magnets already installed, thus allowing electrical testing 'in situ' of cryomagnets.

However, these last possibilities will require further studies, such as for instance the cool down of a stretch of magnets without 50 - 75 K shield, and is not covered in this report.

2 SECTORISATION OF THE LHC ARCS

2.1 System layout

The cryogenic system in an arc of the LHC as defined in the "Yellow Book", and which may be divided into sectors, consists of 54 half-cells in each arc:

- a) even point dispersion suppressor, approximately equal to four standard half-cells in length,
- b) forty-six standard half-cells,
- c) odd point dispersion suppressor, approximately equal to four standard half-cells.

Sectorisation should meet the following criteria:

- a) sectors of one system must be more or less identical in length⁽¹⁾,
- b) sectors of different systems may not necessarily be identical in length and have the same boundaries (e.g. cryogenics and insulation vacuum),
- c) the 1.9 K cryogenic level and insulation vacuum must have matching boundaries, in order to minimise the number of half-cells to be warmed up for a short intervention.

With 54 half-cells in an arc, several schemes of sectorisation scenarios satisfying these criteria can be envisaged. An arc may be divided into $n = 2, 3, 4, \dots$ cryogenic and beam vacuum sectors, and $n \times m$ insulation vacuum sub-sectors (see **Annexes II and III** and **Figure 3**).

As an example, and to complete the system description with numbers, the scheme of sectorisation based on $n = 4$ and $m = 3$ is given below.

2.2 Cryogenic sectors

The cryogenic system in an arc of the LHC machine may be divided into four sectors (a - d) of approximately equal length:

- a) even point dispersion suppressor and nine half-cells (13 half-cells),
- b) fourteen half-cells,
- c) fourteen half-cells,
- d) nine half-cells and odd point dispersion suppressor (13 half-cells).

⁽¹⁾ The dispersion suppressor half-cells, comprising only 2 dipoles but having longer inter magnet connections are only marginally shorter than the standard half-cell, especially if one includes Q6 in the arc cryostat.

The equipment defining the boundaries of the cryogenic sector is (see **Figure 4**):

- a) Seven valves in each technical service module of the ring transfer line (QRLS) which allow to shut off the pipes A, B, C and D of the ring transfer line (QRL) from the corresponding volumes in the magnet cryostats (LQ & LB). Five of these valves already exist in the layout of the "Yellow Book".
- b) One pneumatic, locally actuated shut-off valve (FV3) at each sector boundary inside the LQ to interrupt the line E which is cooling the radiation shield of the LQs & LBs.
- c) One pneumatic, locally actuated shut-off valve (FV4) at each sector boundary inside the LQ to interrupt the helium II heat exchanger in case of the "counter flow" heat exchanger scheme.

The superfluid helium volumes are subdivided by plugs in the bus bar tubes in the intermagnet gaps (interconnects). The bus bar plugs are fitted at full cell intervals, independently of any sectorisation.

The individual pipes of the QRL cryoline are not sectorised as they serve as common supply and return lines.

2.3 Beam vacuum sectors

For the sectorisation scheme of $n = 4$, each beam tube will have to be divided into four sectors. The sector boundaries coincide with the boundaries of the cryogenic sectors and consist of vacuum valves installed in the LQs which house the shut off valves for line E and the helium II heat exchanger (see **Figure 4**).

The so-called cold sector valves defining the sector boundaries for the beam vacua, are of all metal construction and equipped with an RF bridge. These manual valves are only operated when at room temperature once the adjacent magnets have been force warmed and the insulation vacuum vented. The manual operation is performed via an access port in the cryostat vessel. The technical feasibility of such devices has been demonstrated by specialised UHV valve manufacturers (see **Figure 5**).

2.4 Insulation vacuum sub-sectors

The insulation vacua of the magnet cryostats and the QRL will have to be sub-sectorised by the use of so-called vacuum barriers. Three types of such barriers are needed (see **Figure 4**):

- a) Cryomagnet vacuum barrier: for longitudinal subdivision of the insulation vacuum of the magnet cryostat chain.
- b) Jumper connection vacuum barrier: for separation of the cryomagnet and the QRL insulation vacua.
- c) QRL vacuum barrier: for longitudinal subdivision of the insulation vacuum of the QRL.

In the following the role and the disposition of the insulation vacuum barriers are outlined.

i) Cryostat insulation vacuum sub-sectorisation, independent of cryogenic sectorisation

Independent of the cryogenic sectorisation, insulation vacuum sub-sectorisation by means of vacuum barriers is required for the following reasons:

- a) staged pump down,
- b) staged leak testing,
- c) leak localisation,
- d) containment of accidental loss of vacuum,
- e) containment of helium leaks,
- f) local interventions.

This insulation vacuum sub-sectorisation scheme foresees complete separation of the cryomagnet and QRL vacua. The maximum length of one insulation vacuum sub-sector of the cryomagnets has been fixed at 4 half-cells or equivalent (see section 4 as well as **Annexes III and IV**). Each sub-sector for the magnet cryostat insulation vacuum can be connected to its neighbour(s) with a by-pass manifold equipped with a shut-off valve. This feature allows pumping of more than one sub-sector with a single pumping unit.

ii) Additional cryostat insulation vacuum sub-sectorisation, needed for cryogenic sectorisation

The role of the additional vacuum barriers is to:

- a) separate the warm and cold zones of the sector when a vacuum enclosure must be opened to ambient air, so as to avoid condensation at the cold zones,
- b) separate the vacuum quality of the warm and cold zones so as to avoid accelerated warm-up of the cold zones by gaseous heat transfer,
- c) minimise the number of magnets to be force-warmed for all types of interventions.

Integration of the requirements listed in i) and ii) results in only small modifications to the former. For the scheme of $n = 4$, only 1 additional insulation vacuum sub-sector per arc would be required to implement cryogenic sectorisation, optimised for short interventions.

In summary, the insulation vacuum of the magnet cryostat and the QRL is separated by vacuum barriers in the jumper connections of the QRL. The maximum length of one insulation vacuum sub-sector in the magnet cryostats is four half-cells. Each dispersion suppressor represents one insulation vacuum sub-sector. The magnet cryostats in an arc are subdivided into fifteen insulation vacuum sub-sectors, i.e. $(n \times m) + 3 = (4 \times 3) + 3 = 15$, as shown in **Annex III**.

iii) QRL insulation vacuum sectorisation

The QRL insulation vacuum is separated from the magnet cryostat by means of vacuum barriers situated at each half-cell jumper connection, to allow independent commissioning and acceptance of the QRL. Consequently, LHC machine elements can be connected to the previously installed line without breaking its insulation vacuum, which is to be guaranteed by the supplier over a period of two years.

The QRL insulation vacuum is subdivided every 420 metres approximately, which corresponds to the length of eight half-cells. This subdivision will allow stepwise conditioning during installation. It will also limit the heat load to the fluid pipes in case of a local vacuum deterioration and facilitate leak testing.

In case of an accidental venting of the vacuum envelope with air due to damage from outside or flooding with helium due to rupture of an inside bellows, the total heat inleak will be limited to the corresponding QRL sector length. This sectorisation will also permit to limit the required safety relief devices to a reasonable size.

The subdividing of the QRL insulation vacuum, however, is independent of the sectorisation philosophy described in the present report.

3 CRYOGENICS (scenarios, etc.)

3.1 Warm-up of one sector (13-14 half-cells) for a long intervention

This concerns all interventions for which either the thermal shield line E in the magnet cryostats or the beam vacuum tubes have to be opened to atmosphere, e.g. exchange of a magnet or part of the beam line.

The warm-up of a sector from normal operation conditions will be done in the following sequence (see also **Figure 4**):

- a) Closing of the five remote controlled valves in each of the QRL jumper connections supplying the half-cells which are not to be warmed up.
- b) Closing of the two remote controlled isolation valves for line E in the underground interconnection box (QUI) and the ring tunnel feed box (QRF).
- c) De-pressurisation of line E of the thermal shield to 1 bar.
- d) Evacuation of line E to ≤ 1 mbar to prevent heat transport by convection.
- e) Warming up of the cold masses, the beam screens and the heat exchanger tube in the sector and the single adjacent cell(s) which are to be warmed up by forced flow of warm helium from the QRL. The QRL is warmed up over its whole length.
- f) Controlled flooding with dry nitrogen of the insulation vacuum of all sub-sectors of the magnet cryostat in the sector to which access is needed. This prepares the opening of part of the sector and ensures the warm-up of the thermal shield which cannot be warmed actively.
- g) After reaching ambient temperature, opening of the magnet cryostats which house components to which access is needed.
- h) Closing of the isolation valves FV3 at the cryogenic sector boundaries in line E (if these valves are accessible from outside the vacuum enclosure they may be closed directly after evacuating line E).
- i) Closing of the isolation valves FV4 in the helium II heat exchanger (if installed).
- j) Closing of the beam tube sector valves, VVS1 and VVS2.
- k) Closing of all the manual isolation valves FV1 and FV2 connecting the half-cell to line C and B in the cryostats in which the helium volumes are opened to atmosphere. The sectors which have not been warmed up are left floating in temperature during the intervention.

3.2 Cool down of one sector (13 or 14 half-cells) after a long intervention

When all the pipes which were opened have been reconnected and successfully leak checked, the sector can be cooled down.

- a) All volumes for helium gas which were exposed to ambient have to be purged. The purge operation is done by evacuating lines C and A in the QRL and connecting the helium volumes which were opened to ambient using the relevant remote controlled valves in the QRLS. Line E is purged by use of appropriate purge connections in the SSS.
- b) All valves which can only be accessed inside the cryostats are opened.
- c) The cryostats which were opened or flooded with nitrogen are closed and the insulation vacuum is re-established.
- d) Line E is reconnected to the system by opening of the two remote controlled isolation valves for line E in the QUI and the QRF.
- e) The warm cryomagnets are then cooled down using the lines A, B, C, D, E and F in the magnet cryostats and the QRL.
- f) As soon as these cryomagnets have the same temperature as the rest of the arc, the five remote controlled valves in each of the interconnects to the half-cells which were not warmed up are opened and the complete sector is cooled down to operation conditions.

3.3 Warm-up of one sub-sector for a short intervention

This concerns all interventions for which neither the thermal shield line E in the magnet cryostats nor the beam vacuum tubes have to be opened to atmosphere, e.g. exchange of a dipole corrector lead, a cold diode or an instrumentation feedthrough.

The warm-up of a sub-sector from normal operation conditions will be done following the same sequence as in Section 3.1, a) to g).

The sub-sectors which were not warmed up are left floating in temperature during the intervention on the warmed up part.

3.4 Cool down of one sub-sector after a short intervention

When all the pipes which were opened have been reconnected and successfully leak checked, the sector can be cooled down.

- a) The cryostats which were opened or flooded with nitrogen are closed and the insulation vacuum is re-established.
- b) Line E is reconnected to the system by opening of the two remote controlled isolation valves for line E in the QUI and the QRF.
- c) The warm cryomagnets are cooled down using the lines A, B, C, D, E and F in the magnet cryostats and the QRL.
- d) As soon as these cryomagnets have the same temperature as the rest of the arc, the five remote controlled valves in each of the interconnects to the half-cells which were not warmed up are opened and the complete sector is cooled down to operation conditions.

3.5 Protection against overpressure

The sectorisation of the cryogenic piping creates the inherent possibility to close volumes of entrapped cold cryogenic fluid which in case of an uncontrolled warm-up may provoke a dangerous pressurisation. The build-up of high pressures is avoided according to the concept lined out below:

- a) The two additional shut-off valves FV1 and FV2 in the Technical Service Module (QRLS) of the QRL which create a closed volume of the beam screen and the two phase helium II piping will be closed pneumatically against a given spring force, which guarantees opening at a certain differential pressure over the valve seats. This allows to blow off pressurised gas into line C, respectively B. The set pressure for these valves is to be determined.
- b) Line E is sectorised by fully “immersed” valves in the QQS. These valves are designed such that they can only be actuated after opening of the vacuum tank of the QQS. Thus, helium can only be entrapped at ambient temperature and, in principle, not create an overpressure. The only imaginable way to reach a hazardous situation may occur with a partial cool down of the thermal shield where helium is trapped in line E because of a leaking shut-off valve and due to radiation from the cold mass. In this case a sudden vacuum break-down would cause over-pressurisation of line E. To avoid this, the actuator supply lines can be fitted with a spring loaded relief device, which limits the closing pressure and allows opening of these valves at a certain pressure difference over their seats.
- c) The valves FV4 in the helium II heat exchanger pipe, which have to be installed in case of the “counter flow” scheme, do not need to open at overpressure as these volumes are secured by the shut-off valves TCV1 and FV1 in the QRLSs.

3.6 Purging and pressure testing

As already mentioned, the line E in the magnet cryostat has to be equipped with a suitable connection to allow purging and pressure testing of its sectorised length. These connections are to be located close to the cryogenic sector valves FV3 in the QQS interconnection region.

All other helium volumes on which an intervention has been made will be purged and pressurised together with the corresponding lines in the QRL.

The enclosure for pressurised helium II and the beam screen line will be purged and pressurised via line D through an SRV respectively a TCV2. The volume for two phase helium II will be purged and pressurised via line A through a TCV1.

It should be noted that the beam screen and the two phase helium II volumes are closed off by valves with a safety relief function. The maximum pressure during testing must not reach the opening pressure of these valves to prevent contamination of other lines.

3.7 Cool down and warm-up times

The times for cool down and warm-up are calculated according to the following formula:

$$t(T) = \int_{T_{\text{cold}}}^{T_{\text{warm}}} \frac{M \cdot c_{\text{mass}}(T)}{Q(T)} \cdot dT$$

with: M = mass to be cooled / warmed
 c_{mass} = specific heat capacity of M
 Q = available refrigeration / warm-up capacity.

The mass to be cooled down or warmed up depends on the length of the magnet string, i.e. sector. The specific heat capacity can be taken from existing property data. The available capacity is limited by several factors.

i) Limits for the available capacity

Maximum cooling and heating capacity

The maximum cooling capacity specified in the contract of the existing LEP machines for the external LN2 cooling was 300 kW. The cool down capacity of the LHC plants for temperatures below 90 K is not exactly known and was extrapolated from the data for the 12 kW LEP refrigerators. The maximum heating capacity is taken as 300 kW per refrigerator.

Maximum compressor flow

The maximum LP (low pressure) compressor flow will be between 720 and 850 g/s. According to the calculations for the existing plant, 800 g/s can be passed through the cold boxes at 300 K (beginning of cool down, end of warm-up) with a pressure drop of 3.5 bar at the HP (high pressure) as well as the LP side.

Maximum flow for one cell

The LHC magnet cryostats will always be cooled or warmed in entities of complete cells, since the cold masses of each cell are hydraulically divided into loops by means of the bus bar plugs. The maximum flow possible to be passed through a cell is 100 g/s.

Maximum pressure drop in the piping of the cryogenic distribution line

The pipe diameters in the cryogenic distribution line (QRL) are fixed. This limits the maximum mass flow that can be passed through this line.

ii) Assumptions for the calculations

The calculations are done according the following assumptions:

- a) The maximum mass flow which can be supplied by the refrigerator for the cool down and warm-up of the LHC machine is 770 g/s, corresponding to a maximum capacity of 300 kW under a ΔT of 75 K.
- b) The maximum flow that can be passed through one cell is 100 g/s.
- c) The inner pipe diameters involved in the cool down and warm-up processes are:
 - 100 mm for pipe C
 - 150 mm for pipe D
 - 80 mm for pipe E
 - 80 mm for pipe F.
- d) Existing connections between pipe F and pipe C in the middle of each arc and between the pipes C, E and F at the odd end of an arc, are used for the cool down and warm-up above 80 K.
- e) The time for a long intervention including purging and leak checking is 12 days between warm-up and cool down.
- f) The time for a short intervention including purging and leak checking is 4 days between warm-up and cool down.
- g) The insulation vacuum in the "floating" part of the sector is maintained at 10^{-6} mbar.

The resulting down-time depending on the degree of sectorisation for a long intervention is listed in Table 1. The first column shows the results which can be obtained without sectorisation; the others give the results for two and four sectors. The operation mode "fast WU / CD" is performed by coupling two refrigerators to supply one cryogenic sector, whereas the operation mode "normal WU / CD" uses only one refrigerator per cryogenic sector. For the operation with one refrigerator per sector the limit for cool down and warm-up is in all cases given by the maximum capacity of the refrigerator. For the operation with two refrigerators per sector the limit for cool down and warm-up is given either by the pressure drop in the supply lines of the QRL, which applies in particular for the cryogenic sector most remote from the refrigerator, or by either the maximum capacity or the maximum flow which can be passed through the cells to be warmed or cooled. The down-time therefore depends on the cryogenic sector on which the intervention is done. Table 1 lists the values for the maximum and minimum down-times. **Figures 6 and 7** give a graphical representation of the expected down-times for various scenarios.

The down-time for a short intervention is independent of the degree of sectorisation and results in all cases in a total of 17 days, provided that access is needed only to the insulation vacuum and to the volume for pressurised helium II. This results from the fact that in all cases the limiting factor for the capacity is the maximum flow that can be passed through a cell.

Table 1:
Calculated down-time for the LHC machine (long interventions = 12 days)
depending on the degree of sectorisation

Number of sectors		1		2			4		
Operation mode		normal WU/CD	fast WU/CD	normal WU/CD	fast WU/CD min	fast WU/CD max.	normal WU/CD	fast WU/CD min.	fast WU/CD max.
Warm-up time	[d]	16.6	9.4	10	5.7	8.4	6.7	5.2	5.8
Intervention time (long)	[d]	12	12	12	12	12	12	12	12
Cool down-time to T rest	[d]	0	0	11.5	6	7.8	7.5	4.9	5.3
T rest	[K]	300	300	65	58	60	60	57	58
Cool down-time to 1.9 K	[d]	24	12.8	4	2.4	2.5	3.5	2.3	2.4
Total time for WU/CD	[d]	40.6	22.2	25.5	14.1	18.7	17.7	12.4	13.5
Total down-time	[d]	52.6	34.2	37.5	26.1	30.7	29.7	24.4	25.5

3.8 Additional cryogenic equipment

A possible sectorisation of the LHC machine arcs will ask for additional valves to be placed inside the QRLS connecting the helium supply and recovery manifolds to the half-cell loops, as shown in the half-cell flow scheme (see **Figures 2 and 4**). Further valves must be added to the Technical Service Module of the quadrupole cryostats (QCS) which are situated at the interface between sectors. A cut-away view of the interconnection region shows the integration of the valves (see **Figure 8**).

To minimise additional heat load to the fluid lines, the valves are placed inside the thermal shield, fully immersed into the insulation vacuum, with thermalised capillaries to room temperature for the pneumatic actuators which are kept under sealed-off vacuum when under normal operation, thus avoiding thermo-acoustical oscillation. Under normal operating conditions of the LHC machine all cryogenic sectorisation valves are in their fail safe, open (pressure to close) position. All valves which need to be closed for an intervention will only be manipulated when at room temperature, which should avoid any blockage at cryogenic temperatures and should, therefore, not affect the reliability of the collider operation.

i) Cryo-equipment to be installed into the QRLS

To allow a total isolation of the cooling/pumping loops branching into the half-cells from the QRL manifolds, each QRLS must be fitted with two additional shut-off valves with associated auxiliary equipment for the drive of pneumatic actuators from outside (see **Figure 8**):

- a) 1 angular valve DN 50/PN 10 situated in the pumping line between the 1.9 K phase separator and line B,
- b) 1 angular valve DN 15/PN 25 situated in the 4.5 K LHe supply line C.

These valves are combined with incorporated spring loaded safety relief check valves operated by a possible pressure rise in the enclosed piping volume, depressurising the concerned circuit to the corresponding QRL manifold. The built-in check valves are recognised safety devices as they do not require any auxiliaries, but they cannot be reset (calibrated) periodically during operation.

Design features of the valves can be seen in **Figure 9**.

ii) Cryo-equipment to be installed into the QQS

For the separation of cryogenic piping of the sectors, two more valves are to be installed at their interfaces and placed into the QQS interconnecting region. In view of the limited space available, coaxial shut-off piston valves are proposed, pneumatically operated from outside or from inside the interconnect after warm-up, and venting/opening of the vacuum enclosure:

- a) 1 coaxial piston valve DN 80/PN 25 mounted to the screen supply line E,
- b) 1 coaxial piston valve DN 60/PN 10 mounted to the 1.9 K counter flow tubes X.

Design features of the valves can be seen in **Figure 10**. These all-welded streamlined valves have a low pressure drop and can easily be integrated without any modification to the pipework layout.

4 VACUUM (scenarios)

4.1 Pumping

i) Insulation vacuum

Mechanical pumping of the insulation vacuum is required for the following scenarios (see **Annex IV** for further details):

- a) Evacuation from atmospheric pressure to 10^{-2} mbar.
- b) Pumping to maintain 10^{-2} mbar, awaiting cool down.
- c) Pumping of large helium leaks during LHC operation.
- d) Pumping to minimise warm-up of floating sub-sectors and sectors.
- e) Pumping to minimise warm-up at interruption of the cryogenic plant.

The positive displacement pumps (and their controls and cabling) required for items a), b) and d) are necessary independently of cryogenic sectorisation, as are the turbomolecular pumps for item c).

It is assumed that adjacent insulation vacuum sub-sectors of the cryomagnets and the QRL, may be pumped by a common pumping unit.

The turbomolecular pumps required at d) are only applicable for cryogenic sectorisation, and are costed at 1.2 MCHF and 0.6 MCHF for permanent or mobile pumps respectively (see **Annex V**).

ii) Beam vacuum

Pre-evacuation of the beam tubes is foreseen with mobile turbomolecular pumping groups. At a pressure of 10^{-6} mbar the permanently installed ion pumps can be started, and remain on whether the LHC arcs are warm or cold.

At warm-up to room temperature, the mobile turbomolecular pumping groups may be used to limit the amount of gas pumped by the ion pumps, hence increasing their lifetime.

4.2 Venting of vacuum sectors

The venting scenarios are described in Section 3. Venting of insulation vacuum sub-sectors (typically of 40 m³) shall be made with piped dry nitrogen gas. In order to avoid damage to superinsulation, all venting apertures shall be flow restricted. Each vacuum sub-sector is equipped with an overpressure valve.

Venting of beam vacuum sectors may be made with bottled or piped dry nitrogen gas.

4.3 Leak testing

Leak testing of vacuum enclosures at LHC installation or subsequent interventions is made in 3 steps:

- a) Individual room temperature leak testing of all new joints, with the respective helium circuit pressurised.
- b) Global room temperature leak testing of the beam vacuum sector or insulation vacuum sub-sector by evacuation of the enclosure and pressurisation of the helium circuits.
- c) Global cold leak testing of each insulation vacuum sub-sector during cool down of the arc.

During global testing any leaks can be identified to their insulation vacuum sub-sector. Separation of cryomagnet and QRL insulation vacua allows time-of-flight leak localisation methods to be used.

Cryogenic and vacuum sectorisation may allow staged cold leak testing of both beam and insulation vacuum enclosures before completion of the arc.

5 COST ANALYSIS

Cost estimates for the additional equipment needed in case of $n = 4$ sectors per arc are given in **Annex V**. In addition, this annex contains some rough estimates of the cost of lost physics time due to unforeseen shutdowns.

5.1 Cryogenic system

The additional cost for the cryo-system is estimated at some **4.5 MCHF**, or about 2/3 of the gross total. The bulk of this amount would be spent on additional valves needed in the return line B (phase separator) and the feeder line C (4.5 K for beam screen and support posts) in each half-cell. This equipment is indispensable for long interventions.

5.2 Vacuum systems

The additional cost for the vacuum systems (insulation and beam vacua) is estimated at some **2.1 MCHF**, and accordingly about 1/3 of the gross total. The ratio between the estimated additional cost for the insulation and the beam vacua is roughly 50/50, hence, shared between the equipment needed for short and long interventions. However, it should be noted that insulation vacuum pumps (estimated at **0.6 MCHF**) may well serve the purpose of maintaining the insulation vacua (QRL included) independent of any sectorisation for the cases of large helium leaks or stoppages of the cryogenic plant (see 4.1.i).

5.3 Grand total

The grand total of the capital investment needed for the additional equipment in case of sectorisation with $n = 4$ cryogenic and beam vacuum sectors per arc is estimated at roughly **6.6 MCHF**.

The grand totals of the capital investment for the additional equipment needed for a sectorisation with $n = 2$ or 3 cryogenic and beam vacuum sectors per arc are estimated at roughly **4.90 and 5.95 MCHF** respectively.

5.4 Savings (cost of lost physics time)

Obviously, estimates under these headings are difficult to make. Nevertheless, an ECFA study carried out in 1988 aimed at quantifying the cost of a physicist when he/she is working with experimental physics at CERN, ref. "The ECFA Survey of Particle Physics Activities and Resources in the CERN Member States", ECFA/RC/90/178 of 90.03.30. The existing figures, which are claimed to have an error margin of 30%, have been used to try and estimate likewise the cost of a physicist who is idle due to unforeseen shutdowns of the accelerators. It is implied that 'idle' means that the down-time is of such duration that the majority of the personnel involved in, for instance an LHC experiment, can not continue to do work directly related thereto. The cost of a "declared visiting external physicist", including supporting CERN staff, then averages 9'300.- CHF/month.

The number of declared visiting external physicists who will be present at any time at CERN working with LHC can be left to speculations. The conclusion should rather be that the estimated capital investment for the sectorisation of LHC corresponds very roughly to possible savings for the external users, in terms of salaries, of some 700 physicist-months.

With four sub-sectors per arc, the reduction in the down-time resulting from a long intervention will be up to 23 days, whilst the down-time of 17 days resulting from a short intervention will not be affected by the sectorisation, (see **Figure 6**). With the above given figure, break-even could be reached with, for instance, some 350 external users affected during two down-time periods resulting from long interventions.

Obviously, these estimates should be used with great care, but the order of magnitude of the figures given are probably correct. No attempt was made to try and estimate the value of energy savings on the one hand or to evaluate the loss of interest rate of the total capital investment, etc. on the other hand, not to mention the possible loss of credibility and goodwill in the users community.

6 DISADVANTAGES OF SECTORISATION

This concerns mainly cryogenics.

Firstly, the additional "secondary" valves in the service modules of the QRL add complexity to the "primary" components for which only limited space is available. Their impact on the overall reliability could be a problem.

Secondly, operating a cryogenic installation in which cold parts and parts connected to atmosphere are only separated by valves, especially if these have a fail open position, always incorporates the risk of contaminating the whole system. Judging only from the point of view of operation of the cryogenic system it may, therefore, be preferable to always warm-up a whole LHC arc in case of repairs on parts of it. The same argument applies when considering a possible benefit like staged cold testing during commissioning.

7 CONCLUSION AND FURTHER WORK

For a marginal cost compared to the total capital investment of LHC, a complete cryogenic and vacuum sectorisation of the arcs is proposed.

This sectorisation allows to reduce the down-time of the LHC for interventions on all machine volumes which are not already sectorised according to the reference scheme of the "Yellow Book". Especially the down-time for long interventions, such as the exchange of a cryomagnet, will be considerably reduced in the case where it is not possible to combine two refrigerators for the cool-down of one LHC arc.

The additional hardware required (passive valves and vacuum barriers) will have a marginal influence on the cryogenic load. Their impact on the reliability of the machine operation should be negligible, although this has yet to be proved.

In case of a positive decision for a more complete cryogenic and vacuum sectorisation, as proposed in this report, further work would be required for the detailed specification of all the additional hardware. The possible benefits like staged cold testing of LHC sectors during commissioning should also be further examined.

CRITICAL ITEMS IN THE ARCS OF THE LHC MACHINE

Item description	Number	Failure type	Severity	String	LEP	HERA	Tevatron	RHIC
Magnet and cold masses					6 years	6 years	13 years	2 sextants installed
Main magnets	2000	defective/shorted	<i>1</i>			3/632 (1)	205/400	
Correctors	10000	defective/shorted	<i>1</i>			?		
Current leads/bus bars/interconnects	24000	shorted/open	<i>1 (2)</i>			1 (3)		
Diodes	2000	defective	<i>2 (1)</i>			5/632		
Feedthroughs/capillaries	6000	leaking	<i>2 (1)</i>	1 (3)	16/6826 0.25%	2% (3)		
Voltage taps/diagnostics	150000	shorted/open	<i>3 (2 - 1)</i>	1 (3)		3 (2)		
Cryogenics , cryostats and vacuum								
Bellows	7000	leak	<i>3 (2 - 1)</i>	1 (3)	6/2649 0.2%			
HTcS leads of dipole correctors	1728	broken/leak	<i>2 (1)</i>					
Main HTcS leads	800	broken/leak	<i>2 (separate box)</i>					
Instrumentation (sensors)	10000	broken/misreading	<i>3 (redundancy)</i>			1 (2)		
Piping (welds)	220 km ~50000	leak	<i>3 (2 - 1)</i>		2/15000 0.01%	0.2%		3/1200 (leaks on manual welds only)
Quench relief valves	648	blockage/leak	<i>3 (2-1)</i>	1 (2)				
Valves	1296	blockage/leak	<i>3 (2-1)</i>					

Notes: Numbers in italic or in parenthesis indicate the degree of severity:

- (1) Entails an immediate machine stop, warm-up and a long intervention e.g. change of cryomagnet with complete sector warm-up + 12 days work
- (2) Means a full sector warm-up and a medium intervention e.g. change of a valve plug with complete sector warm-up + 4 days work
- (3) Means a local warm-up and a short intervention e.g. change of diode with a few cells warm-up + 4 days work

HERA has had at least 2 faults of level (1) with at least 20 days of physics lost in 1995

LEP has had at least 3 faults of level (1) with 16 days of physics lost

TEVATRON has had many faults of level (1)

Several short and medium interventions could possibly wait scheduled technical stops or shutdowns.

LISTING OF POSSIBLE CRYOGENIC AND VACUUM SECTORS (n)

An arc together with the dispersion suppressors consists of 54 half-cells, of which 46 are standard arc half-cells of 53.5 m unit length and 8 are somewhat shorter non-standard half-cells. The total ("Arc Cryostat", as defined in the "Yellow Book") may be split up into several (n) cryogenic and vacuum sectors. With $n > 2$ the arc proper would naturally become one or several "central" sectors, bounded by the dispersion suppressors each forming an "even" and an "odd" sector.

	n = 2	n = 3	n = 4
Cryogenic and vacuum sectors			
<u>Even sector:</u>			
Number of half-cells	27	18	13
Length (meters)	1444.5	963	695.5
<u>Central sector(s):</u>			
Number of half-cells	-	1	2
Length (meters)	-	18	2x14
		963	2x749
<u>Odd sector:</u>			
Number of half-cells	27	18	13
Length (meters)	1444.5	963	695.5
Insulation vacuum sub-sectors			
<u>Even sector:</u>			
Number of insulation vacuum sub-sectors	7	5	4
Number of half-cells per sub-sector	4	4	4
Length (meters)	214	214	214
Number of insulation vacuum barriers	7	5	3
<u>Central sector(s):</u>			
Number of insulation vacuum sub-sectors	-	5	4
Number of half-cells per sub-sector		4	4
Length (meters)	-	214	214
Number of insulation vacuum barriers	-	5	4
<u>Odd sector:</u>			
Number of insulation vacuum sub-sectors	7	5	3
Number of half-cells per sub-sector	4	4	4
Length (meters)	214	214	214
Number of insulation vacuum barriers	6	4	3
Total number of insulation vacuum barriers per cryostat arc	13	14	14
Number of additional insulation vacuum barriers due to sectorisation	0	1	1

INSULATION VACUUM PUMPING

1 MECHANICAL PUMPING OF THE INSULATION VACUUM

a) Evacuation from atmospheric pressure to 10^{-2} mbar:

Evacuation of LHC magnet cryostats is foreseen with large capacity positive displacement pumps which will be transported to the required locations. Evacuation of a 2 cell insulation vacuum sub-sector after exposure to ambient air i.e. at installation or following a long shutdown, will be typically 24 hours. Evacuation following venting to dry nitrogen where the sub-sector is not opened will be only a few hours.

b) Pumping to maintain 10^{-2} mbar, awaiting cool down:

Each room temperature vacuum sub-sector will be maintained at a pressure of 10^{-2} mbar using small capacity positive displacement pumps, which may be permanently installed. The pumps will be isolated from the cryostat once cool down begins. Subsequent cryopumping will reduce the pressure to $< 10^{-6}$ mbar.

c) Pumping of large helium leaks during LHC operations:

If significant helium leaks arise during LHC operations, which cannot be cryopumped, turbomolecular pumping would be necessary to maintain an acceptable insulation vacuum pressure, until a repair could be made during a scheduled shutdown. The vacuum barriers limit the degraded zone and defines the sub-sector to be pumped. Although probable, with approximately 5000 in situ welded helium to vacuum joints per arc the number, size and position of such leaks cannot be predicted, so it is not presently foreseen to install turbomolecular pumps for this application on any of the 15 vacuum sub-sectors of each arc at LHC installation.

Moreover, as a leak is most likely to occur at a magnet interconnect within the superinsulation blanket, further studies may show that it will be necessary to place the turbomolecular pump as close as possible to the leak and adapt the cryostat design in order to have an acceptable pumping speed.

d) Pumping to minimise warm-up of floating sectors:

With the implementation of sectorisation, at any intervention, parts of the sector will be force-warmed to room temperature and the remainder left to warm-up naturally (or float). Excessive warming of the floating sub-sectors and/or sectors will have a non negligible effect on the overall cool down-times.

Experiments on the String Test 1 in conjunction with theoretical models show that the warming of the floating sub-sectors is strongly influenced by its insulation vacuum pressure. As cryosorbed gases are released from the warming magnets the insulation vacuum pressure rises, which in turn increases the heat transfer.

Use of positive displacement pumps will limit the pressure to around 10^{-2} mbar. If large quantities of gas from an air leak had been cryopumped, at warm-up the mechanical pumping would avoid condensation or ice on the external surface of the cryostat vessel.

Annex IV

Further more, use of turbomolecular pumps maintaining insulation vacuum pressures below 10^{-5} mbar, will avoid an additional 6.3 or 6.7 days cool down-time (single cryoplant cooling and $n = 4$) for long and short interventions respectively. The turbomolecular pumps could be permanent installations or mobile units. For permanent installation, a total of 15 pumps would be required for each of the 8 machine sectors. If the mobile units are applied, they can be installed during the forced warming period.

Remark:

The solution of physisorbing the gas species onto sieve materials within the cryostats may be possible, for which further studies are to be made.

e) Pumping to minimise warm-up at interruption of the cryogenic plant:

The requirements fall into the above category, and depend on the duration and frequency of cryogenic plant interruptions.

2 CRYOPUMPING WITHIN THE INSULATION VACUUM

a) Cryopumping to maintain 10^{-6} mbar during LHC operations:

Extensive experience with LHC cryostats at CERN shows that even with high outgassing rate materials within the insulation vacuum envelope e.g. multilayer insulation, instrumentation cabling, etc., the cryopumping by the 1.9 K surfaces is sufficient to achieve $< 10^{-6}$ mbar insulation vacuum pressure.

b) Cryopumping of air leaks:

In principle, air leaks should present little problem to a cryogenic system with large pumping surfaces at 1.9 K. Unlike helium leaks the residual pressure in the cryostat insulation vacuum will not rise with time, however, additional local heat loads could occur. Further studies will be made to verify the effects of air leaks on LHC cryostat performance.

c) Cryopumping of helium leaks during the LHC operation:

There is a limited pumping capacity of helium gas on 1.9 K surfaces. The addition of sieve materials, suitable for helium pumping in the insulation vacuum environment is under study. Having pumped only helium, the sieve material may be regenerated at temperatures greater than 30 K (e.g. activated charcoal).

COST ANALYSIS

1 ESTIMATED ADDITIONAL COST, WITH 4 SUB-SECTORS PER ARC

1.1 Cryo-system, per half-cell:	kCHF	kCHF
1 off valve line B - phase separator	3.2	
1 off valve line C (4.5/20 K)	3	
Integration	2.6	
Sub-total 1.1	<u>8.8</u>	
x 54 half-cells x 8 arcs		3802
1.2 Cryo-system, per sector (in addition to half-cells):	kCHF	
1 off valve line E (screen supply)	12.1	
1 off valve supply line 1.9 K	9.6	
Integration	2	
Auxiliary equipment	1	
Sub-total of 1.2	<u>24.7</u>	
x 3 per arc x 8		593
1.3 Cryo-system, "Jumper" connections in 12 of the LSS:		
1 off "Jumper" connection, unit price 8.8 kCHF x 12		106
1.4 Insulation vacuum:	kCHF	
1 off vacuum barrier	14	
1 off by-pass valve and manifold	3.2	
+ associated controls and cabling	12.4	
1 off roughing valve	1	
2 off vacuum pressure gauge units	4	
+ associated controls and cabling	29.3	
Sub-total of 1.4	<u>63.9</u>	
x 1 per arc x 8		511
1 off mobile TM pump, unit price 5 kCHF		
x 15 per arc x 8		600
1.5 Beam vacuum:		
1 off sector valve, unit price kCHF 20 x 2 x 3 per arc x 8		<u>960</u>
GRAND TOTAL		<u><u>6572</u></u>

Annex V

Remarks:

- a) With sectorisation, the hydraulic diameter of the cryogenic feeder line C and, hence, the volume of He may be reduced.
- b) With sectorisation, the coupling of the cryoplants in the even numbered points may become superfluous.
- c) Most of the cost estimates for the vacuum equipment are taken from the "LHC Cost Estimate, A.G. Mathewson Oct '95", (assuming no electronics in the tunnel).
- d) 15 off mobile TM pumps would be the bare minimum needed with four sub-sectors per arc and one single intervention in one of the sub-sectors.
- e) The estimated unit cost of the beam vacuum valves may be reduced with serial production, but supports, etc. will have to be added.

2 COST OF LOST PHYSICS TIME (due to unforeseen shutdowns)

The following estimates are based on information received from G. Lindecker/DSU and M. Nordberg/DSU on 12 December 1995.

2.1 Question

How much does a physicist (declared visiting external user) cost when he is idle due to an unforeseen shutdown of, for instance, LHC?

It is implied that 'idle' means that the shutdown is of such duration that the majority of the personnel involved in an LHC experiment can not continue to do work directly related thereto.

2.2 Model

Cost of shutdown per month
= Salary cost of external user at CERN (1)
+ Salary cost of supporting staff (2),

where;

(1) = (Take home salary) × (Social cost factor)

(2) = (1) × (Average salary of CERN technician: Average salary of CERN physicist)
× (Number of supporting staff per external user)

2.3 Assumptions

- 2.3.1 The take home salary of a visiting external user is CHF 5'000.- per month.
- 2.3.2 The social costs of a visiting user are 20%, i.e. the social factor is 1.2.
- 2.3.3 The ratio of supporting staff at CERN to one visiting external user is 1/10.
- 2.3.4 Even while at CERN, the visiting external user is dependent on his home institute support staff. The ECFA Study of 1988 estimates the ratio of supporting staff at home per physicist to be 0.75.

2.4 Calculation

$$(1) = 5'000.- \text{ CHF/month} \times 1.2 = 6'000.- \text{ CHF/month.}$$

$$(2) = 6'000.- \text{ CHF/month} \\ \times (6'650.- \text{ CHF/month} : 10'290.- \text{ CHF/month}) \\ \times (0.75 + 0.1).$$

Thus, the cost of a 'declared visiting external physicist', including supporting CERN staff, is:

$$(1) + (2) = 6'000.- \text{ CHF/month} + 3'300.- \text{ CHF/month} \\ = \underline{9'300.- \text{ CHF/month}} \text{ (in 1988 figures).}$$

The estimated error margin is 30%.

With presently some 3'300 identified future LHC users and, say, 25% working actively at the experiments at any time, the above cost figure would amount to some 6.5 to 9 MCHF/month (in current value).

SCENARIOS FOR REPAIR OF CRITICAL COMPONENTS IN VIEW OF SECTORISATION

1 CRYOVALVES (see Figure 4)

The complete replacement of a cryogenic valve is, in general, not taken into consideration as defects on the welded valve body are very rare. However, the replacement of a valve plug or the cleaning of a valve seat from contaminations (foreign particles and debris) will be highly probable during the operation period of the LHC machine, especially within its first years. This type of maintenance, or repair, always means that the piping for helium has to be opened to atmosphere.

In the LHC the following cryogenic valves ("primary" valves which are needed independently of the sectorisation described in this report) are fitted in each service module (QRLS) of the cryogenic distribution line (QRLS) as shown in **Figure 2**.

- One inlet valve for the cold masses, CFV;
- One Joule-Tomson valve for the 1.8 K helium circuit, TCV1;
- One temperature control valve for the beam screens, TCV2;
- Two quench relief valves, SRV.

Special attention has to be paid to the valves CFV and SRV as these are connected to the helium II volume, and any leaks across their seats will increase the heat load on the 1.9 K circuit. In order to reduce to a minimum the down-time of the the LHC machine in case of a repair of one of the "primary" valves, it would be necessary to isolate, by means of some additional ("secondary") valves, all the pipes which need to be opened to ambient from the cold masses which should possibly be kept floating.

For a repair on either one of the two "primary" valves CFV or TCV2, a "secondary" valve FV2 would be required in the supply pipes C' for the cooling of the beam screens, since an intervention on these primary valves implies the venting to atmospheric pressure and exposure to air of line C in the QRL.

For a repair on a "primary" valve TCV1, a "secondary" valve FV1 would be required in the return pipe X from the helium II heat exchanger in each half-cell, as well as a sector valve FV4 in each sector of the heat exchanger pipe (for the counter current scheme), since the volume of this pipe X will be exposed air. Consequently, a repair on a valve TCV1 would, therefore, have to conform with the warm-up and cool down scenario for a long intervention.

For repairs on the SRV valves, no "secondary" valves are needed in the QRLS service modules, since these quench relief valves are connected only to the line D.

Remark:

The "secondary" valves in the QRLS service modules have to be easily operable, preferably from the outside of the QRL. Indeed, although the QRL would not be let up to atmospheric pressure during a repair on a primary cryogenic valve, the "secondary" valves need to be closed in all the half-cells which are to be maintained cold (floating).

Annex VI

2 MAGNET PROTECTION DIODES, ETC. (cold mass)

Access to the protection diodes of the main dipoles and quadrupoles is possible via the magnet interconnects, following warm-up and venting to atmospheric pressure of an insulation vacuum sub-sector (2 cells). Since the repair or replacement of a diode requires subsequent opening of the cold mass, the corresponding half-cell must be completely isolated from the QRL by closing the CFV and SRV valves in the adjacent QRLS service modules. No additional ("secondary") valves are needed for this type of intervention.

The above described scenario is valid also for any intervention on the cold mass instrumentation feedthroughs and capillaries.

3 CURRENT LEADS FOR ORBIT CORRECTORS

Although the design of the leads is not yet finalized, it should be possible to access and replace any such defective leads in the Short Straight Sections (SSS) simply by warming up and venting to atmospheric pressure an insulation vacuum sub-sector (2 cells).

Table 2 summarizes the actions needed on the "secondary" cryogenic valves prior to interventions (repairs, maintenance, etc.) on some of the critical components, i.e. valves to be operated preferably from the outside of the QRL and to be kept closed when parts of the system is floating.

Table 2:
Secondary cryogenic and vacuum valves which have to be closed during repair of some critical components

	Intervention on:	FV1	FV2	FV3	FV4	VVS	Duration of intervention
Primary Valves	CFV	-	*	-	-	-	Short
	TCV1	*	*	*	*	*	Medium
	TCV2	-	*	-	-	-	Short
	SRV	-	-	-	-	-	Short
Secondary Valves	FV1	*					Short
	FV2		*				Short
	FV3	*	*	*	*	*	Medium
	FV4	*	*	*	*	*	Medium
	VVS	-	-	-	-	*	Medium
	DIODE	-	-	-	-	-	Short
	Instrument Capillaries	-	-	-	-	-	Short
	Corr. Magnets Leads	-	-	-	-	-	Short
	Corr. Magnets Feedthrus	-	-	-	-	-	Short?
	BPM Feedthrus	*	*	*	*	*	Medium
	Bellows H	-	-	-	-	-	Short
	Bellows C	-	*	-	-	-	Short
	Bellows X	*	*	*	*	*	Medium
	Bellows V&E	*	*	*	*	*	Medium
	Change of Cryomagnet	*	*	*	*	*	Long

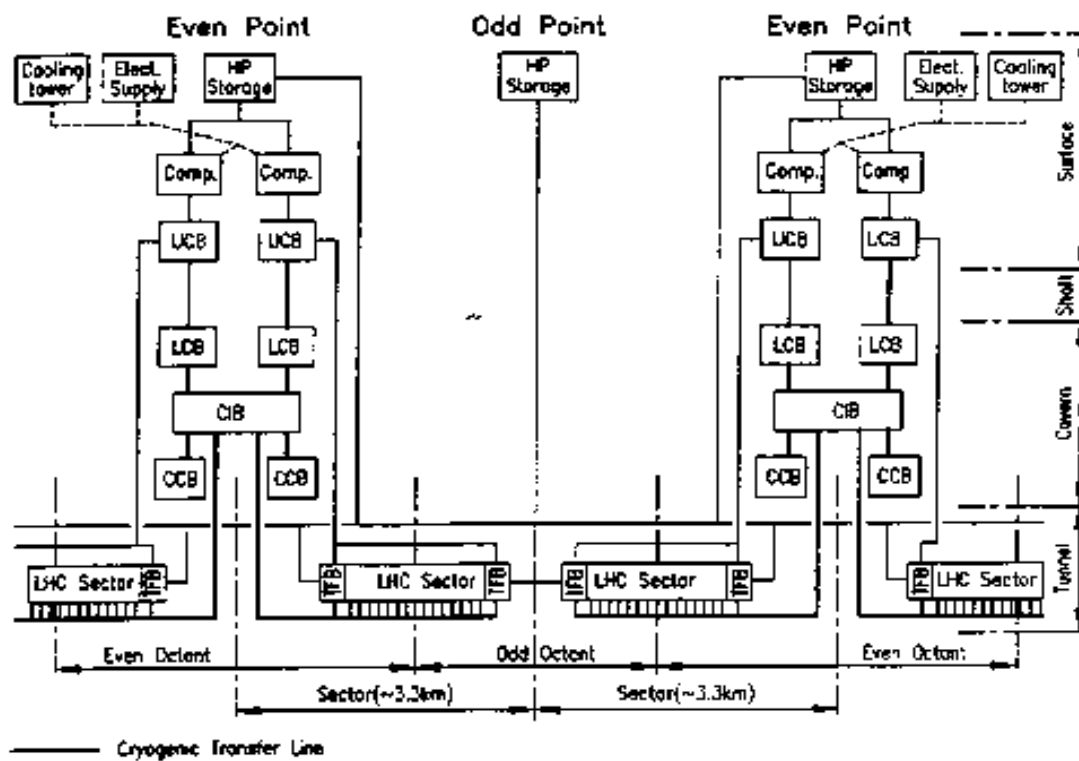

Figure 1: General architecture of LHC cryogenic scheme

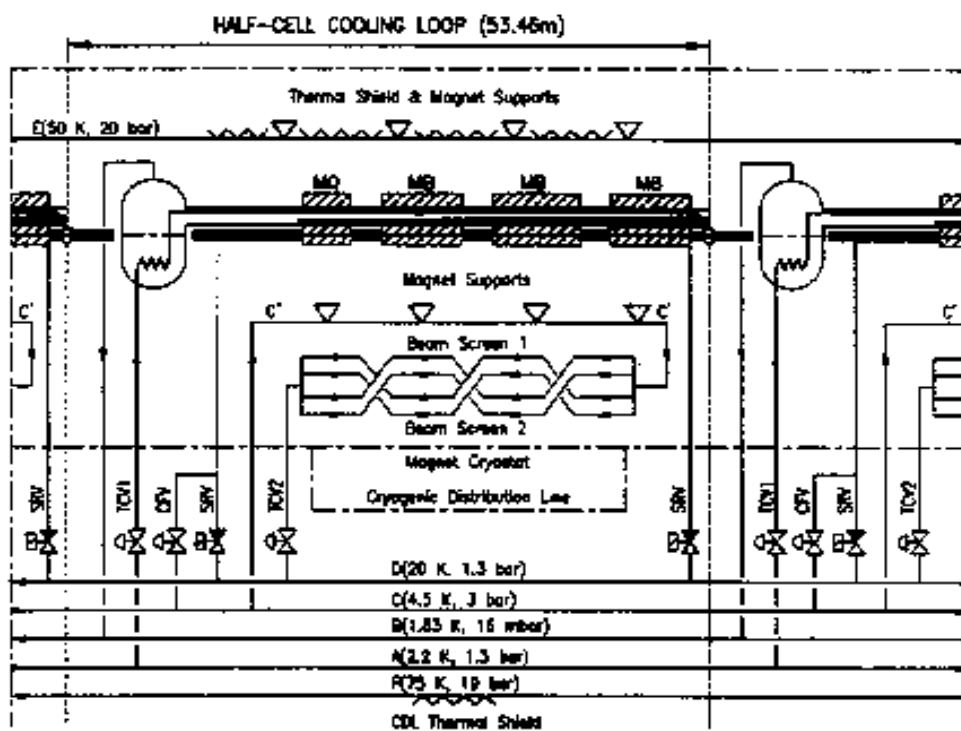
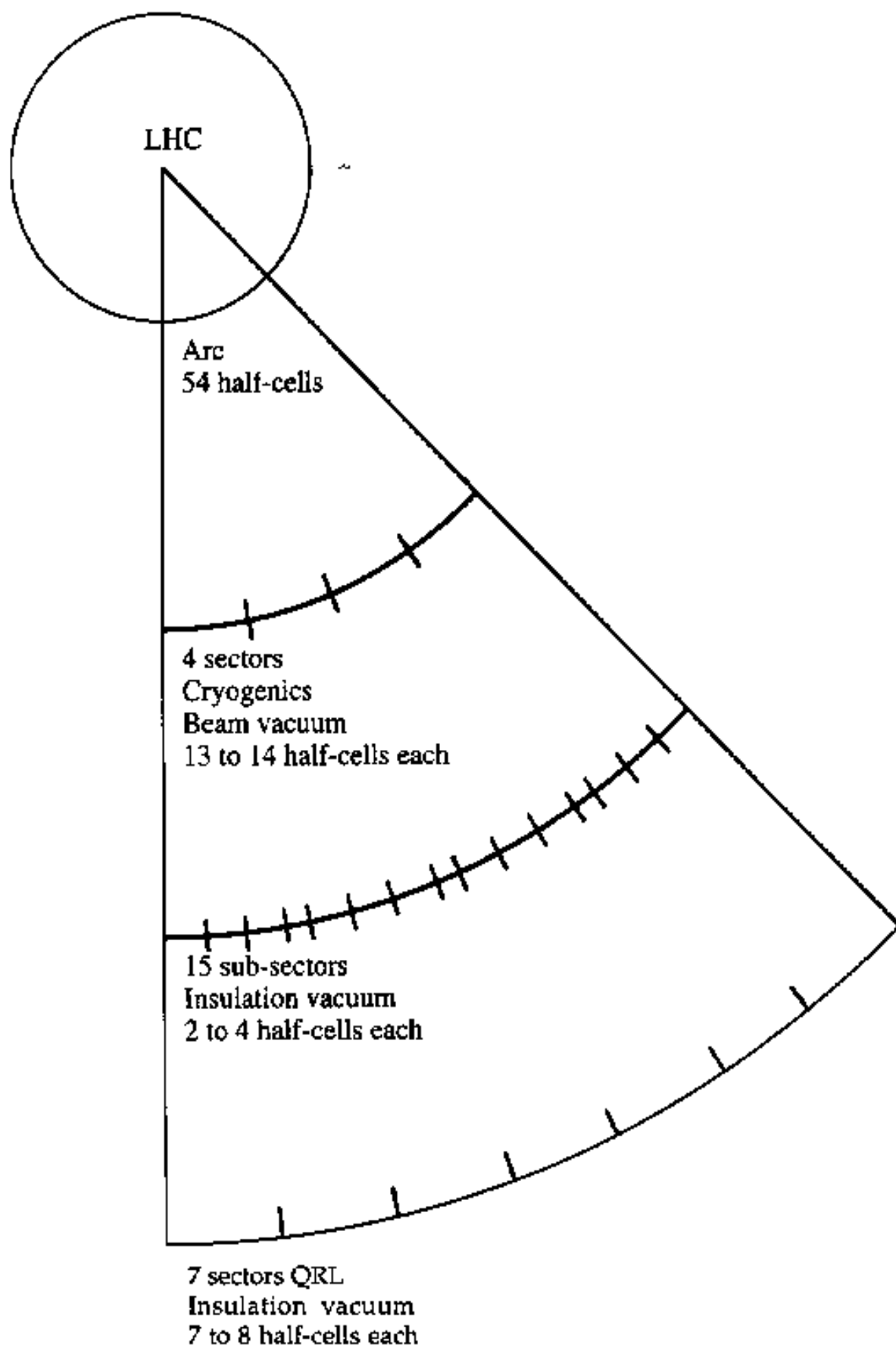
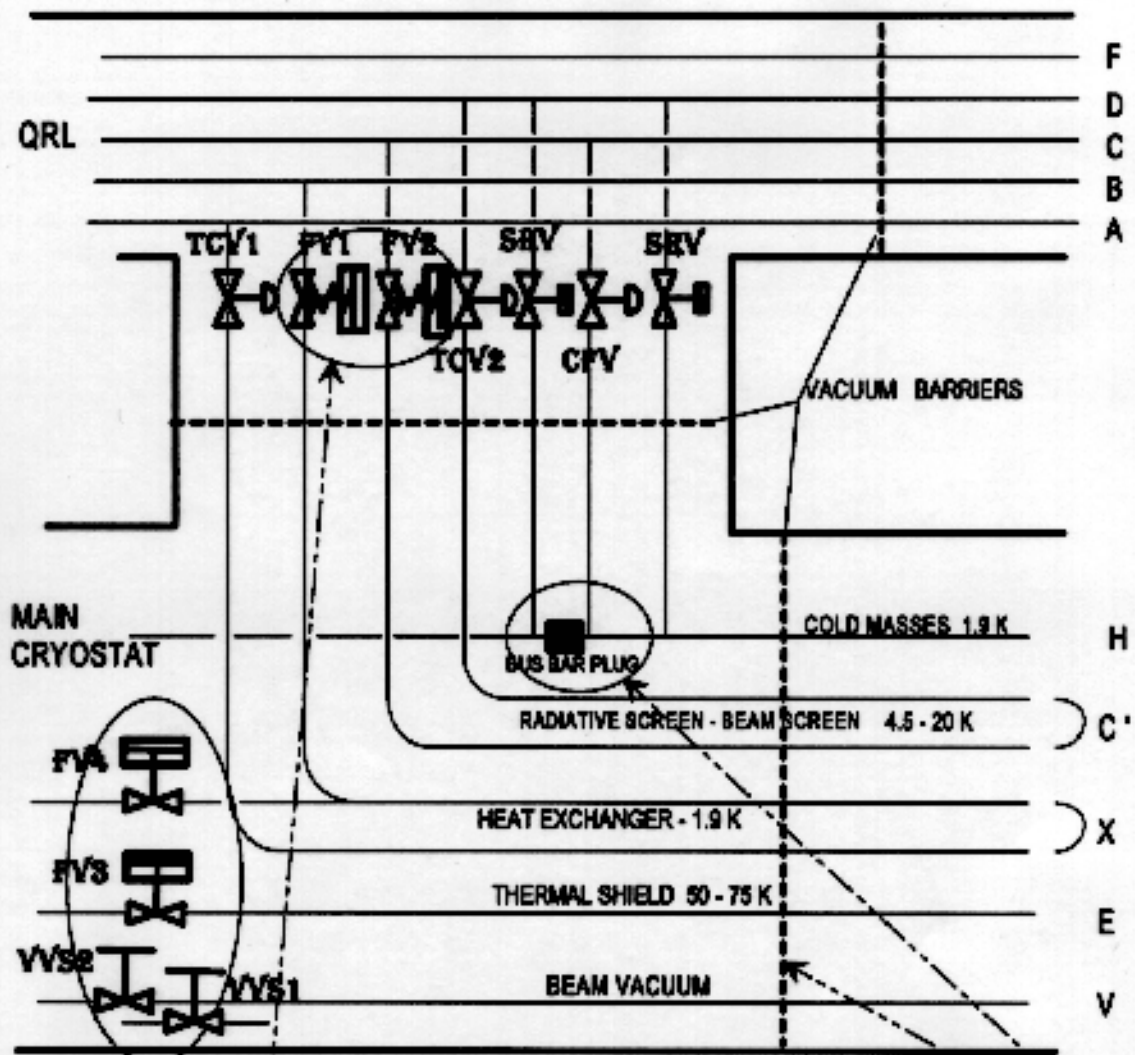

Figure 2: Cryogenic flow-scheme of an LHC half-cell

Figure 3 : Cryogenic and vacuum sectorisation of the LHC arcs





THESE SPRING LOADED - PNEUMATIC OPERATED VALVES HAVE TO BE ADDED AT EACH QRL-CRYOSTAT INTERCONNECT FOR THE PURPOSE OF SECTORIZATION (i.e. 54 TIMES PER ARC)

THESE PNEUMATIC AND HAND OPERATED VALVES HAVE TO BE ADDED AT EACH CRYOGENIC SECTOR BOUNDARY (i.e. 3 TIMES PER ARC, FOR 4 SECTORS)

BUS-BAR PLUGS AND CRYOSTAT VACUUM BARRIERS ARE LOCATED IN THE SAME INTERCONNECT, RESPECTIVELY EVERY 1 AND 2 CELLS (STANDARD PART OF THE LHC MACHINE)

Figure 4:

SCHEMATIC OF A QRL - MAIN CRYOSTAT INTERCONNECT SHOWING SECTORIZATION HARDWARE (VALVES - PLUGS - BARRIERS)

Figure 5:

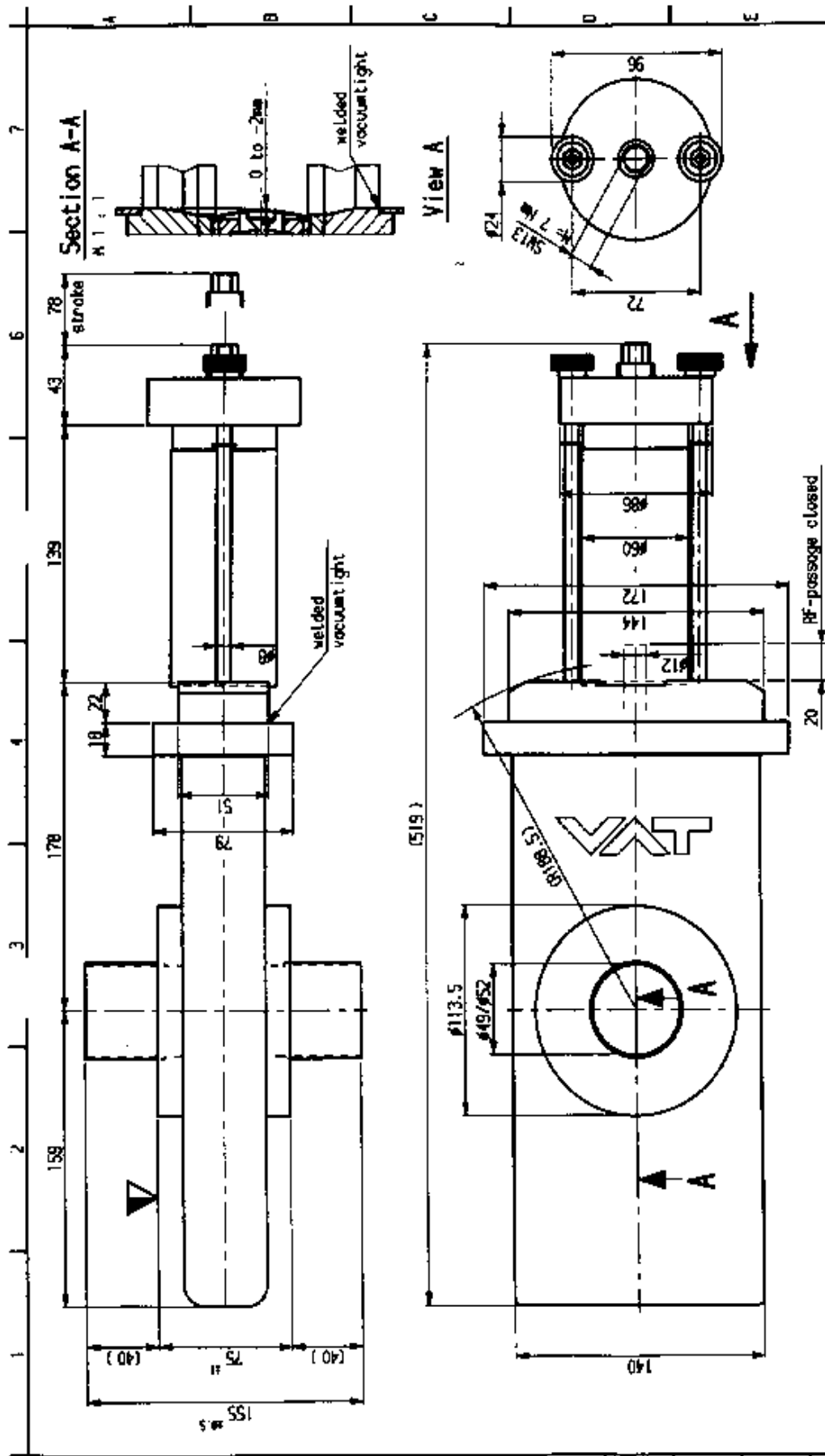

Date: 31-JAN-96
 Zeit: 15:45:10
 Name: GÄßNER

<p>Projection E</p>		<p>Series 47.1</p> <p>Code</p>	
<p>DN 49</p> <p>Flange</p>		<p>RF-All-Metal Gate Valve</p>	
<p>Manuel actuator</p> <p>X = removable actuator</p>		<p>Dimensional Drawing</p> <p>88559</p>	
<p>Oben sitze Besondere d'air comprimé Bruchteil elektrisch Pignage pour direction de fuite Indicateur de position Indicateur de position Hauteur requise pour démontage Commande de sécurité Pour fixation 2008 d'10/0009</p>		<p>WAT Vakuumtechnik AG Carl-Neuberg-Str. 10 42699 Solingen Tel. 0212 701818 Fax 0212 701870 21.01.96 88559</p>	
<p>Verteilstelle Pressluftanschluss Elektr. Anschluss Lecktauchbohrung Mech. Stellungsmontage Logenleiter Sanitätliche Anschluss Arbeitsleistung Für Befestigung Aufhängemöglichkeit</p>		<p>WAT</p>	
<p>Swat side Comp. air connection Electrical connection Leak detection port Mech. pos. indication Position indicator Required for dismantling Emergency actuation For occupation Disassembly group</p>		<p>WAT</p>	
<p>This drawing is the property of WAT. It must not be copied or distributed without the written consent of WAT. © WAT 1996</p>		<p>WAT-CAD</p>	

Figure 6 : Total Down Time of the LHC Machine for Unscheduled Interventions vs. Number of Cryogenic Sectors

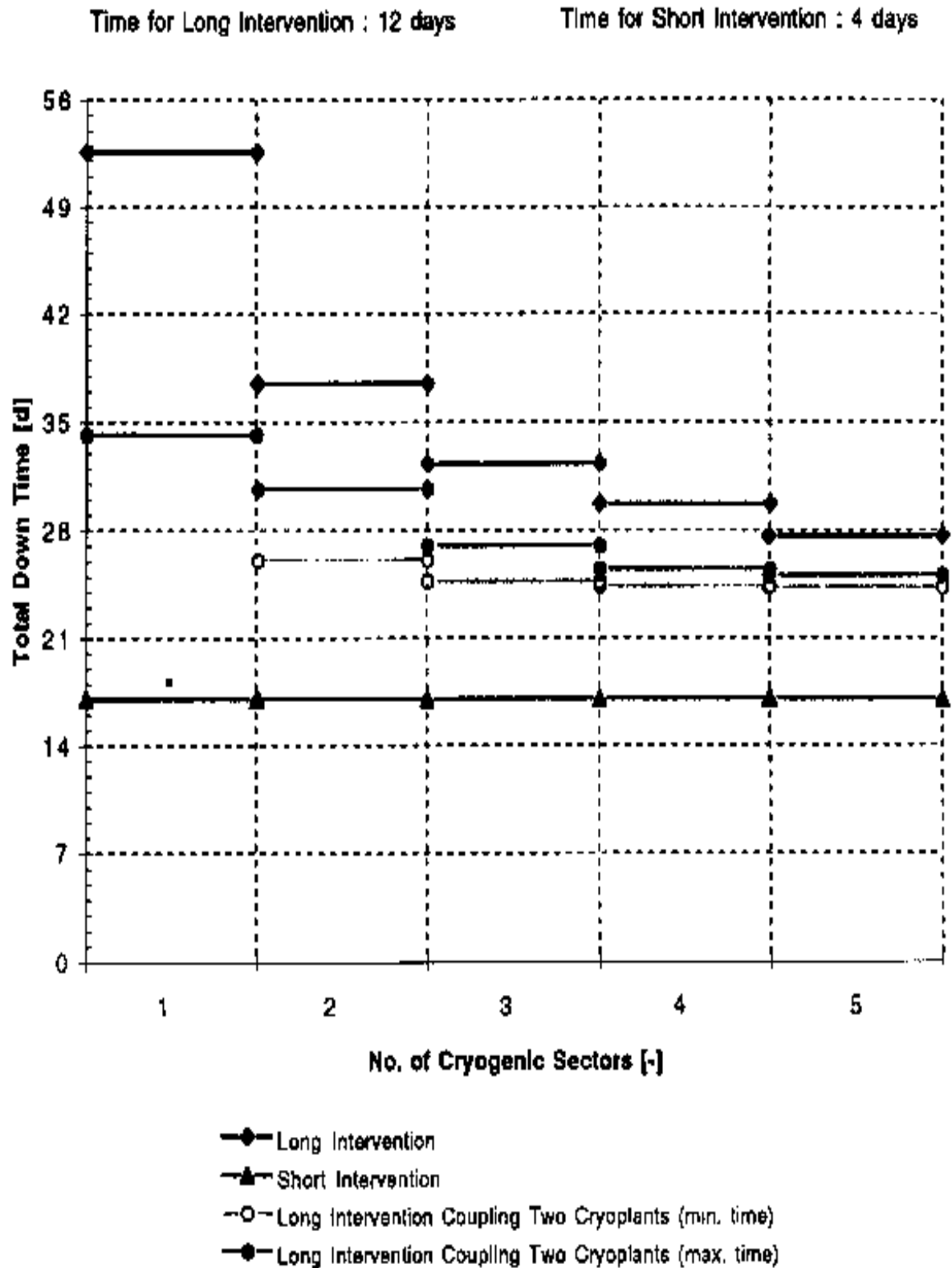

* only possible for interventions on the insulation vacuum and the pressurised HeII enclosure

Figure 7: Total Down Time of the LHC Machine for Unscheduled Interventions vs. Number of Cryogenic Sectors

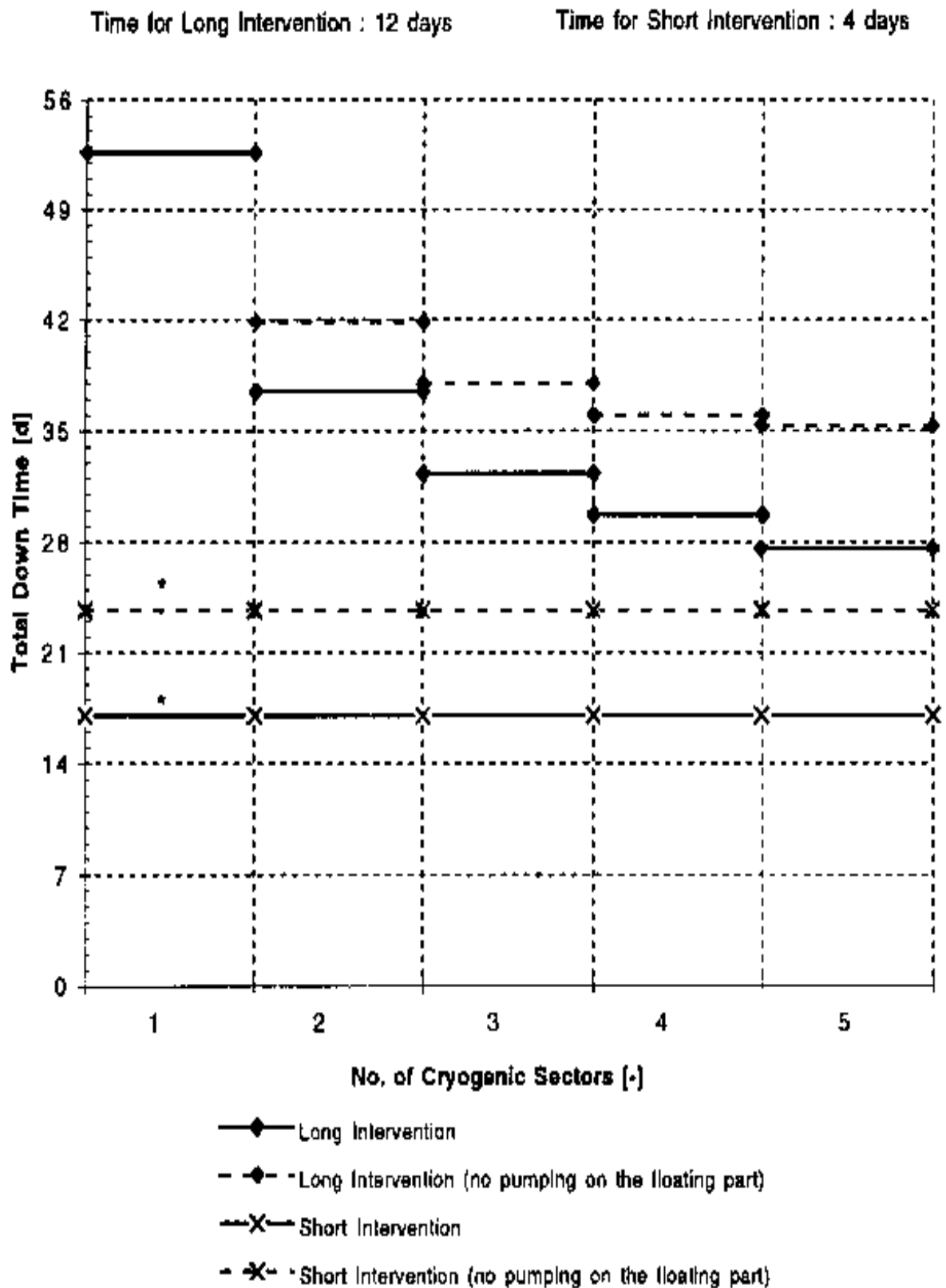

* only possible for interventions on the insulation vacuum and the pressurised HeII enclosure

Figure 8:

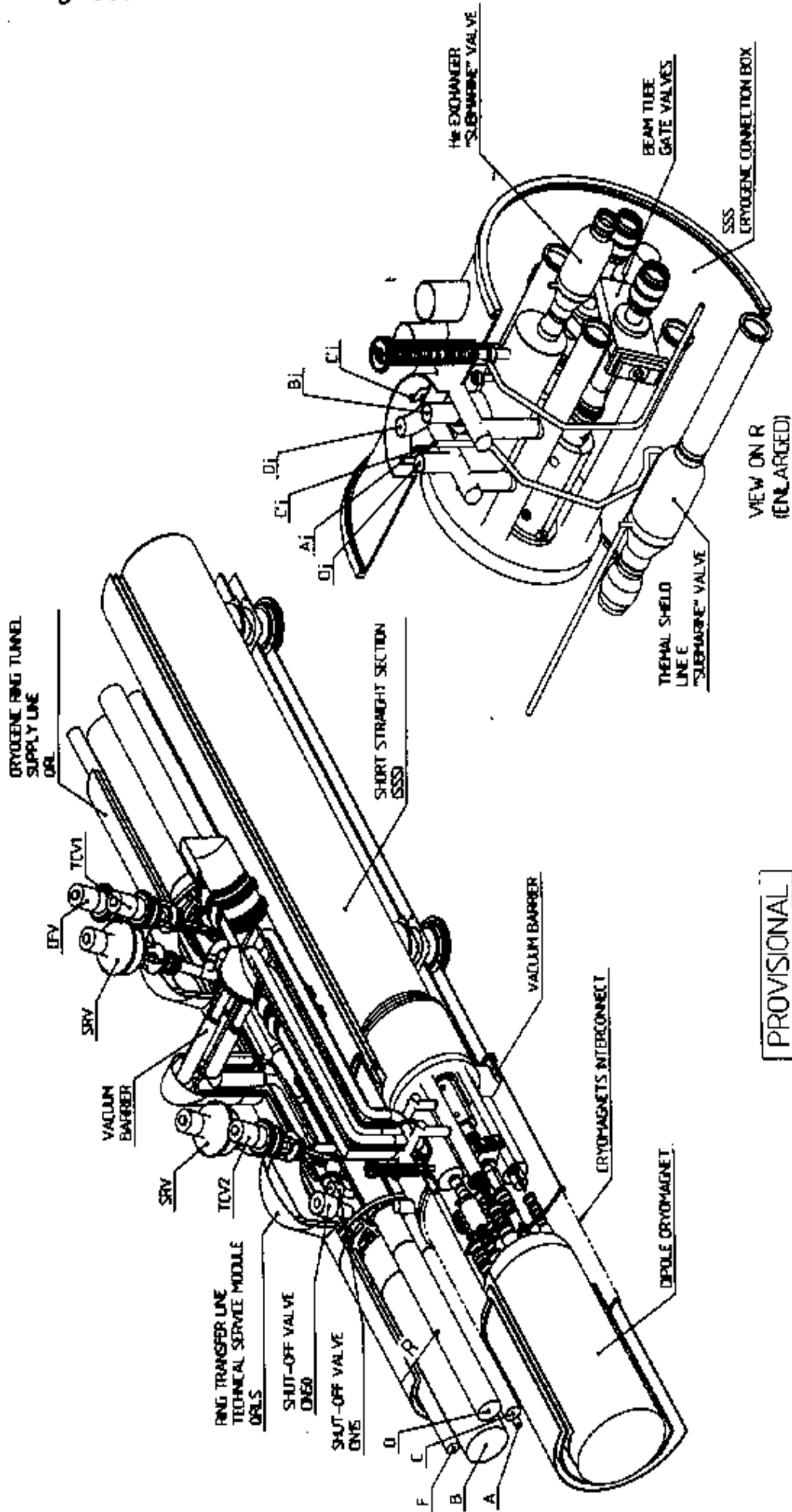

[PROVISIONAL]

SSS - ORLS CONNECTION WITH PROPOSED SUB-SECTORIZATION VALVES

ENCLOSURE 100-100000

ENCLOSURE 100-100000

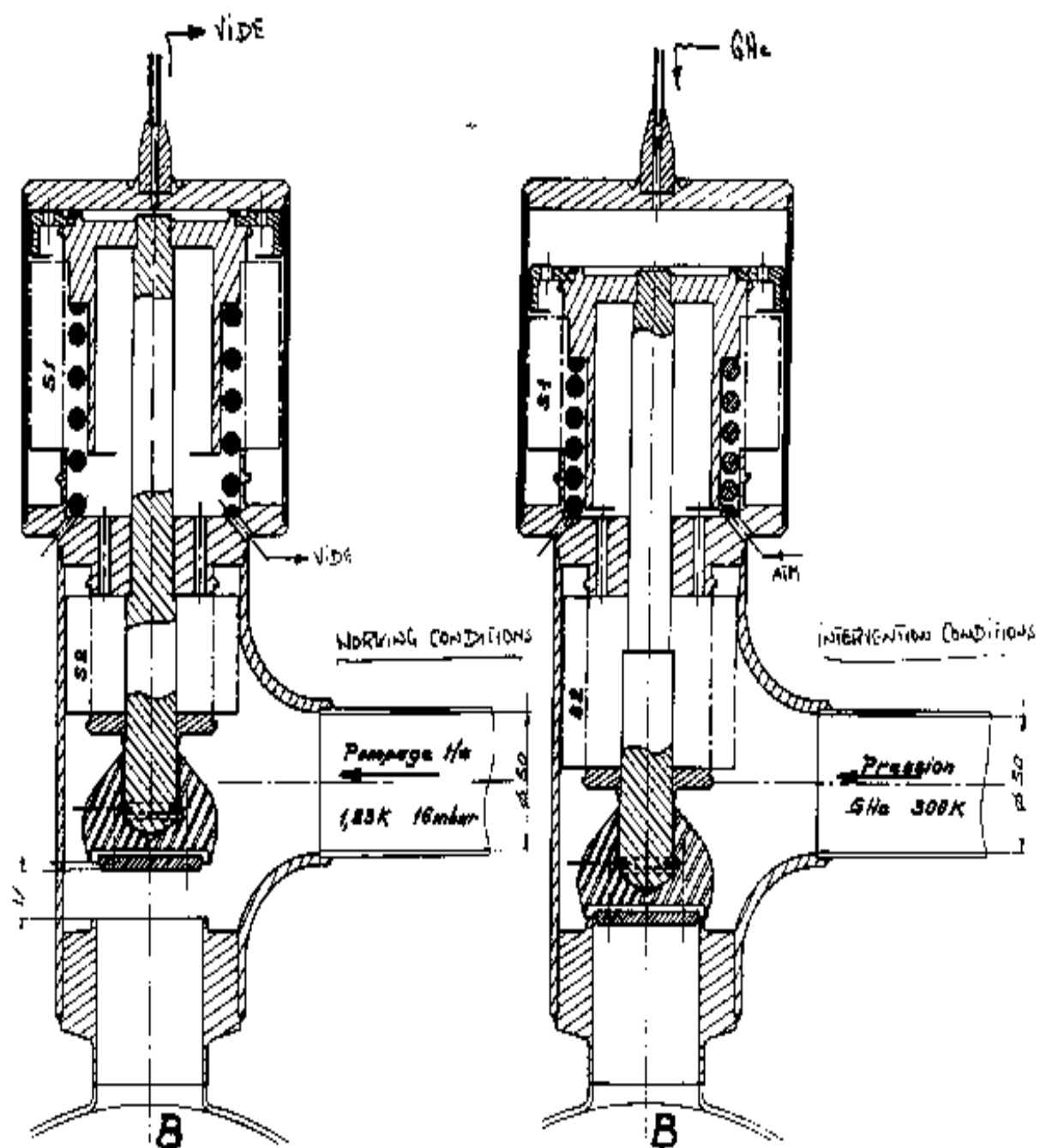

Figure 9: **LHC - QRL**

**Pneumatic shut-off valve
with incorporated safety device**

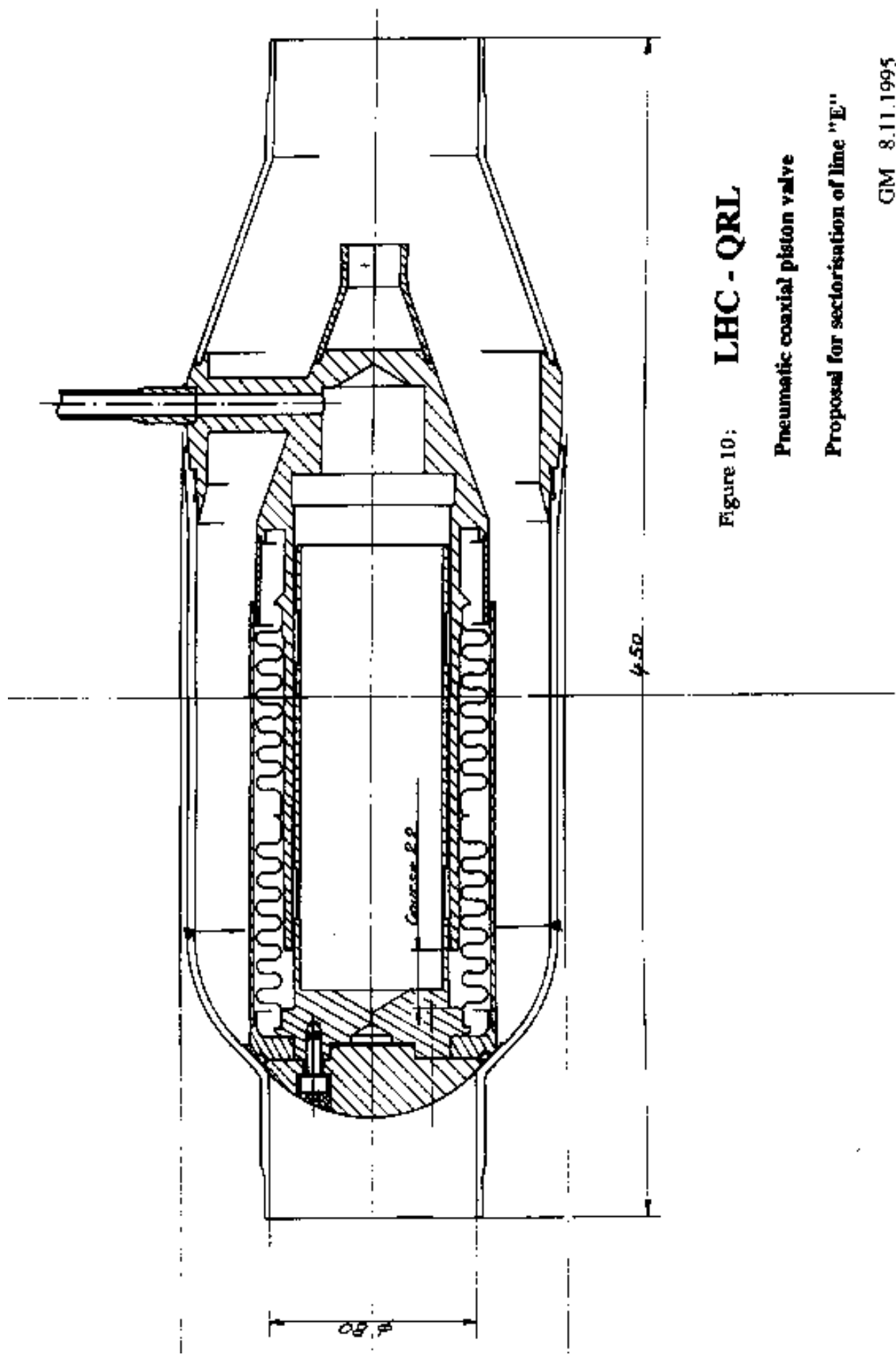

Figure 10: LHC - QRL

Pneumatic coaxial piston valve

Proposal for sectorisation of line "E"

GM 8.11.1995