

REVIEW ARTICLE

Mitochondrial complex I deficiency: from organelle dysfunction to clinical disease

Felix Distelmaier,^{1,2,3} Werner J.H. Koopman,¹ Lambertus P. van den Heuvel,²
Richard J. Rodenburg,² Ertan Mayatepek,³ Peter H.G.M. Willems¹ and Jan A.M. Smeitink²

1 Department of Membrane Biochemistry, Nijmegen Centre for Molecular Life Sciences, Radboud University Nijmegen Medical Centre, Nijmegen, The Netherlands

2 Department of Pediatrics, Nijmegen Center for Mitochondrial Disorders, Radboud University Nijmegen Medical Centre, Nijmegen, The Netherlands

3 Department of General Pediatrics, Heinrich-Heine-University, Düsseldorf, Germany

Correspondence to: Dr F. Distelmaier,
Department of General Pediatrics,
University Children's Hospital,
Heinrich-Heine-University,
Moorenstr. 5, D-40225 Düsseldorf,
Germany
E-mail: felix.distelmaier@med.uni-duesseldorf.de

Mitochondria are essential for cellular bioenergetics by way of energy production in the form of ATP through the process of oxidative phosphorylation. This crucial task is executed by five multi-protein complexes of which mitochondrial NADH:ubiquinone oxidoreductase or complex I is the largest and most complicated one. During recent years, mutations in nuclear genes encoding structural subunits of complex I have been identified as a cause of devastating neurodegenerative disorders with onset in early childhood. Here, we present a comprehensive overview of clinical, biochemical and cell physiological information of 15 children with isolated, nuclear-encoded complex I deficiency, which was generated in a joint effort of clinical and fundamental research. Our findings point to a rather homogeneous clinical picture in these children and drastically illustrate the severity of the disease. In extensive live cell studies with patient-derived skin fibroblasts we uncovered important cell physiological aspects of complex I deficiency, which point to a central regulatory role of cellular reactive oxygen species production and altered mitochondrial membrane potential in the pathogenesis of the disorder. Moreover, we critically discuss possible interconnections between clinical signs and cellular pathology. Finally, our results indicate apparent differences to drug therapy on the cellular level, depending on the severity of the catalytic defect and identify modulators of cellular Ca^{2+} homeostasis as new candidates in the therapy of complex I deficiency.

Keywords: NADH:ubiquinone oxidoreductase deficiency; Leigh disease; ATP production; reactive oxygen species; treatment

Abbreviations: $[\text{ATP}]_M$ peak = bradykinin-induced peak increase in mitochondrial ATP concentration; BN-PAGE = blue-native polyacrylamide gel electrophoresis; Bk = bradykinin; $[\text{Ca}]_C$ peak = bradykinin-induced peak increase in cytosolic free Ca^{2+} concentration; $[\text{Ca}]_M$ peak = bradykinin-induced peak increase in mitochondrial free Ca^{2+} concentration; CM-DCF = 5-[and -6]-chloromethyl-2',7'-dichlorofluorescein; CI = complex I or NADH:ubiquinone oxidoreductase; ER_{Ca} = resting calcium content of the endoplasmic reticulum; ET = hydroethidine; OXPHOS = oxidative phosphorylation; ROS = reactive oxygen species; $t_{1/2}$ = half-time of the decay of the cytosolic free Ca^{2+} concentration following its peak increase in bradykinin-stimulated cells; $\Delta\psi$ = mitochondrial membrane potential

Introduction

Unlike any other structure in mammalian cells, mitochondria are partially autonomous, highly dynamic organelles, which possess their own genome with transcriptional and translational machinery (Duchen, 2004). Together with these unique properties, mitochondria hold a central position in cellular bioenergetics. The most important mitochondrial energy-yielding reaction is performed by the oxidative phosphorylation system (OXPHOS). This system can be resolved into five large multi-subunit complexes (CI–CV) and is embedded in the inner mitochondrial membrane. Thirteen of the ~80 essential OXPHOS subunits are encoded by maternally inherited mitochondrial DNA and the remainder by nuclear DNA. Electron transfers from OXPHOS substrates to molecular oxygen results in the translocation of protons across the inner mitochondrial membrane at CI, CIII and CIV, which creates a substantial electrochemical gradient. This gradient is utilized for ATP synthesis, ion translocation and protein import.

The importance of mitochondria for cell viability is most dramatically highlighted by the diseases, which are caused by its malfunction. OXPHOS disorders range from fatal encephalomyopathies of early childhood (e.g. Leigh disease) to severe diseases of adulthood (e.g. Parkinson's disease, Alzheimer's disease, Type 2 diabetes mellitus) (Lin and Beal, 2006; Zeviani and Carelli, 2007; Civitaresse and Ravussin, 2008). In general, OXPHOS disorders make a contribution of about 1 per 5–10 000 live births in man, which indicates that they can be regarded as one of the most common groups of inborn errors of metabolism (Thorburn, 2004). Among these disorders, isolated CI deficiency is the most frequently encountered defect of the mitochondrial energy metabolism (Smeitink *et al.*, 2001). From a medical perspective, CI malfunction caused by mutations in nuclear genes is critically involved in severe multisystem disorders with onset of symptoms at a young age. The dramatic impact of mutations in these genes on neurodevelopment and patient survival is related to critical alterations in cell metabolism, energy homeostasis and reactive oxygen species (ROS) production (Smeitink *et al.*, 2004). However, the crucial interconnection of these parameters with clinical signs and symptoms is still poorly understood. Based on a joint effort of clinical and cell physiological studies, this review aims to give a combined view on the consequences of nuclear-encoded CI defects in both the affected cell and the diseased child.

Mitochondrial complex I: as good as its building bricks

Mammalian CI (NADH:ubiquinone oxidoreductase; EC 1.6.5.3) is the largest protein-assembly of the respiratory chain and forms the major entry-point of electrons into the OXPHOS system. Structurally, it consists of 45 subunits, 7 encoded by mitochondrial DNA and 38 by nuclear DNA (Carroll *et al.*, 2006). Its catalytic core comprises 14 evolutionary conserved subunits, which, in humans, are encoded by the nuclear *NDUFV1*, *NDUFV2*, *NDUFS1*, *NDUFS2*, *NDUFS3*, *NDUFS7* and *NDUFS8*

genes and the mitochondrial *ND1–ND6* and *ND4L* genes (Brandt, 2006). The complex can be dissociated into a soluble peripheral arm containing the flavoprotein and iron protein subunits, and a hydrophobic arm embedded in the inner mitochondrial membrane. To facilitate the proper buildup and stability of CI protein, several assembly chaperones are required (Vogel *et al.*, 2007).

The main task of CI is to take over electrons from NADH to transfer them to ubiquinone, a lipid-soluble carrier of the inner mitochondrial membrane. The energy that originates from this process is used to move protons across the inner membrane, creating an inside negative membrane potential. Importantly, during this process, premature electron leakage to oxygen may occur, which makes CI a main site of cellular superoxide production (Duchen, 2004).

Obviously, structural integrity of CI is essential to maintain its functionality. Therefore, alterations in one of its 'building bricks' may lead to catalytic problems or instability of the complete assembly. Up to now, disease causing mutations have been described in all 7 mitochondrial DNA-encoded subunits and 12 of the nuclear DNA-encoded subunits (van den Heuvel *et al.*, 1998; Loeffen *et al.*, 1998, 2001; Schuelke *et al.*, 1999; Triepels *et al.*, 1999; Bénit *et al.*, 2001, 2003, 2004; Kirby *et al.*, 2004; Fernandez-Moreira *et al.*, 2007; Berger *et al.*, 2008; Hoefs *et al.*, 2008). Most of these defects are inherited in an autosomal recessive manner; however, X-linked inheritance has also been described (Fernandez-Moreira *et al.*, 2007). Finally, mutations in the CI assembly factors *NDUFAF2*, *NDUFAF1*, *C6orf66*, *C8orf38*, and *C20orf7* have been described (Ogilvie *et al.*, 2005; Dunning *et al.*, 2007; Pagliarini *et al.*, 2008; Saada *et al.*, 2008; Sugiana *et al.*, 2008). The increasing knowledge of CI composition and its regulation illustrates the complexity of this biochemical system. In our research, we mainly investigate the consequences of mutations in nuclear DNA-encoded CI subunits and therefore, will focus on this aspect in this article.

Complex I deficiency: a fragile condition

Mutations in nuclear genes encoding structural subunits of CI have a dramatic effect on neurodevelopment and overall patient survival (Shoubbridge, 2001; Janssen *et al.*, 2006). The majority of children present with Leigh disease, an early-onset, fatal neurodegenerative disorder that is typically characterized by symmetrical lesions of necrosis and capillary proliferation in variable regions of the central nervous system. Clinical signs and symptoms include muscular hypotonia, dystonia, developmental delay, abnormal eye movements, seizures, respiratory irregularities, failure to thrive and lactic acidemia (Loeffen *et al.*, 2000). Additional clinical phenotypes that have been described in the context of nuclear-encoded CI deficiency are the syndromes of fatal infantile lactic acidosis (FILA), neonatal cardiomyopathy with lactic acidosis, leucodystrophy with macrocephaly and hepatopathy with renal tubulopathy (Pitkänen *et al.*, 1996; Loeffen *et al.*, 2000). However, the significance of such classifications might be a matter of debate (see below).

In our effort to gain a better understanding of these devastating diseases, we collected clinical information and investigated tissue specimens of such patients over the last decades. In 15 of these children (four girls and 11 boys), with enzyme deficiency in both muscle tissue and cultured skin fibroblasts, we were able to uncover disease-causing mutations in nuclear genes encoding CI subunits (P14 and 15 see Schuelke *et al.*, 1999; P11 see Triepels *et al.*, 1999; P2, 3 and 4 see Loeffen *et al.*, 2001; P6, 7, 8 and 10 see Budde *et al.*, 2003; P1 see Visch *et al.*, 2004; P9, 12 and 13 see Koopman *et al.*, 2005; P5 see Visch *et al.*, 2005). The detailed overview in Table 1 illustrates the various clinical features that were observed in these children, whereas Table 2 depicts the mutations and crucial parameters of cellular and mitochondrial function. As indicated by the red patterns, certain clinical abnormalities were common in this group and appeared to be important features of nuclear-encoded CI deficiency. These included basal ganglia and/or brainstem lesions, respiratory abnormalities, muscular hypotonia, failure to thrive, seizures and lactic acidemia. Most of these abnormalities were linked to the affection of the nervous system and skeletal muscles, which are tissues with a high demand for OXPHOS-derived energy. In general, children had a normal prenatal development were born at term and did not show obvious organ anomalies or dysmorphic features. The only exception was patient 12, who was born preterm with a low birth weight and who presented with low set ears, single palmar creases and wide sutures. Most children developed symptoms during the first year of life and then suffered from rapid disease deterioration. In all cases the disease was fatal (two children died already in the neonatal period, another six did not reach the age of one and the longest survival was only 60 months).

During recent years, at least 26 additional patients (17 boys, nine girls) with nuclear-encoded CI deficiency have been reported in the literature (Bénit *et al.*, 2001, 2003, 2004; Petruzzella *et al.*, 2001; Kirby *et al.*, 2004; Procaccio *et al.*, 2004; Martín *et al.*, 2005; Laugel *et al.*, 2007; Lebon *et al.*, 2007; Moiera *et al.*, 2007; Hoefs *et al.*, 2008; Anderson *et al.*, 2008). Mutations were established in the *NDUFV1* (four patients), *NDUFV2* (three patients), *NDUFS1* (four patients), *NDUFS3* (one patient), *NDUFS4* (six patients), *NDUFS6* (three patients), *NDUFS7* (one patient), *NDUFS8* (one patient), *NDUFA1* (two patients) and *NDUFA2* (one patient) genes. In general, disease course and clinical symptoms were as severe as those observed in our patients. Twenty-three patients had a disease onset during the first year of life, mostly characterized by psychomotor retardation, failure to thrive, muscular hypotonia, atypical eye movements and seizures. Seventeen patients died before the age of one year. In 20 patients elevated blood lactate levels were reported and almost all patients had rather typical lesions on MRI or CT, located mainly in the basal ganglia and brainstem. Three patients suffered from extensive white matter lesions. Unusual exceptions were a boy with an *NDUFS3* mutation and a girl with a *NDUFS8* mutation who had a late disease onset (9 and 7 years, respectively; Bénit *et al.*, 2004; Procaccio *et al.*, 2004) and who were still alive at the time of the report. In addition, one boy with mutation in the *NDUFA1* gene and one boy with mutation in the *NDUFV1* gene were relatively old at the time they were reported (10 and 7 years, respectively;

Fernandez-Moiera *et al.*, 2007; Laugel *et al.*, 2007). Nevertheless, in a combined view of the information about our patients and the data of those other children reported so far, it appears that, although mitochondrial disorders are generally regarded as very heterogeneous, a more consistent clinical picture is obtained for isolated, nuclear-encoded CI deficiency. This observation appears to be in contrast to CI deficiency caused by mutations in the mitochondrial DNA. These defects may present at any age, ranging from early childhood to late adolescence and there is a broader variability in clinical symptoms and organ affections (for more details see Loeffen *et al.*, 2000; Janssen *et al.*, 2006). This variability is influenced by the balance between wild-type and mutant mitochondrial DNA (heteroplasmy), which may be different between tissues and may change during cell division (mitotic segregation). Importantly, in view of the above findings, it remains questionable whether atypical features like dysmorphia—as observed in our patient 12—in children with established mutations in nuclear CI genes may be indicative of an additional gene defect that has not yet been uncovered. This idea gains importance against the background that patients with CI deficiency frequently come from consanguineous families where unusual genetic constellations may be suspected (seven children in our group including P12).

Apart from the 'normal', non-syndromic appearance of CI deficient patients it also appears to be striking that affected children mostly have an uneventful pregnancy and normal birth parameters. This aspect is not only highlighted by our patient group but also by the other children described in the literature, where 19 patients had normal pregnancy and birth parameters and only one girl was reported to be small for gestational age (Bénit *et al.*, 2003). Apparently, the organism is especially well protected and supplied during the prenatal period (which might also explain the usually normal morpho- and organogenesis). This idea is supported by studies, describing a marked increase of respiratory chain activities and mitochondria content in postnatal compared to prenatal tissues, which indicates a higher demand for OXPHOS derived energy after birth (Smeitink *et al.*, 1992; Minai *et al.*, 2008). As soon as a CI deficient child is challenged by infections or a period of fasting the situation might rapidly deteriorate. In this context, it is also important to note that in most children, reported here, the first symptoms and further episodes of deterioration were triggered by a respiratory or gastrointestinal infection.

For clinical identification and classification of CI deficient children, it appears desirable to establish genotype–phenotype correlations and to describe specific constellations of signs and symptoms as syndromes. However, although some mutations have a great share in certain clinical features, obvious mutation-related phenotypes are not apparent. For example, features like cardiomyopathy have been reported to be rather characteristic in the context of *NDUFS2* mutations (Loeffen *et al.*, 2001); however, we also observed this abnormality in children with mutations in *NDUFS4* and *NDUFS8* (Table 1). Moreover, hypertrophic cardiomyopathy has been reported in patients with *NDUFV2* and *NDUFA2* mutations (Bénit *et al.*, 2001; Hoefs *et al.*, 2008). Another example is patients with extensive leucodystrophy instead of delimited lesions in the basal ganglia or brainstem. This feature

Table 1 Clinical symptoms and organ lesions observed in complex I deficient children

Patient #		1	2	3	4	5	6	7	8	9	10	11	12	13	14*	15*
Sex		F	M	M	M	F	M	M	F	M	F	M	M	M	M	M
AO (months)		8	10	0.03	6	3	8	2	4	3.5	0.25	11	0.03	0.03	7	5
AD (months)		27	36	0.13	24	6	16	4.5	8	4.5	3	60	0.03	11	17	14
Pregnancy and birth	Gestational a.	T			T	T	T	T	T		T		P	T	T	
	Birth weight	N			N	N	N	N	N				↓		N	
	Birth length	N			N	N	N	N	N						N	
	APGAR	N			N	N	N	N	N		N		X	N	N	
Central nervous system	Hemispherical les.	X	-		-	-	-	-	-	-	-	-	X	X		
	Basal ganglia les.	-	X		X	X	X	X	X	X	X	X		X		
	Brainstem les.	-	-		-	X	-	X	X	X	X	-	X		X	
	Seizures	X	-		-	X	X	X	X	X	X	-	X	X	X	X
	Spasticity	X	-		X											
	Dystonia	X			X											
	Resp. abnorm.	-	-	X	X	X	X	X	X	X		X	X	X	X	X
	Ep. vomiting	X	X		X	-	X	-	-			-				
Skeletal muscle and heart	Hypotonia	X	X		X	X	X	X	X	X	X	X	X	X	X	X
	Hypertonia	X	-		X	-	-	-	-	-	-	-	-	-	-	-
	RRF	-	-		-	-	-	X	-	-	-	-	-	-	-	-
	Hypertroph. C.	-	-	X	X			X	-	-	-	-	-	X	-	-
	Dilated C.	-	-		-	-	-	-	-	X	-	-	X	-	-	-
Visual / auditory system	ODA	-	-		X	X		-	-	-	-	-	-	-	-	-
	Amaurosis	-	-		X	X		X	X	X	X	-	-	X	-	-
	Nystagmus	-	X		X	X		-	-	-	-	-	-	-	-	-
	Deafness	-	-		-	-		X								
Other features	FTT	X	-	X	X	X	X	X	X	X	X	X	X	X	X	X
	Dysmorphism	-	-		-	-	-	-	-	-	-	-	X	-	-	-
	Microcephaly	-	-		-	-	-	-	-	-	X	-	-	-	-	-
	Macrocephaly	-	-		-	-	-	-	-	-	-	-	-	-	-	-
Laboratory parameters	Blood lactate	↑	↑↑	↑↑↑	↑↑↑	↑	NE	NE	↑	↑	↑↑	NE	↑↑↑	↑	↑	↑
	CSF lactate	↑	↑		↑↑↑	↑	NE	↑	↑		↑↑↑	NE		↑↑↑	↑	↑
	LP ratio	NE		E					E	NE	E	NE		E		
	Alanine	NE						E	NE		E				E	E
	OAB					NE	NE					NE				
	OAU	E	E		E		NE	NE	E	E	E	NE			NE	E
	AAB	E				NE	NE				NE	NE				
	AAU	E				NE	NE	NE			E	E			E	E

Red boxes = abnormal; green boxes = normal; grey boxes = information not available; X = feature present; - = feature absent; M = male; F = female; AO = age of onset; AD = age of death; T = term; P = preterm; ↓ = small for gestational age; *These children were brothers. ep. = episodic; C. = cardiomyopathy; resp. = respiratory; a. = age; les. = lesions. Laboratory parameters: blood lactate levels in mmol/l: N = normal (1.06–1.89); ↑ = mildly elevated (1.9–4.0); ↑↑ = moderately elevated (4.1–7.0); ↑↑↑ = severely elevated (>7.0); cerebrospinal fluid (CSF) lactate in mmol/l: N = normal (1.2–2.1); ↑ = mildly elevated (2.1–4.0); ↑↑ = moderately elevated (4.1–7.0); ↑↑↑ = severely elevated (>7.0); lactate/pyruvate (LP) ratio: N = normal (11.5–16.5); ↑ = elevated; alanine in μmol/l: NE = not elevated (≤ 450); E = elevated (>450); OAB = organic acids in blood; OAU = organic acids in urine; AAB = amino acids in blood; AAU = amino acids in urine; E = elevated/abnormal pattern; NE = not elevated/normal pattern; RRF = ragged red fibres; FTT = failure to thrive; ODA = optic disc atrophy.

Table 2 Cell-physiological features of complex I deficient patient fibroblasts

Cell line	Mutation	CI	MMP	NAD(P)H	ER _{Ca}	[Ca] _C peak	[Ca] _M peak	[ATP] _M peak	t _{1/2}	Et	CM-DCF	F	Nc	F/Nc
CT1 (#5120)	N.a.	113	100	100	100	100	100	100	100	100	100	100	100	100
CT2 (#5119)	N.a.	105	99	86	105	104	96	101	95	102	100	99	97	102
CT3 (#5118)	N.a.	103	99	109	105	100	103	110	95	98	125	105	95	111
CT4 (#4996)	N.a.	n.d.	99	n.d.	n.d.	n.d.	n.d.	n.d.	n.d.	100	n.d.	n.d.	n.d.	n.d.
CT5 (MW26)	N.a.	152	n.d.	n.d.	n.d.	n.d.	n.d.	97	n.d.	100	n.d.	n.d.	n.d.	n.d.
CT6 (MW28)	N.a.	97	n.d.	n.d.	n.d.	n.d.	n.d.	98	n.d.	n.d.	n.d.	95	105	91
CT7 (MW33)	N.a.	220	n.d.	n.d.	n.d.	n.d.	n.d.	101	n.d.	99	n.d.	n.d.	n.d.	n.d.
P1 (#6173)	NDUFS1-R557X/D618N	31	92	142	82	91	86	77	136	176	171	76	116	66
P2 (#4605)	NDUFS2-S413P	40	n.d.	n.d.	n.d.	93	n.d.	72	130	218	n.d.	84	149	56
P3 (#5067)	NDUFS2-P229Q	36	93	191	94	101	87	78	142	264	351	85	137	62
P4 (#5170)	NDUFS2-R228Q	39	98	140	95	97	95	102	102	205	169	65	95	68
P5 (#7276)	NDUFS2-D445N	26	n.d.	n.d.	82	91	87	60	146	191	244	68	145	47
P6 (#4608)	NDUFS4-K158fs	75	87	130	96	108	97	97	110	195	289	123	103	119
P7 (#4827)	NDUFS4-R106X	58	n.d.	n.d.	n.d.	82	n.d.	33	169	196	n.d.	96	177	54
P8 (#5260)	NDUFS4-R106X	36	93	132	77	84	79	48	160	174	187	104	146	71
P9 (#5737)	NDUFS4-VPEEKH167/VEKSIstop	53	95	127	87	93	96	86	126	131	202	91	88	103
P10 (#5077)	NDUFS4-W97X	59	n.d.	n.d.	n.d.	n.d.	n.d.	n.d.	n.d.	142	n.d.	98	91	108
P11 (#5175)	NDUFS7-V122M	68	90	112	73	80	76	57	164	151	212	117	98	119
P12 (#6603)	NDUFS8-R94C	18	88	170	85	91	89	74	134	222	275	120	167	71
P13 (#5199)	NDUFS8-P79L/R102H	69	n.d.	n.d.	n.d.	n.d.	n.d.	n.d.	n.d.	n.d.	n.d.	99	112	88
P14 (#5866)	NDUFV1-R59X/T423M	64	94	142	87	90	86	67	140	110	135	114	98	116
P15 (#5171)	NDUFV1-R59X/T423M	73	91	130	96	96	99	93	112	186	242	133	107	125

Parameters measured in control (CT) and patient (P) cell lines; subunit and mutation at protein level; CI = complex I activity (% control); MMP = mitochondrial membrane potential; NAD(P)H autofluorescence; ER_{Ca} = resting calcium content of the endoplasmic reticulum; [Ca]_C peak = bradykinin (Bk)-induced peak increase in cytosolic free Ca²⁺ concentration; [Ca]_M peak = Bk-induced peak increase in mitochondrial free Ca²⁺ concentration; [ATP]_M peak = Bk-induced peak increase in mitochondrial ATP concentration; t_{1/2} = half-time of the decay of the cytosolic free Ca²⁺ concentration following its peak increase in Bk-stimulated cells; Et = rate of ethidium formation as a measure of superoxide levels; CM-DCF = rate of 5-[and -6]-chloromethyl-2',7'-dichlorofluorescein formation as a measure of superoxide-derived ROS levels; Nc = number of mitochondria; F/Nc = mitochondrial 'complexity'; F = formfactor as a measure of mitochondrial morphology. Statistics: significant differences with CT1 (*P* < 0.05) are indicated by red boxes; NA = not appropriate; ND = not determined; NDUF = NADH Dehydrogenase Ubiquinone Flavoprotein.

has been described in patients with *NDUFV1* mutations (Schuelke *et al.*, 1999) but has also been observed in children with *NDUFS1* defects (Bénil *et al.*, 2001 and our P1). Therefore, we currently do not support the idea that certain clinical features can be clearly linked to defects in specific CI subunits.

In view of the summarized findings, we regard it as very difficult and sometimes even arbitrary to establish clinical phenotypes or syndromes for nuclear-encoded CI deficiency other than Leigh or Leigh-like disease. Based on the nuclear origin of the defect, every organ system will be affected and may, therefore, display abnormalities to a variable extent, which is most likely determined by its specific demand for OXPHOS-derived energy and a bioenergetic threshold, which depends on the residual, tissue-specific CI activity and also on the individual genetic background (Rossignol *et al.*, 2003). The tissue variability of CI activity was clearly illustrated by our patient 13 with a mutation in the *NDUFS8* subunit. In this case, CI activity was 39% in muscle tissue and 69% in fibroblasts, whereas the activity was completely absent in heart muscle tissue. In addition to the tissue variability, organ abnormalities

and development of symptoms might depend on the clinical course and progression of the disease (e.g. subtle/slowly progressing symptoms may be overshadowed by a very rapid and severe clinical course).

Our difficulties in understanding the pathophysiology of CI deficiency is also reflected by current treatment options, which so far are purely empirical and mainly unsatisfactory. Treatment strategies in our group of CI deficient children were highly variable and sometimes inconsistent. Drugs administered included coenzyme Q, riboflavin, vitamin B1, B12, C, E, K, L-carnitine, dichloroacetate and ketogenic diet. A verified therapeutic success was not achieved in any of the children. These observations are clearly pointing to the necessity of organized clinical trials. However, in view of the rarity of the disease and the time that is usually needed until a diagnosis is established and a gene defect is found, undertakings like this are difficult to accomplish. In addition, rethinking and re-evaluation of our treatment concepts of CI deficiency are necessary. This also requires a better understanding of the cell physiological alterations which are caused by the defects.

On the (sub)cellular level

Clinical symptoms observed in patients should be traceable back to impaired cell metabolism caused by failure of mitochondrial energy-yielding reactions. OXPHOS-dependent cell populations that are post-mitotic are especially vulnerable to CI defects as exemplified by brain, nerve and muscle tissue (Smeitink *et al.*, 2001). However, biopsy material from these tissues is rarely available for research purposes. This especially holds true for nuclear-encoded CI deficiency since children with this disorder usually die at an early age (Table 1) and muscle biopsy material is barely sufficient for routine diagnostics. For these reasons, we use primary skin fibroblasts from the above mentioned children.

Using blue-native polyacrylamide gel electrophoresis (BN-PAGE), we showed that fully assembled CI, as detected with an antibody against the NDUFA9 subunit (Verkaart *et al.*, 2007a; Koopman *et al.*, 2008), and its in-gel activity, as determined by the reduction of nitro-blue tetrazolium in the presence of NADH (Koopman *et al.*, 2008), were significantly decreased (patients labelled P1, P3, P4, P11, P12, P14 and P15 in this review) or even absent (patients labelled P6, P7, P8, P9 and P10 in this review) in mitochondria-enriched fractions from patient fibroblasts. For the first group of patients, a linear correlation was observed between the spectrophotometrically measured CI activity (Table 2) and the in-gel CI activity ($R=0.94$; $P=0.002$). For the second group of patients, all carrying a mutation in the *NDUFS4* gene, only an inactive subcomplex was found after blue-native-PAGE (Verkaart *et al.*, 2007a). In contrast to the absence of any in-gel activity, an obvious albeit significantly reduced, CI activity was measured in the spectrophotometric assay (Table 2; P6–P10). These results may point to a critical role of the *NDUFS4* subunit in maintenance of the functional integrity of the complex, which, in case of a mutation in this subunit, might be disturbed during the BN-PAGE procedure. They indicate that, apart from a catalytic defect and an assembly problem, the stability of CI may also be affected by mutations in its subunits.

Interestingly, according to the current CI assembly model (Vogel *et al.*, 2007; Dieteren *et al.*, 2008; Remacle *et al.*, 2008; Lazarou *et al.*, 2009), biogenesis of the complex starts with the formation of the initial subcomplex-1 of unknown composition. Addition of *NDUFS2* (mutated in P2, P3, P4 and P6), *NDUFS3*, *NDUFS7* (P11) and *NDUFS8* (P12 and P13) leads to formation of subcomplex-2 and subsequent addition of other subunits to the formation of subcomplexes-3 to -6. Finally, addition of *NDUFV1* (P14 and P15), *NDUFV2*, *NDUFS1* (P1) and *NDUFS4* (P6–P10) to subcomplex-6 leads to formation of fully assembled and active holo-CI. Using BN-PAGE of patient fibroblasts, we observed that subunits that were incorporated during a late stage in CI assembly either displayed: (i) a reduced amount of holo-CI and a subcomplex of lower molecular weight (*NDUFS1* and *NDUFV1*); or (ii) only a subcomplex (*NDUFS4*). In contrast, subunits incorporated at an early stage in CI assembly (*NDUFS2*, *NDUFS7* and *NDUFS8*) had a lower amount of holo-CI and no subcomplex. The functional relevance of these findings needs to be investigated in more detail and may help to identify gene defects in affected patients.

In our live cell assays with cultured skin fibroblasts we investigated a number of mitochondrial key parameters that are thought to be affected by CI malfunction (Table 2). One of these parameters is cellular reactive oxygen species production, which has been implicated in the pathology of CI deficiency, based on the fact that the respiratory chain is a major source of oxygen radicals (Luo *et al.*, 1997; Duchen, 2004; Balaban, 2005). As depicted in Table 2, our studies clearly demonstrated that reactive oxygen species levels were elevated in all but one of the patient cell lines, indicated by both the oxidation of hydroethidine (Et, indicating superoxide; Verkaart *et al.*, 2007a) and CM-H₂DCF (indicating superoxide-derived ROS; Verkaart *et al.*, 2007b). Importantly, linear regression analysis revealed that cellular reactive oxygen species production was inversely correlated with the spectrophotometrically determined CI activity for a large cohort of patient cell lines (e.g. the less CI activity the more reactive oxygen species production). Of note, reactive oxygen species levels in patient fibroblasts were also tightly related to cellular NAD(P)H levels, which is indicative of substrate accumulation due to impaired CI function (Verkaart *et al.*, 2007b).

Based on the idea that cellular reactive oxygen species levels and reactive oxygen species-related damage have important influence on mitochondrial morphology (Koopman *et al.*, 2005, 2007; Yoon *et al.*, 2006; Yu *et al.*, 2006), we measured these parameters in the patient fibroblast lines. Strikingly, we found two distinct subgroups of patient cell lines regarding mitochondrial structure: (i) a group with normal or even more elongated mitochondria compared to healthy controls; and (ii) a group with a fragmented mitochondrial morphology (Koopman *et al.*, 2007). When correlating these morphological parameters with the values obtained for cellular reactive oxygen species, we were able to find these subgroups. Thus, patient cell lines with a very low CI activity had high reactive oxygen species levels and a fragmented mitochondrial morphology, whereas, on the other hand, patient cell lines with a rather 'mild' deficiency had lower levels of excessive reactive oxygen species and a normal mitochondrial morphology. We hypothesize that, depending on the level of cellular reactive oxygen species, patient cells with a rather elongated and interconnected mitochondrial network are able to partially compensate/counteract reactive oxygen species, whereas cell lines with a fragmented morphology have possibly surpassed a certain threshold of oxidative stress and are less able to compensate for this problem.

Since oxidative stress may lead to protein damage and alterations in membrane integrity it might also impair the proper maintenance of the mitochondrial membrane potential ($\Delta\psi$), which is created by the OXPHOS complexes I, III, and IV (Dröge, 2002). To access this parameter, we developed a sensitive method to measure $\Delta\psi$ in living cells (Komen *et al.*, 2007; Distelmaier *et al.*, 2008). As indicated in Table 2, almost all patient cell lines had a significantly depolarized $\Delta\psi$ compared to healthy fibroblasts. The observed changes appeared to be small but it is crucial to note that even small alterations of this parameter may have drastic effects on ATP production and protein transport across mitochondrial membranes (Nicholls *et al.*, 2004). Importantly, we recently demonstrated that $\Delta\psi$ can be normalized by baculoviral introduction of the wild-type protein in skin fibroblasts of a patient with a mutation in the *NDUFA2* gene of CI, indicating that

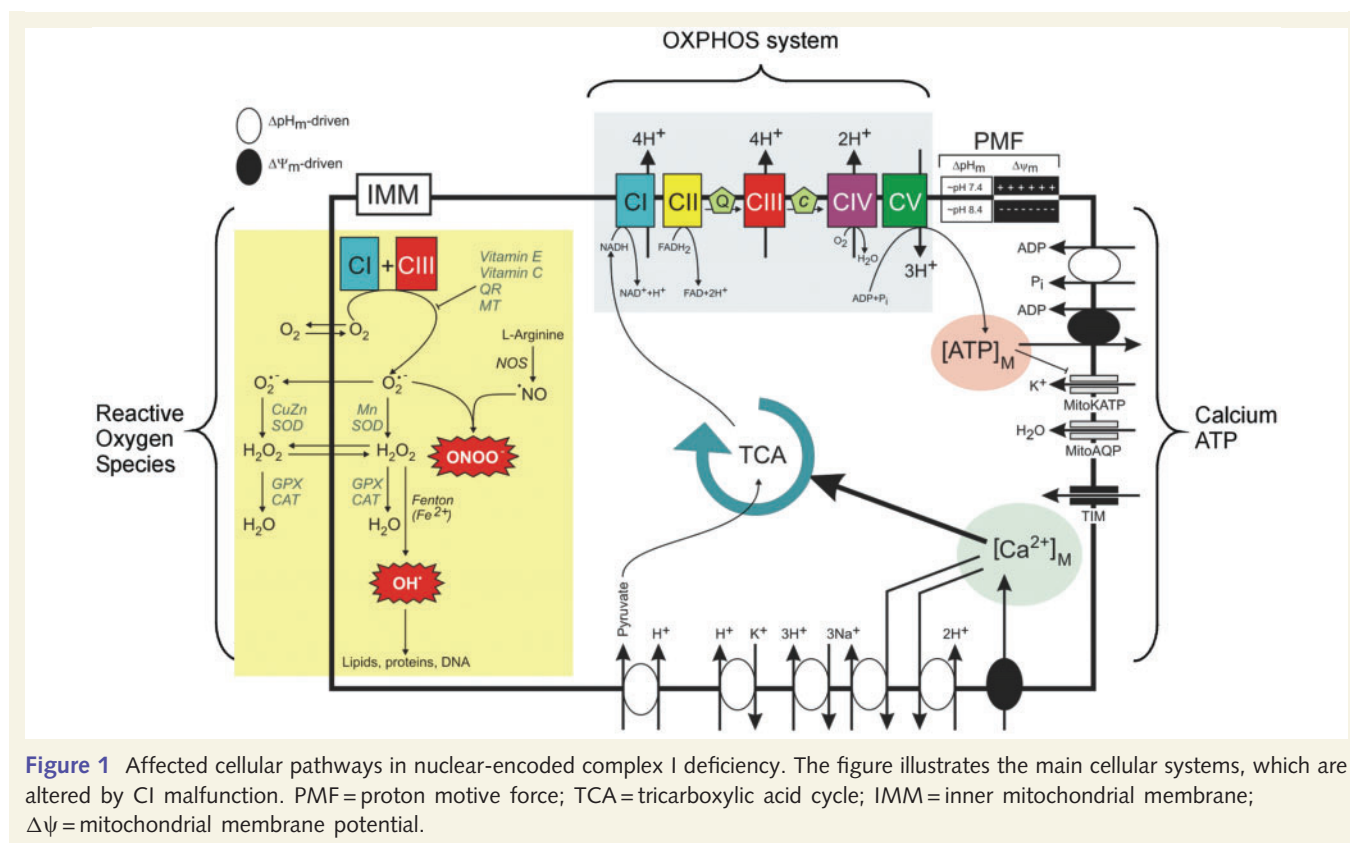

the observed depolarization of $\Delta\psi$ was indeed caused by CI malfunction (Hoefs *et al.*, 2008). In view of cellular reactive oxygen species production, we established a linear correlation between the decrease in $\Delta\psi$ and the increase in superoxide-derived reactive oxygen species levels ($R = -0.84$; $P < 0.001$) (Distelmaier *et al.*, 2009).

Based on the idea that an increase in cellular reactive oxygen species levels caused by CI malfunction, leads to altered mitochondrial structure and mitochondrial depolarization, we studied the effects on mitochondrial ATP production. The oxidative generation of ATP is thought to constitute a key parameter in the pathology of CI deficiency; however, it is difficult to access. We investigated mitochondrial ATP production in living cells using a mitochondrial-targeted luciferase. Our experiments revealed that the rate of mitochondrial ATP production ($[ATP]_M$ peak) after maximal stimulation with bradykinin (Bk), a hormone that increases this parameter in a Ca^{2+} -dependent manner by promoting the transfer of Ca^{2+} from intracellular stores through the cytosol into the mitochondrial matrix, was severely impaired in the majority of patient cell lines (Visch *et al.*, 2006a). Again, linear correlation analysis revealed a close relationship between this parameter and cellular reactive oxygen species as well as $\Delta\psi$.

Finally, cellular ATP supply is crucial for the fuelling of various cellular processes, in particular, the ATPases on the membranes of intracellular Ca^{2+} stores are dependent on mitochondrial ATP supply (Landolfi *et al.*, 1998). Therefore, we investigated cellular Ca^{2+} homeostasis by measuring the cytosolic free Ca^{2+} concentration ($[Ca^{2+}]_C$) and the Ca^{2+} content of the endoplasmic reticulum

(ER_{Ca}) under resting and Bk-stimulated conditions. Moreover, we assayed mitochondrial Ca^{2+} uptake ($[Ca]_M$ peak) with a mitochondrial-targeted variant of the photoprotein aequorin and photomultiplier tube detection. Using these techniques, several important observations were made. Firstly, differences between patient cell lines and healthy controls were mostly visible under stimulated conditions, whereas several parameters were unaltered under resting conditions (Visch *et al.*, 2004, 2006a,b; Willems *et al.*, 2008). Interestingly, the main exception was the resting endoplasmic reticulum Ca^{2+} content, which was reduced in the patient cell lines that showed a decrease in Bk-stimulated mitochondrial ATP production (Visch *et al.*, 2006a). In agreement with this reduction in resting endoplasmic reticulum Ca^{2+} content, we observed smaller increases in cytosolic ($[Ca]_C$ peak) and, as a consequence, in mitochondrial Ca^{2+} ($[Ca]_M$ peak) concentration after Bk stimulation. The latter result explains the decrease in Bk-stimulated mitochondrial ATP production in these patient cells (see above). Most importantly, the rate of Ca^{2+} removal from the cytosol following the Bk-induced $[Ca]_C$ peak was considerably lower in these cells, indicating that mitochondrial ATP supply to nearby Ca^{2+} pumps of endoplasmic reticulum and plasma membrane was seriously hampered (Visch *et al.*, 2006b). Based on these findings, the idea emerged that impaired ATP production, via OXPHOS, leads to a reduced fuelling of the ATPases of the intracellular Ca^{2+} stores which disturbs Ca^{2+} homeostasis. Importantly, during cell activation, mitochondrial Ca^{2+} uptake is a crucial stimulus for ATP production via OXPHOS, which again has an impact on cellular energy supply in CI deficiency

(details are reviewed in Willems *et al.*, 2008). An overview of cellular systems involved in CI deficiency is depicted in Fig. 1.

Taken together, we are beginning to unravel the complex (sub)-cellular alterations which are caused by CI deficiency. Although the role of oxidative stress in mitochondrial diseases is still a matter of debate we support the idea that altered reactive oxygen species levels have a central regulatory role in the pathology of CI deficiency. Nevertheless, disentangling cause and effect of altered cellular parameters in CI deficiency remains a difficult task and certainly requires more research. Importantly, our findings underline that although skin fibroblasts are not among the most vulnerable tissues in CI deficient patients, they are certainly affected by the defect, which makes them an important cellular system to study the cell physiological consequences of the disease. Finally, although it has been suggested that mutations in certain subunits might cause distinctly different cellular phenotypes (Iuso *et al.*, 2006), our overview does not support this idea. Again, the tissue specific differences in CI activity and the individual genetic background might be more important in this context.

From cellular to clinical phenotype?

In view of the above findings we asked whether the observed clinical features corresponded to certain cellular abnormalities and vice versa. However, as it appeared to be true for the genotype–phenotype correlations, we generally did not find back specific patient subgroups with certain cellular abnormalities that were reflected by specific clinical features. In general, it is an obvious difficulty to link data from a cell culture system, which is separated from its original organic context and which is maintained under artificial conditions such as, for example, a higher oxygen tension, to biochemical processes in a living organism as a whole. Moreover, in our studies we focused on skin fibroblasts and, as mentioned earlier, there is a broad range of tissues which may all react differently to the CI defect. These difficulties were highlighted by the cell lines derived from the two brothers with identical mutations in the *NDUFV1* gene (P14 and P15). These children had a comparable clinical course but the fibroblast lines showed striking differences for several cell physiological parameters (Table 2). In view of these observations, secondary factors and/or genetic modifiers on the cellular level must be considered. Moreover, tissue specific effects of the mutation may be responsible for these differences and newly established animal models hold great promise to increase our knowledge of CI deficiency (Kruse *et al.*, 2008). Nevertheless, cellular parameters might still indicate specifically severe problems as exemplified by the two children with neonatal lactic acidosis who died during their first day of life (P3 and P12). The fibroblast lines derived from these children showed the highest cellular reactive oxygen species levels and were also among the most severely affected cell lines in several other assays (Table 2). Despite the above mentioned problems and limitations of our research, we are convinced that studying patient-derived cell lines is crucial to understand the effects of a mutation in its specific and unique genetic

background. As discussed further below, this may gain special importance in view of the development of therapeutic strategies for CI deficiency.

Perspectives

A better understanding of clinical and cell physiological alterations—caused by CI deficiency—is crucial to develop therapeutic strategies. As mentioned above, treatment regimens of CI deficient children are purely empirical and most lack success. Although important links between clinical features and cellular problems are still missing, our strategies with combined clinical, genetic and cell physiological investigations provide a useful approach to study critical aspects of CI deficiency. In recent cell studies, we have investigated the drug CGP-37157, which specifically influences cellular Ca^{2+} homeostasis. This substance, which is a potent blocker of mitochondrial Ca^{2+} export, thereby promoting Ca^{2+} -stimulated mitochondrial ATP production, evoked a complete restoration of cellular energy production in patient-derived skin fibroblasts (Visch *et al.*, 2004). These promising results may open new perspectives for treatment approaches that could complement current strategies. Moreover, the findings highlight additional aspects of cellular physiology, such as Ca^{2+} handling, which should be considered in theoretical treatment concepts of CI deficiency. Importantly, our live cell studies also provided crucial lines of evidence that not every patient cell line reacts in a similar way to a specific drug treatment (Koopman *et al.*, 2008). Using the water-soluble vitamin E analogue Trolox, we observed that pretreatment with this established antioxidant increased the amount of fully assembled CI in both healthy control cells and several patient cell lines (P1, P3, P4, P11, P12, P14 and P15 in this review). However, only in cells of P11 and, to a lesser extent, P14 and P15, was this increase in fully assembled complex paralleled by a marked increase in in-gel enzymatic activity, indicating that these patients mainly had a CI expression as opposed to an intrinsic catalytic activity defect. On the other hand, in cells of P1, P4 and P12, only a minor increase in in-gel activity was observed, suggesting that these patients had both a CI expression and intrinsic catalytic activity problem. Preliminary experiments revealed that in the group of patients with a mutation in the *NDUFS4* gene (P6–P10), chronic Trolox treatment increased the amount of inactive subcomplex without causing the appearance of any complex with in-gel activity. When extrapolated to CI deficient patients, these data suggest that only patients with a reduction in CI expression, rather than a decrease in CI intrinsic catalytic activity, may benefit from antioxidant treatment. This information may help to increase our understanding of different treatment responses in CI deficient children and may point to the importance of individualized treatment approaches that should not only consider genetic aspects but also cell physiological parameters. It remains an important future task to extend our current knowledge of the effects and interactions of potentially beneficial drugs on the cellular level and to translate this information to clinical practice. This will hopefully lead to the development of new disease-adapted therapeutic strategies.

Acknowledgements

We thank the patients and their families for participation.

Funding

ZON (Netherlands Organization for Health Research and Development, No. 903-46-176); NWO (Netherlands Organization for Scientific Research, No. 911-02-008); European Union's sixth Framework Programme for Research, Priority 1 'Life sciences, genomics and biotechnology for health', contract number LSHM-CT-2004-503116; 'Forschungskommission der Medizinischen Fakultät, Heinrich-Heine-University, Düsseldorf'.

References

- Anderson SL, Chung WK, Frezzo J, Papp JC, Ekstein J, Dimauro S, et al. A novel mutation in NDUFS4 causes Leigh syndrome in an Ashkenazi Jewish family. *J Inherit Metab Dis* 2008, Advance Access published on December 26, 2008, doi 10.1007/s10545-008-1049-9.
- Balaban RS, Nemoto S, Finkel T. Mitochondria, oxidants, and aging. *Cell* 2005; 120: 483–95.
- Bénit P, Beugnot R, Chretien D, Giurgea I, De Lonlay-Debeney P, Issartel JP, et al. Mutant NDUFV2 subunit of mitochondrial complex I causes early onset hypertrophic cardiomyopathy and encephalopathy. *Hum Mutat* 2003; 21: 582–6.
- Bénit P, Chretien D, Kadhon N, de Lonlay-Debeney P, Cormier-Daire V, Cabral A, et al. Large-scale deletion and point mutations of the nuclear NDUFV1 and NDUFS1 genes in mitochondrial complex I deficiency. *Am J Hum Genet* 2001; 68: 1344–52.
- Bénit P, Slama A, Cartault F, Giurgea I, Chretien D, Lebon S, et al. Mutant NDUFS3 subunit of mitochondrial complex I causes Leigh syndrome. *J Med Genet* 2004; 41: 14–7.
- Berger I, Hershkovitz E, Shaag A, Edvardson S, Saada A, Elpeleg O. Mitochondrial complex I deficiency caused by a deleterious NDUFA11 mutation. *Ann Neurol* 2008; 63: 405–8.
- Brandt U. Energy converting NADH:quinone oxidoreductase (complex I). *Annu Rev Biochem* 2006; 75: 69–92.
- Budde SM, van den Heuvel LP, Smeets RJ, Skladal D, Mayr JA, Boelen C, et al. Clinical heterogeneity in patients with mutations in the NDUFS4 gene of mitochondrial complex I. *J Inherit Metab Dis* 2003; 26: 813–5.
- Carroll J, Fearnley IM, Skehel JM, Shannon RJ, Hirst J, Walker JE. Bovine complex I is a complex of 45 different subunits. *J Biol Chem* 2006; 281: 32724–7.
- Civitarese AE, Ravussin E. Mitochondrial energetics and insulin resistance. *Endocrinology* 2008; 149: 950–4.
- Dieteren CE, Willems PH, Vogel RO, Swarts HG, Fransen J, Roepman R, et al. Subunits of mitochondrial complex I exist as part of matrix- and membrane-associated subcomplexes in living cells. *J Biol Chem* 2008; 283: 34753–61.
- Distelmaier F, Koopman WJ, Testa ER, de Jong AS, Swarts HG, Mayatepek E, et al. Life cell quantification of mitochondrial membrane potential at the single organelle level. *Cytometry A* 2008; 73A: 129–38.
- Distelmaier F, Visch HJ, Smeitink JA, Mayatepek E, Koopman WJ, Willems PH. The antioxidant Trolox restores mitochondrial membrane potential and Ca(2+)-stimulated ATP production in human complex I deficiency. *J Mol Med* 2009, Advance Access published on Mar 3, 2009, doi 10.1007/s00109-009-0452-5.
- Dröge W. Free radicals in the physiological control of cell function. *Physiol Rev* 2002; 82: 191–200.
- Duchen MR. Mitochondria in health and disease: perspectives on a new mitochondrial biology. *Mol Aspects Med* 2004; 25: 365–51.
- Dunning CJ, McKenzie M, Sugiana C, Lazarou M, Silke J, Connelly A, et al. Human CIA30 is involved in the early assembly of mitochondrial complex I and mutations in its gene cause disease. *EMBO J* 2007; 26: 3227–37.
- Fernandez-Moreira D, Ugalde C, Smeets R, Rodenburg RJ, Lopez-Laso E, Ruiz-Falco ML, et al. X-linked NDUFA1 gene mutations associated with mitochondrial encephalomyopathy. *Ann Neurol* 2007; 61: 73–83.
- Hoefs SJ, Dieteren CE, Distelmaier F, Janssen RJ, Epplen A, Swarts HG, et al. NDUFA2 complex I mutation leads to Leigh disease. *Am J Hum Genet* 2008; 82: 1306–15.
- Iuso A, Scacco S, Piccoli C, Bellomo F, Petruzzella V, Trentadue R, et al. Dysfunctions of cellular oxidative metabolism in patients with mutations in the NDUFS1 and NDUFS4 genes of complex I. *J Biol Chem* 2006; 281: 10374–80.
- Janssen RJ, Nijtmans LG, van den Heuvel LP, Smeitink JA. Mitochondrial complex I: structure, function and pathology. *J Inherit Metab Dis* 2006; 29: 499–515.
- Kirby DM, Salemi R, Sugiana C, Ohtake A, Parry L, Bell KM, et al. NDUFS6 mutations are a novel cause of lethal neonatal mitochondrial complex I deficiency. *J Clin Invest* 2004; 114: 837–45.
- Komen JC, Distelmaier F, Koopman WJ, Wanders RJ, Smeitink J, Willems PH. Phytanic acid impairs mitochondrial respiration through protonophoric action. *Cell Mol Life Sci* 2007; 64: 3271–81.
- Koopman WJ, Verkaart S, van Emst-de Vries SE, Grefte S, Smeitink JA, Nijtmans LG, et al. Mitigation of NADH: ubiquinone oxidoreductase deficiency by chronic Trolox treatment. *Biochim Biophys Acta* 2008; 1777: 853–9.
- Koopman WJ, Verkaart S, Visch HJ, van Emst-de Vries S, Nijtmans LG, Smeitink JA, et al. Human NADH:ubiquinone oxidoreductase deficiency: radical changes in mitochondrial morphology? *Am J Physiol Cell Physiol* 2007; 293: C22–9.
- Koopman WJ, Visch HJ, Verkaart S, van den Heuvel LW, Smeitink JA, Willems PH. Mitochondrial network complexity and pathological decrease in complex I activity are tightly correlated in isolated human complex I deficiency. *Am J Physiol Cell Physiol* 2005; 289: C881–90.
- Kruse SE, Watt WC, Marcinek DJ, Kapur RP, Schenkman KA, Palmiter RD. Mice with mitochondrial complex I deficiency develop a fatal encephalomyopathy. *Cell Metab* 2008; 7: 312–20.
- Landolfi B, Curci S, Debellis L, Pozzan T, Hofer AM. Ca²⁺ homeostasis in the agonist-sensitive internal store: functional interactions between mitochondria and the ER measured *In situ* in intact cells. *J Cell Biol* 1998; 142: 1235–43.
- Laugel V, This-Bernd V, Cormier-Daire V, Speeg-Schatz C, de Saint-Martin A, Fischbach M. Early-onset ophthalmoplegia in Leigh-like syndrome due to NDUFV1 mutations. *Pediatr Neurol* 2007; 36: 54–7.
- Lazarou M, Thorburn DR, Ryan MT, McKenzie M. Assembly of mitochondrial complex I and defects in disease. *Biochim Biophys Acta* 2009; 1793: 78–88.
- Lebon S, Rodriguez D, Bridoux D, Zerrad A, Rötig A, Munnich A, et al. A novel mutation in the human complex I NDUFS7 subunit associated with Leigh syndrome. *Mol Genet Metab* 2007; 90: 379–82.
- Lin MT, Beal MF. Mitochondrial dysfunction and oxidative stress in neurodegenerative diseases. *Nature* 2006; 443: 787–95.
- Loeffen J, Elpeleg O, Smeitink J, Smeets R, Stöckler-Ipsiroglu S, Mandel R, et al. Mutations in the complex I NDUFS2 gene of patients with cardiomyopathy and encephalomyopathy. *Ann Neurol* 2001; 49: 195–201.
- Loeffen J, Smeitink J, Triepels R, Smeets R, Schuelke M, Sengers R, et al. The first nuclear-encoded complex I mutation in a patient with Leigh syndrome. *Am J Hum Genet* 1998; 63: 1598–608.
- Loeffen JL, Smeitink JA, Trijbels JM, Janssen AJ, Triepels RH, Sengers RC, et al. Isolated complex I deficiency in children: clinical, biochemical and genetic aspects. *Hum Mutat* 2000; 15: 123–34.
- Luo X, Pitkänen S, Kassoovska-Bratinova S, Robinson BH, Lehotay DC. Excessive formation of hydroxyl radicals and aldehydic lipid peroxidation products in cultured skin fibroblasts from patients with complex I deficiency. *J Clin Invest* 1997; 99: 2877–82.

- Martín MA, Blázquez A, Gutierrez-Solana LG, Fernández-Moreira D, Briones P, Andreu AL, *et al.* Leigh syndrome associated with mitochondrial complex I deficiency due to a novel mutation in the NDUFS1 gene. *Arch Neurol* 2005; 62: 659–61.
- Minai L, Martinovic J, Chretien D, Dumez F, Razavi F, Munnich A, *et al.* Mitochondrial respiratory chain complex assembly and function during human fetal development. *Mol Genet Metab* 2008; 94: 120–6.
- Nicholls DG. Mitochondrial membrane potential and aging. *Aging Cell* 2004; 3: 35–40.
- Ogilvie I, Kennaway NG, Shoubridge EA. A molecular chaperone for mitochondrial complex I assembly is mutated in a progressive encephalopathy. *J Clin Invest* 2005; 115: 2784–92.
- Pagliarini DJ, Calvo SE, Chang B, Sheth SA, Vafai SB, Ong SE, *et al.* A mitochondrial protein compendium elucidates complex I disease biology. *Cell* 2008; 134: 112–23.
- Petruzzella V, Vergari R, Puziferri I, Boffoli D, Lamantea E, Zeviani M, *et al.* A nonsense mutation in the NDUFS4 gene encoding the 18 kDa (AQDQ) subunit of complex I abolishes assembly and activity of the complex in a patient with Leigh-like syndrome. *Hum Mol Genet* 2001; 10: 529–35.
- Pitkänen S, Feigenbaum A, Laframboise R, Robinson BH. NADH-coenzyme Q reductase (complex I) deficiency: heterogeneity in phenotype and biochemical findings. *J Inher Metab Dis* 1996; 19: 675–86.
- Procaccio V, Wallace DC. Late-onset Leigh syndrome in a patient with mitochondrial complex I NDUFS8 mutations. *Neurology* 2004; 62: 1899–901.
- Remacle C, Barbieri MR, Cardol P, Hamel PP. Eukaryotic complex I: functional diversity and experimental systems to unravel the assembly process. *Mol Genet Genomics* 2008; 280: 93–110.
- Rosignol R, Faustin B, Rocher C, Malgat M, Mazat JP, Letellier T. Mitochondrial threshold effects. *Biochem J* 2003; 370: 751–62.
- Saada A, Edvardson S, Rapoport M, Shaag A, Amry K, Miller C, *et al.* C6ORF66 is an assembly factor of mitochondrial complex I. *Am J Hum Genet* 2008; 82: 32–8.
- Schuelke M, Smeitink J, Mariman E, Loeffen J, Plecko B, Trijbels F, *et al.* Mutant NDUFV1 subunit of mitochondrial complex I causes leukodystrophy and myoclonic epilepsy. *Nat Genet* 1999; 21: 260–1.
- Shoubridge EA. Nuclear genetic defects of oxidative phosphorylation. *Hum Mol Genet* 2001; 10: 2277–84.
- Smeitink J, Ruitenbeek W, van Lith T, Sengers R, Trijbels F, Wevers R, *et al.* Maturation of mitochondrial and other isoenzymes of creatine kinase in skeletal muscle of preterm born infants. *Ann Clin Biochem* 1992; 29: 302–6.
- Smeitink JAM, van den Heuvel LP, DiMauro S. The genetics and pathology of oxidative phosphorylation. *Nat Rev Genet* 2001; 2: 342–52.
- Smeitink JA, van den Heuvel LW, Koopman WJ, Nijtmans LG, Ugalde C, Willems PH. Cell biological consequences of mitochondrial NADH:ubiquinone oxidoreductase deficiency. *Curr Neurovasc Res* 2004; 1: 29–40.
- Sugiana C, Pagliarini DJ, McKenzie M, Kirby DM, Salemi R, Abu-Amero KK, *et al.* Mutation of C20orf7 disrupts complex I assembly and causes lethal neonatal mitochondrial disease. *Am J Hum Genet* 2008; 83: 468–78.
- Thorburn DR. Mitochondrial disorders: prevalence, myths and advances. *J Inher Metab Dis* 2004; 27: 349–62.
- Triepels RH, van den Heuvel LP, Loeffen JL, Buskens CA, Smeets RJ, Rubio Gozalbo ME, *et al.* Leigh syndrome associated with a mutation in the NDUFS7 (PSST) nuclear encoded subunit of complex I. *Ann Neurol* 1999; 45: 787–90.
- van den Heuvel L, Ruitenbeek W, Smeets R, Gelman-Kohan Z, Elpeleg O, Loeffen J, *et al.* Demonstration of a new pathogenic mutation in human complex I deficiency: a 5-bp duplication in the nuclear gene encoding the 18-kD (AQDQ) subunit. *Am J Hum Genet* 1998; 62: 262–8.
- Verkaart S, Koopman WJ, Cheek J, van Emst-de Vries SE, van den Heuvel LW, Smeitink JA, *et al.* Mitochondrial and cytosolic thiol redox state are not detectably altered in isolated human NADH:ubiquinone oxidoreductase deficiency. *Biochim Biophys Acta* 2007b; 1772: 1041–51.
- Verkaart S, Koopman WJ, van Emst-de Vries SE, Nijtmans LG, van den Heuvel LW, Smeitink JA, *et al.* Superoxide production is inversely related to complex I activity in inherited complex I deficiency. *Biochim Biophys Acta* 2007a; 1772: 373–81.
- Visch HJ, Koopman WJ, Leusink A, van Emst-de Vries SE, van den Heuvel LP, Willems PH, *et al.* Decreased agonist-stimulated mitochondrial ATP production caused by a pathological reduction in endoplasmic reticulum calcium content in human complex I deficiency. *Biochim Biophys Acta* 2006a; 1762: 115–23.
- Visch HJ, Koopman WJ, Zeegers D, van Emst-de Vries SE, van Kuppeveld FJ, van den Heuvel LP, *et al.* Ca²⁺ mobilizing agonists increase mitochondrial ATP production to accelerate cytosolic Ca²⁺ removal: aberrations in human complex I deficiency. *Am J Physiol Cell Physiol* 2006b; 291: C308–16.
- Visch HJ, Rutter GA, Koopman WJ, Koenderink JB, Verkaart S, de Groot T, *et al.* Inhibition of mitochondrial Na⁺-Ca²⁺ exchange restores agonist-induced ATP production and Ca²⁺ handling in human complex I deficiency. *J Biol Chem* 2004; 279: 40328–36.
- Vogel RO, Smeitink JA, Nijtmans LG. Human mitochondrial complex I assembly: a dynamic and versatile process. *Biochim Biophys Acta* 2007; 1767: 1215–27.
- Willems PH, Valsecchi F, Distelmaier F, Verkaart S, Visch HJ, Smeitink JA, *et al.* Mitochondrial Ca²⁺ homeostasis in human NADH:ubiquinone oxidoreductase deficiency. *Cell Calcium* 2008; 44: 123–33.
- Yoon YS, Yoon DS, Lim IK, Yoon SH, Chung HY, Rojo M, *et al.* Formation of elongated giant mitochondria in DFO-induced cellular senescence: involvement of enhanced fusion process through modulation of Fis1. *J Cell Physiol* 2006; 209: 468–80.
- Yu T, Botham JL, Yoon Y. Increased production of reactive oxygen species in hyperglycemic conditions requires dynamic change of mitochondrial morphology. *Proc Natl Acad Sci USA* 2006; 103: 2653–8.
- Zeviani M, Carelli V. Mitochondrial disorders. *Curr Opin Neurol* 2007; 20: 564–71.