

# THE DESIGN OF SUN VISORS FOR AUTOMOTIVE INDUSTRY

Dragos TUTUNEA<sup>1</sup>, Alexandru DIMA<sup>2</sup>, Marin BICA<sup>3</sup>, Mihaela BUCULEI<sup>4</sup>

<sup>1</sup>University of Craiova, Faculty of Mechanics, dragostutunea@yahoo.com

<sup>2</sup>University of Craiova, Faculty of Mechanics, alexandru1dima@yahoo.com

<sup>3</sup>University of Craiova, Faculty of Mechanics, marinbica52@gmail.com

<sup>4</sup>University of Craiova, Faculty of Mechanics, buculeiro@yahoo.com

**Abstract**— Sun visors are used for a long time to protect the driver from the sun rays. Sun visors for an automotive vehicle have an approximately rectangular contour. They are limited since the visors are capable only to cover the superior part of the windshield. In this paper are designed several types of sun visors based on a typical sun visors from a local automotive company. These sun visors can slide axially furnishing an adjustable sun visor extension to protect against the driver dazzle present in the evening and morning hours and when the hills are climbed. The extensions are opaque and are covered with the same material as the sun visor body.

**Keywords**—automotive, sun rays, visor, windshield.

## I. INTRODUCTION

THE automotive industry has demonstrated a commitment to build safer, cheaper and better performing vehicles [1]. Currently in automotive industry and aircraft vehicles pairs of sun visors are equipped to be used by the driver and the passenger in the seat near the driver. These sun visors are separated from one another in the vehicle interior by a certain distance through which rays of light from the sun can shine in the moment when these rays are at an angle which is relative to the longitudinal axis of the car [2]. Started with the 1980s the computer-aided design programs have replaced the need of classic draftsmen, especially in small and medium companies. The ability and affordability to run these programs on personal computers allowed engineers to make the drafting work without the need of dedicated departments. Computer added design (CAD) is used by large scale in different applications such as automotive industry, aerospace and shipbuilding, architectural and industrial design, medical prosthetics, and many more [3]-[4]. The strong competition in today's market increases the level of requirement in terms of functionality and quality of products. At the same time, the complexity of the design process is increasing, whereas product development time is decreasing. Such constraints on design activities require efficient CAD systems and adapted CAD methodologies. Contemporary CAD systems, based on parametric associative technology, facilitate the creation of fully parameterized and adaptive products [5].

Concurrent engineering environment requires that various computer-aided tools be used simultaneously for design and analysis. CAD and CAE tools are supposed to have the ability of integration or co-operation. However, many of them are often stand-alone systems that are not intended for collaborative use. In addition, engineering designers and analysts tend to use specific CAD software for design and other CAE software for analysis although most CAE tools have built-in modeling features. Another disadvantage is that CAD systems offer restricted facilities for structural optimization [6]-[8]. The virtual development of complex products, like sun visors (Fig.1) in automotive engineering, is characterized by numerous influencing factors which can either stem from internal boundary conditions like product specifications or from external requirements, e.g. standards, regulations or specific customer-demands.



Fig. 1. Typical design of automotive sun visor

Based on the fact that automotive sun visors represent a main interface between customer and vehicle, visor development states an important field in automotive engineering. It represents a complex challenge in automotive engineering which is mainly caused by numerous interdependent influencing factors [9].

## II. SOFTWARE IMPLEMENTATION

Some software that satisfies the functional requirements shown in the framework can be used to implement the integration and optimization processes. Different software's are used in automotive industry

especially to reduce the cost and in the same time to remain profitable while delivering the products on time. The development process requires the use of 2D drawings and the 3D design and modeling to improve the production. SolidWorks's offer the users the ability to design better parts and a wide range of products. A variety of SolidWorks's function can be accessed from SolidWorks's macro files Visual Basic.NET and Visual Basic without the necessity to use a graphic interface. SolidWorks's has the most accessible interface and easiest of the 3D design system and can be successfully implemented in the design and production of different components used in the automotive industry [6].

### III. METHODS AND MATERIALS

Modern CAD systems offer a variety of tools to increase the flexibility of geometric models. The most significant influencing factors are caused by safety requirements due to the direct human interaction with sun visors. Besides standard demands regarding stability of sun visors a large number of further safety issues, especially regarding the anchorage positions are regulated by legislation. All the different variants of sun visors configurations have to meet these strong legislative boundary conditions to reach an admission to the related markets.

There are numerous types of sun visors used currently in the automotive market place which have been widely tested. The virtual design of the sun visor must include an accurate estimate of space required in the auto vehicle interior, weight and structural integrity in case of accidents.

In this study the authors use SolidWorks software program to design and build several models of sun visors for automotive industry based on a sun visors from a local automotive company (Fig. 2). The sun visors are composed by two plates and a covering material (Fig.3).



Fig. 2. Sun visor used as model for study

For this study the authors have studied different type of sun visors to obtain the best design for automotive industry and other applications. This design can also be used in educational applications to show the wide versatility of CAD software in automotive industry.



Fig. 3. Component elements of sun visor

The material selection is another critical part of the sun visors design process. Materials used in the sun visors have crucial influence on the final cost as well as the structural and shape characteristics.

### IV. RESULTS AND DISCUSSION

In the day period are two moments when the sun is low in the sky at the sunrise and in the sunset. These situations create a difficult driving condition when the driver is affected by the sun. In the moment when the sun is low in the sky his light is pointed into the driver's eyes, blinding the driver. The sun visors have a limited effect because the pair only can cover the superior part of the windshield. In the present the sun visors don't have a height to allow the protection against the sun rays. The object of the study is to enhance the visor capability to protect against dazzle, to design a simple, efficient and economical sun visor. The 3D model of the sun visor was obtained with SolidWorks program (Fig. 4). Based on this model the authors designed several models of sun visors presented below. All the proposed solutions are designed according to automotive standards. A thermoplastic covering is used to reduce the price of the sun visors.

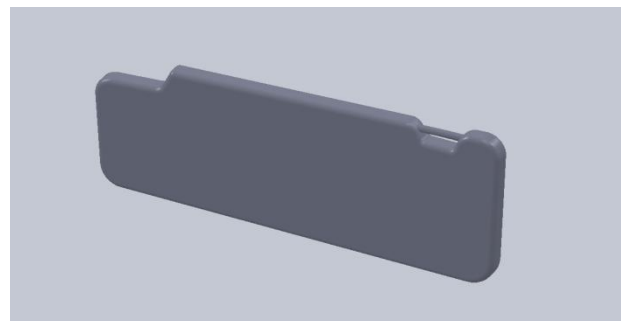

Fig. 4. 3D model of sun visor

In Fig. 5 is presented a perspective view of first design of the opaque extension mounted on the automotive sun visor. The extension can slide into the sun visor body and extend vertically on 50 mm distance to protect the driver from the sun rays. The design of the sun visor main body Fig.6 in two different parts and connecting them to move

relative to each other it is possible slide the entire sun visor in front as in the traditional manner and to slide variably his lower part to achieve a good protection of the driver in the morning and evening dazzle.

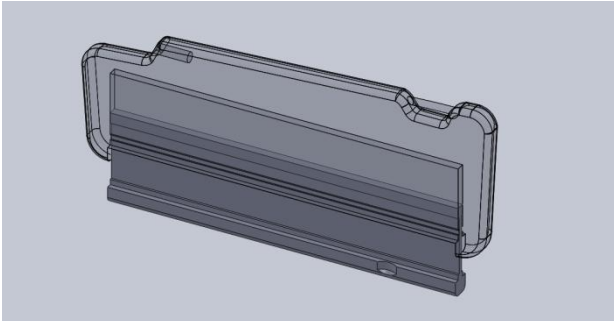

Fig. 5. Sun visor with an extension mounted inside the core of the visor

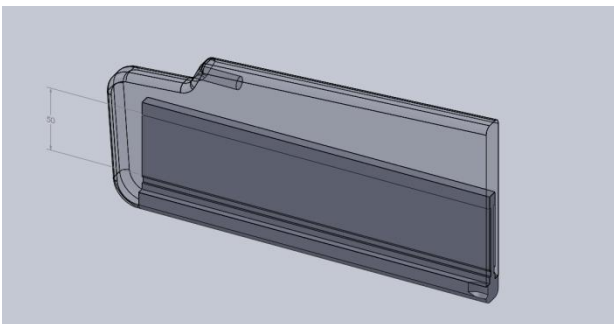

Fig. 6. Cut plot of glide elements of sun visor

The second design (Fig. 7) has an extension which can slide on a distance of 60 mm. Also the design has a mirror on the interior of the main body of the sun visor. The extension has the same material like the body of the sun visor or smoke gray, color which tend to block the passage of the solar rays.

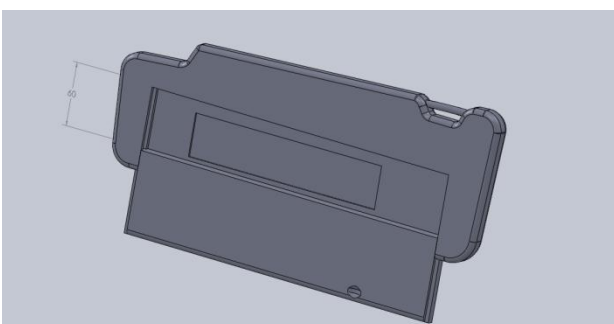

Fig. 7. Sun visor with an exterior extension and a back mirror

The third design (Fig. 8) relates to a sun visor is equipped to be placed near the rearview mirror and protect from sun rays in certain moments of the day. The windshield surrounding the rear view is not protected by commercial sun visors. When the sun is low in the sky these sun rays will pass in the area between the rearview mirror and dazzle the driver. The sun visor slide back and forth completely without noise in the axial direction on a distance of 85 mm.

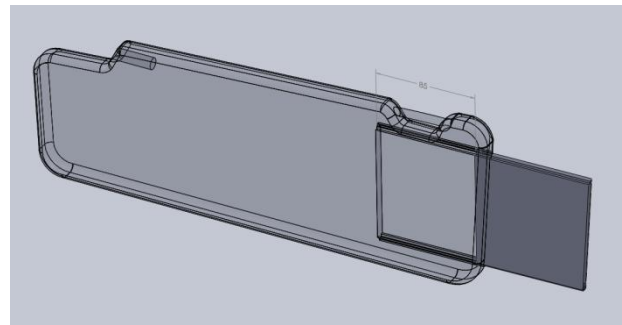

Fig. 8. Sun visor with horizontal extension

The fourth design (Fig.9) has an opaque extension fitted on an automotive sun visor which can rotate on 180 degrees to block the sun rays. The extension can reach 70 mm in length to block the sun rays.

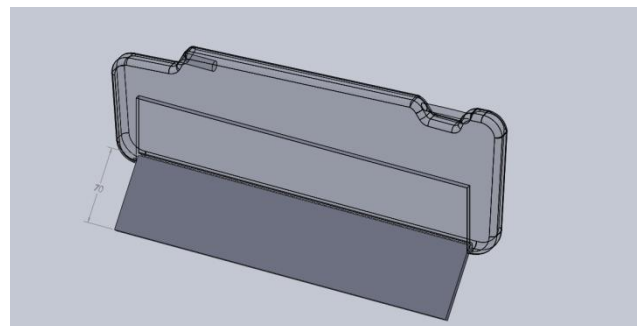

Fig. 9. Sun visor with folding extension

The fifth design (Fig. 10) is separated in two parts which can move along several guiding pins back and forth from each resulting in lengthening or shortening the height of projected sun visors on a distance of 80 mm. These pins are projected so the pins from lower edge and the upper part to move in such manner that the superior part and inferior part can move together and apart. To be simple and economical to manufacture this type of sun visor the superior part may be suitable to comprise a plastic injection molding and the inferior part to have a cushioning body with a reinforcing insert with pins constructed in it.

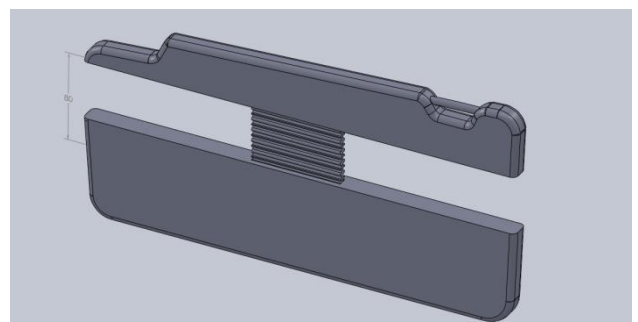

Fig. 10. Sun visor with guide pins

The sixth designs (Fig. 11) proposed are a combination between first and third design of sun visors. This design covers the problems encountered by the event that the driver which uses this design is short of stature and the extension may be oversized to permit it to be adjusted

downwardly on the projected visor. By developing the sun-visor body in three parts and by connecting the three parts so that they are movable relative to each other, is possible to both swings the sun visor body in both directions to obtain a maximum protection against dazzle.

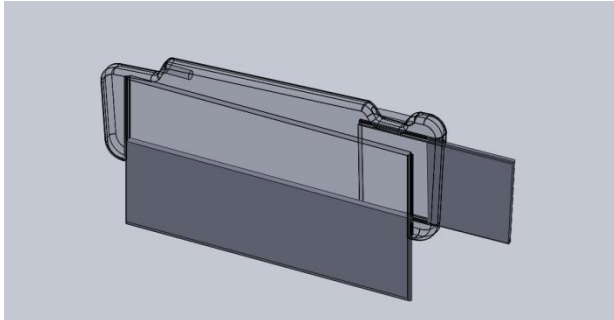

Fig. 11. Sun visor with vertical and horizontal extension

The seventh design (Fig. 12) has two extensions which allow sun visor to slide vertically and horizontally to protect the driver from the sun rays. This approach which is pointed more to aspect of the product than utility has sharpened edges which also complicate the manufacturing process which implies a higher production cost and more important, may lead to head injury in the case of car accidents. The two extensions glide completely inside the core of the sun visor.

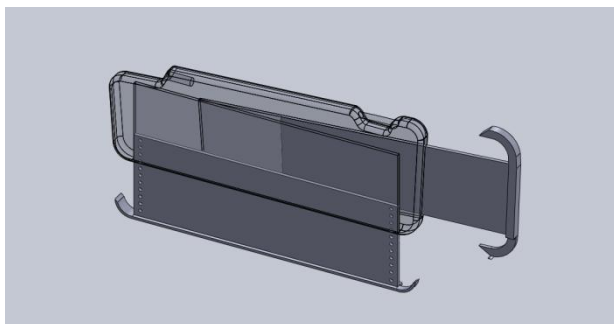

Fig. 12. Sun visor with dual protective extensions

TABLE I  
 SLIDE DIMENSION

Sun visors	Type of slide [mm]	
	Vertical	Horizontal
Design 1	50	-
Design 2	60	-
Design 3	-	85
Design 4	70	-
Design 5	80	-
Design 6	50	85
Design 7	95	280

All the designs proposed for sun visors maintain the same shape of the model analyzed. These designs can be quickly implemented in automotive industry do to the fact that they don't need any modification for the fastening of the panel on the roof of the car. In the table I are presented the maximum dimension for all the designs of the sun visors.

## V.CONCLUSION

3D CAD software proves to be a very useful component in order to design any mechanical or manufacturing parts with high accuracy for the automotive industry. The study started from the analysis of the design of a sun visor used by a local automotive company and the demands of the customers related to some of the missing features of this part that can offer more with less effort. Afterwards, seven models of sun visors were designed and analyzed with regard over their capability to protect the driver from the dazzle of the sun and provide proper conditions for driving. Another aim of the study is that the production cost/materials and technology to be in the same range with initial product without increasing very much the production costs. The example presented deals with automotive industry purpose; but the methodology can be applied in any domain required CAD modeling. Future work is needed for sun visors production as well as the cost and structural analysis to establish if the proposed models of sun visors meet legal requirements for automotive implementations.

## ACKNOWLEDGMENT

"This work was partially supported by the grant number 4C/27.01.2014, awarded in the internal grant competition of the University of Craiova"

## REFERENCES

- [1] K. Karakoc, E. J. Park and A. Suleman, "Design considerations for an automotive magnetorheological brake", *Mechatronics* vol. 18, 2008, pp. 434-447.
- [2] A., Lichtenstein, V. Petrucci, M.P. Anderson, "Adjustable automotive and aircraft sun visor extension", US patent, oct. 2, 1979.
- [3] MD. H. Ali, A. Katsuki, S. Kurokawa and T. Sajima, "Design of Mechanical Actuator in 3D CAD Software", *Procedia Engineering* vol. 64, 2013, pp.473 - 478.
- [4] H. Pottmann, S. Brell-Cokcan, and J. Wallner. "Discrete surfaces for architectural design". *Curves and Surface Design: Avignon 2006, 2007*, pp 213-234.
- [5] Y. Bodein, B. Rose and E. Caillaud, "Explicit reference modeling methodology in parametric CAD system", *Computers in Industry*, vol. 65, 2014, pp. 136-147.
- [6] H.-S. Park and X.-P. Dang, "Structural optimization based on CAD-CAE integration and metamodeling techniques", *Computer-Aided Design* vol. 42, 2010, pp. 889-902.
- [7] F. Bianconi, P. Conti, N. Senin and D.R. Wallace, "CAE systems and distributed design environments", *XII ADM international conference*, Italy: Sept, 2001.
- [8] H.S. Park, G.B. Lee and H. Kim, "Collaborative engineering system supporting product development process", *ASME design engineering technical conferences 2003*, Chicago, USA, Vol. 1, Part B., pp. 873-80.
- [9] S. Stadler and M. Hirz, "An Application of Enhanced Knowledge-Based Design in Automotive Seat Development", *Computer-Aided Design & Applications*, 11(3), 2013, pp. 335-345.