

PSFC/JA-08-20

**An accelerator based fusion-product source
for development of Inertial Confinement Fusion
nuclear diagnostics**

S.C. McDuffee, J.A. Frenje, F.H. Séguin, R. Leiter,
M.J. Canavan, D.T. Casey,
J.R. Rygg, C.K. Li, and R.D. Petrasso

18 June 2008

Plasma Science and Fusion Center,
Massachusetts Institute of Technology, Cambridge,
MA 02139 USA

This work was supported in part by LLE (subcontract Grant No. 412160-001G), LLNL (subcontract Grant No. B504974), the U.S. DoE (Grant No. DEFG03-03SF22691), the Univ. of Rochester, and the N.Y.State Energy Research and Development Authority.

Published in *Review of Scientific Instruments*.

An accelerator based fusion-product source for development of Inertial Confinement Fusion nuclear diagnostics

S.C. McDuffee, J.A. Frenje, F.H. Séguin, R. Leiter, M.J. Canavan, D.T. Casey, J.R.

Rygg⁽ⁱ⁾, C.K. Li, and R.D. Petrasso⁽ⁱⁱ⁾

MIT Plasma Science Fusion Center, Cambridge, Massachusetts 02139

Abstract

A fusion product source, utilizing a 150 kV Cockraft-Walton linear accelerator, has been refurbished to provide a reliable nuclear diagnostic development tool to the national Inertial Confinement Fusion (ICF) research program. The accelerator is capable of routinely generating DD reaction rates at $\sim 10^7$ per second when using a 150 kV, 150 μ A deuterium (D) beam onto an erbium (Er) or titanium (Ti) target doped with D, and D³He reaction rates at $\sim 5 \times 10^5$ per second when using a using a 120 kV, ~ 100 μ A D beam onto a Er or Ti target doped with ³He. The new accelerator is currently being used in a number of projects related to the national ICF program at the OMEGA Laser Fusion Facility [T.R. Boehly *et al.*, Opt. Commun. **133**, 495 (1997)], which includes the Wedge Range Filter charged-particle spectrometry program [F.H. Seguin *et al.*, Rev. Sci Instrum. **75**, 3520 (2004)] and the Magnetic Recoil neutron Spectrometer [J.A. Frenje *et al.*, Rev. Sci. Instrum. **72**, 854 (2001)].

I. Introduction

A Cockraft-Walton (CW) linear accelerator has been refurbished for Inertial Confinement Fusion (ICF) diagnostic development. Originally manufactured by Texas Nuclear Corp. as a neutron generator¹, it was converted for use as a fusion product source as described in Ref. 2. Since then, the device has been modified significantly to improve the quality of the source and to increase its capability and flexibility as a diagnostic development tool. In particular, the accelerator has been optimized for testing, characterizing, and calibrating nuclear diagnostics used in the national ICF program. The modifications made to the accelerator have already had an impact on the charged particle spectrometry program at the OMEGA laser fusion facility. In addition, the accelerator has been used to characterize and calibrate charged-particle diagnostics used on the Alcator C-Mod tokamak³. Other fusion product sources used for similar purposes exist at Colorado School of Mines and State University of New York at Geneseo.^{4,5}

This paper is structured as follows: Section II describes the accelerator's main components, as well as hardware and software upgrades. The diagnostic updates to the accelerator are described in Section III. Section IV presents a brief discussion of fusion-product generation, while sections V and VI describe current and future projects.

II. Systems and Upgrades

A. Hardware

In the CW-linear accelerator (Fig. 1), either ^3He or D_2 gas is fed into an ionization bottle through a Granville-Phillips 203 variable leak valve. Two 60-MHz RF rings around the bottle ionize the gas. When a plasma has been generated, an extraction electrode draws the ions from the ionization bottle through a variable potential up to 5 kV. A solenoid compresses the plasma onto an extraction axis and the beam is pulled down an accelerating tube with a variable potential of up to 150 kV.

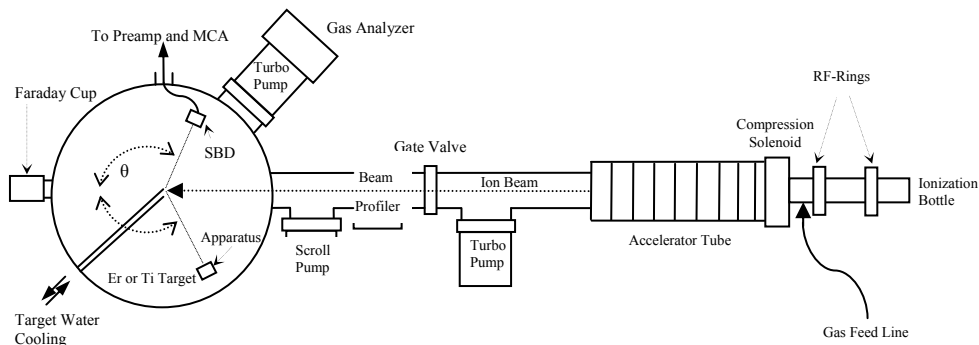

Fig. 1. A schematic drawing of the upgraded accelerator. Either ^3He or D_2 gas is fed into an ionization bottle where the gas is ionized by two RF-rings. The solenoid compresses the resulting plasma onto an extraction axis and the ions are accelerated through the accelerator tube. Energies up to of 150 kV can be achieved. The versatility of the new target chamber design offers a near 180 degree view of the target while the inclusion of new diagnostic systems makes the system ideal for detector tests using light-ion fusion products.

The electronic control systems that govern the RF-rings, solenoid, extraction voltage, and various other systems have been upgraded to allow for remote computer control. A National Instruments (NI) FieldPoint system has been installed and programmed to control and monitor these systems.

The original accelerating tube has been replaced with one designed and built by Potentials Inc.⁶. The new tube improves beam focus and offers better protection from electrical breakdown. It also offers easier internal access making it simpler to maintain and clean.

The vacuum system has been upgraded to allow for different components to be pumped on separately. A gate valve after the accelerating tube, but before the target chamber, splits the system into two primary sections (Fig. 1). Each section has its own vacuum system, which allows the beam source side of the accelerator to remain under vacuum while the target chamber is vented. This dual system significantly shortens the pump down and venting time and keeps air

contaminants away from the ion-source plasma. Vacuum on the beam source side is maintained by a Leybold TurboVac 151 rotary vane turbomolecular pump backed by a Leybold SC 5 scroll pump. The vacuum on the target side is maintained by a Leybold TurboVac 361 rotary vane turbomolecular pump backed by a Leybold SC 15 scroll pump; the oil free pumping system significantly eases maintenance schedules. In addition, connections are built-in to allow for the insertion of leak detector systems. The base pressure is typically $\sim 5 \times 10^{-7}$ Torr, and the operating pressure ranges from 1×10^{-6} Torr to $\sim 3 \times 10^{-5}$ Torr depending on setup conditions. Additional valves have been connected to allow the vacuum systems to pump on a new gas-feed system. This gas-feed system allows for quick cycling of different beam species.

The most significant upgrade to the CW linear accelerator has been the installation of a new target chamber. The chamber, built by Systems Design and Fabrications⁷, was designed to significantly increase the capability and flexibility of the system. Its shape is cylindrical, approximately 66 cm in diameter and 22.4 cm tall. The baseplate is welded to the chamber with an 8" conflat (CF) port through which a linear feedthrough is attached to raise and lower calibrated radiation sources. Rotary motion feedthroughs through the baseplate allow detector positions relative to the beamline to be changed without breaking vacuum. The cover is a removable 0.75" thick highly polished stainless steel plate that seals via a large diameter viton o-ring, allowing for quick removal and replacement. Eight 8" CF ports, with mounted viewports, are built into the cover. Around the chamber, 8" CF ports are mounted at 45 degree intervals from the beamline to accommodate feedthroughs and detectors. The beamline itself is made of 4.5" CF hardware. Inside the chamber, detectors and apparatus can be mounted out to a radius of 26 cm and be positioned continuously at angles from 8 to 172 degrees with respect to the beam. (Fig. 1)

A new target delivery system has been mounted onto the target chamber. The system utilizes a 3-axis motorized feedthrough positioning system developed by MDC⁸, allowing for accurate, remote target positioning during a run. The target, which consists of either an erbium (Er) or titanium (Ti) disk fastened onto a copper end cap that is brazed to a water-cooled feedthrough, can now be fully inserted into, or removed from, the beamline.

In addition to these refurbishments, a completely new power system has been designed and installed on the accelerator, which is more compact than the original and incorporates many new safety precautions such as door interlocks and tighter current overload switches. The new system can also be monitored and controlled remotely with newly developed software.

B. Software

New software has been developed using NI's LabView architecture to incorporate all measurement and control systems into one software platform. Employing the NI FieldPoint system mentioned above, a simple graphically based user interface now controls all the electronic systems necessary for operating the accelerator. The control software has switches for controlling power to the RF rings, the compression solenoid, and the solenoid water cooling system. Beam voltage measurements are presented in real-time. There are dials and feedback for controlling and monitoring the extraction voltage as well as the voltage across a beam focus electrode. This same interface also allows for real-time monitoring of beam voltage, beam current, vacuum pressure in multiple parts of the system, and temperature measurements taken from the compression solenoid and other locations. DAQ software, developed by Canberra (Genie 2K), runs concurrently with the control software to read data from an MCA (Multiport II from Canberra) in real-time. The MCA is connected to the silicon-barrier detector (SBD) setup described in the next section.

III. Diagnostics and Upgrades

The primary charged-fusion-product diagnostics are two fully-depleted, 2000 μm thick, in-vacuum Silicon-Barrier Detectors (SBD) that are covered with 1.5 μm of Mylar shielding for protection from backscattered beam ions. In addition, the SBD's have a 100% detection efficiency and an energy resolution of ~ 17 keV when detecting 5.5 MeV alphas from an ^{241}Am source. The measured fusion-product spectrum is calibrated by the known spectrum from a ^{226}Ra source (Fig. 2), which can be raised into, or lowered from, the vacuum chamber. If further calibration is required, a ^{241}Am source can also be mounted in the chamber. Kinematic energy calculations for the fusion products have been performed and compared to measured fusion-product spectra calibrated by the ^{226}Ra spectrum. An agreement within 3% was achieved.

The inclusion of beamline diagnostics has improved the characterization of the accelerator ion beam. A National Electrostatics Beam Profile Monitor (FP3A) has been installed in-line with the beam before it enters the target chamber. The detector is connected to a Tektronix TDS 3024B oscilloscope to allow for real time measurements of the size, shape, position, and intensity of the beam. Beam spot sizes on target are typically between 5 and 12 depending on acceleration, extraction, and focus voltages. A Faraday Cup built by Princeton Scientific⁹, for absolute measurements of the beam current (accuracy: ± 0.5 μA), has been installed behind the target. The extraction of the target thus allows for absolute measurements of the beam current using the Faraday cup.

An Extor XT100M gas analyzer has also been installed behind the turbo pump on the target chamber, allowing for real-time mass spectrometry to be performed on the chamber's vacuum.

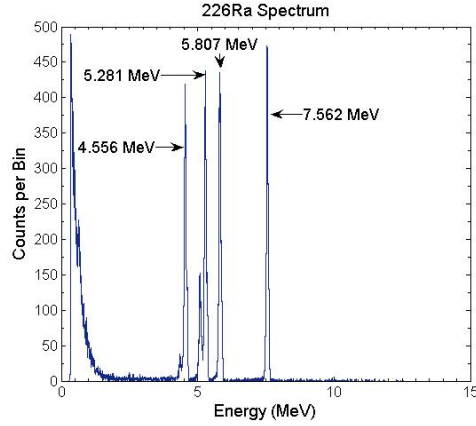
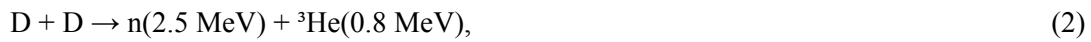

Fig. 2. A ^{226}Ra spectrum taken with a 2000 μm thick, fully depleted SBD. This spectrum is used for calibrating the MCA. The peaks have FWHM of ~ 80 keV.

In addition, a high-precision voltage divider developed by Gamma High Voltage Research has been installed and connected to a Signametrics SMX 2060 DMM PXI card to allow for highly accurate measurement of the accelerating voltage.

IV. Fusion Product Generation

Deuterium-deuterium (DD) or deuterium- ^3He (D^3He) reactions are generated by accelerating D or ^3He ions onto deuterated or ^3He -implanted Er or Ti targets:



Er and Ti are chosen as target materials because they each have some of the largest affinities for hydrogen.¹⁰ These deuterated or ^3He -doped targets are manufactured on the accelerator by embedding beam ions in the targets using the accelerator. Typically, a 120 kV, $\sim 100 \mu\text{A}$, ^3He beam is used to dope the targets. After 10 minutes, progressively lower potential/current beams are used for longer periods for a total doping time of ~ 1 hour. D beams are often used to dope the

target as well. Doping with the different beam ions leads to different reaction rates for the reactions listed above. At a standard run of a 120 kV, $\sim 100 \mu\text{A}$ D beam onto a ^3He doped Er

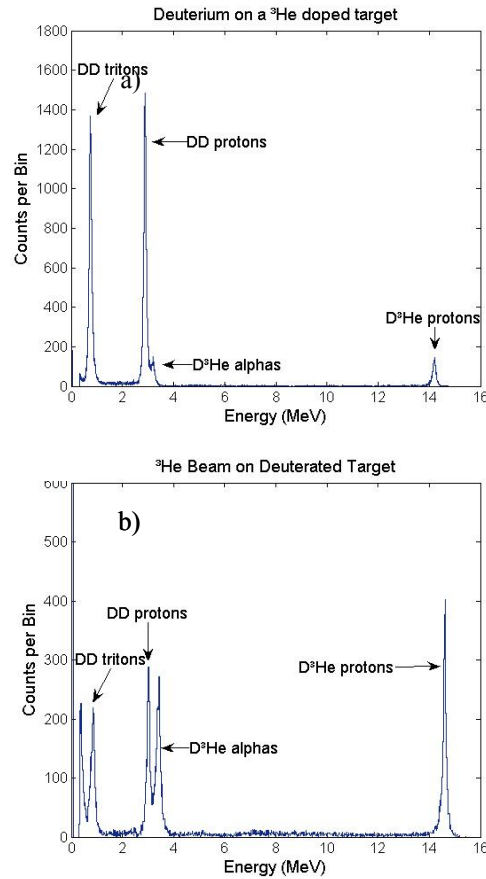

Fig. 3. (a) A typical fusion-product spectrum taken while running a 120 keV D beam onto an Er target doped with ^3He ions. At this beam energy, the DD reaction rate is ~ 8 times higher than the D ^3He reaction rate. Notice that the ^3He ions from reaction (2) are missing as the ^3He ion is ranged out in the protective Mylar that covers the SBD. This spectrum was taken at 125° relative to the beam direction and accounts for the observed downshifted energies. At 90° relative to the beam, D ^3He protons exit the target at ~ 14.6 MeV whereas here they are registered at ~ 14.2 MeV, consistent with relativistic kinematic calculations. (b) A spectrum taken while running a ^3He beam onto a deuterated Er target. The beam energy on target is once again 120 keV. The SBD was positioned at 90° relative to the beam rather than 125° as in Fig. 3a resulting in higher particle energies. The system still allows for residual D in the beam hence the presence of fusion products from reaction (1).

target, the D ^3He reaction rate is $\sim 5 \times 10^5$ per second and the DD reaction rate (obtained by measuring the 3-MeV protons) is $\sim 4 \times 10^6$ per second (Fig. 3a). When bombarding a well

deuterated target with a 150 kV, 150 μ A D beam, the DD reaction rate can be as high as $\sim 10^7$ per second while the D^3He reaction is $\sim 10^5$ per second. In this case, the observed D^3He fusion products are the result of secondary reactions stemming from 3He ions generated in the target by reaction (2). When bombarding a well deuterated target with a 3He beam (Fig. 3b), D^3He reaction rates and DD reaction rates are comparable at $\sim 5 \times 10^4$ per second. The DD reactions are a result of the residual D in the beam. If high-energy D^3He protons are used for detector tests and calibration, the contaminant charged fusion products from the DD reaction can be easily filtered out.

Particle energies in the laboratory system depend on beam energy and observed angle relative to the beam direction due to kinematic effects. This allows for a “tunable” source of monoenergetic particles as shown in Fig. 3a. For example, using a 120 keV D beam onto a 3He -implanted target, energies from 13.9 to 15.4 MeV can be achieved by varying the lab angle from 172° to 8° relative to the direction of the incoming beam.

V. Current Work

A number of projects relevant to the ICF program have already been realized with the help of the upgraded accelerator. One such project is the characterization of CR-39¹¹ that is used extensively for fusion product counting and charged-particle spectroscopy. CR-39 is a passive Solid State Nuclear Track Detector (SSNTD) that is used extensively in ICF research.^{12,13} Currently, its properties as a detector under various exposure, etching, and handling conditions are being investigated using the accelerator. This information will be of importance for development and extension of current and planned CR-39 based programs at OMEGA and the National Ignition Facility (NIF).¹⁴

CR-39 is a detector used in several diagnostic systems at the OMEGA Laser Facility. One such diagnostic system utilizes CR-39 placed behind a Wedge Range Filter (WRF)¹³ for spectral measurements of D^3He protons. These WRF spectrometers have been used extensively on OMEGA since 2001 when they were initially calibrated (Fig. 4). The accelerator was used to test whether the harsh conditions inside the OMEGA target chamber have had any impact on this calibration. Early results show that the WRF spectrometers may have lost some material and are now giving slightly higher energies (~ 100 keV) than initially. The degradation, which seems to be uniform across all the WRF spectrometers in use, will be corrected for.

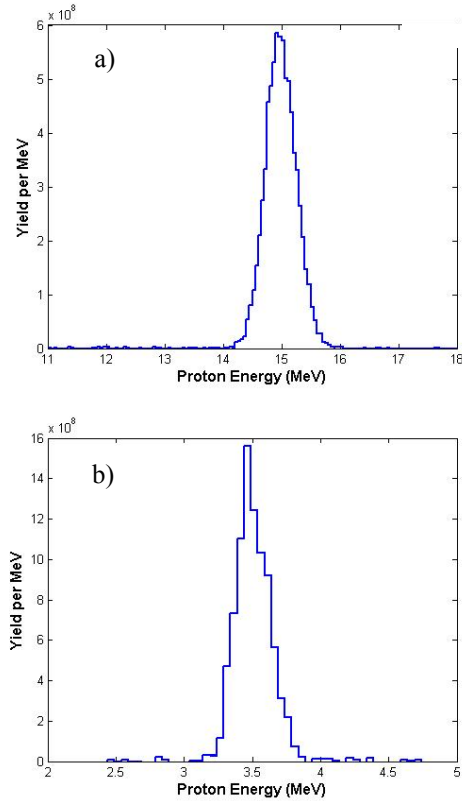

Fig 4 (a) D³He proton spectrum measured by a WRF spectrometer for OMEGA implosion 46529 (12 atm ³He fuel and 6.1 atm of D₂ fuel filled in a 2.2 μm thick SiO₂ shell). A mean energy of 14.9 MeV and yield of 3.8×10⁸ was observed for this particular implosion. (b) DD proton spectrum measured by the magnet-based CPS spectrometer for OMEGA implosion 46532 (16 atm ³He fuel and 6.1 atm of D₂ fuel filled in a 2.3 μm thick SiO₂ shell). The proton energies here are primarily upshifted because of electric fields generated around the imploding capsule¹⁵. The accelerator has been instrumental in calibrating and re-calibrating these spectrometers.

A new generation of WRF spectrometers¹⁶ have been designed and built for measurements of several fusion products at OMEGA. They feature many improvements, including the ability to detect protons with energies as low as 3 MeV, and therefore probe denser plasmas that are created in low-adiabat cryogenic implosions.¹⁷ An absolute calibration of these spectrometers is currently underway using the accelerator. Using two filters of aluminum in front of the WRF, a discrete 3-line proton spectrum is being generated and used for the calibration (Fig. 5). With proper filter combinations, practically any number of spectral lines can be produced simultaneously using the accelerator.

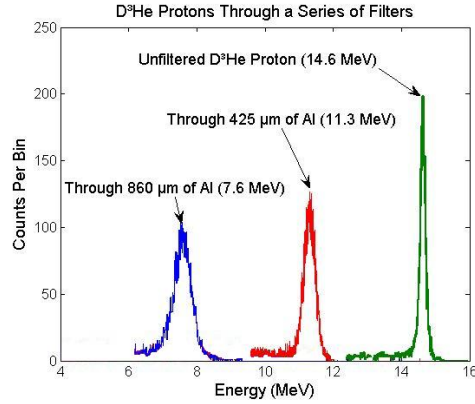

Fig 5. A discrete 3-line D³He proton spectrum used to calibrate the new mWRF spectrometers. The generation of the three lines is accomplished on the accelerator by first generating D³He protons through reaction (3) and then overlaying the spectrometer with a two-step aluminum filter with thicknesses of 425µm and 860µm respectively. The accelerator can then be used to produce protons at different energies simultaneously.

The accelerator has also been instrumental in the development of the new CR-39 based Magnetic Recoil Spectrometer (MRS)², currently being activated on the OMEGA and developed at the NIF. The MRS uses very thin CR-39 detectors (between 150 µm and 350 µm). The response of these thin CR-39 detectors to charged particles is relatively unknown, and the accelerator is currently being used to study their properties. The MRS is also sensitive to neutron background that complicates the analysis of data taken. A new background-rejection method utilizing stacked pieces of CR-39 has therefore been developed utilizing the accelerator.¹⁸

In addition to aiding the ICF program, back-scattered beam deuterons, produced in the accelerator, have been used to calibrate the Compact Neutral Particle Analyzer (CNPA), which is used to measure energetic minority ions in Alcator C-Mod plasmas.¹⁹

The accelerator has also been used to study the response of a new fluorescent nuclear track detector²⁰ (FNTD) to charge particles. Incident particles ionize the crystal matrix, recharging color centers in a Al₂O₃:CMg crystal that are later non-destructively read using laser scanning and a confocal fluorescence detection technique.²¹ The accelerator has been used to study the relation between proton energy and fluorescence track amplitude in energy ranges of interest to the national ICF program. The FNTD has been developed by the Stillwater Crystal Growth Division of Landauer Inc.

VI. Future Work

There are a number of future projects planned with the accelerator in mind. For the immediate future, the accelerator will continue to be used to characterize the properties of CR-39. Effects due to age of the detector, thickness of the material, and different etch conditions will be studied using the accelerator. In addition, early results show that the response of CR-39 to charged-particles of a given energy and for a set of given etch conditions varies depending on the manufacturer. The properties of the CR-39 from different vendors will therefore be studied on the accelerator.

Recently there have been advances in using monoenergetic protons to image ICF target implosions utilizing CR-39. This technology has opened up new areas of research especially looking at electric and magnetic field generation, as well as field reconnection, which occurs in high-density plasmas²². To develop this technology further, effects of proton scattering will be studied using the accelerator.

In addition to these projects, it has been proposed to investigate the single-event response of CVD diamond detectors for ICF applications.

VII. Conclusion

The 150 kV CW linear accelerator has undergone a number of modifications and improvements. The hardware upgrades have provided a robust and versatile platform for nuclear diagnostic development in the national ICF program while new software has extended and simplified its use. New diagnostics have been implemented to improve the capability of the accelerator, which has already been put to use to calibrate the WRF spectrometers, widely used in the OMEGA ICF program. A new generation of WRF spectrometers is currently being calibrated on the accelerator as well. The accelerator has also been employed to advance the MRS, a neutron spectrometer installed on OMEGA. Each of these diagnostic systems relies on CR-39 as its primary detector. A complete study of the CR-39 response to charged particles is currently underway using the accelerator.

Acknowledgments

The authors would like to thank Irina Cashen and Jocelyn Schaeffer for all the help they have given on this work. We would also like to thank Bob Childs for lending his vast expertise in vacuum systems. This work was supported in part by LLE (subcontract Grant No. 412160-001G), LLNL (subcontract Grant No. B504974), the U.S. DoE (Grant No. DEFG03-03SF22691), the Univ. of Rochester, and the N.Y.State Energy Research and Development Authority.

References

- ¹ J.T. Prud'homme, Texas Nuclear Neutron Generators, Texas Nuclear Corp. Publications No 5845 (1962).
- ² K.W. Wenzel, D.H. Lo, R.D. Petrasso *et al.*, Rev. Sci. Instrum. **63**, 4837 (1992).
- ³ M. Greenwald *et al.*, Nucl. Fusion **45**, S109 (2005).
- ⁴ Kurt Fletcher, private communication
- ⁵ F.E. Cecil *et al.*, Nucl. Instrum. Meth. B **40**, 934 (1989).
- ⁶ Potential Inc. 1704 Hydro Drive, Austin TX 78728 www.potentialsinc.com
- ⁷ Systems Design & Fabrication Inc. 145 Globe St. Fall River, MA 02724
www.systemfab.com
- ⁸ MDC Vacuum Products, LLC. 23842 Cabot Blvd, Hayward, CA 94545
www.mdcvacuum.com
- ⁹ Princeton Scientific Corp. P.O. Box 143 Princeton, NJ 08540
www.princesci.com
- ¹⁰ N.A. Galaktionowa, *Hydrogen-Metal Systems Databook* (Ordentlich, Holon, Israel, 1981).
- ¹¹ S.C. McDuffee, *et al.*, to be submitted to Nucl. Instrum. Meth. (2008).
- ¹² R.L. Fleisher, P.B. Price, and R.M. Walker, *Nuclear Tracks in Solids, Principles and Applications* (University of California Press, Berkeley, 1975).
- ¹³ F.H. Seguin *et al.*, Rev. Sci Instrum. **75**, 3520 (2004).
- ¹⁴ G.H. Miller *et al.*, Nucl. Fusion **44**, S228 (2004).
- ¹⁵ D.G. Hicks, *et al.*, Phys. Plasmas **7**, 5106 (2000).
- ¹⁶ F.H. Seguin *et al.*, to be submitted to Rev. Sci. Instrum. (2008).
- ¹⁷ T.C. Sangster *et al.*, Phys. Plasmas **10**, 1937 (2003).
- ¹⁸ D.T. Casey *et al.*, to be submitted to Rev. Sci. Instrum. (2008).
- ¹⁹ V. Tang *et al.*, Rev. Sci. Instrum. **77**, 083501 (2006).
- ²⁰ G.M. Akselrod, M.S. Akselrod, E.R. Benton, and N. Yasuda, Nucl. Instrum. Meth. B **247**, 295 (2006).
- ²¹ M.S. Akselrod, R.C. Yoder, and G.M. Akselrod, Rad. Prot. Dosim. **119**, 357 (2006).
- ²² J.R. Rygg *et al.*, Science **319**, 1223 (2008).