

Article

Evaluation of the Effects of Mitigation on Methane and Ammonia Production by Using *Origanum vulgare* L. and *Rosmarinus officinalis* L. Essential Oils on *in Vitro* Rumen Fermentation Systems

Gabriella Cobellis ¹, Alessandro Petrozzi ^{2,*}, Claudio Forte ¹, Gabriele Acuti ¹, Mara Orrù ¹, Maria Carla Marcotullio ³, Andrea Aquino ², Andrea Nicolini ², Valentina Mazza ² and Massimo Trabalza Marinucci ¹

¹ Department of Veterinary Medicine, University of Perugia, via S. Costanzo 4, 06126 Perugia, Italy; E-Mails: gabriella.cobellis@studenti.unipg.it (G.C.); claudio.forte@studenti.unipg.it (C.F.); gabriele.acuti@unipg.it (G.A.); maraorru@gmail.com (M.O.); massimo.trabalzamarinucci@unipg.it (M.T.M.)

² CIRIAF, Interuniversity Research Centre on Pollution and Environment “Mauro Felli”, via G. Duranti 67, 06125 Perugia, Italy; E-Mails: aquino@crbnet.it (A.A.); andrea.nicolini@unipg.it (A.N.); mazza@crbnet.it (V.M.)

³ Department of Pharmacy, University of Perugia, via A. Fabretti 48, 06123 Perugia, Italy; E-Mail: mariacarla.marcotullio@unipg.it

* Author to whom correspondence should be addressed; E-Mail: petrozzi@crbnet.it; Tel.: +39-075-585-3806; Fax: +39-075-515-3321.

Academic Editors: Francesco Asdrubali, Pietro Buzzini and Marc A. Rosen

Received: 20 May 2015 / Accepted: 16 September 2015 / Published: 18 September 2015

Abstract: The effects of increasing concentrations of oregano (*Origanum vulgare* L.) and rosemary (*Rosmarinus officinalis* L.) essentials oil (EO) on ruminal gas emissions were tested *in vitro* using 50 mL serum bottles. Each bottle contained a 200 mg substrate (alfalfa hay and corn meal 1:1) and a 20 mL solution composed of a buffered medium and rumen fluid (1:2). The percentage of ruminal fermentation products was quantified by an infrared analyzer. The reduction of total gas production was 6% and 9% respectively when using the 1.5 and 2.0 g/L oregano EO measurements. The reduction of methane production was 55%, 72% and 71% respectively with regard to the 1.0, 1.5 and 2.0 g/L oregano EO doses, while rosemary EO (2.0 g/L) reduced the methane production by 9%. The production of ammonia was significantly reduced (59%–78%) by all treatments with the exception of

rosemary EO at the lowest dose. Dry matter and neutral detergent fiber degradability was reduced by most of the treatments (respectively 4%–9% and 8%–24%). The total volatile fatty acids (VFA) concentration was markedly decreased by oregano EO and was not affected by rosemary EO. Both EOs mitigated rumen fermentations, but oregano EO gave rise to the highest reduction in methane and ammonia production. However, further research is needed to evaluate the use of these essential oils as dietary supplements by taking into account the negative effects on feed degradability.

Keywords: methane; ammonia; essential oil; oregano; rosemary; rumen; *in vitro* fermentation

1. Introduction

Agriculture produces about 10%–12% of the total global anthropogenic greenhouse gas (GHG) emissions: it contributes about 9% of the carbon dioxide (CO₂), 50% of the anthropogenic methane (CH₄) and 93% of the ammonia (NH₃) emissions [1]. Carbon dioxide gives the reference value of global warming potential (GWP) but is the most important GHG due to its high concentration in the atmosphere. The total CO₂ emissions from livestock production are related to indirect activities such as the transport of raw materials, feed production, fertilizers, pesticides and fossil fuel consumption for energy use. Carbon dioxide emissions from metabolic and respiratory activities are not considered in the total GHG amount because they are balanced by CO₂ captured by plants used for animal feeding. For this reason, animal respiratory activities are not considered to be a CO₂ source by the Kyoto Protocol.

Methane is characterized by a GWP of 25 times greater than that of CO₂ related to a period of 100 years [2]. Its concentration in the atmosphere is less than that of CO₂ but, due to its high GWP, methane is the second most responsible for global warming effects; however, methane may be used for supplying low environmental impact energy plants [3–5]. Livestock production is the second source of global methane emissions. Most of them derive from ruminant enteric fermentations, which are necessary for carbohydrate digestion (cellulose, hemicellulose, pectin and starch). Methane emitted by animals depends on many factors such as breed, production level, forage quality, feed intake, genetics and feed conversion efficiency. Ruminant animals produce significant amounts of CH₄ (33% of global CH₄ emissions) and contribute significantly to global warming through the emission of 4% of total GHG [6].

Livestock production and the related manure management are responsible for about 64% of total ammonia emissions from anthropic activities [2]. Ammonia is generated from the rapid degradation of urea in urine and feces; animal diet can influence its emission by modifying the metabolic efficiency of nitrogen. Ammonia emissions in the atmosphere are what is mainly responsible for acid rain. The effects of this phenomenon are the weakening of vegetation growth and the eutrophication of lakes and rivers.

Methane and NH₃ production represent not only an environmental hazard but also a loss of dietary energy and nitrogen that could potentially be redirected to milk and meat production [7,8]. Methane generation is achieved by archaea through the reduction of CO₂ with hydrogen that is produced by various ruminal bacteria during feed digestion. In contrast, the NH₃ production process mostly involves proteolytic bacteria and a group of bacteria called “hyper ammonia-producing bacteria” responsible of feed protein digestion and deamination of amino acids. The overproduction of ruminal

NH₃ causes large amounts of NH₃ and urea to be excreted with urine; it contributes to ground water pollution and GHG by nitrous oxide emission [9,10].

The complexity of rumen microbial ecosystems makes the manipulation of rumen microbial fermentations an important challenge for ruminant nutritionists. Several dietary strategies were suggested to mitigate CH₄ and NH₃ generation from ruminants without negatively affecting animal performance. For example, plant extracts such as essential oils (EOs) were widely evaluated as feed additives to improve rumen microbial metabolism, protein degradation, fermentation efficiency and to reduce CH₄ and NH₃ production.

The effects of essential oils (EOs) are due to their antimicrobial activity against ruminal microorganisms such as methanogenic archaea and hyper-ammonia producing bacteria. However, EOs also show adverse effects on fiber digestion. Despite an extensive evaluation in the last years, some aspects of the use of EOs in ruminant nutrition are still unknown. For example, EO composition in active compounds can be highly variable and can be influenced by factors such as plant species, stage of growth, parts of the used plant, soil composition, temperature, moisture stress and extraction method. Moreover, most of the literature reports only the most common commercial EOs tested with a limited range of treatments and low experimental doses.

EOs from Lamiaceae family herbs such as oregano (*Origanum vulgare* L.) and rosemary (*Rosmarinus officinalis* L.) are well known for their antioxidant, antimicrobial, and medicinal properties but only a few studies investigated their properties in mitigating rumen GHG production.

The aim of this study was to evaluate the effects of increasing doses of oregano and rosemary EOs on CH₄ and NH₃ production and fermentation characteristics by an *in vitro* system.

2. Experimental Section

2.1. Essential Oils

The oregano and rosemary EOs used in this study were purchased by Essential Srl (Montopoli Val d'Arno, Italy). EOs composition was analyzed by gas chromatography method. The analyses were performed by a Hewlett Packard HP 6890, combined with HP ChemStation Software, equipped with a flame ionization detector (FID) and a fused silica capillary column (HP-5MS; 30 m × 0.25 mm i.d., 0.25 µm film thickness). The oven temperature was programmed at 40 °C for 7 min, then ramped at 10 °C/min to 270 °C and held constant for 20 min. The injector and detector temperatures were respectively 250 °C and 270 °C. The samples were injected using the splitless mode; helium was used as carrier gas (1 mL/min). The samples were dissolved in hexane to give 0.125 µL/mL solutions; the injection volume was 1 µL. The percentage compositions of the oil components were obtained by FID electronic integration at 270 °C by dividing each component's area by the total area of all components. The percentage values were the mean of three sample injections.

2.2. In Vitro Fermentations

The ruminal inoculum for *in vitro* incubations was collected at a slaughterhouse from the rumen of three Chianina bulls fed with a ration composed of (dry-matter-basis percentage) corn silage (18.5%), mixed grass hay (13.4%), wheat straw (9.5%), wheat flour middlings (13.8%), barley meal (22.8%),

soybean meal (14.6%) and corn meal (7.4%). Rumen contents from each cow were strained through four layers of cheesecloth into a thermos leaving no headspace. The obtained fresh rumen fluid samples were immediately transported to the laboratory and combined in equal volume. The *in vitro* buffered medium [11] was anaerobically prepared by a continuous CO₂ flow as described in [12]. The rumen fluid was added to the buffered medium in a 1:2 proportion. The *in vitro* fermentations were carried out in 50 mL serum bottles in triplicate for each treatment including control. The solution and the serum bottles were continuously flushed with CO₂ and 20 mL of the medium was dispensed into each bottle containing 200 mg ground feed substrate. The feed substrate was composed of alfalfa hay and corn meal in a 1:1 ratio. Oregano and rosemary EOs were used at doses of 0, 0.5, 1.0, 1.5, 2.0 g/L (0 g/L is the control dose). The serum bottles were incubated at 39 °C for 24 h and subjected to continuous oscillation.

2.3. Sampling and Measurement

After a 24-hour incubation, gas pressure and gas composition (in terms of CO₂, CH₄, NH₃) were recorded by an ABE_1500 (A.B.Energy Srl, Cossato, Italy) infrared portable gas analyzer, currently used by a renewable energy power plant [13–17]. As well as the energy production plant monitoring, the infrared method for gas analyses was also used in previous lab scale experiments, which provided the evaluation of methane concentration due to rumen emissions [18,19].

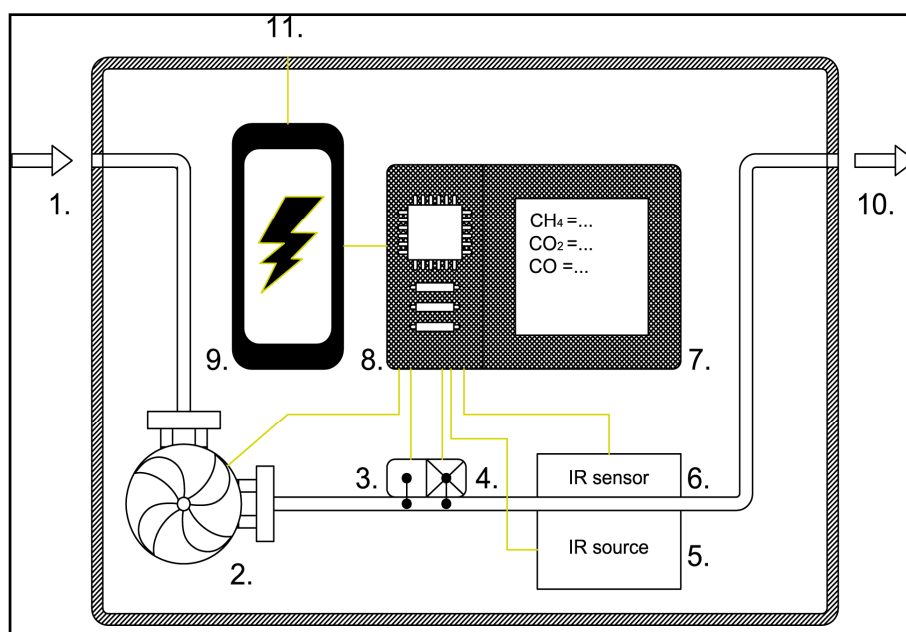

Figure 1. Flow diagram of ABE_1500 infrared analyzer. 1: Inlet gas connection; 2: Blower; 3: Anemometer; 4: Electrochemical sensor; 5: IR source; 6: IR sensor; 7: Display; 8: CPU; 9: Battery; 10: Outlet gas connection; 11: Electricity grid connection.

The analyzer uses an infrared (IR) detector and an electrochemical sensor. The first one is used to quantify CH₄, CO₂ and carbon monoxide (CO), which are characterized by high infrared absorption coefficients at low temperatures. The second one is used to quantify oxygen (O₂) by electrochemical cells (Figure 1). NH₃ and hydrogen sulfide (H₂S) cannot be quantified by a standard configuration and

an additional calibration of the electrochemical sensor is performed to trace these two compounds. The accuracy of the electrochemical and IR sensors is about 1.5%. All gas components are displayed together on a ¼ VGA LCD monitor (Table 1). The measurement range is 0%–100% volume for CH₄, 0–20,000 ppm for CO, 0%–25% volume for O₂. These characteristics and its lightness and practicality allowed use of the analyzer, typically suitable for on-site measurements, for gas detection in *in vitro* fermentation systems. The produced gas was vacuum sampled at the end of the fermentation phase by the instrument through a small plastic tube and a needle inserted into each bottle's rubber stopper.

Table 1. Range and accuracy of measurements performed by ABE_1500 gas analyzer.

Component	Operative Range	Accuracy
Oxygen detector	0%–25% Volume	+/-1%
Methane detector	0%–100% Volume	+/-1.5%
Carbon dioxide detector	0%–100% Volume	+/-1.5%
Carbon monoxide detector	0–20,000 ppm	+/-1.5%
Ammonia detector	0–1000 ppm	+/-3%
Hydrogen sulfide detector	0–500 ppm	+/-3%
Absolute pressure detector	100–1200 mbar	+/-2%
Differential pressure detector	-200–0 mbar	+/-2%
Temperature detector	-10–100 °C	0.5 °C
Flow detector	0.6–40 m/s	
Aspiration pump	0–2000 cm ³ /min	
Aspiration pump	+100/-450 mBar	

The content of each bottle was filtered through filter bags (Ankom Technology, Macedon, NY, USA; 50 µm pore size) to determine the degradability of residual feed substrate. The filtrates were sampled for the determination of volatile fatty acids (VFA) and stored at -80 °C before the analyses. VFA concentration, apparent dry matter (DM) degradability and neutral detergent fiber (NDF) degradability were determined as previously described by [20].

2.4. Statistical Analysis

Data on rumen fermentation characteristics were analyzed by SAS ANOVA procedure [21], which included EO type (oregano or rosemary) and dose level (0, 0.5, 1.0, 1.5 and 2.0 g/L) as fixed factors as well as their interaction. Differences between treatment means were determined by Tukey's test. Data were reported as least-squares means ± standard error. Differences were considered to be significant when $p \leq 0.05$.

3. Results and Discussion

3.1. Essential Oils

The composition of oregano and rosemary EOs is shown in Table 2. Sixteen compounds were identified in oregano EO. The composition of oregano EO was characterized by a high percentage (62.88%) of phenols such as *p*-cymene, thymol and carvacrol. The main compound was carvacrol (60.29%) which classified this EO as a carvacrol chemotype [22]. Rosemary EO contained 15 different

compounds. The main constituents were α -pinene (23.02%), camphor (21.86%) and 1,8-cineol (19.08%), which allows the classification of rosemary EO as a α -pinene/camphor chemotype [23].

Table 2. Oregano and rosemary EO composition.

Component	Oregano Essential Oil (%) ^{a,b}	Rosemary Essential Oil (%) ^{a,b}	RI ^{c,d}
α -Pinene	1.79 \pm 0.11	23.02 \pm 0.27	939
β -Pinene	0.26 \pm 0.22	5.65 \pm 0.15	979
Camphene	ND	9.90 \pm 0.59	954
Myrcene	2.14 \pm 0.19	1.64 \pm 0.12	989
3-Octanol	0.30 \pm 0.26	ND	998
Δ^3 -Carene	ND	0.92 \pm 0.06	1009
α -Terpinene	1.48 \pm 0.10	ND	1018
<i>p</i> -Cymene	1.77 \pm 0.41	0.20 \pm 0.10	1028
Limonene	ND	2.20 \pm 0.26	1029
β -Phellandrene	14.01 \pm 1.06	ND	1032
1,8-Cineol	0.80 \pm 0.69	19.08 \pm 0.35	1034
Linalool	1.58 \pm 0.23	1.07 \pm 0.07	1101
Camphor	ND	21.86 \pm 0.16	1144
Borneol	0.59 \pm 0.03	3.70 \pm 0.16	1153
γ -Terpinene	5.69 \pm 0.27	ND	1059
Terpinen-4-ol	0.32 \pm 0.28	ND	1169
α -Terpineol	ND	1.05 \pm 0.21	1189
Verbenone	ND	5.39 \pm 0.10	1207
Thymol	0.82 \pm 0.09	ND	1294
Bornyl acetate	ND	2.62 \pm 0.11	1295
Carvacrol	60.29 \pm 2.25	ND	1302
β -Caryophyllene	6.77 \pm 0.15	1.53 \pm 0.08	1295
Caryophyllene oxide	0.77 \pm 0.04	ND	1421
Total (%)	99.38	99.83	
Total identified	99.38	99.83	
Monoterpene hydrocarbons	27.14	43.53	
Oxygenated monoterpenes	64.40	54.77	
Sesquiterpene hydrocarbons	6.77	1.53	
Oxygenated sesquiterpenes	0.77		
Alcohols	0.30		

^a Percentage obtained by FID peak-area normalization. Values are presented as the mean \pm SD ($n = 3$);

^b Components are listed in order of their elution from a HP-5MS column; ^c Identification: by comparison of the mass spectrum with those of the NIST98 library computer (99% matching); ^d RI: Retention index, by comparison with those reported from NIST databank. Linear retention indices were determined relative to the retention times on HP-5MS columns of homologous series of C₅–C₂₀ alkanes by a Van den Dool and Krantz equation; ND: not detected.

3.2. In Vitro Fermentations

3.2.1. Effects on Gas Production and Feed Degradability

The effects of different doses of oregano and rosemary EOs on *in vitro* gas production and feed degradability are presented in Table 3. Total gas production decreased ($p < 0.001$) by about 6% and 9% respectively with the addition of 1.5 and 2.0 g/L oregano EO doses.

Table 3. Effects of increasing doses of oregano and rosemary EOs on *in vitro* total gas (mL), methane (mL), ammonia (ppm), carbon dioxide (mL) production and degradability (%) of feed substrate.

	Control	Oregano Essential Oil (g/L)				Rosemary Essential Oil (g/L)				SEM	<i>p</i> -Value		
		0.5	1.0	1.5	2.0	0.5	1.0	1.5	2.0		T	D	TxD
TG	30.62 ^a	30.63 ^a	30.59 ^a	28.90 ^b	27.94 ^c	30.65 ^a	30.63 ^a	30.63 ^a	30.61 ^a	0.13	<0.001	<0.001	<0.001
CH ₄	9.21 ^{a,b}	8.68 ^{b,c}	4.18 ^d	2.57 ^e	2.71 ^e	9.36 ^a	9.12 ^a	8.66 ^{b,c}	8.43 ^c	0.13	<0.001	<0.001	<0.001
NH ₃	1314.50 ^a	509.00 ^b	479.33 ^b	538.50 ^b	313.50 ^b	712.33 ^{a,b}	287.67 ^b	319.00 ^b	399.67 ^b	130.64	<0.01	0.270	0.314
CO ₂	20.35 ^a	20.53 ^a	13.25 ^b	6.75 ^c	4.63 ^c	19.53 ^a	19.76 ^a	20.05 ^a	19.95 ^a	0.66	<0.001	<0.001	<0.001
DMD	76.00 ^a	64.67 ^{b,c}	53.17 ^d	51.83 ^d	51.83 ^d	76.83 ^a	69.00 ^b	64.33 ^{b,c}	59.17 ^c	1.12	<0.001	<0.001	<0.05
NDFD	81.74 ^a	74.98 ^{b,c}	65.30 ^{d,e}	63.60 ^e	66.27 ^{d,e}	81.01 ^{a,b}	74.18 ^c	72.77 ^{c,d}	69.25 ^{c-e}	1.47	<0.001	<0.001	<0.05

SEM: standard error of the mean; TG: total gas; CH₄: methane; NH₃: ammonia; CO₂: carbon dioxide; DMD: dry matter degradability; NDFD: Neutral detergent fiber degradability; T: treatment; D: dose; TxD: treatment x dose; ^{a-c} Means with different letters within a same row differ significantly.

ANOVA revealed a significant ($p < 0.001$) interaction between treatment and dose: CH₄ and CO₂ productions were affected by 1.0, 1.5 and 2.0 g/L oregano EO doses (CH₄ reduction, in particular, ranged from 55% to 72%), while rosemary EO reduced CH₄ production only at the highest dose (−8.5%) and had no effect on CO₂ concentration. Several studies documented the effect of EOs in reducing *in vitro* CH₄ production through a direct inhibition of methanogenic archaea and/or an indirect depression of some microbial metabolic processes involved in methanogenesis [24]. Macheboeuf *et al.* [25] showed that CH₄ production was markedly inhibited for oregano EO doses of 0.45 and 0.75 g/L (respectively −63% and −97%). Roy *et al.* [26] obtained gas and CH₄ production reductions at a 0.6 g/L oregano EO level. In contrast, no effect on gas production was found by rosemary EO but a reduction in CH₄ production was observed for a 0.03 g/L level. EOs from garlic, cinnamon, eucalyptus, peppermint, juniper berry showed strong inhibitory activity on *in vitro* CH₄ production comparable to the one obtained by oregano EO in the present study [25,27–30]. At present, few *in vivo* studies were conducted to evaluate the effects of these compounds on CH₄ production. Some *in vivo* tests confirmed the potential of these plants and their extracts in CH₄ mitigation. Hristov *et al.* [31] demonstrated a CH₄ production reduction (−16.5, −11.7 and −13.6 g of methane per kg of DM intake) by three different doses of dietary oregano leaves (respectively 250, 500 and 750 g/animal per day) in dairy cows. Tekippe *et al.* [32] found similar results in dairy cows fed by oregano leaves at a 500 g/d rate (40% reduction in methane production).

All treatments, except for rosemary EO at the lowest dose (0.5 g/L), reduced NH₃ production ($p < 0.01$) in a dose-dependent manner (59%–78%), but DM and NDF degradability ($p < 0.001$) were reduced to the same extent (respectively 4%–9% and 8%–24%). The effects on DM and NDF degradability were more marked by the addition of oregano EO. Several works demonstrated that EOs can reduce NH₃ concentration and protein deamination by inhibiting hyper-ammonia producing bacteria [33]. Cardozo *et al.* [34] obtained a NH₃ concentration decrease using 0.03 and 0.3 g/L oregano extract doses. Another *in vitro* study showed the capability to decrease NH₃ production by 0.6 g/L oregano and rosemary EOs [26]. *In vitro* NH₃ concentration was also decreased by a combination of EOs composed of thyme, oregano, cinnamon and lemon applied at 0–0.5 g/L levels along with fumarate [35]. Lin *et al.* [36] observed a NH₃ inhibition with a mixture of EOs composed of clove, oregano, cinnamon and lemon in sheep (1 g/day). Contrasting results on *in vivo* NH₃ production were found by Hristov *et al.* [31] and Tekippe *et al.* [32] by feeding dairy cows with a supplementation of oregano leaves. However, as confirmed by the present study, the positive effects of EOs on CH₄ and NH₃ production are frequently associated to negative effects on feed digestibility, especially at the highest doses [28,37,38]. For example, Patra and Yu [30] observed a methane production reduction and a DM and NDF degradability decrease using a 1.0 g/L dose of EO from clove, eucalyptus, garlic, oregano and peppermint; the most pronounced effects were determined by oregano EO. The inhibition of feed digestion is due to the unselective antimicrobial activities of EOs that affect a wide range of microbial sub-populations such as, for instance, cellulolytic bacteria. In fact, Patra and Yu [30] found a decrease in the abundance of rumen archaea and protozoa but also in that of cellulolytic bacteria by all the tested EOs (clove, eucalyptus, garlic, oregano and peppermint). Most of EOs exhibit a wide range of antibacterial activity although Gram-positive bacteria are more sensitive than Gram-negative ones [39]. Small molecular weight compounds, such as carvacrol and thymol (major constituent of oregano and thyme EOs), have the ability to destroy the Gram-negative bacteria's additional

membranes by removing lipopolysaccharide membranes and increasing the permeability of cytoplasmic membranes [40]. For this reason, these compounds show an antibacterial activity stronger than the other EO compounds [40]. The abundance and activity of rumen fungi, protozoa and viruses can be also affected by EOs [33]. A novel study is here presented which consists of the original comparison between the effects of oregano and rosemary EOs with known terpene composition on *in vitro* rumen fermentations and feed degradability. The presented results should confirm that high levels of carvacrol in oregano EO composition are responsible of its marked antimicrobial activity.

3.2.2. Effects on Production of Volatile Fatty Acids

The increasing doses of oregano and rosemary EOs showed different effects on total VFA concentration and molar percentage of individual fatty acids (see Table 4). A significant ($p < 0.001$) interaction between treatment and dose was observed: total VFA concentration was markedly reduced by 1.0, 1.5 and 2.0 g/L oregano EO doses; it was not affected by the tested rosemary EO doses. The molar proportion of acetic acid was increased ($p < 0.001$) only by the highest rosemary EO doses (1.5 and 2.0 g/L). No difference was shown between treatments and control on molar proportion of propionic and n-valeric acids. In contrast, the concentration of butyric acid was increased by the two lowest oregano EO levels and reduced by the two highest rosemary EO levels ($p < 0.001$). Isobutyric acid and acetic/propionic acid ratios were affected ($p < 0.001$) by rosemary EO only at a 2.0 g/L level. The lowest isovaleric acid molar proportions were ($p < 0.001$) obtained by 1.5 and 2.0 g/L oregano EO doses and 2.0 g/L rosemary EO dose. The 2.0 g/L oregano EO dose determined high concentrations of capronic ($p < 0.01$) and heptanoic ($p < 0.05$) acids. As described in the literature, supplementation with EOs can cause contradictory effects on total VFA concentration [41]. Natural feed additives such as EOs can be considered useful in ruminant nutrition when they determine an increase of total VFA and propionic acid production and a decrease of the acetic/propionic acid ratio [40]. Several studies demonstrated that these compounds have a detrimental effect on the total VFA production along with a reduction of feed digestion, especially with high EO doses. High oregano EO doses seem to have a strong inhibition activity on rumen fermentation and consequently negative effects on VFA concentrations [25]. Busquet *et al.* [42] studied the effects of various plant extracts (anise, cade, capsicum, cinnamon, clove, bud, dill, fenugreek, garlic, ginger, oregano, tea tree and yucca) supplied at different doses on 24-hour *in vitro* ruminal fermentations. These authors observed that at the highest concentrations, most treatments decreased the total VFA production, as possible reflection of decreased feed digestion. Similar results were reported by Castillejos *et al.* [43]. Instead, Patra and Yu [30] found that VFA concentration was affected only by oregano and clove EOs while the supplementation of EOs in sheep diets did not show any effect on VFA production [20,36]. Some researchers showed that some EOs have positive effects on VFA molar proportions by decreasing the acetate production and increasing propionate production [44–46]. In accordance with the obtained results, many studies showed that the acetate/propionate ratio was increased [25,38,47] or not affected [29,48] by EOs. The effects of EOs on VFA production may depend on the ruminal fluid pH. Cardozo *et al.* [34] found that the effects of some EOs on rumen VFA profiles were more pronounced at low rumen pH; they suggested that pH is able to affect the dissociated or undissociated status of EO molecules.

Table 4. Effects of increasing doses of oregano and rosemary EOs on *in vitro* total VFA concentrations (mM) and molar percentage (%) of each fatty acid.

	Control	Oregano Essential Oil (g/L)				Rosemary Essential Oil (g/L)				SEM	<i>p</i> -Value		
		0.5	1	1.5	2	0.5	1	1.5	2		T	D	TxD
Total VFA	81.70 ^a	75.34 ^a	34.72 ^b	31.92 ^b	27.70 ^b	76.67 ^a	80.53 ^a	95.06 ^a	92.91 ^a	5.24	<0.001	<0.05	<0.001
Acetic (A)	63.06 ^{b-d}	61.61 ^d	62.75 ^{c,d}	64.95 ^{b,c}	63.86 ^{b-d}	63.19 ^{b-d}	62.97 ^{b-d}	65.61 ^b	68.56 ^a	0.56	<0.001	<0.001	<0.01
Propionic (P)	15.75 ^{a-c}	14.50 ^{b,c}	13.87 ^c	14.70 ^{b,c}	15.61 ^{a-c}	15.63 ^{a-c}	17.68 ^a	16.58 ^{a,b}	14.24 ^c	0.45	<0.001	0.250	<0.001
Butyric	15.80 ^b	18.06 ^a	17.98 ^a	15.28 ^{b,c}	15.27 ^{b-d}	15.76 ^{b,c}	13.87 ^{b-d}	13.30 ^d	13.80 ^{c,d}	0.42	<0.001	<0.001	<0.05
Isobutyric	1.06 ^{a,b}	1.07 ^{a,b}	1.23 ^{a,b}	1.28 ^{a,b}	1.40 ^a	1.11 ^{a,b}	1.01 ^{a,b}	0.86 ^b	0.48 ^c	0.09	<0.001	0.282	<0.001
<i>n</i> -valeric	1.65	1.69	1.79	1.68	1.40	1.65	1.57	1.06	0.96	0.21	0.143	0.110	0.610
Isovaleric	2.11 ^{a,b}	2.17 ^{a,b}	1.63 ^{b-d}	1.30 ^d	1.50 ^{c,d}	2.13 ^{a,b}	2.22 ^a	1.92 ^{a-c}	1.48 ^{c,d}	0.12	<0.001	<0.001	<0.05
Capronic	0.54 ^{b,c}	0.83 ^{a,b}	0.72 ^{a-c}	0.76 ^{a,b}	0.86 ^a	0.51 ^{b,c}	0.62 ^{a-c}	0.61 ^{a-c}	0.45 ^c	0.06	<0.01	0.983	0.117
Heptanoic	0.03 ^b	0.07 ^{a,b}	0.03 ^b	0.05 ^{a,b}	0.10 ^a	0.04 ^{a,b}	0.05 ^{a,b}	0.05 ^{a,b}	0.03 ^b	0.01	<0.05	0.503	0.051
A/P	4.00 ^{b,c}	4.28 ^{a,b,c}	4.53 ^{a,b}	4.42 ^{a,b}	4.09 ^{a-c}	4.05 ^{b,c}	3.58 ^c	3.96 ^{b,c}	4.82 ^a	0.15	<0.001	0.107	<0.001

VFA: Volatile fatty acids; SEM: standard error of the mean; T: treatment; D: dose; TxD: treatment x dose; ^{a-d} Means with different letters within a same row differ significantly.

4. Conclusions

The results of the proposed investigation showed that oregano EO, at the highest used concentrations, is a potent inhibitor of ruminal CH₄ and NH₃ production; it is probably due to the antimicrobial properties of carvacrol, its major compound. In contrast, rosemary EO showed limited effects on CH₄ mitigation but a strong inhibition activity on NH₃ production. Unfortunately, the most effective EO concentrations on GHG mitigation have also demonstrated adverse effects on feed degradability and VFA production as result of their marked and non-specific antimicrobial activity. Further research is needed to evaluate the use of oregano and rosemary EOs as dietary supplements by taking into account their unfavorable effects on feed degradability. Their biological activity depends on their composition and their composition is highly variable; thus, only a deep knowledge of EO nature, structure and purity can help to understand their favorable and/or unfavorable properties.

Acknowledgments

The authors would like to thank E. Cassetta for the support in laboratory analyses. This work is part of a Ph.D. research project in “Animal Health, Livestock Production and Food Safety,” University of Perugia, XXVIII cycle.

Author Contributions

Massimo Trabalza Marinucci is the coordinator of the Department of Veterinary Medicine group. Gabriele Acuti and Claudio Forte sampled the rumen fluid used as inoculum for the *in vitro* incubations performed by Gabriella Cobellis. The concentrations of volatile fatty acids in the cultures were analyzed by Mara Orrù. Maria Carla Marcotullio characterized the essential oils used in the study. Andrea Nicolini coordinated the CIRIAF group composed of Alessandro Petrozzi, Andrea Aquino and Valentina Mazza, for the gas content measurements by infrared instrument and data collection. Data were statistically evaluated by Massimo Trabalza Marinucci, Claudio Forte and Gabriella Cobellis. All authors have read and approved the final manuscript.

Conflicts of Interest

The authors declare no conflict of interest.

References

1. Lassen, J.; Løvendahl, P.; Madsen, J. Accuracy of noninvasive breath methane measurements using Fourier transform infrared methods on individual cows. *J. Dairy Sci.* **2012**, *95*, 890–898.
2. Cotana, F.; Petrozzi, A.; Pisello, A.L.; Cavalaglio, G.; Coccia, V.; Moretti, E. An innovative small sized anaerobic digester integrated in historic building. *Energy Procedia* **2013**, *45*, 333–341.
3. Rossi, F.; Nicolini, A. Experimental investigation on a novel electrolyte configuration for cylindrical molten carbonate fuel cells. *J. Fuel Cell Sci. Technol.* **2011**, *8*, doi:10.1115/1.4003773.
4. Rossi, F.; Nicolini, A. Ethanol reforming for supplying molten carbonate fuel cells. *Int. J. Low-Carbon Technol.* **2013**, *8*, 140–145.

5. Cotana, F.; Rossi, F.; Nicolini, A. A new geometry high performance small power MCFC. *J. Fuel Cell Sci. Technol.* **2004**, *1*, 25–29.
6. FAO. Greenhouse gas emissions from the dairy sector. In *A Life Cycle Assessment*; Food and Agriculture Organization of the United Nations: Rome, Italy, 2010.
7. FAO. Livestock's long shadow. In *Environmental Issues and Options*; Food and Agriculture Organization of the United Nations: Rome, Italy, 2006.
8. Eckard, R.J.; Grainger, C.; de Klein, C.A.M. Options for the abatement of methane and nitrous oxide from ruminant production: A review. *Livest. Sci.* **2010**, *130*, 47–56.
9. Weimer, P.J. Manipulating ruminal fermentation: A microbial ecological perspective. *J. Anim. Sci.* **1998**, *76*, 3114–3122.
10. Tedeschi, L.O.; Fox, D.G.; Tylutki, T.P. Potential environmental benefits of ionophores in ruminant diets. *J. Environ. Qual.* **2003**, *32*, 1591–1602.
11. Menke, K.H.; Steingass, H. Estimation of the energetic feed value obtained from chemical analysis and *in vitro* gas production using rumen fluid. *Anim. Res. Dev.* **1988**, *28*, 7–55.
12. Soliva, C.R.; Hess, H.D. Measuring methane emission of ruminants by *in vitro* and *in vivo* techniques. In *Measuring Methane Production from Ruminants*; Springer: Dordrecht, The Netherlands, 2007; pp. 15–31.
13. Cotana, F.; Coccia, V.; Petrozzi, A.; Cavalaglio, G.; Gelosia, M.; Merico, M.C. Energy valorization of poultry manure in a thermal power plant: Experimental campaign. *Energy Procedia* **2014**, *45*, 315–322.
14. Cotana, F.; Petrozzi, A.; Cavalaglio, G.; Coccia, V.; Pisello, A.L.; Bonamente, E. A batch digester plant for biogas production and energy enhancement of organic residues from collective activities. *Energy Procedia* **2014**, *61*, 1669–1672.
15. Cotana, F.; Messineo, A.; Petrozzi, A.; Coccia, V.; Cavalaglio, G.; Aquino, A. Comparison of ORC Turbine and Stirling Engine to Produce Electricity from Gasified Poultry Waste. *Sustainability* **2014**, *6*, 5714–5729.
16. Gugliermetti, F.; Dell’Omo, P.P. A theoretical and experimental approach to heat transfer from high temperature gas flowing inside nonhomogeneous rectangular pipes. *Revue. Gen. Therm.* **1998**, *37*, 531–538.
17. Salata, F.; Coppi, M. A first approach study on the desalination of sea water using heat transformers powered by solar ponds. *Appl. Energy* **2014**, *136*, 611–618.
18. Huhtanen, P.; Cabezas-Garcia, E.H.; Utsumi, S.; Zimmerman, S. Comparison of methods to determine methane emissions from dairy cows in farm conditions. *J. Dairy Sci.* **2015**, *98*, 1–16.
19. Pinares-Patiño, C.S.; McEwan, J.C.; Dodds, K.G.; Cárdenas, E.A.; Hegarty, R.S.; Koolaard, J.P.; Clark, H. Repeatability of methane emissions from sheep. *Anim. Feed Sci. Technol.* **2011**, *166–167*, 210–218.
20. Cobellis, G.; Acuti, G.; Forte, C.; Menghini, L.; de Vincenzi, S.; Orrù, M.; Valiani, A.; Pacetti, D.; Trabalza-Marinucci, M. Use of *Rosmarinus officinalis* in sheep diet formulations: Effects on ruminal fermentation, microbial numbers and *in situ* degradability. *Small Rumin. Res.* **2015**, *126*, 10–18.
21. SAS Institute Inc. *JMP® 9 Basic Analysis and Graphing*; SAS Institute Inc.: Cary, NC, USA, 2010.

22. Fleisher, A.; Sneer, N. Oregano spices and *Origanum* chemotypes. *J. Sci. Food Agric.* **1982**, *33*, 441–446.
23. Matsuzaki, Y.; Tsujisawa, T.; Nishihara, T.; Nakamura, M.; Kakinoki, Y. Antifungal activity of chemotype essential oils from rosemary against *Candida albicans*. *Open J. Stomatol.* **2013**, *3*, 176–182.
24. Knapp, J.R.; Laur, G.L.; Vadas, P.A.; Weiss, W.P.; Tricarico, J.M. Invited review: Enteric methane in dairy cattle production: Quantifying the opportunities and impact of reducing emissions. *J. Dairy Sci.* **2014**, *97*, 3231–3261.
25. Macheboeuf, D.; Morgavi, D.P.; Papon, Y.; Mousset, J.L.; Arturo-Schaan, M. Dose-response effects of essential oils on *in vitro* fermentation activity of the rumen microbial population. *Anim. Feed Sci. Technol.* **2008**, *145*, 335–350.
26. Roy, D.; Tomar, S.K.; Sirohi, S.K.; Kumar, V.; Kumar, M. Efficacy of different essential oils in modulating rumen fermentation *in vitro* using buffalo rumen liquor. *Vet. World* **2014**, *7*, 213–218.
27. Chaves, A.V.; Stanford, K.; Dugan, M.E.R.; Gibson, L.L.; McAllister, T.A.; van Herk, F.; Benchaar, C. Effects of cinnamaldehyde, garlic and juniper berry essential oils on rumen fermentation, blood metabolites, growth performance, and carcass characteristics of growing lambs. *Livest. Sci.* **2008**, *117*, 215–224.
28. Agarwal, N.; Shekhar, C.; Kumar, R.; Chaudhary, L.C.; Kamra, D.N. Effect of peppermint (*Mentha piperita*) oil on *in vitro* methanogenesis and fermentation of feed with buffalo rumen liquor. *Anim. Feed Sci. Technol.* **2009**, *148*, 321–327.
29. Kumar, R.; Kamra, D.N.; Agarwal, N.; Chaudhary, L.C. Effect of eucalyptus (*Eucalyptus globulus*) oil on *in vitro* methanogenesis and fermentation of feed with buffalo rumen liquor. *Anim. Feed Sci. Technol.* **2009**, *9*, 237–243.
30. Patra, A.K.; Yu, Z. Effects of essential oils on methane production and fermentation by, and abundance and diversity of, rumen microbial populations. *Appl. Environ. Microbiol.* **2012**, *78*, 4271–4280.
31. Hristov, A.N.; Lee, C.; Cassidy, T.; Heyler, K.; Tekippe, J.A.; Varga, G.A.; Cori, B.; Brandt, R.C. Effect of *Origanum vulgare* L. leaves on rumen fermentation, production, and milk fatty acid composition in lactating dairy cows. *J. Dairy Sci.* **2013**, *96*, 1189–1202.
32. Tekippe, J.A.; Hristov, A.N.; Heyler, K.S.; Cassidy, T.W.; Zheljaskov, V.D.; Ferreira, J.F.S.; Karnati, S.K.; Varga, G.A. Rumen fermentation and production effects of *Origanum vulgare* L. leaves in lactating dairy cows. *J. Dairy Sci.* **2011**, *94*, 5065–5079.
33. Patra, A.K. Effects of essential oils on rumen fermentation, microbial ecology and ruminant production. *Asian J. Anim. Vet. Adv.* **2011**, *6*, 416–428.
34. Cardozo, P.W.; Calsamiglia, S.; Ferret, A.; Kamel, C. Screening for the effects of natural plant extracts at different pH on *in vitro* rumen microbial fermentation of a high-concentrate diet for beef cattle. *J. Anim. Sci.* **2005**, *83*, 2572–2579.
35. Lin, B.; Lu, Y.; Wang, J.H.; Liang, Q.; Liu, J.X. The effects of combined essential oils along with fumarate on rumen fermentation and methane production *in vitro*. *J. Anim. Feed Sci.* **2012**, *21*, 198–210.

36. Lin, B.; Lu, Y.; Salem, A.Z.M.; Wang, J.H.; Liang, Q.; Liu, J.X. Effects of essential oil combinations on sheep ruminal fermentation and digestibility of a diet with fumarate included. *Anim. Feed Sci. Technol.* **2013**, *184*, 24–32.
37. Busquet, M.; Calsamiglia, S.; Ferret, A.; Carro, M.D.; Kamel, C. Effect of garlic oil and four of its compounds on rumen microbial fermentation. *J. Dairy Sci.* **2005**, *88*, 4393–4404.
38. Patra, A.K.; Kamra, D.N.; Agarwal, N. Effect of plants containing secondary metabolites on *in vitro* methanogenesis, enzyme profile and fermentation of feed with rumen liquor of buffalo. *Anim. Nutr. Feed Technol.* **2006**, *6*, 203–213.
39. Szumacher-Strabel, M.; Cieslak, A. Dietary possibilities to mitigate rumen methane and ammonia production. In *Greenhouse Gases—Capturing, Utilization and Reduction*; Intech: Rijeka, Croatia, 2012.
40. Calsamiglia, S.; Busquet, M.; Cardozo, P.W.; Castillejos, L.; Ferret, A. Invited review: Essential oils as modifiers of rumen microbial fermentation. *J. Dairy Sci.* **2007**, *90*, 2580–2595.
41. Benchaar, C.; Calsamiglia, S.; Chaves, A.V.; Fraser, G.R.; Colombatto, D.; McAllister, T.A.; Beauchemin, K.A. A review of plant-derived essential oils in ruminant nutrition and production. *Anim. Feed Sci. Technol.* **2008**, *145*, 209–228.
42. Busquet, M.; Calsamiglia, S.; Ferret, A.; Kamel, C. Plant extracts affect *in vitro* rumen microbial fermentation. *J. Dairy Sci.* **2006**, *89*, 761–771.
43. Castillejos, L.; Calsamiglia, S.; Ferret, A. Effect of essential oils active compounds on rumen microbial fermentation and nutrient flow *in vitro* systems. *J. Dairy Sci.* **2006**, *89*, 2649–2658.
44. McGuffey, R.K.; Richardson, L.F.; Wilkinson, J.I.D. Ionophores for dairy cattle: Current status and future outlook. *J. Dairy Sci.* **2001**, *84*, 194–203.
45. Mohammed, N.; Ajisaka, N.; Lila, Z.A.; Mikuni, K.; Hara, K.; Kanda, S.; Itabashi, H. Effect of Japanese horseradish oil on methane production and ruminal fermentation *in vitro* and in steers. *J. Anim. Sci.* **2004**, *82*, 1839–1846.
46. Busquet, M.; Calsamiglia, S.; Ferret, A.; Cardozo, P.W.; Kamel, C. Effects of cinnamaldehyde and garlic oil on rumen microbial fermentation in a dual flow continuous culture. *J. Dairy Sci.* **2005**, *88*, 2508–2516.
47. Benchaar, C.; Petit, H.V.; Berthiaume, R.; Ouellet, D.R.; Chiquette, J.; Chouinard, P.Y. Effects of essential oils on digestion, ruminal fermentation, rumen microbial populations, milk production, and milk composition in dairy cows fed alfalfa silage or corn silage. *J. Dairy Sci.* **2007**, *90*, 886–897.
48. Wang, C.J.; Wang, S.P.; Zhou, H. Influences of flavomycin, ropadiar, and saponin on nutrient digestibility, rumen fermentation, and methane emission from sheep. *Anim. Feed Sci. Technol.* **2009**, *148*, 157–166.