

Electrical engineering on stage: when digital design meets dance

David M. Beams, Jennifer Bailey

Department of Electrical Engineering, University of Texas at Tyler/
Tyler Junior College Academy of Dance

Making the general public aware of the contributions of engineers to their lives is a continuing task. The engineering program of the University of Texas at Tyler has found a unique way to enhance its visibility with a segment of the public that ordinarily takes little notice of engineering. The College of Engineering and Computer Science has developed stage props for the annual production of *The Nutcracker* by the Department of Dance of Tyler Junior College. Two props are involved in the 2004 production: a self-propelled electrically-driven sleigh (used to transport Clara and the Nutcracker to the Land of the Sweets) and a microcontroller-based grandfather clock used during the Christmas party scene and the battle between the toy soldiers and mice. This relationship has provided projects (both for senior design and independent study) to engineering students while exposing them to a segment of the performing arts; conversely, it has exposed persons in the arts community to engineering. The development and use of these stage props are described in this paper, as well as how they have earned favorable publicity for the College of Engineering.

A brief history of an unlikely collaboration

Tyler Junior College (TJC) is a two-year community college that was established in Tyler, Texas, in 1926. Among its programs is the TJC Academy of Dance which offers classes to the community in varied styles of dance including ballet, modern, tap, and jazz. The Academy of Dance has staged annual productions of *The Nutcracker* since 1989.

The University of Texas at Tyler (UT-T) was established as Tyler State College in 1973 as an upper-division school. It was incorporated into the University of Texas system in 1979 and became a four-year undergraduate institution in 1998. The engineering program was founded in 1997 with programs in electrical engineering and mechanical engineering. The present College of Engineering and Computer Science (CECS) was formed in 2001 when the Department of Computer Science and the College of Engineering were joined as part of a University-wide reorganization.

E. T. A. Hoffman's story *The Nutcracker and the Mouse King* dates to the early 19th century; Tchaikovsky's *Nutcracker Suite* was first performed in 1892 in St. Petersburg, Russia. *The Nutcracker* has become a Christmas tradition in the United States since its staging by George Balanchine and the New York City Ballet in 1954. While *The Nutcracker* is founded upon a long-standing tradition, audiences who attend regularly need to see something new each year.

Ballet is an art form in which a story is told through movement, pantomime, and special effects. Special effects must catch the audience's eye while complementing the other forms.

The first connection between TJC's production of *The Nutcracker* and UT-T's College of Engineering was established in the fall of 2000 when a member of the UT-T electrical engineering faculty was recruited by his daughter (who was already a member of the cast of *The Nutcracker*) because the artistic director was "desperate for men for the party scene." (Recruitment of adult men for the opening Christmas party scene is often a challenge).

The production of 2000 introduced a "magic" sleigh to transport Clara and the Nutcracker Prince to the Land of the Sweets. The actual sleigh was less than magic; its heavy plywood sides were attached to a wooden platform that rolled on casters. The motive force was supplied by a stagehand hidden from view of the audience by a black curtain covering the back end of the sleigh. Unfortunately, the stagehand was sometimes partially visible to the audience from certain angles, detracting from the sense of magic and wonder. The cast member playing the role of Uncle Drosselmeyer made the suggestion to "motorize" the sleigh for the next year's performance. The EE faculty member proposed this to a student as his senior project in the spring of 2001, and the Dean of the College authorized funding. The completed design was used on-stage in December, 2001. Figure 1 shows the sleigh on-stage in the 2002 production. (The plywood sides were replaced prior to the 2001 production with new sides of dense polystyrene foam in the shape of swans, making them both lighter and much more aesthetically pleasing).



Fig. 1. Sleigh being driven on stage in the 2002 production of *The Nutcracker*.

A plywood grandfather clock had been used in the Christmas party scene for a number of years. It was a static prop, however; its hands did not move. It was incongruous to the audience that the Christmas party scene should end at the same time at which it began. A project to make the clock keep accelerated time during the Christmas party scene and to implement other special timing effects was undertaken in 2004 as an independent study project for two EE seniors who were allowed to use it as a 3-credit technical elective. The clock was used for the first time in the 2004 production. Figure 2 shows the completed clock.



Fig. 2. The grandfather clock on stage after a performance in the 2004 production.

Design and realization of the sleigh

Ballet imposes aesthetic as well as technical constraints on the solution space of special effects. The following aesthetic and technical requirements were factors in the design of the sleigh:

- The design had to be "magic;" no means of propulsion or steering could be visible to the audience.
- The propulsion system could not make noise perceptible to the audience.

- The design had to be inherently safe; no electronic failure could be permitted to cause injury or runaway operation.
- The design had to be simple to learn to operate.
- The propulsion system was required to achieve a maximal forward speed of 2 mi/hr (3.2 km/hr) while transporting an estimated weight of vehicle and passengers of 350 lb (1560 N). This speed requirement was developed from the expected distance the sleigh would have to travel during musical passages during which the sleigh was to be on stage. The limited dimensions of the stage required a high degree of maneuverability; a short turning radius was essential, and the ability to turn in place was desirable.

The evident design choice for this application was to propel the sleigh with two independent permanent-magnet dc motors. Tests on stage with the sleigh established the thrust requirements; motor speed and torque requirements were then fixed once the diameter of the drive wheels was established.

Figure 3 shows the motorization scheme in block-diagram form.

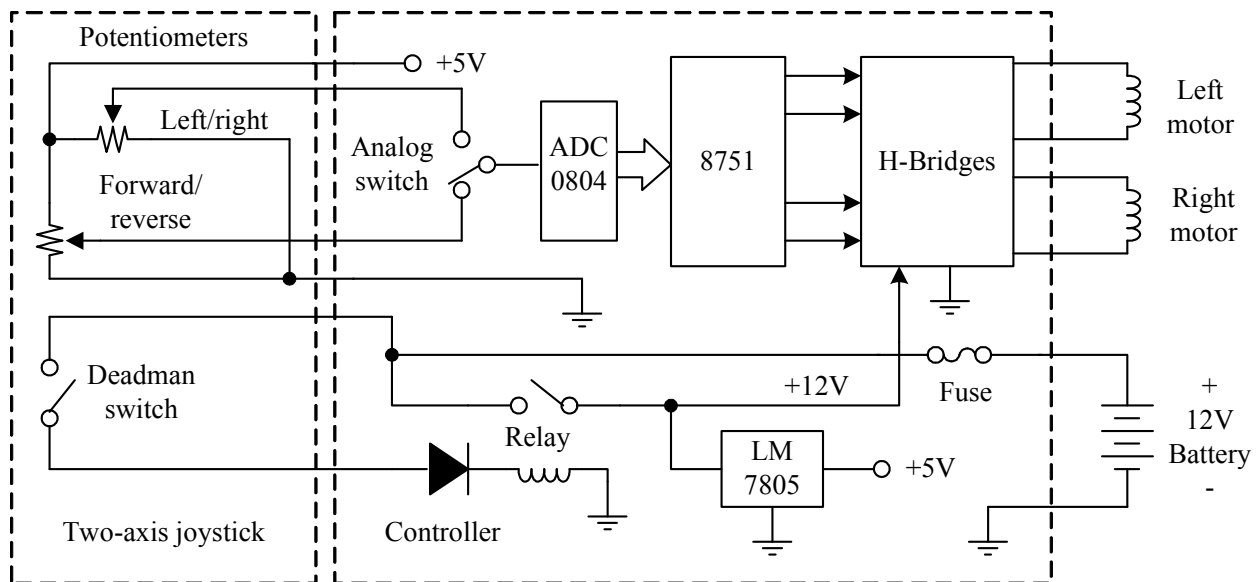

Fig. 3. Block diagram representation of the motorization of the *Nutcracker* sleigh.

Two permanent-magnet dc motors (Groschopp PM80141920) with 20:1 reducing gearheads (Groschopp PS1900) were chosen for propulsion. A two-axis potentiometer joystick was selected as the controller element. It includes a pushbutton switch that serves as a "deadman" switch. Pressing the switch engages a relay that applies power to the controller and motors; releasing it removes power. This satisfies the safety requirement. A diode in series with the deadman switch prevents engagement of the relay if the battery polarity is reversed, thus preventing damage to the controller if the battery is installed backward. The joystick lever is also sufficiently small that a passenger can hide it with one hand, making the joystick invisible to the audience. Potentiometer positions represented by analog voltages are read by an ADC0804 8-bit successive-approximation analog-to-digital converter. An 8751 microcontroller converts the digitized joystick positions to pulses of varying widths with a repetition rate of approximately

200 Hz. These pulses actuate H-bridge drivers (consisting of n- and p-channel MOSFETs) to control the flow of power to the motors. Electrical power is obtained from a 12V battery of the type used in lawn and garden tractors. Code for the 8751 was developed in 8051 assembly language with the Kiel MicroVision 2 development tools.

Design and realization of the grandfather clock

The design of the grandfather clock included the following requirements:

- The clock had to be capable of multiple modes of operation which were to be defined in connection with the choreography. The chosen modes were:
 1. Homing: upon power-up or reset, the clock hands move to 4:00.
 2. Mode 0 (standby): the clock hands do not move and the backlights of the clock are OFF.
 3. Mode 1 (standby with lights): the clock hands do not move and the backlights are ON at half-power.
 4. Mode 2 (normal timekeeping): the clock advances to 8:00 and begins keeping time at 9× real time; backlights are ON at full power.
 5. Mode 3 ("crazy" mode): the hour hand revolves once per second, and the minute hand revolves the opposite direction at half that rate; backlights flash between half-power and full power at 2 Hz.
 6. Mode 4 (midnight): the hands move to 12:00 and stop; backlights are ON at full power.
- The clock had to be controlled by the technical crew operating the light and sound control boards.
- The clock was to be realized with a printed-circuit board and be fully documented (schematic, circuit board artwork, parts list, commented code listing).

The principal design challenge of the clock was finding a method of controlling it from the light board. Several ideas were discussed and discarded before a scheme was devised in which the clock was powered from a standard 120VAC source but was controlled through a separate spotlight outlet. The spotlight outlets on stage are triac-based lamp dimmers; measurement of the duty cycle of the chopped waveform at the spotlight outlet was used to control the clock mode.

Figure 4 shows a block diagram of the clock design.

The hands of the clock are driven by bipolar stepper motors with 3.6° per step. Integrated dual H-bridge drivers (L298N) drive the windings of the stepper motors. Home position of the hands is determined by slotted disks and GP1S58V photointerrupters.

The spotlight voltage is converted to a train of logic-level rectangular pulses by a bridge rectifier and a 4N25 optical isolator. The average value of this pulse train is extracted by a passive RC low-pass filter and digitized by an ADC0804 successive-approximation analog-to-digital converter. The digital output of the ADC0804 is read by the AT89C51 CMOS microcontroller to determine the mode of operation.

The backlight lamps are controlled through a 2N6071 triac which is triggered by the microcontroller through an MOC 3011 optical triac isolator. Full-power operation of the lamps is accomplished by holding the controlling pin of the microcontroller at a logic 0 value. A logic 1 value on this pin turns off the lamps.

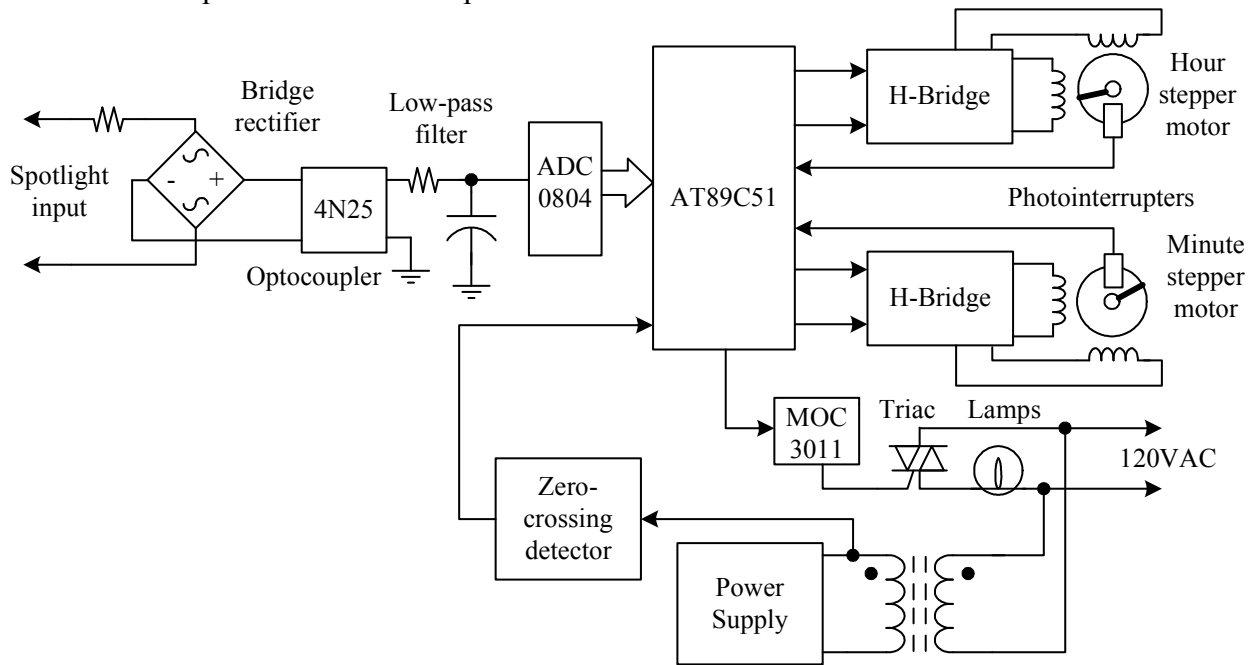

Fig. 4. Block diagram of the microprocessor-controlled grandfather clock

Half-power operation is somewhat more complex. A zero-crossing detector circuit provides external interrupts synchronous with zero crossings of the ac power line. When half-power operation is called for, the external interrupt routine sets up a timer interrupt to expire in 4.16 ms. The microcontroller pin is briefly driven to a logic 0 when the timer interrupt occurs, triggering the triac and applying line voltage to the lamps. The microcontroller pin is returned to a logic 1 before the next zero crossing to ensure that unintentional retriggering of the triac will not occur.

Code for the AT89C51 was developed in 8051 assembly language with the Kiel MicroVision 2 development tools.

The mechanical design of the clock involved coaxial shafts made of thin-walled aluminum tubing. The inner shaft (coupled to the hour hand) was driven directly from the shaft of one stepper motor; the outer shaft was driven from the other stepper motor by an arrangement of two sprockets connected by a plastic chain.

Benefits to electrical engineering students—the project developers

The two senior EE students who committed to this project were presented with a project involving real engineering constraints and considerations:

- The schedule was immutable. The clock had to be ready by no later than Nov. 29, 2004, in order for it to be used in rehearsals in production week. A slippage of even one week meant failure of the project.
- Software development and hardware development had to proceed in concert.
- Accurate documentation was vital. This lesson was particularly reinforced in the construction and test of the printed circuit board when improper stepping of the stepper motors was eventually traced to mislabeled connections on the schematic diagram. Accurate documentation was also indispensable to maintainability of the clock.
- Construction had to be robust; a one-of-a-kind, hand-built prototype was unacceptable.

Benefits to electrical engineering students—the *Nutcracker* technical presentation

The 2004 production marked the second time that students in EENG 3306 (Electronic Circuit Analysis I) have been offered extra credit for attending the ballet and coming backstage after the performance for a 20-minute presentation on the design and operation of the electronics. Figure 5 is a photograph taken during the 2004 presentation.



Fig. 5. Explanation of the operation of the clock (removed from the cabinet) at the backstage technical presentation.

The students who attended the ballet and the backstage presentation were surveyed about their experiences. Their responses can be summarized as follows:

- All students reported that the technical presentation was educational. Most respondents commented that they could see concrete, practical uses for devices and circuits that had been presented in class.
- Four of eleven respondents said that the experience enhanced their appreciation for ballet.

- Five of eleven respondents had never attended a ballet before the 2004 production of *The Nutcracker*. (Two other respondents said they had only been exposed to ballet through previous productions of *The Nutcracker*).

Participants in the technical presentation gained some technical insight from the backstage presentation, and some were given their first exposure to the art of ballet.

Benefits to the audience and performers

Special effects should catch the eye of the audience, but they also catch the eye of the performer. The sleigh and the many functions of the clock made the ballet seem more realistic and yet more magical to the audience and the performers alike.

The clock's keeping time during the Christmas party made the audience feel as though they were attending the party as well. The use of the clock and its functions helped to tell the story, and children to adults could appreciate the use of the clock throughout the first act of the ballet. For example, the choreography called for the magical Uncle Drosselmeyer to appear as an unexpected guest at the Christmas party. His otherwise unseen arrival was announced by an abrupt break in the music at which all party guests (except Clara) were instantly frozen in place. The clock was thrown into "crazy" mode for the duration of the freeze, emphasizing the suspension of normal rules of space and time as Drosselmeyer wove a spell and as Clara frantically rushed from one immobilized party guest to the next. Drosselmeyer then retreated into the shadows; the "freeze" ended as abruptly as it began, and the clock returned to its last normal time and resumed timekeeping as if nothing had happened. The clock was later thrown into "midnight" mode just as Clara's dream began and into "crazy" mode during the battle between the toy soldiers and the mice, again emphasizing that space and time had been thrown into disarray.

The appearance of the sleigh in the forest scene that concludes Act I emphasized the magical nature of that scene. The sleigh's reappearance in the Land of the Sweets in Act II emphasized that Clara and the Prince had arrived at the end of a long journey.

The dance students benefited greatly from this collaboration between TJC and UT-T. They learned how a well-rounded theater experience can capture an audience. Along with the performing experience the students saw the technical aspects and workings of special effects. Rehearsing and perfecting choreography is always a work in progress as well as making the special effects seem effortless and realistic. The dance students now have a true appreciation of the technical aspects as well as the performing aspects of a production.

The artistic vision for the *Nutcracker* has to be magical, but realistic. The clock and sleigh served both purposes. The performers, the special effects, and an experienced backstage technical crew are the elements that bring the magic of the theater to life.

Benefits to the College of Engineering and Computer Science

One of the preeminent benefits of this collaboration has been the favorable publicity earned for the College of Engineering and Computer Science, especially among a section of the population that may have been unaware of the College's existence or mission. The story of the development of the sleigh was the featured story in the Entertainment section of the Tyler Telegraph (the local daily newspaper) on Dec. 7, 2001 (which coincided with opening night of the performance). The 2004 program included the acknowledgement page reproduced in Fig. 6 below.

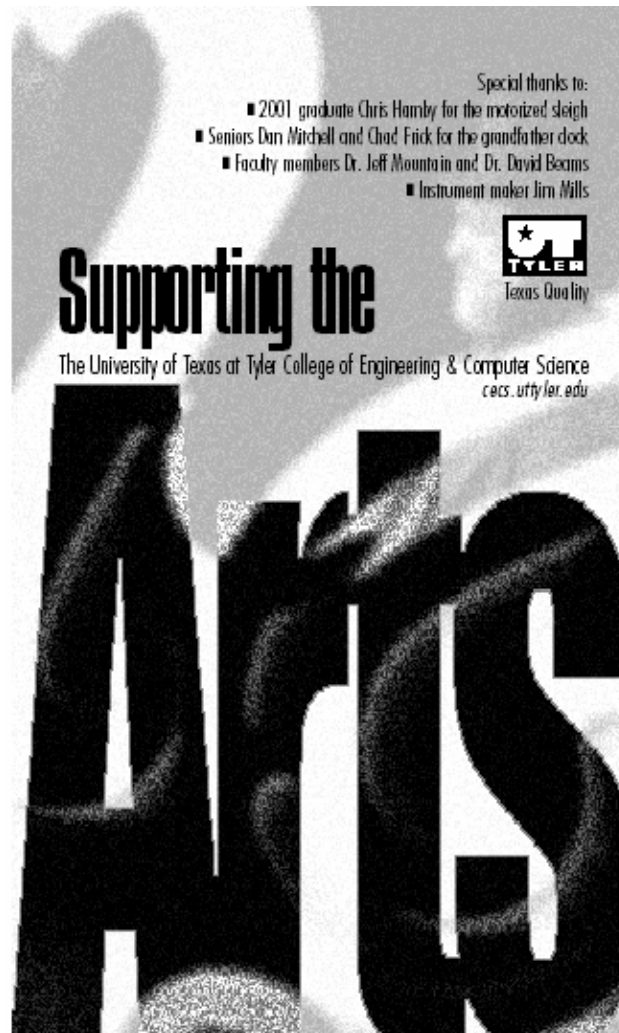

Fig. 6. Acknowledgement page from the program of the 2004 production of *The Nutcracker*. The stylized image is that of the sleigh being driven by the cast member playing Uncle Drosselmeyer.

Conclusion

An unusual collaboration between the Academy of Dance of Tyler Junior College and the College of Engineering and Computer Science (CECS) of the University of Texas at Tyler has provided engineering students with project opportunities involving realistic constraints and has allowed their work to be demonstrated publicly before large audiences. It has also provided favorable publicity for CECS, increased the exposure of engineering students to the performing

arts, and given dancers and performers a new appreciation for the technical side of theatrical production.

DAVID M. BEAMS is an Associate Professor of Electrical Engineering at the University of Texas at Tyler. He received his BS and MS degrees from the University of Illinois at Urbana-Champaign in and the Ph.D. from the University of Wisconsin-Madison. He has had over 16 years of industrial experience in addition to his 8 years with UT-Tyler. He is a licensed professional engineer in Wisconsin and Texas and holds or shares four patents.

JENNIFER BAILEY is the Interim Director of the Academy of Dance of Tyler Junior College. She earned a BA in Dance from LaRoche College (Pittsburgh, PA) in 2001 and joined Tyler Junior College in 2002. She is a certified instructor in Cecchetti method (Levels I and II) and ballroom dance.