

Lawrence Berkeley National Laboratory

Recent Work

Title

Thermally Efficient Compact Fluorescent Fixture Systems

Permalink

<https://escholarship.org/uc/item/7268j5wx>

Authors

Siminovitch, M.J.
Rubinstein, Francis M.
Packer, M.

Publication Date

1991-04-01



Lawrence Berkeley Laboratory

UNIVERSITY OF CALIFORNIA

APPLIED SCIENCE DIVISION

Presented at the IEA/ENEL Conference on Advanced Technologies for Electric Demand-Side Management, Sorrento, Italy, April 2-5, 1991, and to be published in the Proceedings

Thermally Efficient Compact Fluorescent Fixture Systems

M.J. Siminovitch, F.M. Rubinstein, and M. Packer

April 1991

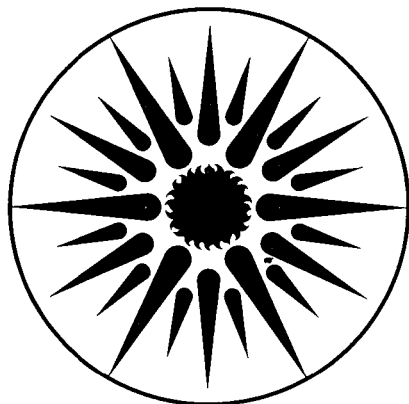

APPLIED SCIENCE
DIVISION

DISCLAIMER

This document was prepared as an account of work sponsored by the United States Government. While this document is believed to contain correct information, neither the United States Government nor any agency thereof, nor the Regents of the University of California, nor any of their employees, makes any warranty, express or implied, or assumes any legal responsibility for the accuracy, completeness, or usefulness of any information, apparatus, product, or process disclosed, or represents that its use would not infringe privately owned rights. Reference herein to any specific commercial product, process, or service by its trade name, trademark, manufacturer, or otherwise, does not necessarily constitute or imply its endorsement, recommendation, or favoring by the United States Government or any agency thereof, or the Regents of the University of California. The views and opinions of authors expressed herein do not necessarily state or reflect those of the United States Government or any agency thereof or the Regents of the University of California.

*Presented at the IEA/ENEL Conference on Advanced
Technologies for Electric Demand-Side Management
Sorrento, Italy, 2-5 April 1991.*

LBL-30180
L-150

THERMALLY EFFICIENT COMPACT FLUORESCENT FIXTURE SYSTEMS

Michael J. Siminovitch, Francis M. Rubinstein and Michael Packer

Lighting Systems Research Group
Applied Science Division
Lawrence Berkeley Laboratory
Berkeley, California 94720, United States

April 1991

This work was supported by the Assistant Secretary for Conservation and Renewable Energy, Office of Building Technologies, Building Equipment Division of the U.S. Department of Energy under Contract No. DE-ACO3-76SF00098.

THERMALLY EFFICIENT COMPACT FLUORESCENT FIXTURES SYSTEMS

Michael J. Siminovitch, Francis M. Rubinstein and Michael Packer

Lighting Systems Research Group
Applied Science Division
Lawrence Berkeley Laboratory
Berkeley, California 94720, United States

ABSTRACT

Compact fluorescent lamps that can be inserted into conventional light fixtures are rapidly gaining acceptance as both a viable retrofit and new design approach to reducing lighting loads. Ideally, the compact fluorescent lamp should have the same light output as the incandescent lamp it replaces, but overheating inside typically small enclosed fixtures can reduce lumen output and hence lighting fixture efficiency by 15 to 20 percent. Fortunately, simple fixture modifications can erase this efficiency penalty, so that the full efficiency benefit of replacing incandescent lamps with fluorescent lamps can be realized. The paper describes such modifications and presents experimental data documenting the potential efficiency enhancement associated with thermal control systems.

INTRODUCTION

Compact fluorescent lamp fixture systems are seeing increased usage in both retrofit and new construction applications. The primary motivation for substituting compact fluorescent for incandescent is the higher efficacy of the compact lamp. A second driver for compact fluorescent lamps is the reduction in maintenance costs that result from longer lamp life.

A major problem with the operation of compact fluorescent lamps inside small fixtures is their tendency to lose both light output and efficacy as a function of higher ambient temperatures and corresponding minimum lamp wall temperatures (MLWT). This occurs as fluorescent lamps are highly temperature sensitive, as their performance is dependent on the coldest temperature on the lamp wall which controls the mercury vapor pressure and thus the light output and efficacy characteristics. Experimental studies have indicated that compact fluorescent lamps achieve maximum efficacy and lumen output at minimum lamp wall temperatures of approximately 40C° (approximately 25C° ambient temperature). Figure 1 shows light output and efficacy for a core-coil ballasted, horizontally burning 26 watt compact fluorescent lamp as a function of MLWT.

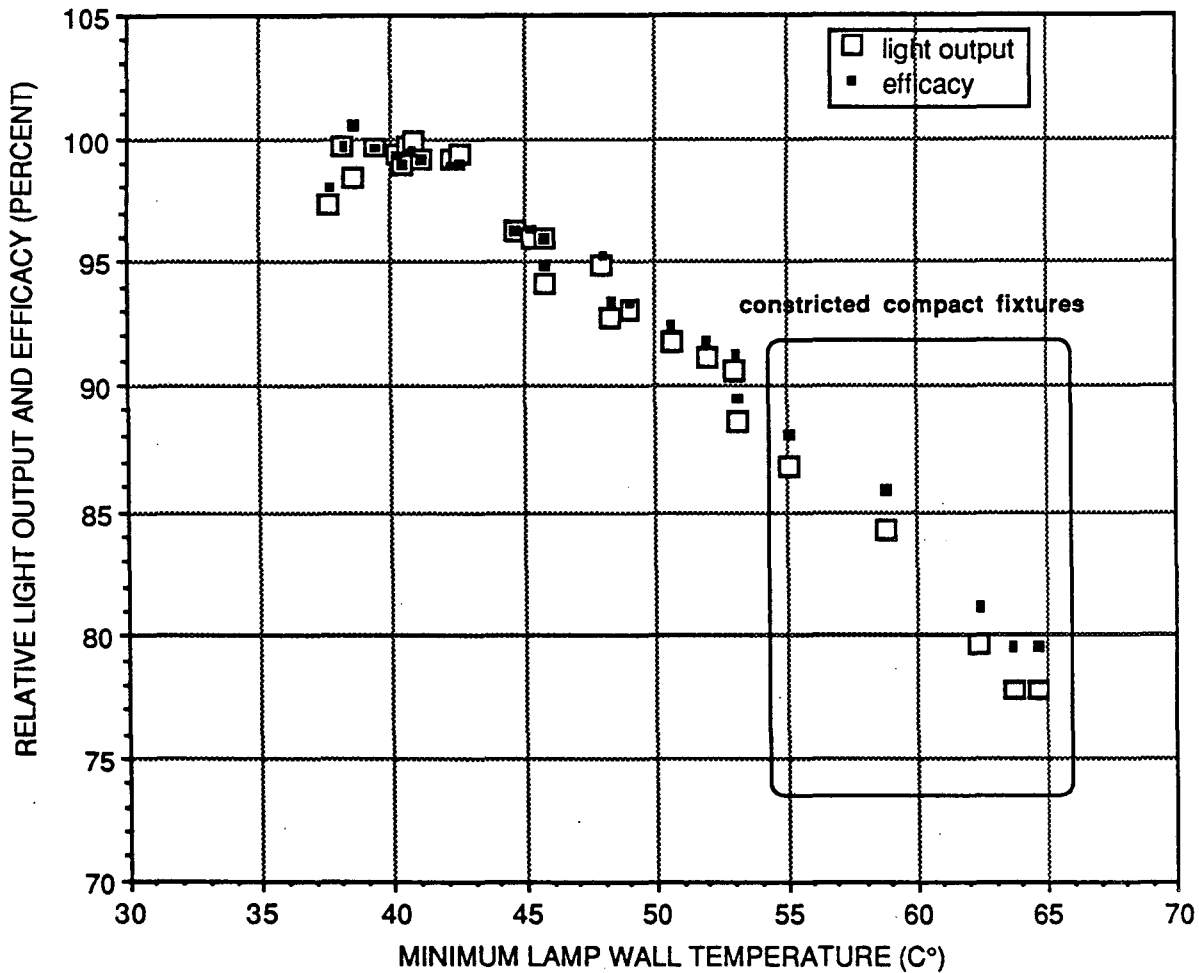

Figure 1. Light output and efficacy as a function of MLWT

When a compact fluorescent is placed within a small or thermally tight fixture geometry, convective cooling of the lamp surface is restricted. This results in the overheating of the lamp with a corresponding increase in MLWT. As shown in figure 1, MLWT can range between 55-65C° inside tightly constricted fixture environments. This results in thermally based efficacy and light output losses that can approach 20%. Research has been directed at studying the thermal performance of these lamp systems inside typical fixtures and to develop methods that could enhance the fixture efficiency through thermal management. These methods involve the cooling of the lamp with small heat sinks that dissipate heat generated to the surrounding ambient, and the use of convective venting of the lamp compartment which results in cooler lamp temperatures. Thermally enhanced compact fluorescent fixtures offer the potential of maintaining the lumen output of the compact lamp inside constricted fixture geometries and therefore maximizing its replacement capability.

METHODOLOGY

The light output and efficacy characteristics of a range of compact fluorescent fixture systems were studied. These fixtures were operated within a simulated ceiling-plenum environment under temperature controlled conditions (Fig. 2). The fixtures are installed within the simulated plenum and operated for a period of 3-4 hours to achieve thermal equilibrium. The lamp, ballast and fixture systems were all previously operated in place to assure establishment of a stable mercury cold spot. During each experimental run, relative light output, power input and temperatures were measured.

Each fixture configuration was tested both with and without a specific thermal management system in order to assess the effect of lamp cooling on fixture efficiency.

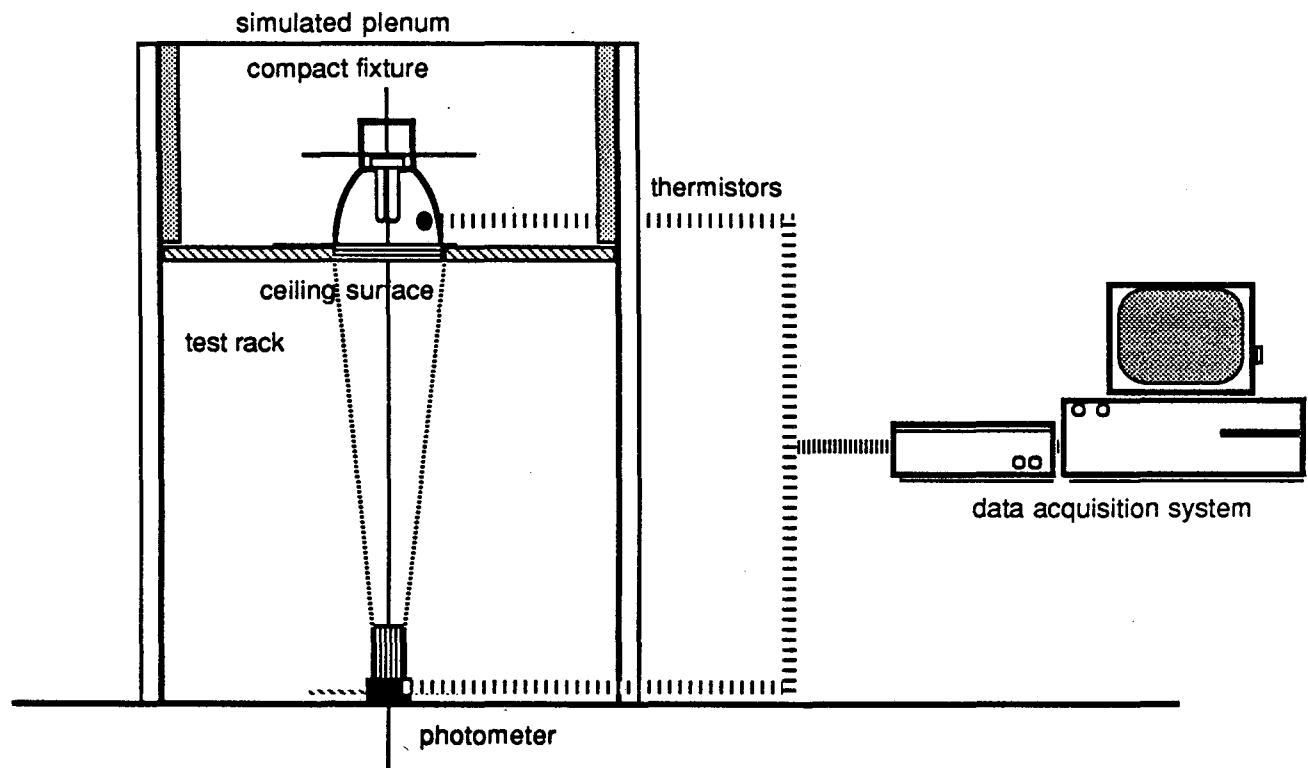

Figure 2. Schematic of experimental set-up.

The fixture configurations tested in this study included:

13 watt retrofit fixture- This fixture includes a 13 watt compact fluorescent lamp, an integral reflector, lens system, Edison base and ballast. It is principally used as a screw-in retrofit to replace an incandescent lamp within an existing recessed down light. Figure 3 shows a cross section of the standard retrofit fixture including the added thermal management modification of a heat sink assembly which is attached to the lens of the fixture. The heat sink assembly is designed to cool a small portion of the end of the compact lamp thereby reducing the cold spot temperature.

cross section through 13 watt retrofit fixture
with heat sink system

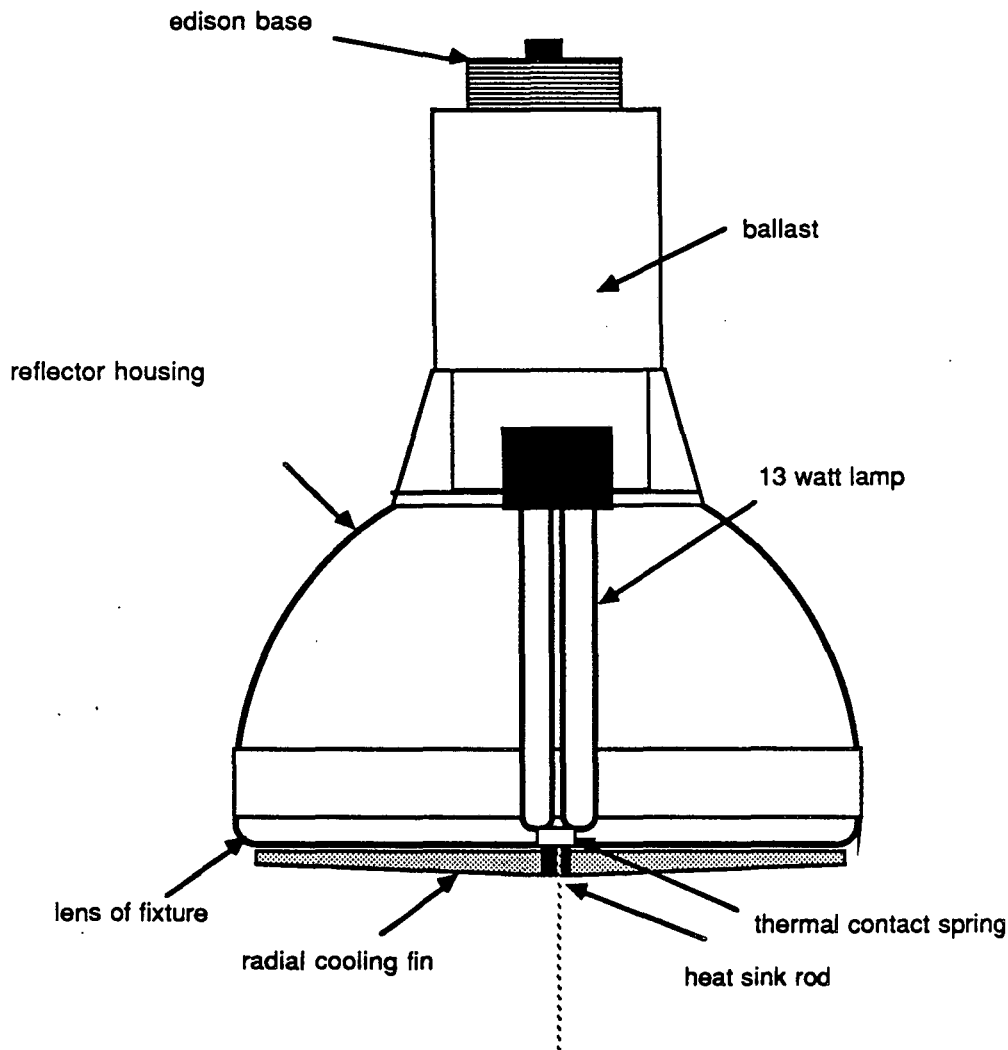

Figure 3. Cross section of retrofit fixture with heat sink assembly

The heat sink assembly is attached to the removable lens and includes a conductive spring contact, a center shaft and a series of radial vanes. As the lens is positioned on the fixture, the heat sink assembly comes into contact with the end of the lamp via the small conductive spring contact. This contact area permits the conductive cooling of a small area on the lamp wall. Heat is then conducted away through the lens by the center contact rod and is dissipated to the ambient environment by a series of small radial vanes. Experimental studies indicate that optical losses due to the assembly are on the order of 2-3%. Figure 4 shows a schematic of the heat sink assembly identifying

the major components. Previous experimental studies have indicated that this contact need only touch one point on the lamp with an area of approximately 1/10 of a square inch. This contact has a spring action which maintains thermal contact via pressure and makes up for manufacturer's tolerances in lamp length.

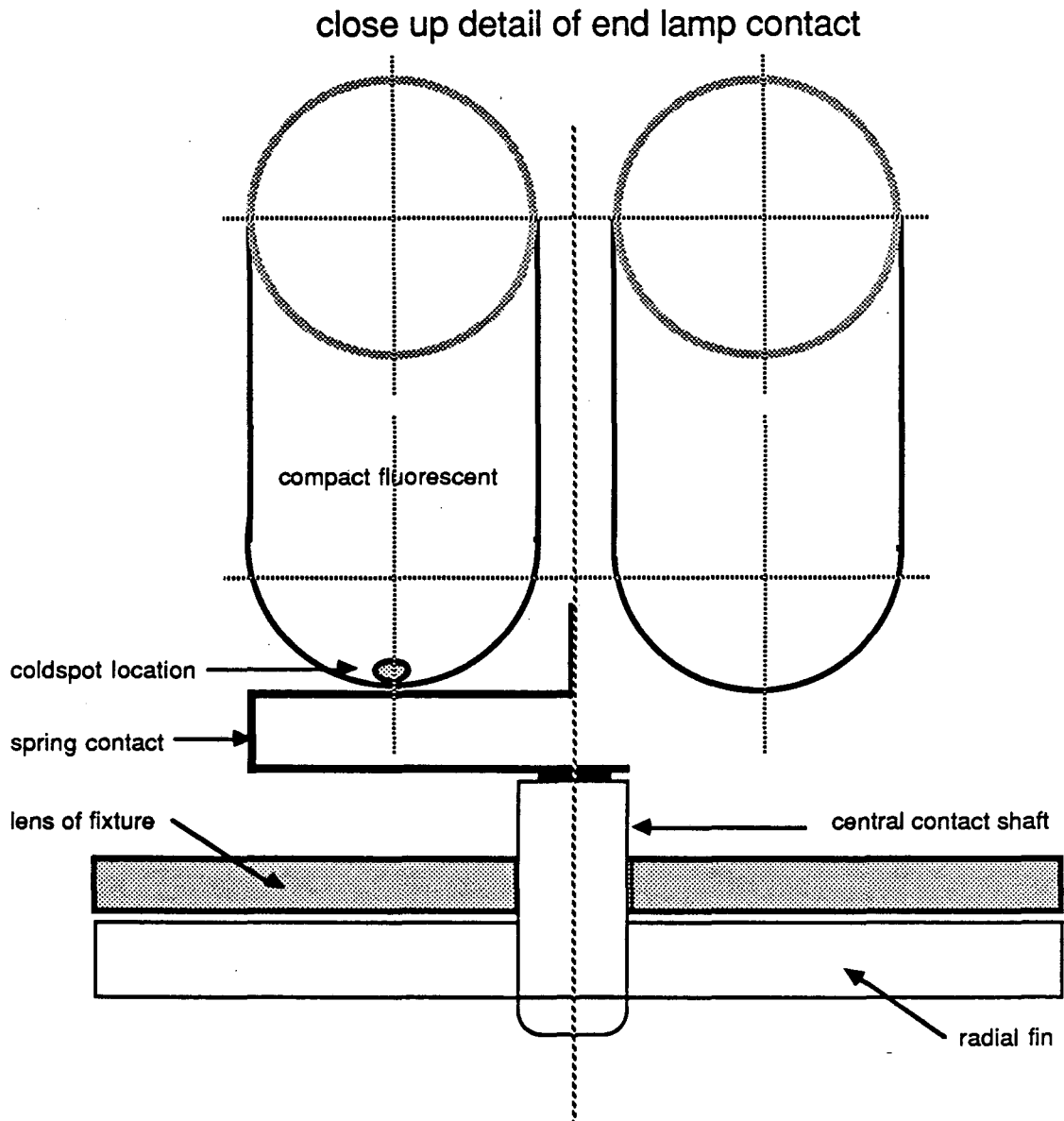

Figure 4. Detail of heat sink assembly

Recessed down light using two 26 watt lamps

This fixture includes two 26 watt lamps mounted horizontally within an open recessed reflector fixture. The fixture is designed to be recessed mounted within a suspended ceiling and is used primarily for new construction. The recessed fixture was modified to incorporate venting apertures to induce a convective air flow directly across the

location of the minimum lamp wall temperature at the ends of the lamps. Figure 5 shows cross sections of the standard recessed fixture and the same fixture modified to incorporate convective venting. The primary air flow pattern is indicated.

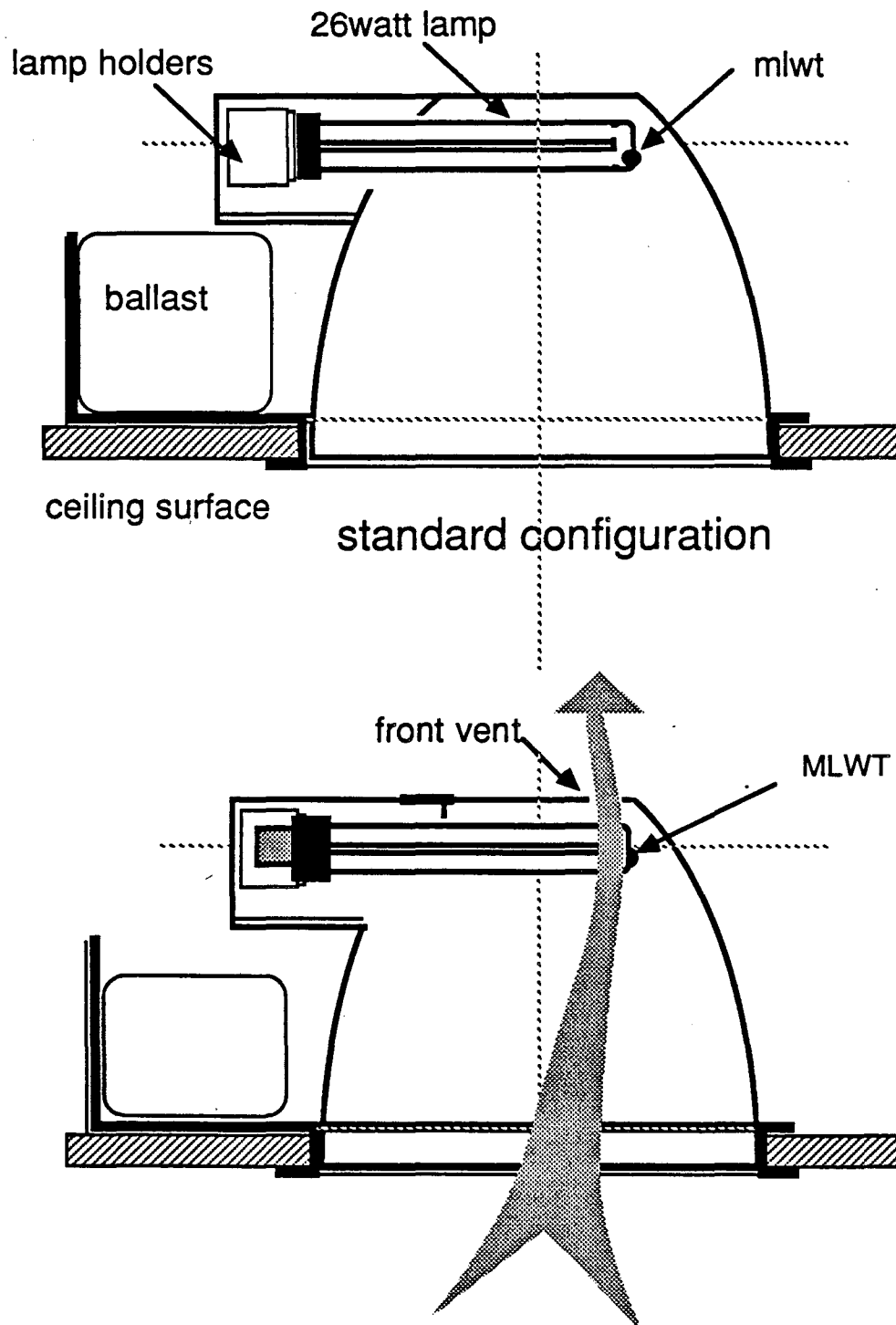

Figure 5. Cross section through standard recessed fixture and fixture with convective venting, illustrating the primary convection pattern across lamps

EXPERIMENTAL DATA

13 watt retrofit fixture-

Figure 6 plots the variations in efficacy and light output over time for both configurations of the retrofit compact fluorescent fixture. For the standard fixture, both light output and efficacy reach a maximum after 5-6 minutes of operation. Light output and efficacy then decrease to approximately 80% of the maximum after three hours of operation at which point the MLWT reaches a temperature of 60-65°C.

For the fixture operating with the heat sink assembly, light output reaches its maximum somewhat later than the standard fixture: 20-30 minutes after the lamp is energized as the MLWT of the lamp is heavily conditioned by the cooler ambient. System efficacy and light output are then maintained at 98-99% of the maximum for the duration of the experiment. The MLWT stabilizes at approximately 42-45°C. In comparison to the fixture operating without the heat sink system, this represents an approximate 20% increase in light output and system efficacy.

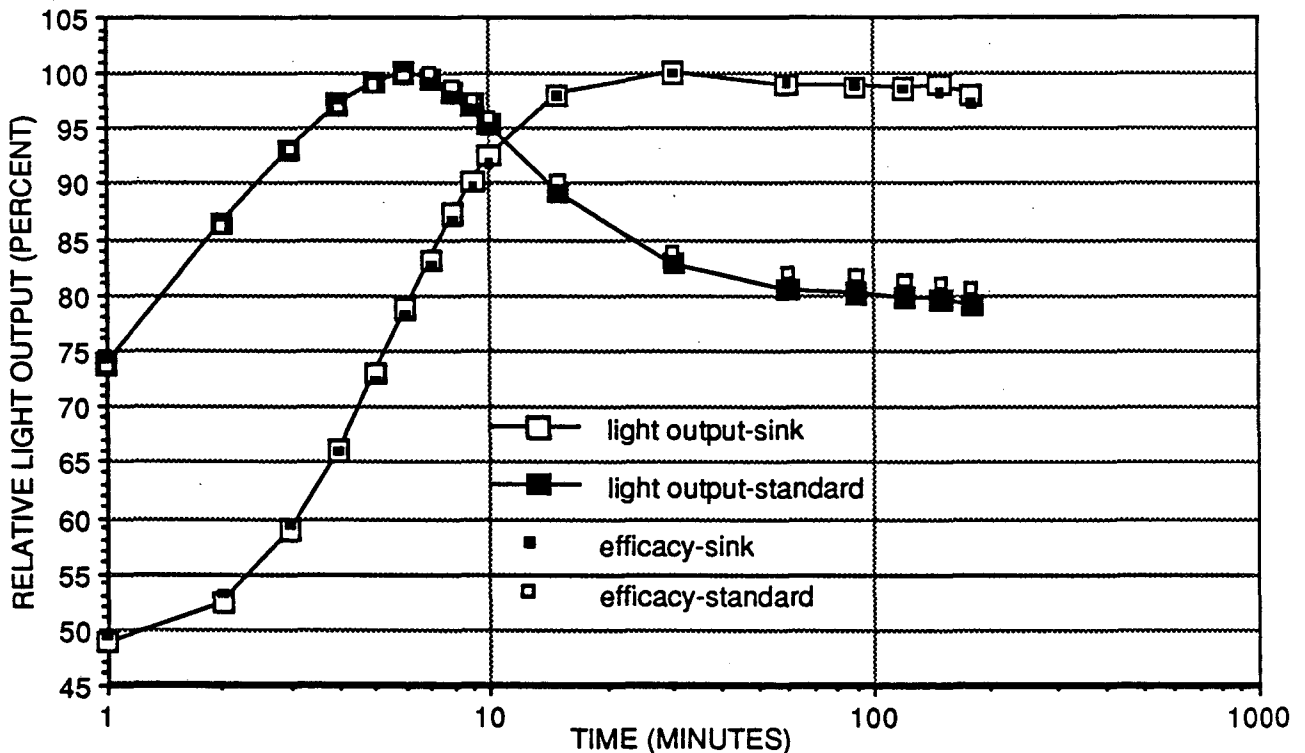

Figure 6. Light output and efficacy for the 13 watt retrofit fixture operating with and without a thermal management system

Recessed down light using two 26 watt lamps

Figure 7 plots the changes in system efficacy and light output for both the vented and unvented 2x26 watt recessed down light fixture over the period of three hours. For the unmodified fixture, efficacy and light output reach a maximum 2-3 minutes after the fixture is energized. Both efficacy and light output then decrease to approximately 83% and 80% of maximum, respectively, over the duration of the experiment. MLWT reaches approximately 60-65C° due to the constricted layer of air that is trapped at the top of the reflector. This air layer greatly reduces the convective cooling of the lamp wall. For the vented fixture, light output and efficacy reach their maximum at 5-6 minutes after the fixture is turned on. Both are reduced to approximately 95-96% of their maximum after three hours of operation. MLWT is reduced to approximately 45C°. The cooler operation of the lamps due to convective venting results in an approximate 15-20% increase in efficacy and light output.

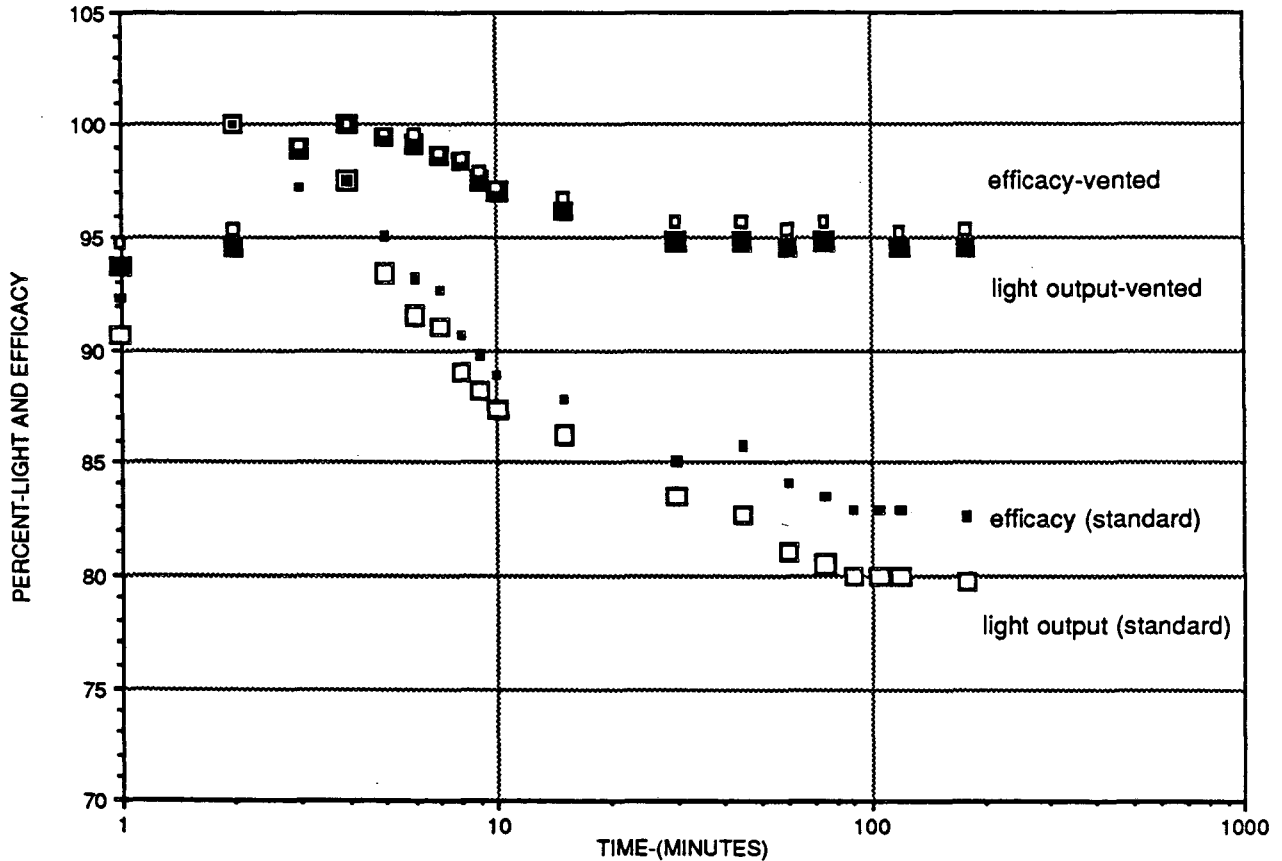

Figure 7. Light output and efficacy for recessed fixture operating with and without convective venting.

DISCUSSION

Thermal management systems have been shown to increase both the efficacy and light output of the fixture. However, increasing the lumen output and efficacy of fixture systems has different implications depending on whether the fixture is designed for retrofit or new construction applications. In retrofit applications, thermally based efficiency enhancement is primarily directed toward increases in lumen output from the fixture. The efficacy increase with thermal control does not effect a significant change in power input, just an increase in light output for the same wattage. This results in no direct energy savings. However the primary motivation in retrofit applications is to maximize the replacement potential of the compact fixture in terms of displacing incandescent load. This point is most effectively shown by example. A 13 watt compact fluorescent has a rated output of about 900 lumens, roughly equivalent in lumen output to an incandescent 75 watt reflector lamp. However as discussed in this paper, in the thermally restricted space of a small fixture the compact lamp without any thermal control actually produces only 720 lumens. This is approximately equal to the lumen output of a 65 watt incandescent flood. To be an equivalent replacement for the 75 R lamp requires that the 13 watt compact lamp be equipped with thermal control. The simple expedient of using a higher wattage compact lamp to compensate for thermal losses will not work for many applications, as the small size of the fixture will not accommodate a larger lamp with a higher lumen output. The above argument is especially important because many fixture applications currently use incandescent lamps of 75 watts and higher. This lumen output range is difficult or impossible to achieve with the short range of compact fluorescent lamps unless some form of thermal control is used. Thus appropriate thermal control will greatly expand the share of the incandescent market that can be replaced by the far more efficient compact fluorescent.

In new design applications, increasing the light output and efficacy in new fixtures with thermal management systems results in both energy saving and capital cost savings. In new construction the designer will be meeting a specific design illuminance level as determined by the architect or code requirements. The efficacy increases that result from thermal control lead directly to more lumens delivered per unit power available in new design applications. The designer can account for the increase in efficiency within the design process and achieve a conservation benefit resulting from the efficiency enhancement.

Secondly in new design, fixtures with higher fixture efficiency from increased lumen output will result in a smaller number of fixtures required to maintain a specific illuminance level. This will lead to reduced building costs and less maintenance in terms of relamping.

Compact fluorescent fixtures are being used increasingly in new construction specifically in response to some of the newer state energy codes. The increase in fixture efficiency that results from the use of thermal control will expand the application of the compact fluorescent in terms of incandescent displacement.

CONCLUSION

Thermal conditions encountered within typically constricted compact fluorescent fixtures can lead to light output and efficacy losses that approach 20%. These losses can be mitigated with thermal management systems that cool the minimum lamp wall temperature within the fixture. This approach includes the use of heat sinking the lamp directly to the surrounding air and the use of convective venting through the lamp compartment.

Appropriate thermal control of the compact fluorescent lamp/fixture system is an important consideration in order to effectively realize the full potential of the compact fluorescent in terms of its ability to displace incandescent sources. With increased application of higher wattage, higher lumen output compact fluorescent systems it will become even more important to consider the thermal losses that occur within constricted fixtures.

ACKNOWLEDGEMENT

The work described in this paper was supported by the Assistant Secretary for Conservation and Renewable Energy, Office of Building Technologies, Building Equipment Division of the U.S. Department of Energy under Contract No. DE-AC03-76SF00098.

REFERENCES

- [1] A. Bouwknecht. "Compact Fluorescent Lamps". Journal of the Illuminating Engineering Society, July 1982.
- [2] C. Verheij. "New steps in Development of Compact Single-ended Fluorescent Lamps". Journal of the Illuminating Engineering Society Fall 1985.
- [3] Siminovitch M., Rubinstein F. "Thermal Performance of Compact Fluorescent Fixtures". Proceedings of the Lighting Efficiency Congress, Association of the Energy Engineers, Santa Clara, 1990.
- [4] PL lamps Technical Data, Philips Lighting Report P-1071-B.

LAWRENCE BERKELEY LABORATORY
UNIVERSITY OF CALIFORNIA
INFORMATION RESOURCES DEPARTMENT
BERKELEY, CALIFORNIA 94720