

An evolutionary ‘intermediate state’ of mitochondrial translation systems found in *Trichinella* species of parasitic nematodes: co-evolution of tRNA and EF-Tu

Masashi Arita¹, Takuma Suematsu^{1,2}, Arihiro Osanai³, Takashi Inaba^{3,4}, Haruo Kamiya³, Kiyoshi Kita², Masahiko Sisido¹, Yoh-ichi Watanabe² and Takashi Ohtsuki^{1,*}

¹Department of Bioscience and Biotechnology, Okayama University, 3-1-1 Tsushimanaka, Okayama 700-8530, Japan, ²Department of Biomedical Chemistry, The University of Tokyo, 7-3-1 Hongo, Tokyo 113-0033, Japan, ³Department of Parasitology, Hirosaki University School of Medicine, 5, Zafu-cho, Hirosaki, Aomori 036-8562, Japan and ⁴Department of Medical Technology, Hirosaki University, Hirosaki, Aomori 036-8564, Japan

Received May 19, 2006; Revised July 5, 2006; Accepted July 8, 2006

ABSTRACT

EF-Tu delivers aminoacyl-tRNAs to ribosomes in the translation system. However, unusual truncations found in some animal mitochondrial tRNAs seem to prevent recognition by a canonical EF-Tu. We showed previously that the chromadorean nematode has two distinct EF-Tus, one of which (EF-Tu1) binds only to T-armless aminoacyl-tRNAs and the other (EF-Tu2) binds to D-armless Ser-tRNAs. Neither of the EF-Tus can bind to canonical cloverleaf tRNAs. In this study, by analyzing the translation system of enoplean nematode *Trichinella* species, we address how EF-Tus and tRNAs have evolved from the canonical structures toward those of the chromadorean translation system. *Trichinella* mitochondria possess three types of tRNAs: cloverleaf tRNAs, which do not exist in chromadorean nematode mitochondria; T-armless tRNAs; and D-armless tRNAs. We found two mitochondrial EF-Tu species, EF-Tu1 and EF-Tu2, in *Trichinella britovi*. *T. britovi* EF-Tu2 could bind to only D-armless Ser-tRNA, as *Caenorhabditis elegans* EF-Tu2 does. In contrast to the case of *C.elegans* EF-Tu1, however, *T. britovi* EF-Tu1 bound to all three types of tRNA present in *Trichinella* mitochondria. These results suggest that *Trichinella* mitochondrial translation system, and particularly the tRNA-binding specificity of EF-Tu1, could be an intermediate state between the canonical system and the chromadorean nematode mitochondrial system.

INTRODUCTION

Recently, sequencing of metazoan mitochondrial (mt) genomes has proceeded at an accelerated pace. The typical metazoan mt genome is small (14–20 kb) and carries only 37 genes, of which 22 are tRNA genes (1,2). From the mt genome sequences, it has been deduced that mt translation systems of metazoans, particularly invertebrates, include a variety of tRNAs that are truncated as compared to the canonical tRNAs with the common cloverleaf secondary structure (3). Metazoan mt tRNA^{Ser}(AGN) genes lack the potential to form the D arm (4), and loss of the T arm has been described for the mt tRNAs from nematodes (5–10), an acanthocephalan (11), trematodes [reviewed in (12)], mollusks (13,14), brachiopods (15,16) and arthropods (17). The most unusual situation occurs in a group of nematodes: the mitochondria of several nematodes of the class Chromadorea (including *Caenorhabditis elegans*, *Ascaris suum* and *Onchocerca volvulus*) have two structurally distinct types of tRNAs, one that lacks the T arm (20 tRNA species) and the other that lacks the D arm (two tRNAs^{Ser}) [reviewed in (18–20)]. It has been a mystery how these truncated tRNAs can function in the translation system. In particular, the T arm is necessary for the binding of aminoacyl-tRNAs to the canonical elongation factor Tu (EF-Tu) (21,22). Our recent study showed that a special EF-Tu (EF-Tu1) with an unusual C-terminal extension compensates for the lack of the T arm in *C.elegans* mt tRNAs (23). In *C.elegans* mitochondria, there is a second EF-Tu species (EF-Tu2) that is specific to the serine moiety of Ser-tRNA (24). How have these unique EF-Tu species evolved from the canonical EF-Tu? Understanding how EF-Tu enlargement compensates for tRNA truncation is important for understanding the evolutionary transition from the RNA world to the ribonucleoprotein world.

*To whom correspondence should be addressed. Tel: +81 86 251 8220; Fax: +81 86 251 8219; Email: ohtsuk@cc.okayama-u.ac.jp

Trichinella species, the parasites that cause trichinosis, are classified in the class Enoplea of the phylum Nematoda. It has been reported recently that *Trichinella spiralis* mt DNA contains genes that encode three distinct types of tRNAs: T-armless tRNAs, D-armless tRNAs and cloverleaf tRNAs with a short T arm (25). We therefore postulated that the translation system of *Trichinella* species might be an intermediate evolutionary state between the canonical system that uses only cloverleaf tRNAs and the unusual chromadorean system that uses only tRNAs lacking the T or D arm. In the present study, we confirmed that the *T. spiralis* mt translation system does include at least one cloverleaf tRNA. We cloned two EF-Tu species from *Trichinella britovi*, which is a close relative of *T. spiralis*, and analyzed their aminoacyl-tRNA specificity.

MATERIALS AND METHODS

Parasite

T. britovi, isolated in 1974 (26), was maintained using ICR mice. Muscle larvae were obtained from infected ICR mice by digestion in artificial gastric juice [0.8% (w/v) pepsin and 0.8% (v/v) HCl in physiological saline] for 3 h at 37°C, then washed several times with phosphate-buffered saline (26). The worms were frozen in liquid nitrogen and stored at -80°C until use.

cDNA cloning of *T. britovi* EF-Tu1 and EF-Tu2

The frozen parasitic worms were crushed with a Cryo-Press Frozen Cell Crasher (Microtec, Japan) and poly(A)-plus RNA was prepared with PolyATtract system (Promega). Reverse transcription was carried out with ReverTra Ace (Toyobo, Japan) and random hexamers. The partial cDNA fragment of the putative EF-Tu was obtained by PCR using the degenerate primers P-748 (5'-AC(G,T)AT(A,T)GG(T,C,A,G)CA(T,C)(A,G)T(T,C,A,G)GA(T,C)CA-3')/P-750 (5'-TC(G,T)G(A,C)(A,G)TG(T,C,A,G)CC(T,C,A,G)GG(A,G)CA(A,G)TC-3') and P-749 (5'-CA(T,C)(A,G)T(G,T)GA(T,C)CA(T,C)GG(T,C,A,G)AA(A,G)AC-3')/P-750. The putative cDNA fragments were purified with agarose gel electrophoresis and then cloned using a TOPO TA cloning kit (Invitrogen). Positive clones were screened by colony PCR and sequenced using a DYEnamic ET Terminator Sequencing Kit (GE Healthcare) and a PRISM 310 genetic analyzer (Applied Biosystems). The full-length cDNAs (accession numbers EF-Tu1, AB251621; EF-Tu2, AB251622) were reconstructed from cloned RACE fragments prepared with a GeneRacer kit (Invitrogen) and specific primers (for EF-Tu1, 5'-GCCACGTTTATCGTAATCCACGGCT-3' for 5' RACE, 5'-CGGTAAaACGACACTTACGTCGGCAA-3' for 3' RACE; for EF-Tu2, 5'-TTCTCGTTGTTGCTCTTCTGTGCTTTGT-3' and 5'-TGCTCTTCTGGTGTCTTTGTCGAT-TTCGTCG-3' for 5' RACE, 5'-CGACGAAATCGACA-AAGCACCAGAAGAGCA-3' and 5'-ACAAAGCACCA-GAAGAGCAACAACGAGGAA-3' for 3' RACE).

Construction of expression vectors

To construct vectors expressing the EF-Tus with N-terminal thrombin-cleavable His-tags, the putative mature protein-coding regions with 5' methionine codons were amplified

with 5'-CCGcatatgGTGAGCGTAAAAGCTGTTTAC-3' and 5'-GGGgatccTCATTCCCCTTCAATTTCAA-3' for EF-Tu1; and 5'-CCGcatatgGAGTATGAATTGAGCAACTACT-3' and 5'-GGGgatccTCACTGAACTTTCTTTGTTAA-3' for EF-Tu2 using the cDNA as a template. (NdeI and BamHI sites in the oligos are shown in lower case.) The products were cloned into pGEM-T (Promega) and the sequences were verified. The verified inserts were excised by NdeI and BamHI and then cloned between the NdeI and BamHI sites of pET-15b (Novagen).

Sequence analysis

Sequence alignments were generated with ClustalW version 1.83 (27) followed by manual modification. Based on the alignment, 379 amino acid positions were selected for phylogenetic analysis, with positions of insertion and deletion omitted. Phylogenetic trees were constructed using the maximum-likelihood method of protein phylogeny in the Phylml 2.5 program (28). The WGA + γ model of amino acid substitutions was assumed in the analysis (29,30). Rate heterogeneity among sites was approximated by a discrete gamma distribution (with four categories).

Preparation of the recombinant *T. britovi* mitochondrial EF-Tus

Escherichia coli strain C41 (DE3) or BL21 (DE3) was transformed with the pET-15b-derived expression vector harboring *T. britovi* EF-Tu1 or EF-Tu2 with N-terminal His tags. The transformed cells were grown, harvested by centrifugation and then lysed by sonication and fractionated as described previously (23) with slight modification. Buffer A [50 mM HEPES-KOH (pH 7.5), 150 mM (NH₄)₂SO₄, 7 mM MgCl₂, 20% glycerol, 15 μ M GDP, 7 mM β -mercaptoethanol and 100 μ M phenylmethylsulfonyl fluoride] was used to resuspend the cells, Buffer B [50 mM HEPES-KOH (pH 7.5), 1 M NH₄Cl, 10 mM imidazole, 20% glycerol, 1.3 μ M GDP and 5 mM β -mercaptoethanol] was used for washing the Ni-NTA column, and Buffer C [50 mM HEPES-KOH (pH 7.5), 100 mM (NH₄)₂SO₄, 150 mM imidazole, 20% glycerol, 2 μ M GDP and 5 mM β -mercaptoethanol] was used for eluting the His-tagged protein. The obtained protein was treated with biotinylated thrombin during dialysis to digest the His tag at the N-terminus and was purified with streptavidin agarose.

Preparation of tRNAs

A. suum mt tRNA^{Lys} was purified from *A. suum* as described previously (31). All other tRNAs used in this study were prepared by *in vitro* transcription. To generate DNA templates for the transcription, primer extension reactions were performed using KOD Dash DNA polymerase (TOYOBO) and two primers designed to complement each other at their 3' regions (~20 nt). In the DNA templates, the promoter sequence for T7 RNA polymerase was directly connected to the upstream region of the tRNA sequence. The transcription reaction was performed at 37°C for 4 h in a reaction mixture that included 40 mM Tris-HCl (pH 8.0), 6 mM MgCl₂, 5 mM DTT, 1 mM spermine, 0.01% Triton X-100, 50 μ g/ml BSA, 10 mM GMP, 0.5 mM each of ATP, GTP, CTP and UTP, 90 μ g/ml T7 RNA polymerase and 10 μ g/ml template

DNA. For *T. spiralis* mt tRNA^{Trp}, which bears an A at its 5' end, a hammerhead ribozyme sequence was introduced between the T7 RNA polymerase promoter and the tRNA sequence in the transcription template, and its transcript was cleaved by the ribozyme to separate the tRNA^{Trp} and the ribozyme according to a method described previously (32). The products were purified by 10% denaturing PAGE.

Enzymatic probing of tRNA

Enzymatic probing of *T. spiralis* tRNA^{Trp} was performed according to a method described previously (8). 5'-³²P-labeled tRNAs were digested with RNase T₂ (2.5×10^{-5} or 6×10^{-6} U) or RNase V₁ (0.09 or 0.0225 U) in 5 μ l of 50 mM sodium acetate (pH 6.0) and 10 mM MgCl₂. The digestion was performed at 37°C for 7 min.

Preparation of aminoacyl-tRNAs using aminoacyl-tRNA synthetases

Bovine mt Ser- or Ala-tRNA^{Ser} was prepared as described previously (33). Mitochondrial [³H]Lys-tRNA^{Lys} of *T. spiralis* and *A. suum*, and *Drosophila melanogaster* mt [³⁵S]Cys-tRNA^{Cys} were prepared using recombinant *C. elegans* putative mt lysyl-tRNA synthetase (LysRS) and putative mt cysteinyl-tRNA synthetase (CysRS), respectively. *C. elegans* LysRS and CysRS were expressed in *E. coli* Rosetta (DE3) (Novagen) using expression vectors derived from pET-28b (Novagen) and prepared using cDNA clone yk468a3 for LysRS and cDNA clone yk79g12 for CysRS, which were kindly provided by Prof. Y. Kohara. Aminoacylation reactions were performed at 37°C for 30 min in a reaction mixture that contained 50 mM HEPES-KOH (pH 7.8), 10 mM MgCl₂, 1 mM spermine, 20 mM KCl, 2.5 mM ATP, 2 mM DTT, 30 μ M [³H]lysine (74 Bq/pmol) or [³⁵S]cysteine (39.8 kBq/pmol), 320 μ g/ml aminoacyl-tRNA synthetase (ARS) and 0.002–0.005 A₂₆₀unit/ μ l of tRNA. The aminoacyl-tRNAs were purified as described previously (23) and finally dissolved in 6 mM KOAc (pH 5.0) at a concentration of 2 μ M. The concentration of aminoacyl-tRNA was estimated from the labeled amino acids incorporated into the tRNA.

Chemical aminoacylation

Phe-tRNA^{Lys} and Phe-tRNA^{Trp} of *T. spiralis* mitochondria were prepared by ligating the tRNA transcript without the 3'-CA sequence and the phenylalanyl-dinucleotide (p2'dCpA-Phe) with T4 RNA ligase as described previously (34,35). The purified Phe-tRNAs were dissolved with 6 mM KOAc (pH 5.0).

Hydrolysis protection assay

The assay was basically performed according to the method described in Refs (36,23). The deacylation reaction mixture contained 75 mM Tris-HCl (pH 7.5), 75 mM NH₄Cl, 15 mM MgCl₂, 7.5 mM DTT, 60 mg/ml BSA, 0.1 mM GTP, 2.375 mM phosphoenolpyruvate, 2.5 U/ml pyruvate kinase, 1.2 μ M EF-Tu and 0.2 μ M aminoacyl-tRNA. The reaction mixture was preincubated at 30°C for 10 min without aminoacyl-tRNA, after which aminoacyl-tRNA was added. The deacylation reaction was performed at 30°C.

Gel mobility shift assay

The ternary complex of *T. britovi* EF-Tu1, GTP and aminoacyl-tRNA was prepared as follows. The binary complex of EF-Tu1 and GTP was prepared at 30°C for 10 min in 12 μ l of a reaction mixture containing 2.4 mM Tris-HCl (pH 6.8), 3 mM NH₄OAc, 0.5 mM Mg(OAc)₂, 5 mM GTP, 50 mM phosphoenolpyruvate, 0.05 U/ μ l pyruvate kinase and 24 μ M EF-Tu1. To this solution, 0.1 A₂₆₀ unit of aminoacyl-tRNA was added, and the resulting mixture was incubated at 4°C for 10 min. Electrophoresis of the samples was carried out in 5% polyacrylamide gels at room temperature for 30 min at 50 V in a buffer containing 50 mM Tris-HCl (pH 8.0), 65 mM NH₄OAc, 10 mM Mg(OAc)₂ and 1 mM EDTA (pH 8.0). The gel was stained with ethidium bromide.

RESULTS

Sequences of *T. britovi* EF-Tu1 and EF-Tu2

Using cDNA cloning and sequencing of *T. britovi* EF-Tu, we found two EF-Tu homologues (EF-Tu1 and EF-Tu2). The amino acid sequence of *T. britovi* EF-Tu1 had 56% homology to that of *C. elegans* EF-Tu1 (Figure 1B). The T stem-binding residues commonly seen in canonical EF-Tu (21,22) were not conserved at all in *T. britovi* EF-Tu1, which had a C-terminal extension that is not seen in canonical EF-Tus (Figure 1B). Although the C-terminal extension of *T. britovi* EF-Tu1 (41 residues) is shorter than that of *C. elegans* EF-Tu1 (57 residues), these features of *T. britovi* EF-Tu1 do resemble those of *C. elegans* EF-Tu1, suggesting that *T. britovi* EF-Tu1 may recognize T-armless tRNAs, as *C. elegans* EF-Tu1 does (23). The amino acid sequence of *T. britovi* EF-Tu2 was significantly homologous (47%) to that of *C. elegans* EF-Tu2. *T. britovi* EF-Tu2 had a relatively short C-terminal extension (18 residues), similar to *C. elegans* EF-Tu2. In Figure 1B, the asterisks show the residues involved in the side-chain pocket of the aminoacyl group, which has been reported for canonical EF-Tu (21,22). At these positions, *T. britovi* EF-Tu2 was homologous to *C. elegans* EF-Tu2 but not to *Thermus thermophilus* EF-Tu (Figure 1B). Thus, *T. britovi* EF-Tu2 may be specific for the seryl group of seryl-tRNAs, as *C. elegans* EF-Tu2 is.

Secondary structure of *T. spiralis* mt tRNA^{Trp}

T. spiralis (Nematoda: Enoplea) mt DNA has been reported to encode three types of tRNAs, T-armless tRNAs, cloverleaf tRNAs with a short T arm and D-armless tRNAs (25), whereas mitochondria of chromadorean nematodes (e.g. *C. elegans*, *A. suum* and *O. volvulus*) do not have any cloverleaf tRNAs (5,7,9). To confirm that *T. spiralis* has cloverleaf tRNAs in its mitochondria, we analyzed the secondary structure of *T. spiralis* mt tRNA^{Trp}, which has been suggested to be a cloverleaf tRNA (37), in an enzymatic probing experiment. The digestion pattern is shown in Figure 2A and the results are summarized in Figure 2B. The digestion pattern shows that double strand-specific RNase V₁ cleaved the T stem region and single strand-specific RNase T₂ cleaved the T-loop region. These observations indicate the tRNA^{Trp} has a T arm and thus is a cloverleaf tRNA.

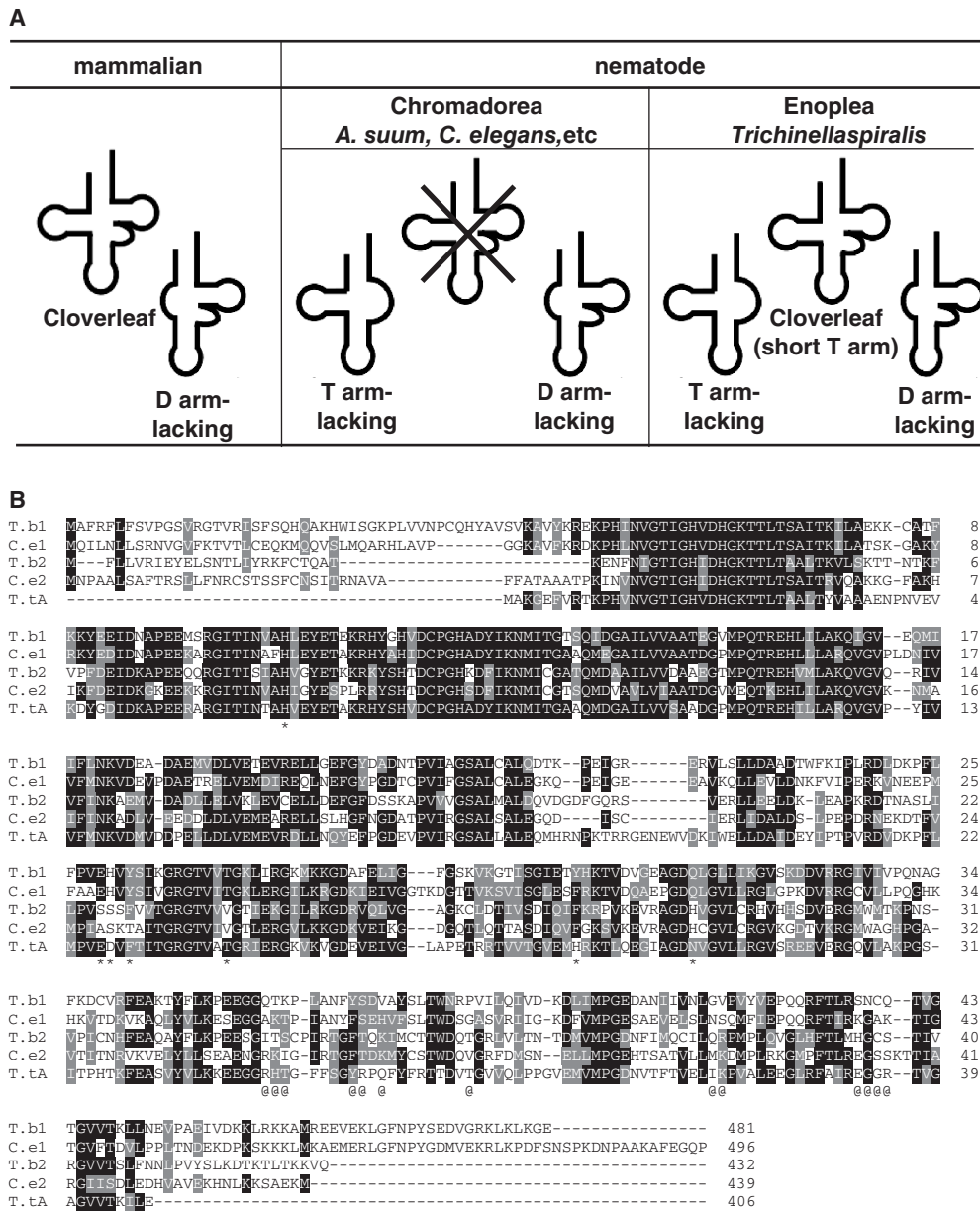

Figure 1. Characteristic features of *T. spiralis* mt tRNAs and *T. britovi* mt EF-Tus. (A) Secondary structures of mitochondrial tRNAs of the enoplean nematode *T. spiralis*, chromadorean nematodes and mammals. (B) Alignment of mitochondrial EF-Tus of *T. britovi* EF-Tu1 (T.b1, this study, accession no. AB251621), *T. britovi* EF-Tu2 (T.b2, this study, accession no. AB251622), *C. elegans* EF-Tu1 (C.e1, accession no. BAA07491) and *C. elegans* EF-Tu2 (C.e2, accession no. BAA31345), together with *T. thermophilus* EF-Tu (T.tA, Q5SHN6). The alignment was modified using BoXSHADE (http://www.ch.embnet.org/software/BOX_form.html). The black and gray shadings indicate identical and similar amino acid sequences, respectively. Asterisks indicate the residues involved in the side-chain pocket of the aminoacyl group, and '@' indicates the residues in contact with the T stem (21,22).

Trichinella EF-Tu1 binds to three types of tRNAs

To analyze the binding of *T. britovi* EF-Tus to T-armless tRNAs and to tRNAs with a short T arm, we first performed deacylation protection assays (36), in which the spontaneous deacylation rate of an aminoacyl-tRNA is suppressed when an EF-Tu binds to it. We employed native *A. suum* mt tRNA^{Lys} and transcripts of *T. spiralis* mt tRNA^{Lys} and *D. melanogaster* mt tRNA^{Cys} in this assay (Figure 3A–C). *A. suum* mt tRNA^{Lys} was used as an example of a T-armless tRNA. *D. melanogaster* mt tRNA^{Cys} has a structure similar to the cloverleaf tRNAs of *T. spiralis* mitochondria, whose

T arms are shorter than those of canonical tRNAs. Although *T. spiralis* mt tRNA^{Lys} has been classified as a cloverleaf tRNA (37), it would seem difficult for this tRNA to form a stable T arm because the hypothetical T arm contains only 2 bp with a 4 base loop. The result of the enzymatic probing experiment implied that no T stem was formed in this tRNA (data not shown); this is not unusual, because more than half of *T. spiralis* mt tRNAs lack the T arm (37). About 14% of *T. spiralis* mt tRNA^{Lys} and 41% of *A. suum* mt tRNA^{Lys} were lysylated by *C. elegans* mt LysRS, and 12% of *D. melanogaster* tRNA^{Cys} was charged with cysteine

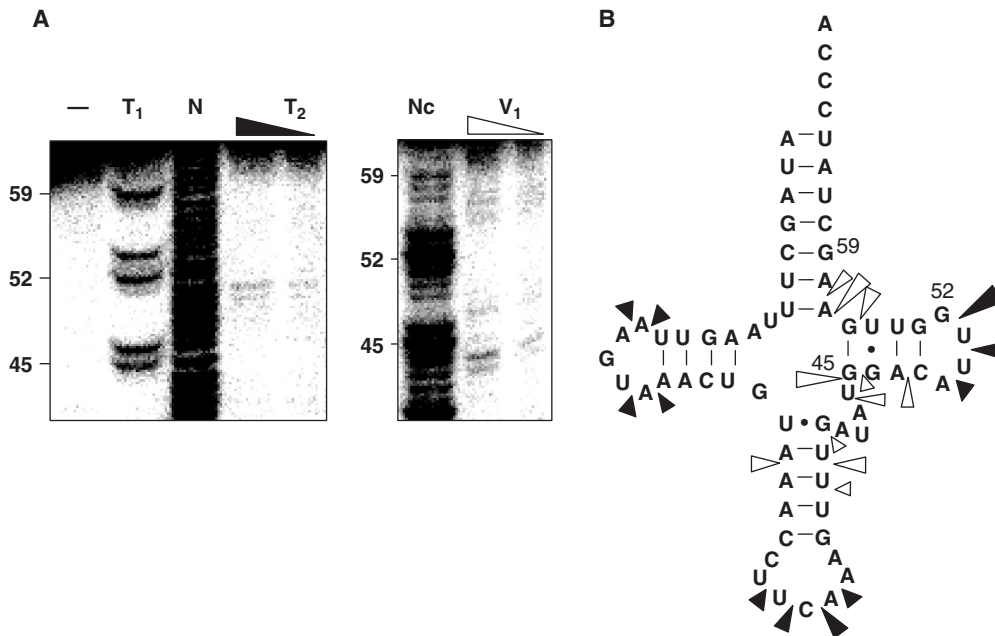

Figure 2. Enzymatic probing of 5'-labeled *T. spiralis* mt tRNA^{Trp}. (A) 5'-Labeled tRNA^{Trp} was reacted with 2.5×10^{-5} or 6×10^{-6} U of RNase T₂ and 0.09 or 0.0225 U of RNase V₁. The closed and open triangles indicate the decreasing amounts of RNase T₂ and V₁, respectively. Symbols: dash, untreated tRNA; N, alkaline ladder; T₁, RNase T₁ ladder; and Nc, ladder of digestion with *Neurospora crassa* endonuclease as a size marker for RNase V₁, which digests at the 5' side of phosphodiester bonds. (B) Secondary structure of *T. spiralis* mt tRNA^{Trp}. Closed and open triangles indicate the cleavage sites with RNase T₂ and RNase V₁, respectively. The cleavage strengths are shown by the triangle sizes. The 3mer at the 5' end and 8mer at the 3' end were not analyzed.

by *C. elegans* mt CysRS. *T. britovi* EF-Tu1 bound to the T-armless tRNAs and to the tRNA with a short T arm but EF-Tu2 did not (Figure 3D–F). The tRNA specificity of *T. britovi* EF-Tu1 was different from that of *C. elegans* EF-Tu1 in that *T. britovi* EF-Tu1 bound the tRNA with a short T arm but *C. elegans* EF-Tu1 did not.

The binding of *T. britovi* EF-Tu1 to the three types of tRNAs was also analyzed with a gel mobility shift assay (Figure 4). In this assay, we used *T. spiralis* mt Phe-tRNA^{Trp} as a cloverleaf tRNA with a short T arm (Figure 2), *T. spiralis* mt Phe-tRNA^{Lys} as a T-armless tRNA (Figure 3B) and bovine mt Ser-tRNA^{Ser_{GCU}} as a D-armless tRNA (Figure 5A). The tRNA^{Trp} and tRNA^{Lys} were chemically aminoacylated using p2'dCpA-Phe because ARSs did not aminoacylate these tRNAs efficiently enough for a gel-shift assay. The gel-mobility shift assay shows that all three of these aminoacyl-tRNAs bound to EF-Tu1 (Figure 4). The uncharged tRNAs (*T. spiralis* mt tRNA^{Trp} and tRNA^{Lys}, and bovine mt tRNA^{Ser_{GCU}}) did not bind to *T. britovi* EF-Tu1 (Supplementary Figure 2). The binding of the D-armless Ser-tRNA to *T. britovi* EF-Tu1 (Figure 5B) was unexpected because *C. elegans* EF-Tu1 does not bind to D-armless tRNAs (24). We also found that the EF-Tu1 could bind to cloverleaf tRNAs only if they had a short T arm, and could not bind to canonical cloverleaf tRNAs (Supplementary Figure 1).

***Trichinella* EF-Tu2 binds to D-armless Ser-tRNA but not to D-armless Ala-tRNA**

Our previous study showed that *C. elegans* EF-Tu2 exclusively recognizes the serine moiety of Ser-tRNA (24). In this study, we investigated whether *T. britovi* EF-Tu2 also

has serine specificity. In this assay, a bovine mt tRNA^{Ser_{GCU}} mutant (Figure 5A) was used because this tRNA can be charged with Ser by bovine mt seryl-tRNA synthetase and also with Ala by *E. coli* alanyl-tRNA synthetase (24). A deacylation protection assay was performed with *T. britovi* EF-Tu2 using either Ser-tRNA or Ala-tRNA (Figure 5). The tRNA bodies of the Ser-tRNA and Ala-tRNA are entirely the same. *T. britovi* EF-Tu2 bound to the Ser-tRNA but not to the Ala-tRNA (Figure 5B and C), whereas bovine mt EF-Tu and *T. britovi* EF-Tu1 bound to both Ser-tRNA and Ala-tRNA. This suggests that *T. britovi* EF-Tu2 is serine-specific, like *C. elegans* EF-Tu2. However, the esterified serine cannot be the only criterion for *T. britovi* EF-Tu2 binding; the tRNA part must also be important as *E. coli* Ser-tRNA^{Ser} failed to bind to EF-Tu2 (Supplementary Figure 1). In the case of bacterial EF-Tu, it is known that both the esterified amino acid and the tRNA part of the aminoacyl-tRNA contribute to the binding affinity of EF-Tu (38).

DISCUSSION

The lack of a T or D arm in some mt tRNAs seems to be related to the small size of the mt genome. However, the lack of a T arm requires some functional support, because the T arm is necessary for binding EF-Tu in the canonical translation system. Canonical EF-Tus, such as bacterial EF-Tu, can bind to canonical cloverleaf-type tRNA and D-armless tRNA (39) but not to T-armless tRNA (23). In contrast, EF-Tu1 from chromadorean nematodes binds specifically to T-armless tRNAs and cannot bind to cloverleaf tRNA (23). To understand the evolutionary process that has generated the T-armless tRNA, it is necessary to investigate

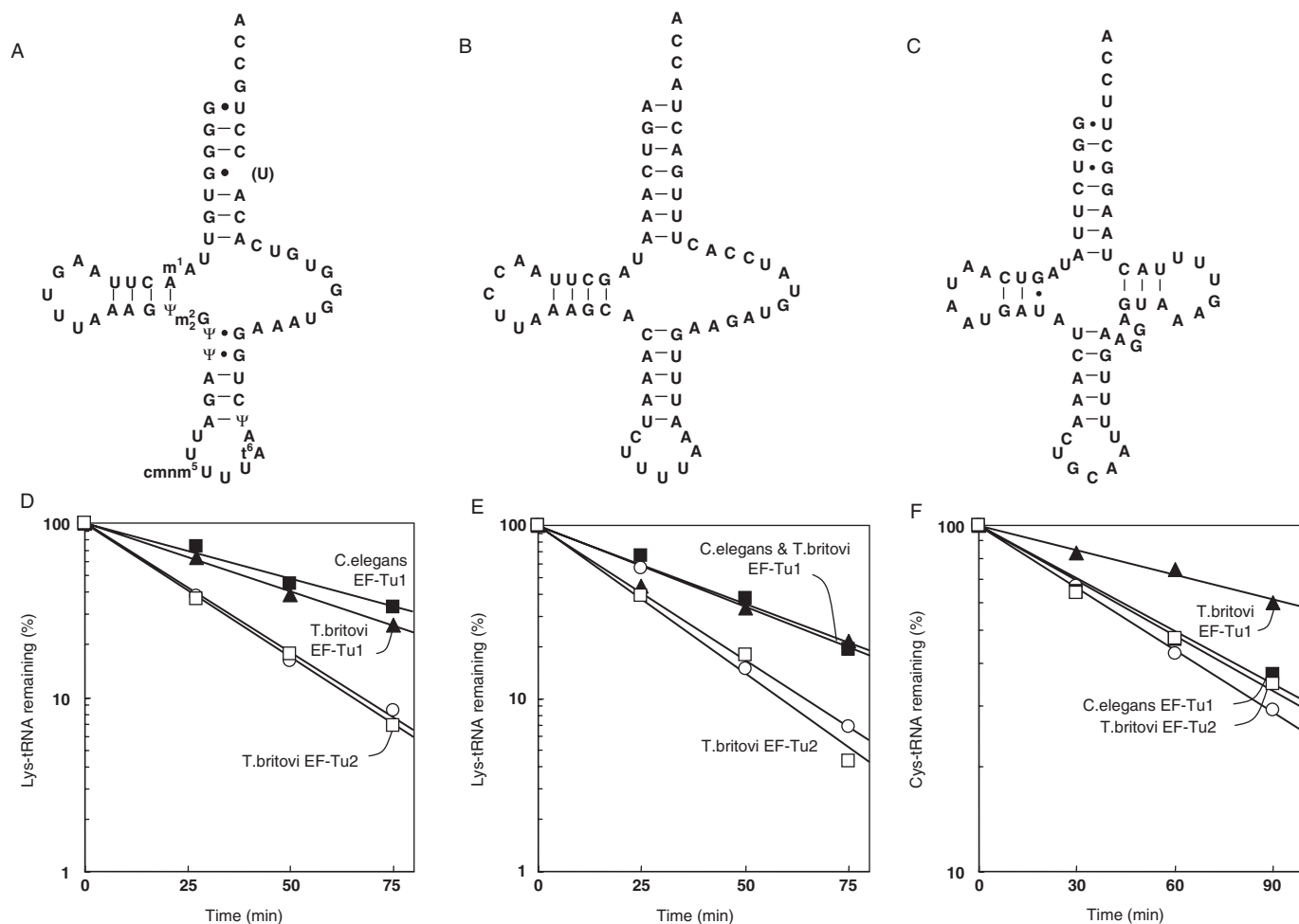

Figure 3. Binding of EF-Tu1 and EF-Tu2 to T-armless and cloverleaf (short T arm) tRNAs. (A–C) Sequences and secondary structures of (A) *A. suum* mt tRNA^{Lys} (5), (B) *T. spiralis* mt tRNA^{Lys} (37) and (C) *D. melanogaster* mt tRNA^{Cys} (43). (D–F) Deacylation-protection assay using (D) *A. suum* mt Lys-tRNA^{Lys}, (E) *T. spiralis* mt Lys-tRNA^{Lys} and (F) *D. melanogaster* mt Cys-tRNA^{Cys}. These assays were performed in the presence of *T. britovi* EF-Tu1 (closed triangles), *T. britovi* EF-Tu2 (open squares), *C. elegans* EF-Tu1 (closed squares) and in the absence of EF-Tu (open circles).

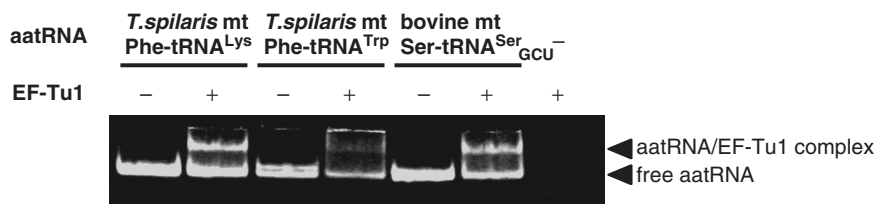

Figure 4. Binding of EF-Tu1 to three types of aminoacyl-tRNAs. *T. spiralis* mt Phe-tRNA^{Lys}, *T. spiralis* mt Phe-tRNA^{Trp} and bovine mt Ser-tRNA^{Ser} in the presence or absence of EF-Tu1 were analyzed by gel mobility shift assay under the conditions described in Materials and Methods. The gel was stained with ethidium bromide.

how EF-Tu co-evolved with tRNAs, including how the division of labor arose between the two EF-Tus of *C. elegans*, EF-Tu2 for the two D-armless tRNAs^{Ser} and EF-Tu1 for the other 20 T-armless tRNAs (24), given the ability of the canonical EF-Tu to deliver all elongator tRNAs. In this study, we found in *Trichinella* spp. an intermediate state in the evolutionary process that generates EF-Tu for T-armless tRNAs and divides the labor between different EF-Tus.

In this study, we found that the EF-Tu1 from the enoplean nematode *T. britovi* bound to all three types of tRNAs

that exist in *Trichinella* mitochondria: T-armless tRNAs, D-armless tRNAs and cloverleaf tRNAs with a short T arm (Figures 4 and 6). *T. britovi* EF-Tu1 thus seems to be in the evolutionary midstream between canonical EF-Tu and the chromadorean nematode EF-Tu1 that specifically binds to T-armless tRNA. *T. britovi* EF-Tu1 has a C-terminal extension of 41 residues compared to the canonical EF-Tu; this is shorter by 16 residues than that of *C. elegans* EF-Tu1, but the extension is 44% homologous to the N-terminal 41 residues of the C-terminal extension of *C. elegans* EF-Tu1.

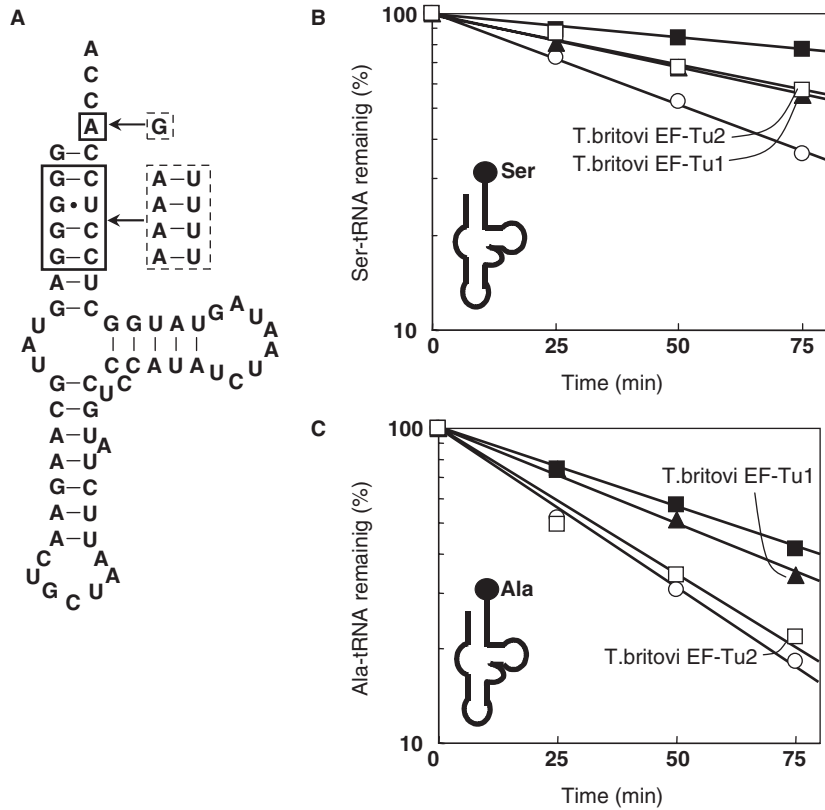

Figure 5. Serine specificity of EF-Tu2. (A) The secondary structure of the bovine mt tRNA^{Ser}_{GCU} derivative with alanine identity. The mutated residues are enclosed within the solid lines. For the mutated positions, the native sequence of tRNA^{Ser} is shown within the dotted lines. Deacylation protection assays using Ser-tRNA (B) and Ala-tRNA (C) were performed with bovine mt EF-Tu (closed squares), *T. britovi* EF-Tu1 (closed triangles), *T. britovi* EF-Tu2 (open squares) and in the absence of EF-Tu (open circles).

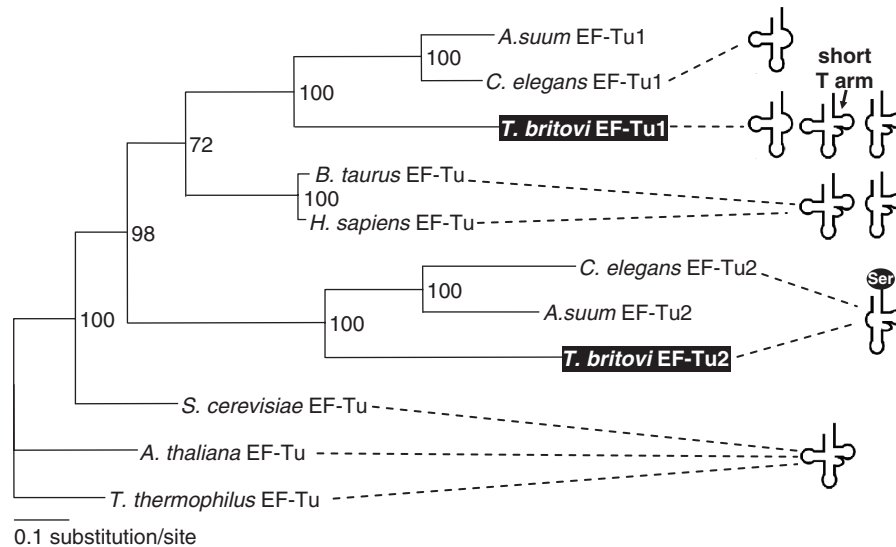

Figure 6. Phylogenetic representation of tRNA recognition patterns of mitochondrial EF-Tus. Numbers on branches are the bootstrap values from 100 pseudo datasets. The sequences are those shown in Figure 1, plus *Homo sapiens* (accession no. X84694), *Bos taurus* (L38996), *A. suum* (EF-Tu1, AB211994; EF-Tu2, AB212082), *S. cerevisiae* (K00428) and *A. thaliana* (X89227). Dotted lines show the tRNA specificity of each EF-Tu.

Although determination of the tertiary structure will be necessary to clarify the tRNA-recognition mechanism of *T. britovi* EF-Tu1, the following mechanism is suggested by the present and previous studies. *T. britovi* EF-Tu1 binds to

cloverleaf tRNAs with a short T arm (Figure 4) but not to canonical cloverleaf tRNAs (Supplementary Figure 1). This specificity is not strange for *T. britovi* EF-Tu1 because *Trichinella* species do not have any canonical cloverleaf

tRNAs (25). Cloverleaf tRNAs with a short T arm do not have the conserved residues present in canonical tRNAs that are responsible for T arm–D arm interactions (40). RNase T₂ digested most of the T-loop and D-loop regions of *T. spiralis* mt tRNA^{Trp} (Figure 2), indicating that the tRNA does not have T arm–D arm interactions. *T. britovi* EF-Tu1 can discriminate between cloverleaf tRNAs having a normal T-arm and a short T-arm because it may recognize a part of the tRNA that is hidden by the T arm–D arm interaction. The C-terminal extension of *T. britovi* EF-Tu1 probably has a role in recognizing T-armless tRNA, similar to the role of the C-terminal extension of *C. elegans* EF-Tu1 (23). That the C-terminal extension of *T. britovi* EF-Tu1 is shorter by 16 residues than that of *C. elegans* EF-Tu1 may explain why *T. britovi* EF-Tu1 can bind to a cloverleaf tRNA with a short T arm whereas *C. elegans* EF-Tu1 cannot (Figure 3F).

The length of the C-terminal extension of EF-Tu is likely to have co-evolved with the length of the T arm of tRNA; the shorter the T arm, the longer the C-terminal extension becomes. In mammalian mitochondria, EF-Tu has an 11 amino acid C-terminal extension (41) that can recognize canonical cloverleaf tRNAs and tRNAs with a short T arm, such as those containing a 4 bp T stem or a 4 nt T loop. In mitochondria of the enoplean nematode *T. britovi*, EF-Tu1, which bears a 41 amino acid C-terminal extension, can bind tRNAs with a short T arm or no T arm. In the chromadorean nematode *C. elegans*, EF-Tu1, which has a 57 amino acid C-terminal extension, can bind only to T-armless tRNAs. No animal mt translation systems known so far contradict this hypothetical rule.

In the mitochondria of both *C. elegans* and *Trichinella*, the only tRNAs for serine are two D-armless tRNAs (7,25). *C. elegans* EF-Tu2 specifically recognizes the serine moiety of Ser-tRNA, and thus it can bind only to tRNA charged with serine (24). As shown in Figure 5, *T. britovi* EF-Tu2 has the same serine specificity, suggesting that this unique recognition mechanism was established at the common ancestor of Chromadorea and Enoplea and likely persists due to the conservation of the secondary structure of two tRNAs^{Ser}, at least in nematodes.

Plants (e.g. *Arabidopsis thaliana*) and fungi (e.g. *Saccharomyces cerevisiae*) have only a single mt EF-Tu, which is closely related to the bacterial EF-Tu (Figure 6), suggesting that mt EF-Tu was highly homologous to the canonical EF-Tu when mitochondria were generated from the ancestral bacteria. It is likely that the mt EF-Tu gene was duplicated after the emergence of the metazoa (Figure 6), and then the two EF-Tu genes co-evolved with different types of truncated tRNAs into distinct forms. However, the mt translation systems of some lineages, such as mammals (bovine, Figure 6), have only a single EF-Tu, which is structurally close to the canonical EF-Tu (41,42). Thus, it is likely that duplication of the EF-Tu gene and the unique evolution of EF-Tus have occurred in some lineage(s), including that of nematodes, but not in others. From a functional standpoint, unique EF-Tu species are not necessary in mammalian mitochondria, which contain only moderately truncated tRNAs. The duplication of the EF-Tu gene and the independent evolution of the duplicated genes probably contributed to the extreme truncation of nematode mt tRNAs.

The evolutionary process from canonical EF-Tu to chromadorean nematode EF-Tus has not been well known. In this study, we clarified the connection between the two EF-Tu species and three types of tRNAs in *Trichinella* spp. Our data suggest that enoplean EF-Tu1 is an evolutionary intermediate between the canonical EF-Tu and the chromadorean nematode EF-Tu1 for T-armless tRNAs. Furthermore, the present study of the *Trichinella* system gives insight into how the division of labor by two EF-Tus in *C. elegans* was established. In *T. britovi*, EF-Tu1 can bind all three of the mt tRNA types present in this organism and can deliver all elongator aminoacyl-tRNAs; it therefore seems that EF-Tu2, which binds only to Ser-tRNAs, is an auxiliary factor in the *T. britovi* mt translation system. The *T. britovi* system thus represents a transition state from the canonical system, which requires only a single EF-Tu, to the *C. elegans* system, which requires two distinct EF-Tus. To understand this co-evolutionary process in detail, it will be necessary to analyze tRNA sequences, EF-Tu sequences and tRNA-recognition specificities of EF-Tu for various metazoan species. Understanding how protein enlargement compensates for RNA truncations will be quite important for considering the transition from RNA world to the ribonucleoprotein world.

SUPPLEMENTARY DATA

Supplementary Data are available at NAR Online.

ACKNOWLEDGEMENTS

We thank Dr A. Sato (University of Tokyo) for *D. melanogaster* mt tRNA^{Cys}, and Prof. Y. Kohara (National Institute of Genetics, Japan) for the cDNA clones. This work was supported by the Kurata Memorial Hitachi Science and Technology Foundation to T. O. and JSPS to Y. W. Funding to pay the Open Access publication charges for this article was provided by JSPS.

Conflict of interest statement. None declared.

REFERENCES

- Boore, J.L. (1999) Animal mitochondrial genomes. *Nucleic Acids Res.*, **27**, 1767–1780.
- Lynch, M., Koskella, B. and Schaack, S. (2006) Mutation pressure and the evolution of organelle genomic architecture. *Science*, **311**, 1727–1730.
- Sprinzl, M. and Vassilenko, K.S. (2005) Compilation of tRNA sequences and sequences of tRNA genes. *Nucleic Acids Res.*, **33**, D139–D140.
- Wolstenholme, D.R. (1992) Animal mitochondrial DNA: structure and evolution. In Wolstenholme, D.R. and Jeon, K.W. (eds), *Mitochondrial Genomes*. Academic Press, NY, pp. 173–216.
- Wolstenholme, D.R., Macfarlane, J.L., Okimoto, R., Clary, D.O. and Wahleithner, J.A. (1987) Bizarre tRNAs inferred from DNA sequences of mitochondrial genomes of nematode worms. *Proc. Natl Acad. Sci USA*, **84**, 1324–1328.
- Okimoto, R. and Wolstenholme, D.R. (1990) A set of tRNAs that lack either the TyC arm or dihydrouridine arm: towards a minimal tRNA adaptor. *EMBO J.*, **9**, 3405–3411.
- Okimoto, R., Macfarlane, J.L., Clary, D.O. and Wolstenholme, D.R. (1992) The mitochondrial genomes of two nematodes, *Caenorhabditis elegans* and *Ascaris suum*. *Genetics*, **130**, 471–498.
- Watanabe, Y., Tsurui, H., Ueda, T., Furushima, R., Takamiya, S., Kita, K., Nishikawa, K. and Watanabe, K. (1994) Primary and higher order

- structures of Nematode (*Ascaris suum*) mitochondrial tRNAs lacking either the T or D stem. *J. Biol. Chem.*, **269**, 22902–22906.
9. Keddie, E.M., Higazi, T. and Unnasch, T.R. (1998) The mitochondrial genome of *Onchocerca volvulus*: sequence, structure and phylogenetic analysis. *Mol. Biochem. Parasitol.*, **95**, 111–127.
 10. Hu, M., Chilton, N.B. and Gasser, R.B. (2002) The mitochondrial genomes of the human hookworms, *Ancylostoma duodenale* and *Necator americanus* (Nematoda: Secernentea). *Int. J. Parasitol.*, **32**, 145–158.
 11. Steinauer, M.L., Nickol, B.B., Broughton, R. and Orti, G. (2005) First sequenced mitochondrial genome from the phylum Acanthocephala (*Leptorhynchoides thecatus*) and its phylogenetic position within Metazoa. *J. Mol. Evol.*, **60**, 706–715.
 12. Le, T.H., Blair, D. and McManus, D.P. (2002) Mitochondrial genomes of parasitic flatworms. *Trends Parasitol.*, **18**, 206–213.
 13. Terrett, J.A., Miles, S. and Thomas, R.H. (1996) Complete DNA sequence of the mitochondrial genome of *Cepaea nemoralis* (Gastropoda: Pulmonata). *J. Mol. Evol.*, **42**, 160–168.
 14. Yamazaki, N., Ueshima, R., Terrett, J.A., Yokobori, S., Kaifu, M., Segawa, R., Kobayashi, T., Numachi, K., Ueda, T., Nishikawa, K. et al. (1997) Evolution of pulmonate gastropod mitochondrial genomes: comparisons of gene organizations of Euhadra, *Cepaea* and *Albinaria* and implications of unusual tRNA secondary structures. *Genetics*, **145**, 749–758.
 15. Noguchi, Y., Endo, K., Tajima, F. and Ueshima, R. (2000) The mitochondrial genome of the brachiopod *Laqueus rubellus*. *Genetics*, **155**, 245–259.
 16. Helfenbein, K.G., Brown, W.M. and Boore, J.L. (2001) The complete mitochondrial genome of the articulate brachiopod *Terebratalia transversa*. *Mol. Biol. Evol.*, **18**, 1734–1744.
 17. Masta, S.E. and Boore, J.L. (2004) The complete mitochondrial genome sequence of the spider *Habronattus oregonensis* reveals rearranged and extremely truncated tRNAs. *Mol. Biol. Evol.*, **21**, 893–902.
 18. Hu, M. and Gasser, R.B. (2006) Mitochondrial genomes of parasitic nematodes—progress and perspectives. *Trends Parasitol.*, **22**, 78–84.
 19. Kim, K.H., Eom, K.S. and Park, J.K. (2006) The complete mitochondrial genome of *Anisakis simplex* (Ascaridida: Nematoda) and phylogenetic implications. *Int. J. Parasitol.*, **36**, 319–328.
 20. Montiel, R., Lucena, M.A., Medeiros, J. and Simoes, N. (2006) The complete mitochondrial genome of the entomopathogenic Nematode *Steinernema carpocapsae*: insights into Nematode mitochondrial DNA evolution and phylogeny. *J. Mol. Evol.*, **62**, 211–225.
 21. Nissen, P., Kjeldgaard, M., Thirup, S., Polekhina, G., Reshetnikova, L., Clark, B. and Nyborg, J. (1995) Crystal structure of the ternary complex of Phe-tRNA^{Phe}, EF-Tu, and a GTP analog. *Science*, **270**, 1464–1472.
 22. Nissen, P., Thirup, S., Kjeldgaard, M. and Nyborg, J. (1999) The crystal structure of Cys-tRNA^{Cys}-EF-Tu-GDPNP reveals general and specific features in the ternary complex and in tRNA. *Structure*, **7**, 143–156.
 23. Ohtsuki, T., Watanabe, Y., Takemoto, C., Kawai, G., Ueda, T., Kita, K., Kojima, S., Kaziro, Y., Nyborg, J. and Watanabe, K. (2001) An ‘elongated’ translation elongation factor Tu for truncated tRNAs in nematode mitochondria. *J. Biol. Chem.*, **276**, 21571–21577.
 24. Ohtsuki, T., Sato, A., Watanabe, Y. and Watanabe, K. (2002) A unique serine-specific elongation factor Tu found in nematode mitochondria. *Nature Struct. Biol.*, **9**, 669–673.
 25. Lavrov, D.V. and Brown, W.M. (2001) *Trichinella spiralis* mtDNA: a nematode mitochondrial genome that encodes a putative ATP8 and normally structured tRNAs and has a gene arrangement relatable to those of coelomate metazoans. *Genetics*, **157**, 621–637.
 26. Inaba, T., Sato, H. and Kamiya, H. (2003) Monoclonal IgA antibody-mediated expulsion of *Trichinella* from the intestine of mice. *Parasitology*, 591–598.
 27. Thompson, J.D., Higgins, D.G. and Gibson, T.J. (1994) CLUSTAL W: improving the sensitivity of progressive multiple sequence alignment through sequence weighting, position-specific gap penalties and weight matrix choice. *Nucleic Acids Res.*, **22**, 4673–4680.
 28. Guindon, S. and Gascuel, O. (2003) A simple, fast, and accurate algorithm to estimate large phylogenies by maximum likelihood. *Syst. Biol.*, **52**, 696–704.
 29. Whelan, S. and Goldman, N. (2001) A general empirical model of protein evolution derived from multiple protein families using a maximum-likelihood approach. *Mol. Biol. Evol.*, **18**, 691–699.
 30. Ota, T. and Nei, M. (1994) Estimation of the number of amino-acid substitutions per site when the substitution rate varies among sites. *J. Mol. Evol.*, **38**, 642–643.
 31. Sakurai, M., Ohtsuki, T. and Watanabe, K. (2005) Modification at position 9 with 1-methyladenosine is crucial for structure and function of nematode mitochondrial tRNAs lacking the entire T-arm. *Nucleic Acids Res.*, **33**, 1653–1661.
 32. Fechter, P., Rudinger, J., Giege, R. and Theobald-Dietrich, A. (1998) Ribozyme processed tRNA transcripts with unfriendly internal promoter for T7 RNA polymerase: production and activity. *FEBS Lett.*, **436**, 99–103.
 33. Shimada, N., Suzuki, T. and Watanabe, K. (2001) Dual mode recognition of two isoacceptor tRNAs by mammalian mitochondrial seryl-tRNA synthetase. *J. Biol. Chem.*, **276**, 46770–46778.
 34. Hohsaka, T., Ashizuka, Y., Murakami, H. and Sisido, M. (1996) Incorporation of nonnatural amino acids into streptavidin through *in vitro* frame-shift suppression. *J. Am. Chem. Soc.*, **118**, 9778–9779.
 35. Heckler, T.G., Chang, L.H., Zama, Y., Naka, T., Chorghade, M.S. and Hecht, S.M. (1984) T4 RNA ligase mediated preparation of novel ‘chemically miscacylated’ tRNA^{Phe}s. *Biochemistry*, **23**, 1468–1473.
 36. Pingoud, A., Urbanke, C., Krauss, G., Peters, F. and Maass, G. (1977) Ternary complex formation between elongation factor Tu, GTP and aminoacyl-tRNA: an equilibrium study. *Eur. J. Biochem.*, **78**, 403–409.
 37. Lavrov, D.V. and Brown, W.M. (2001) *Trichinella spiralis* mtDNA: a nematode mitochondrial genome that encodes a putative ATP8 and normally structured tRNAs and has a gene arrangement relatable to those of coelomate metazoans. *Genetics*, **157**, 621–637.
 38. LaRiviere, F.J., Wolfson, A.D. and Uhlenbeck, O.C. (2001) Uniform binding of aminoacyl-tRNAs to elongation factor Tu by thermodynamic compensation. *Science*, **294**, 165–168.
 39. Gebhardt-Singh, E. and Sprinzl, M. (1986) Ser-tRNAs from bovine mitochondrion form ternary complexes with bacterial elongation factor Tu and GTP. *Nucleic Acids Res.*, **14**, 7175–7188.
 40. Wakita, K., Watanabe, Y., Yokogawa, T., Kumazawa, Y., Nakamura, S., Ueda, T., Watanabe, K. and Nishikawa, K. (1994) Higher-order structure of bovine mitochondrial tRNA^{Phe} lacking the ‘conserved’ GG and T psi CG sequences as inferred by enzymatic and chemical probing. *Nucleic Acids Res.*, **22**, 347–353.
 41. Worriax, V.L., Burkhart, W. and Spremulli, L.L. (1995) Cloning, sequence analysis and expression of mammalian mitochondrial protein synthesis elongation factor Tu. *Biochim. Biophys. Acta*, **1264**, 347–356.
 42. Andersen, G.R., Thirup, S., Spremulli, L.L. and Nyborg, J. (2000) High resolution crystal structure of bovine mitochondrial EF-Tu in complex with GDP. *J. Mol. Biol.*, **297**, 421–436.
 43. Lewis, D.L., Farr, C.L. and Kaguni, L.S. (1995) *Drosophila melanogaster* mitochondrial DNA: completion of the nucleotide sequence and evolutionary comparisons. *Insect. Mol. Biol.*, **4**, 263–278.