

Operation of an Electronic Nose Aboard the Space Shuttle and Directions for Research for a Second Generation Device

M. A. Ryan, M. L. Homer, H. Zhou, K. S. Mannatt, V. S. Ryan and S. P. Jackson

Jet Propulsion Laboratory, California Institute of Technology
Pasadena CA 91109

ABSTRACT

A flight experiment to test the operation of an Electronic Nose developed and built at JPL and Caltech was done aboard STS-95 in October-November, 1998. This ENose uses conductometric sensors made of insulating polymer-carbon composite films; it has a volume of 1.7 liters, weighs 1.4 kg including the operating computer and operates on 1.5 W average power. In the flight experiment, the ENose was operated continuously for 6 days and recorded the sensors' response to changes in air in the mid-deck of the orbiter. The ENose had been trained to identify and quantify ten common contaminants at the 24-hour Spacecraft Maximum Allowable Concentration (SMAC) level. Most SMACs are on the order of 10-100 ppm. The experiment was controlled by collecting air samples daily and analyzing them using standard analytical techniques after the flight. The device is microgravity insensitive.

INTRODUCTION

The ability to monitor the constituents of the breathing air in a closed chamber in which air is recycled is important to NASA for use in closed environments such as the space shuttle, the space station, and planned human habitats on Mars or the Moon. Air quality from the space shuttle is now determined on the ground after a flight by collecting samples and analyzing them in laboratory analytical instruments such as a gas chromatograph-mass spectrometer (GC-MS). For long duration space habitation, it will be necessary to monitor the breathing air continuously without major investment of crew time. Air must be monitored for the presence of contaminants at levels which have the potential to be harmful to crew health. These levels are defined as Spacecraft Maximum Allowable Concentrations (SMACs) for 1-hour, 1-day, and 1-week periods. Generally, the 1-day SMACs are single or fractional parts-per-million.

At present, the best real time, broad band air quality monitor available in space habitats is the human

nose. It is limited by human factors such as fatigue, exposure to toxins, and inability to detect some compounds. The JPL Electronic Nose (ENose) was developed at JPL in collaboration with Caltech [1-4] to provide air quality monitoring which is not full constituent analysis but is more than a simple alarm. The ENose will monitor the quality of recycled air by monitoring and identifying changes; it is primarily an event monitor which will provide notification of the presence of potentially dangerous substances from spills and leaks with a minimum of crew interaction.

Most existing chemical sensors are designed to detect specific molecules. Array-based sensing uses non-specific sensors in which the pattern and magnitude of response are used to identify and quantify the presence of contaminants. Array-based sensors are based on a biological model of "sniffing", detecting changes in the composition of the environment, and can be trained to detect new patterns.

An electronic nose is such an array of non-specific chemical sensors, controlled and analyzed electronically, which mimics the action of the mammalian nose by recognizing patterns of response to vapors. The sensors used in the device discussed here are conductometric chemical sensors which change resistance when the composition of its environment changes. The sensors are not specific to any one vapor; it is in the use of an array of sensors, each of which responds differently, that gases and gas mixtures can be identified by the pattern of response of the array. Electronic Noses have been discussed by several authors, and may be applied to environmental monitoring as well as to quality control in such wide fields as food processing and industrial environmental monitoring [6,7].

In the device designed and built for crew habitat air monitoring, a baseline of clean air is established, and deviations from that baseline are recorded as changes in resistance of the sensors. The pattern of distributed response of the sensors is deconvoluted, and

contaminants identified and quantified by using a set of software analysis routines developed for this purpose. The overall goal of the program at JPL/Caltech has been the development of a miniature sensor which may be used to monitor the breathing air in the International Space Station, and which may be coordinated with the environmental control system to solve air quality problems without crew intervention.

The JPL ENose uses the conductometric polymer and carbon sensing media developed at Caltech. This device was built and used in an experiment on the space shuttle in which air in the shuttle mid-deck (crew quarters) was monitored continuously for 6 days and the data stored in memory. The data were analyzed after the landing and compared with independent analysis of air samples which had been taken daily during the ENose operation.

The ENose flight experiment on STS-95 (October, 1998) was designed to monitor the air for the presence of ten compounds at or above the 1-hour SMACs for each compound. The ten compounds and their SMACs are listed in Table 1. These compounds were selected based on their having been previously found in analysis of shuttle air. Table 1 also lists the detection limit for each target compound at the time of the flight in the device used in the flight experiment.

THE ELECTRONIC NOSE

The ENose prototype developed and built at JPL has the dimensions 18.5 cm x 11.5 cm x 8 cm (1700 cm³). It weighs 1.4 kg with the control computer, and uses 1.5 W average power and 3 W peak power. The device is controlled by an HP200-LX palm-top computer. Data are collected through a circuit designed for the purpose and stored in flash memory in the HP200LX. A sketch of the ENose set-up is shown in Figure 1. This device was not optimized for minimum mass and volume; experiments in the mid-deck must be contained in space-qualified containers. The container was the majority of the mass in the device and determined the volume.

Sensors The sensors in the ENose are polymer films which have been loaded with a conductive medium, in this case carbon black. A baseline resistance of each film is established; as the constituents in the air change, the films swell or contract in response to the new composition of the air, and the resistance changes. In the JPL ENose, sensing films were deposited on co-fired ceramic substrates which were provided with eight Au-Pd electrode sets. A sketch of the sensor substrate is shown in Figure 2.

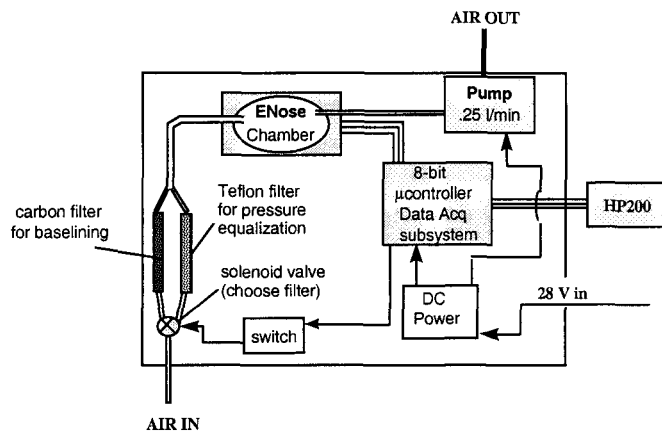

Figure 1: Sketch of ENose flight experiment device

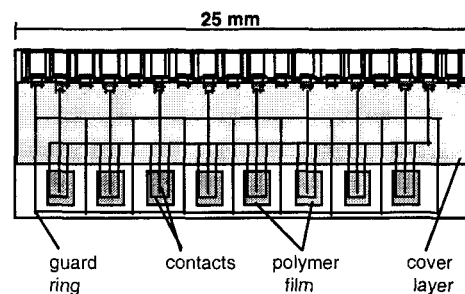

Figure 2: Sketch of the ceramic substrate chip containing eight sensors

The polymers used in the ENose flight experiment were selected by statistical analysis of responses of these films to the target compounds. Data for the statistical analysis were provided by Caltech. The polymers used in the STS-95 flight experiment were:

1. Poly(2, 4, 6-tribromostyrene), 66%
2. Poly(4-vinylphenol)
3. Poly(ethylene oxide)
4. Polyamide resin
5. Cellulose triacetate
6. Poly(2-hydroxyethyl methacrylate)
7. Vinyl alcohol/vinyl butyral, 20/80
8. Poly(caprolactone)
9. Poly(vinylchloride-co-vinyl acetate)
10. Poly(vinyl chloride-co-vinyl acetate) 90/10
11. Poly(vinyl acetate)
12. Poly(N -vinylpyrrolidone)
13. Styrene/isoprene, 14/86 ABA Block copolymer
14. Poly(vinyl stearate)
15. Methyl vinyl ether/ maleic acid 50/50 copolymer
16. Hydroxypropyl methyl cellulose, 10/30

Table 1: Target compounds for electronic nose shuttle experiment and JPL limits of detection.

Compound	Detected on shuttle (ppm) ^[7]	SMAC (ppm) ^[9, 10] 1hr	JPL Detection Limit (ppm)
alcohols			
methanol	< 1	30	5
ethanol	.5 - 5	2000	50
2-propanol	.4 - 4	400	50
ammonia	0	30	20
benzene	< .1	10	10
formaldehyde	0	.4	15
Freon 113	.1 - 1	50	20
indole	0	1	0.03
methane	1 - 10	5300	3000
toluene	.4 - 4	16	15

Protocols for depositing these polymers have been previously published [3,4]. Because most of the polymer film resistances are very sensitive to changes in temperature [11], heaters were included on the back of substrates to provide a constant temperature environment.

Mechanical Design To monitor air quality, flowing air (.25 L/min) is pumped from the surroundings into the sensor chamber of the ENose using a Thomas model X-400 miniature diaphragm pump. The air is directed either through an activated charcoal filter, put in line to provide clean air baseline data, or through a dummy Teflon bead filter, put in line to provide a pressure drop similar to the charcoal filter. Solenoid valves are programmed to open the path to the charcoal filter and provide 15 minutes of clean air flow every 3.5 hours; otherwise, the air is directed through the Teflon bead filter. Air then enters the glass enclosed sensor head chamber where resistance is measured.

Data Acquisition The air is monitored by measuring the sensor voltage at a known, provided current and converting it to resistance. Data acquisition and device control are accomplished using a PIC 16C74A microcontroller. The Hewlett Packard HP 200 LX palm top computer is programmed to direct the microcontroller to open or close the solenoid valve which controls access to the charcoal or Teflon filter and to record sensor resistance. Typical resistance change for 10-50 ppm of contaminant is on the order of 2×10^{-4} (200 ppm resistance change), and may be as small as 1×10^{-5} .

The resistance measurement circuitry designed for the ENose has been described previously [3 - 5]. It is designed to allow the measurement of film resistance changes as 1 in 10^5 , to eliminate cross talk between sensors, and to minimize pin count.

Data Analysis Data analysis for this experiment were done after the flight, using software developed for the purpose. Data analysis development for this experiment focused on development of a method that can correctly identify and accurately quantify a gas event off-line, of single or mixed gases. The routines developed will be modified to provide real-time or quasi-real time analysis in the second phase of this development program.

Data analysis is intended to identify and quantify compounds on the target list at the 1 hour SMAC level. Laboratory tests show 80 - 90% accuracy in identification and quantification of single contaminants at the +/- 50% level. This degree of quantification is sufficient for toxicological purposes, as toxic levels are not known with greater certainty. Mixtures of two or three compounds on the list can also be identified and quantified, with somewhat lower confidence. Events caused by compounds not in the training sets or from mixtures of several target compounds are classified as unknown.

The data analysis routines developed have previously been discussed in detail [5]. Briefly, analysis included several steps. Upon receipt of the data, which are stored as Resistance vs. Time, high and low frequency noise are removed by filtering. High frequency noise is largely caused by the responses of the sensing films. Low frequency noise appears in the data as baseline drift, and is largely caused by humidity, temperature and pressure changes in the monitored atmosphere. Baseline drift which is not removed by high or low frequency filters is removed by constructing a piece-wise baseline from the signals taken during the baselining (clean, filtered air) cycle and subtracting it from the data.

Once the baseline of the data is treated, events are identified by the software and patterns for each event generated for use in the pattern recognition routine.

Because the responses of the array are not linear outside of relatively small concentration ranges, the technique used in this step is the Levenberg-Marquardt Non-linear Least Squares Method (LM-NLS) [12].

FLIGHT EXPERIMENT

Design The ENose flight experiment was designed to provide continuous (*i.e.* 2 points a minute) monitoring of the air in the mid-deck of the orbiter. The ENose response was recorded over 6 days. In order to confirm that the ENose was operating, a crew member would check the operating LEDs on the side of the unit daily to determine that the unit was operating and not in a reference cycle, collect a daily air sample in a Grab Sample Container (GSC), and provide a daily marker by exposing a 2-propanol wipe to the unit. During a ground experiment done in 1997, it was found that the recycled air was very clean and there were very few events [3]. The 2-propanol wipe event was created in order to confirm that the device was working.

After the flight the GSC air samples were returned to Johnson Space Center (JSC) for post-flight analysis using GC-MS, and the ENose unit was returned to JPL. The monitoring data saved in the ENose were analyzed using the software routines developed, and the unit was calibrated to confirm that the sensor responses had not changed. After both JSC and JPL analyzed the data, the two teams met for a data review.

Results Observation of the Resistance vs. Time data that were returned from STS-95 showed that there were several gas events in addition to the daily marker. The daily marker had been added to the experiment so that operation of the device over the entire period could be confirmed. The initial analysis selected the daily markers and identified them as either 2-propanol or 2-propanol plus a humidity change. These identifications were confirmed by comparison of crew log times with the time of the event in the data.

Software analysis identifies all events which were not propanol wipe events as humidity changes. Most of those changes can be well correlated with the humidity changes recorded by the independent humidity measurements provided to JPL by JSC. The events are not completely correlated in time because the humidity sensor was located on the stairway between the mid-deck and the flight deck, and the ENose was located in the mid-deck locker area near the air revitalization system intake. Those events identified as humidity changes but not correlated with cabin humidity change are likely to be caused by local humidity changes; that is, changes in humidity near the ENose which were not sufficient to cause a measurable change in cabin humidity. Figure 3 shows the correlation of cabin humidity with ENose response in several cases. There are visible dips in the traces at times 306.78, 306.87, and 309.40. These dips are the changes in air composition,

and thus resistance, during the baselining cycle, when air is directed through the charcoal filter. Piecewise baseline fitting is based on the resistance during the baselining cycle.

Figure 4 shows the similarity between the pattern for particular events in Figure 4, and compares them with the pattern recorded in training sets for humidity change. Note that the daily marker event from Figure 3, which is a spike seen at time 306.95, is a combination of 2-propanol wipe and humidity change. The marker was made in a time of rising humidity in the cabin. Software analysis of the flight data did not identify any other target compounds, as single gases or as mixtures.

The independent analysis of collected air samples, in which the samples were analyzed at Johnson Space Center by GC-MS, confirmed that no target compounds were found in the daily air samples in concentrations above the ENose detection threshold. There were no compounds that the ENose would have indicated as unidentified events present in the air samples.

The correlation between the ground training and in-flight response patterns for both the 2-propanol wipe and humidity change shows that the operation of the ENose is microgravity insensitive, and thus can be used in a space-based application without further accounting for in microgravity effects.

CONCLUSIONS -- THE FLIGHT EXPERIMENT

While the hope in an experiment such as this one is that there will be several events which test the ability of the device, such events would certainly be anomalous events in the space shuttle environment. It is not surprising that the only changes the ENose saw were humidity changes, and it is because events were not expected that the experiment included the relatively uncontrolled daily marker events. The ENose experiment is judged a success on four counts:

1. the daily marker was identified and quantified
2. humidity events were identified and quantified
3. unremarkable events such as a crew member passing by were not recorded
4. the crew reported no events that would be expected to induce a response in the ENose.

DIRECTIONS FOR THE SECOND GENERATION

Further work with the ENose will take in to account the limitations of the flight experiment. The experiment was controlled to the extent that daily air samples were taken and daily confirmation of the device's operation was made; however, if an event occurred several hours before the air sample was taken,

then the ENose would have been the only detection system. Truly testing the ENose as an incident monitor will require controlled release of target compounds, mixtures of target compounds, and unknowns. This scenario is not a likely one for use in a flight environment, as it will pose a risk to crew health. Thus, the logical next step for testing the ENose as an incident monitor for crew-habitat in spacecraft will be extensive ground testing in a habitat-like environment where controlled releases of contaminants can take place.

Several parts of the current design have been evaluated, and before building a new device to test in a habitat-like environment, modifications will be considered.

Sensors The number of sensors in the Second Generation ENose will remain at 32. The number of polymers may be expanded beyond 16 in order to make groups of polymers which have been selected for response to particular classes of compounds. A model of polymer-analyte interaction will be developed in cooperation with Cyrano Sciences, Inc., in order to select the polymer suite with the analyte suite in mind. This type of selection may result in using some subset of the 32 sensors for various patterns.

It is possible that the use of carbon as the conductive medium is responsible for the non-linearity of responses at low concentrations. The use of metals as the conductive medium is underway. It has been found that alcohols and ketones desorb from metals more rapidly than they do from carbon.

Data Acquisition Current research in data acquisition is investigating the use of frequency dependent methods for data acquisition. AC methods are generally more sensitive than DC methods of measurements. AC methods may be expected to allow increased sensitivity of the films, and to allow the use of thinner, higher resistance films. High frequency noise found in the First Generation device may be filtered with selected AC frequencies.

Data Analysis The overall approach to data analysis will not be modified in the Second Generation device. The major change will be the addition of real time or quasi-real time analysis. For the flight experiment, data were stored and analyzed after the flight. For experiments in Bioplex, data will be analyzed within several minutes of detection.

In addition to addition of real time analysis, other approaches will be used to improve the accuracy of identification. In cases where compounds cannot be identified by the software, portions of patterns which correspond to particular functional groups will be sampled for a match. Thus, while it may not be possible to identify unexpected compounds, it will be possible to classify them according to molecular structure.

In the flight experiment device, data analysis is performed on the steady state signal from contaminants. For air quality monitoring, using the steady state signal is, in general, acceptable, as a transient will not remain in the environment long enough to do harm. However, there are toxins which can do harm as transients. If desorption time is a function of conductive medium, then it may be possible to use the kinetics of sensor film response for identification and quantification. Several compounds can be identified by the shape of the response curve upon visual inspection of the curve. Quantification of the kinetics of response may enable identification of transients.

Miniaturization The mass and volume of the device built for the flight experiment were determined primarily by the container required for operation in the crew habitat. Having no such constraints for extensive ground testing, the new device will be miniaturized by decreasing the size of the sample chamber and the computer. Without the flight qualified container, the mass will be reduced by at least a factor of 4 and the volume by a factor of 3.

Challenging the ENose Before testing the Second Generation ENose in a habitat, it will be extensively tested in the laboratory. A gas delivery system capable of delivering from fractional to ten thousand parts per million of contaminant in air, with adjustable humidity, will be used to train the ENose to an expanded set of compounds. It will then be tested for its ability to recognize the target compounds in an environmental chamber where temperature and humidity are controlled and contaminant provided by contaminants injected or slowly bled into the chamber. After chamber testing, it will be tested in a habitat-like atmosphere.

NASA is in the process of building a habitat test chamber which will be called Bioplex. This test chamber will be used to test environmental monitoring and controls. The plan for the Second Generation ENose is to test it by continuous operation in Bioplex for periods of up to several weeks. It is expected that some controlled releases will be permitted.

Application NASA's interest in the ENose comes from the need to monitor the crew environment in the International Space Station, where crew members will live for months at a time, and where exchange of air will not be possible. Upon demonstration of the utility of the Second Generation ENose, programs to tie it to the environmental control system will begin. The overall goal is development of an automated environmental monitoring and control system which requires little crew action.

ACKNOWLEDGMENTS

The research reported in this paper was carried out by the Jet Propulsion Laboratory, California Institute of Technology under a contract with the National Aeronautics and Space Administration.

Research was supported by NASA Code UL, Advanced Environmental Monitoring and Control. The authors thank Dr. John James of JSC, the flight experiment co-investigator, and Dr. Thomas Limero of Wyle Laboratories for assistance in manifesting the experiment and for providing the GSC analysis.

REFERENCES

1. M.S. Freund and N.S. Lewis, *Proc. National Academy of Science*, **92**, 2652, (1995).
2. M.C. Lonergan, E.J. Severin, B.J. Doleman, S.A. Beaber, R.H. Grubbs and N.S. Lewis, *Chem. Materials*, **8**, 2298 (1996).
3. M.A. Ryan, M.L. Homer, M.G. Buehler, K.S. Manatt, F. Zee, and J. Graf, *Proceedings of the 27th International Conference on Environmental Systems*, Society of Automotive Engineers, (1997).
4. M.A. Ryan, M.L. Homer, M.G. Buehler, K.S. Manatt, B. Lau, D. Karmon and S. Jackson, *Proceedings of the 28th International Conference on Environmental Systems*, Society of Automotive Engineers, (1998).
5. M.A. Ryan, M.G. Buehler, M.L. Homer, K.S. Mannatt, B. Lau, S. Jackson, and H. Zhou; *Proceedings of the Micro/NanoTechnology 99 Conference*, The Aerospace Corp. (1999).
6. H.V. Shurmer and J.W. Gardner, *Sensors and Actuators*, **B8**, 8, (1992).
7. J.W. Gardner, T.C. Pearce, S. Friel, P.N. Bartlett and N. Blair, *Sensors and Actuators*, **B18-19**, 240, (1994).
8. J.T. James, et al., *Aviation, Space Environ. Med.*, **65**, 851 (1994).
9. *Spacecraft Maximum Allowable Concentrations for Selected Airborne Contaminants*, Vols. 1 & 2, National Academy Press, Washington, DC (1994).
10. *Space Physiology and Medicine*, A.E. Nicagossian, C.L. Hunton & S.L. Pool, eds., Lea and Febiger, Philadelphia (1994).
11. M.G. Buehler and M.A. Ryan. *Proc. SPIE Conf. on Electro-Optical Tech. for Chemical Detection*, (April, 1997).
12. M. Lampton, *Computers in Physics*, **11**, 110 (1997).