

Heterozygosity at the *canarc-1* Locus Can Confer Susceptibility for Narcolepsy: Induction of Cataplexy in Heterozygous Asymptomatic Dogs after Administration of a Combination of Drugs Acting on Monoaminergic and Cholinergic Systems

Emmanuel Mignot,¹ Seiji Nishino,¹ Lewanne Hunt Sharp,¹ Janis Arrigoni,¹ Jerome M. Siegel,² Malcolm S. Reid,¹ Dale M. Edgar,¹ Roland D. Ciaranello,¹ and William C. Dement¹

¹Stanford University Sleep Disorders Center, Palo Alto, California 94304 and ²Sepulveda VAMC and Department of Psychiatry, UCLA Medical Center, Los Angeles, California 90024

Narcolepsy is a genetically determined disorder of sleep characterized by excessive daytime sleepiness and abnormal manifestations of REM sleep that affects both humans and animals. Although its exact pathophysiologic mechanisms remain undetermined, recent experiments have demonstrated that in both humans and canines, susceptibility genes are linked with immune-related genes. A striking difference, however, is that the genes thought to be involved in the human pathology are autosomal dominant, whereas canine narcolepsy in Dobermans is transmitted as a single autosomal recessive gene with full penetrance (*canarc-1*). In this study, we have examined the development of narcoleptic symptoms in homozygous narcoleptic, heterozygous, and control Dobermans. Animals were behaviorally observed until 5 months of age and then treated at weekly intervals with cataplexy-inducing compounds that act on cholinergic or monoaminergic systems (alone and in combination). Our data indicate that cataplexy can be induced in 6-month-old asymptomatic heterozygous animals, but not in control canines, with a combination of drugs that act on the monoaminergic and cholinergic systems. This demonstrates that disease susceptibility may be carried by heterozygosity at the *canarc-1* locus. Our data further suggest that cataplexy, a model of REM sleep atonia, is centrally regulated by a balance of activity between cholinergic and monoaminergic neurons.

[Key words: narcolepsy, cataplexy, REM sleep, cholinergic system, adrenergic system, genetics]

Narcolepsy is a genetically determined disorder characterized by a life-long dysfunction of wake and REM sleep mechanisms (Rechtschaffen and Dement, 1967; Guilleminault et al., 1976; Aldrich, 1992). The main symptoms are constant sleepiness and REM-related attacks of loss of motor tone (cataplexy, sleep paralysis) or dreamlike experiences (hypnagogic hallucinations).

The pathophysiologic mechanisms underlying narcolepsy are still unknown.

The human disorder is a multifactorial and heterogeneous disorder of which at least 2 etiological forms have been identified. Human leucocyte antigen (HLA) DRw15, Dw2, DQw6 (DQw1) (DQB1-0602)-positive narcolepsy is the most frequent form of the syndrome (Honda et al., 1983; Matsuki et al., 1992), in which patients require one or several environmental factors and other genes in addition to DQw6 to express symptoms of the disease (Guilleminault et al., 1989; Singh et al., 1990; Mignot et al., 1992). DQB1-0602-negative patients represent only 2–5% of Caucasian patients, and some DQB1-0602-negative patients transmit the disease as a single and possibly fully penetrant dominant gene unlinked to the HLA locus (Guilleminault et al., 1989; Singh et al., 1990; Mignot et al., 1992b). In both DQB1-0602-positive and -negative narcolepsy, a careful analysis of multiplex family trees suggests that the non-HLA susceptibility genes involved are more likely to be autosomal dominant than recessive (Guilleminault et al., 1989; Singh et al., 1990; Mignot et al., 1992b).

Canine cataplexy is an animal model that presents clinical and electrophysiological similarities to human narcolepsy (Lucas et al., 1979; Baker and Dement, 1985; Kushida et al., 1985; Mignot et al., 1992a). Like human narcolepsy, canine narcolepsy is not a simple genetic disease in most breeds in which it has been identified (Baker and Dement, 1985; Mignot et al., 1992a); however, in Dobermans and Labradors, the disease is transmitted as a single autosomal recessive trait with full penetrance (*canarc-1*) (Baker and Dement, 1985; Mignot et al., 1992a). Like human narcolepsy, the pathophysiology of canine narcolepsy likely involves the immune system. We have recently demonstrated that *canarc-1* is a non-HLA-related gene genetically linked with a gene with high homology to the human immunoglobulin μ -switch gene (Mignot et al., 1991). To date, however, in both human and canine narcolepsy, there is no clear evidence in favor of autoimmune mediation of the disease (Matsuki et al., 1988; Rubin et al., 1988; Fredrikson et al., 1990). It is hypothesized that *canarc-1* corresponds to one of the non-HLA genes involved in some or all cases of human narcolepsy (Mignot et al., 1991).

REM sleep is a complex behavior associated with EEG cortical desynchronization, generalized motor paralysis, and various intermittent phasic events such as rapid eye movements.

Received Mar. 17, 1992; revised Sept. 8, 1992; accepted Sept. 8, 1992.

We thank Mike Gelb and Foster Olive for editorial support and Pam Hyde for administrative support. The study was supported by Grants NS23724, NS27710, and NS15184 from NIH to W.C.D., MH 39337 to R.D.C. from NIMH, and NS14610 to J.M.S. from VA Medical Services.

Correspondence should be addressed to Emmanuel Mignot, Stanford University Sleep Disorders Center, 701 Welch Road, Suite 2226, Palo Alto, CA 94304.

Copyright © 1993 Society for Neuroscience 0270-6474/93/131057-08\$05.00/0

Since Jouvet's classical transection studies (Jouvet, 1962), REM sleep has been shown to be generated in the pontine brainstem, although the many different physical manifestations of REM sleep no doubt involve many other brain structures (Siegel, 1989).

The neurochemical and neuroanatomical substrates underlying REM sleep are still largely unknown. The difficulty resides in the complexity of REM sleep as a behavior, involving as it does many different physical characteristics, with a number of relays and neurochemical regulations at each step. One of the most successful models for the generation of REM sleep so far developed is the Hobson and McCarley reciprocal activation model (Hobson, 1974; Steriade, 1990). In this model, the neuropharmacological control of REM sleep involves two largely antagonistic systems, the pontine cholinergic (REM "on" cells) and monoaminergic systems (REM "off" cells). This heuristic model integrates most of the pharmacological, neurochemical, and electrophysiological data currently available, although it remains controversial.

The cholinergic systems suspected to be involved in the regulation of REM sleep originate in the pedunculopontine nucleus and laterodorsal tegmentum (cell bodies) and project to the lateral and/or medial pontine reticular formation (Siegel, 1989; Steriade, 1990) and medial medulla (Lai and Siegel, 1990). These cells are thought to be the primary initiator of REM sleep generation since lesions of these cells abolish REM sleep and their activity is mostly evident during this sleep stage (Siegel, 1989). In agreement with this model, injection of cholinergic agonists in the pontine reticular formation induces REM sleep or dissociated features of REM sleep such as muscle atonia (George et al., 1964; Siegel, 1989; Lydic et al., 1991). Similarly, the release of ACh in this region has been shown to be enhanced during REM sleep (Kodama et al., 1990; Lydic et al., 1991). Taken together, these results strongly support the notion that pontine cholinergic neurons are involved in most of the features of REM sleep generation.

The evidence for the involvement of brainstem monoaminergic systems in the generation of REM sleep is more uncertain. The firing activities of the serotonergic cells of the raphe magnus and noradrenergic cells of the locus coeruleus are dramatically reduced during REM sleep (REM "off" cells), whereas the activity of dopaminergic neurons (substantia nigra and ventral tegmental area) does not seem to be modified (Miller et al., 1983; Jacobs, 1985). This has been generally interpreted as supporting the preferential involvement of serotonergic and noradrenergic systems over dopaminergic systems in the generation of REM sleep. Furthermore, general pharmacological experiments have shown that decreases in monoaminergic tone usually increase REM sleep, and vice versa (Monti, 1983; Mignot et al., 1990). This suggests that in REM sleep, central cholinergic systems are activated whereas monoaminergic systems are depressed. The anatomical correlate of this monoaminergic activity is much less well established than its cholinergic counterpart. Neither a specific lesion nor a local injection of a pharmacologically active compound has yet elucidated the precise anatomical pathways involved.

Cataplexy, one of the major symptoms of narcolepsy, is usually considered a pathological equivalent of REM sleep atonia. In the past few years, we have used the narcoleptic canine as a pharmacological model to further our understanding of the control of REM sleep atonia. Our results to date demonstrate that, like REM sleep, cataplexy is largely the result of a reciprocal interaction of cholinergic and monoaminergic systems (Mignot et al., 1990). As such, cataplexy can be triggered in affected animals

using cholinomimetic compounds such as cholinesterase inhibitors or drugs that depress monoaminergic tone, such as α_1 antagonists or low doses of α_2 and/or D2 autoreceptor agonists (Mignot et al., 1988, 1990; Nishino et al., 1990, 1991). A noticeable difference between cataplexy and REM sleep control was that the pharmacological control of cataplexy seems to involve more specifically the adrenergic system rather than the serotonergic system (Mignot et al., 1990; Renaud et al., 1991). This could corroborate the hypothesis that the serotonergic system is more specifically involved in the control of phasic REM sleep events, such as pontogeniculate-occipital (PGO) spikes (Simon et al., 1973; Luebke et al., 1992).

In the past few years, we have been systematically examining the development of spontaneous cataplexy in all the Dobermans born in our colony. Animals were observed at biweekly intervals for cataplexy or sleepiness until 5 months of age, and then treated at weekly intervals with previously identified cataplexy-inducing compounds acting on the monoaminergic and cholinergic systems. Animals were treated both with single drugs and with drug combinations. Our results now indicate that although heterozygous animals never show any spontaneous symptoms, they do show unambiguous cataplexy after coadministration of drugs that act on cholinergic and monoaminergic systems. This result supports the involvement of a *canarc-1*-like equivalent in some cases of human narcolepsy where predisposing genes seem to be autosomal dominant rather than recessive (Guilleminault et al., 1989; Singh et al., 1990). It also tends to confirm our hypothesis that cataplexy is the result of a complex interaction between cholinergic and noradrenergic systems.

Materials and Methods

Animals. A total of 10 litters, all born in the Stanford University Department of Animal Laboratory Medicine, were included in this study (Table 1).

Four different types of litters were examined: narcoleptic, where both parents were homozygous for *canarc-1* (two litters, four different parents); heterozygous, where one parent was narcoleptic homozygous for *canarc-1* and the other a control animal (two litters, four different parents); control, where both parents were controls (two litters, three different parents); backcross, where one parent was homozygous and the other heterozygous, thus resulting in a 50:50 segregation of homozygous affected and asymptomatic heterozygous offspring (four litters, four different parents). All parents were carefully selected to avoid any litter effect that could interfere with the results of the study, as shown in Figure 1. A few adult (>3 years of age) control ($n = 3$), heterozygous ($n = 2$), and narcoleptic ($n = 6$) animals were also studied.

All dogs were exposed to a 12:12 hr light/dark cycle and had free access to food between 13:00 and 07:00. Animals were bred naturally or by artificial insemination when the selected bitch came into estrus, as recognized clinically and using vaginal swabs. All offspring born were housed with the mother for the first month after whelping. Litters were then split up into several cages as puppies grew. Animals were housed in individual cages after 4 months of age.

Developmental aspects of spontaneously occurring cataplexy. All animals, with the exception of those born in the first backcross litter (Woody \times Dottie, eight puppies), were first tested at 3–4 weeks of age and thereafter tested every 2 weeks until 5 months of age. In each test, puppies were moved to an experimental room, observed for 10 min for spontaneous cataplexy, and then twice administered the Food-elicited Cataplexy Test (FECT) (Baker and Dement, 1985; Mignot et al., 1988, 1990, 1992a; Nishino et al., 1990, 1991). In narcoleptic dogs, the excitement produced by food often precipitates cataplexy, sometimes followed by REM sleep (Mignot et al., 1992a). In the first two sessions (at 3 and 5 weeks of age), animals were trained for FECTs. They were given 12 pieces of wet canned food by hand and then guided to eat pieces that were arranged in a trail on the floor. After two tests, all pieces of food were placed 30 cm apart on the floor. All animals were then trained to eat one piece of food after the other by themselves.

During the whole test (observation and FECT) the experimenters

(always the same two persons, one handling the animal, the other scoring cataplexy) recorded the number of complete and partial cataplectic attacks. An attack was considered complete when the dog dropped to the floor with head resting on the floor in total hypotonia, and partial in other cases (dropped to the ground on hindquarters, forequarters, or both, but with head above the floor).

Effects of cataplexy-inducing compounds. In the past few years, we have identified a few classes of drugs that can precipitate cataplexy in homozygous narcoleptic animals (Mignot et al., 1988, 1990; Nishino et al., 1990, 1991). These drugs can induce cataplexy even in old narcoleptic animals who usually show cataplexy only rarely (symptom severity decreases with age in narcoleptic Dobermans). Two classes of cataplexy-inducing drugs have been identified: the cholinergic agonists that increase motor activity and cataplexy, and a series of drugs acting on monoaminergic systems that decrease alertness and increase cataplexy. These are, namely, α_1 antagonists and a subset of α_2 agonists and D2 autoreceptor agonists (Mignot et al., 1988, 1990; Nishino et al., 1990, 1991). We believe that these monoaminergic drugs act secondarily through noradrenergic systems since only the presynaptic activation of adrenergic systems, and not serotonergic or dopaminergic systems, suppresses cataplexy (Renaud et al., 1991). In this study, the following prototypic drugs were used: physostigmine (acetylcholinesterase inhibitor; Antilirium®, Forest Pharmaceuticals; 100 $\mu\text{g}/\text{kg}$, i.v.), prazosin (α_1 antagonist; Minipress, 1 and 5 mg, Pfizer Pharmaceuticals, 0.6 mg/kg, p.o.), quinpirole (D2 agonist; Research Biochemical Inc.; 6 $\mu\text{g}/\text{kg}$, i.v.), BHT920 (D2 autoreceptor agonist with α_2 activity; Boehringer Ingelheim; 3 $\mu\text{g}/\text{kg}$, i.v.).

The effects of the cataplexy-inducing compounds were examined in sequence, between 5 and 7 months of age, in the 54 animals born in the nine litters mentioned above (Table 1; all litters but the first backcross litter). A few adult animals (>3 years of age) were also studied using the same protocol, and 16 animals born in two backcross litters (eight narcoleptics and eight heterozygous born in the first Woody \times Dottie and the first Bob \times Molly backcross litters) were examined twice with the same treatment protocol at 5–7 and 18–20 months of age. All of the 54 animals were examined with the same drug protocol with the following exceptions: (1) one litter of narcoleptic animals was not studied for the drug combination prazosin plus physostigmine, and the second combination of physostigmine plus BHT920, and (2) one litter of heterozygous animals was examined with the usual drug protocol followed by the drug combination prazosin plus BHT920 in the final week of testing. Drug challenges were given every week in the following sequence: saline (3.0 cc, 5 min before testing), physostigmine (10 min before testing), prazosin (2 hr before testing), quinpirole (5 min before testing), BHT920 (5 min before testing), saline (5 min before testing; data not shown), physostigmine plus prazosin, physostigmine plus quinpirole, physostigmine plus BHT920, physostigmine plus BHT920. Each animal was behaviorally observed for 5 min, and then pieces of wet food were given by hand to the dogs for 10 min to try to trigger cataplexy (10–50 pieces). The number and the length of complete and partial

Table 1. Litters born and studied

Parents (male \times female)	No. of pups born and studied	No. of affected puppies	
		Expected	Observed
Homozygous narcoleptic litters			
Domino (N) \times Coco (N)	7	7	7
Spike (N) \times Electra (N)	5	5	5
Heterozygous litters			
Kyser (C) \times Chablis (N)	7	0	0
Woody (N) \times Brite (C)	6	0	0
Control litters			
Kyser (C) \times Brite (C)	6	0	0
Kentucky (C) \times Brite (C)	3	0	0
Backcross litters			
Woody (N) \times Dottie (Hz)	8	4	5
Woody (N) \times Dottie (Hz)	9*	4–5	4
Bob (Hz) \times Molly (N)	7	3–4	6
Bob (Hz) \times Molly (N)	4	2	3

N, homozygous narcoleptic animal; Hz, heterozygous animal; C, control animal. * One animal was excluded because of uncertain diagnosis (Mignot et al., 1991). This animal never showed any spontaneous attacks before the drug sessions but showed cataplexy after physostigmine and during follow up control sessions.

cataplectic attacks were recorded throughout the procedure by the same 2 experimenters (one scoring, the other handling the animal). Experimenters knew the genetic status of the animals. This was related to the breeding protocols and time of birth of affected litters, a fact difficult to hide due to the limited research team involved in narcolepsy research at Stanford. Active pharmacological agents also had very obvious effects compared to saline (see below) and rendered blinding unoperative.

Electroencephalogram (EEG), electromyogram (EMG), and electrooculogram (EOG) recordings during spontaneous and drug-induced cataplexy in homozygous narcoleptic and heterozygous animals. Chronic implantation of cortical, orbital, and muscle electrodes was performed in one narcoleptic animal (age 2 years) and one heterozygous animal (age 1 year). Animals were anesthetized using halothane anesthesia after an initial dose of short-acting barbiturates (Biotal®; thioamyl sodium, i.v.). To obtain neck muscle electromyogram (EMG), two multistranded stainless steel wires were inserted deep in the posterior neck muscles. The cortical activity (EEG) was recorded from pairs of small stainless steel screws threaded into the skull, but not penetrating the dura, over

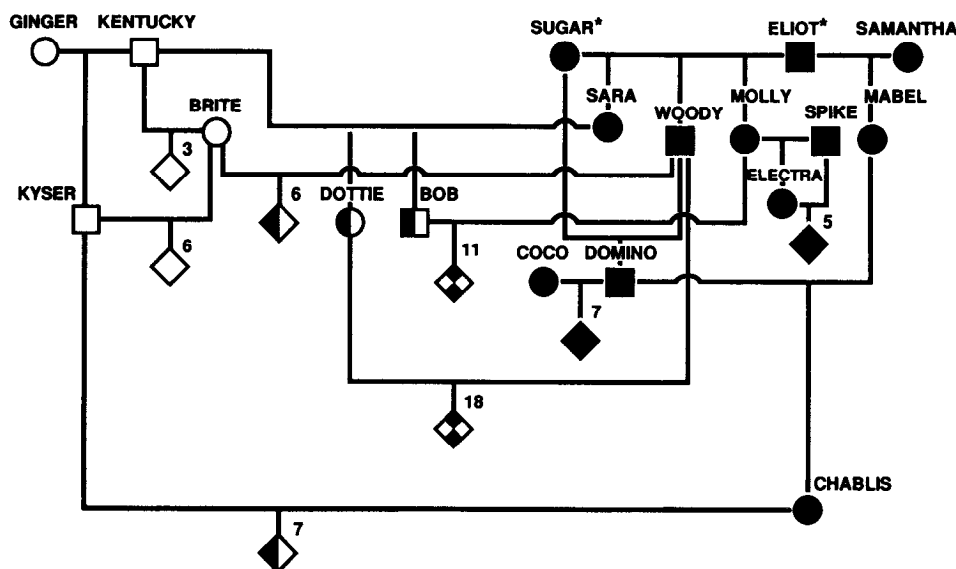

Figure 1. Genetic trees of the litters used for the study. Note that parents were carefully selected to avoid any litter effects. Circles (female) and squares (male) show clinical and *canarc-1* status of individual canines. Solid, half-solid, and open symbols represent, respectively, affected, carrier, and healthy control canines. Diamonds show *canarc-1* status of litters examined in this study; solid, quarter-solid, half-solid, and open symbols represent, respectively, affected, backcross, heterozygous, and healthy litters. Numbers indicate their sizes. *, distantly related by history (pedigree analysis).

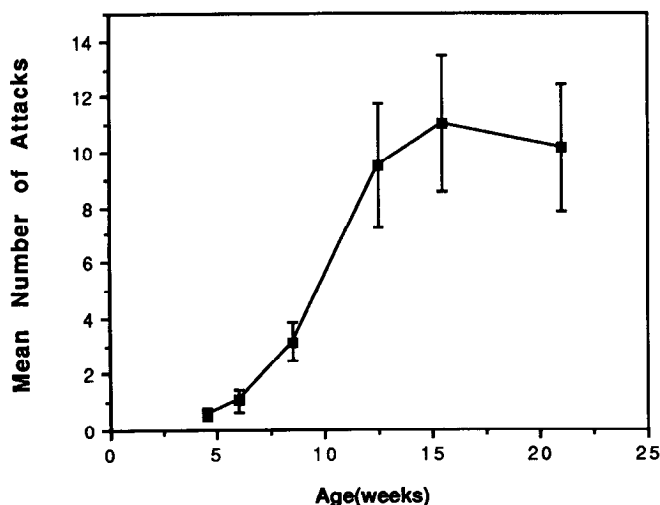

Figure 2. Evolution of cataplexy with age. Data represent the mean \pm SEM of 25 narcoleptic animals born in narcoleptic or backcross litters. Animals were tested using FECT as described in Materials and Methods.

frontal and parietal cortices. Eye movements (EOG) were recorded from pairs of small stainless steel screws threaded into the skull inside the frontal sinuses, in the posterior orbit. Electrode leads were soldered to a Winchester connector and secured to the skull with dental acrylic. Animals were treated with antibiotics prophylactically after surgery. A minimum of 3 weeks was allowed to elapse between the surgery and testing.

The drug studies were always carried out in the afternoon, lights on, on unanesthetized animals in a room that allowed ample movement (3 m \times 3 m), and after previous sessions of adaptation where natural sleep and wakefulness were recorded (lights on and off). The animal was alone in the experimental room but was continuously observed through a one-way mirror window from the adjacent room. The animal was connected to a shielded cable that was joined through the ceiling to an adjacent room where polygraphs were installed. The recordings were carried out by means of an eight-channel EEG/EMG Grass electroencephalograph.

The frontoparietal signals recorded during samples of waking, REM sleep, and non-REM sleep and during the cataplectic attacks (spontaneously occurring or drug induced) were digitized and analyzed using LASSIE[®] on an IBM PC, either on line or from tape recordings (Edgar et al., 1991). Ten-second epochs corresponding to specific stages were

Table 3. Effects of cataplexy-inducing drugs in backcross pure litters

Treatment	Presumed narcoleptics (n = 13)	Presumed heterozygous (n = 7)
Saline	12/13 (160 \pm 43)	0/7
Physostigmine	13/13 (340 \pm 59 ¹)	0/7
Prazosin	13/13 (454 \pm 26 ²)	0/7
Quinpirole	13/13 (471 \pm 21 ²)	0/7
BHT920	13/13 (437 \pm 34 ²)	0/7
Total	13/13	0/7
Physo + prazosin	13/13 (500 \pm 32 ²)	2/7 (0.3 \pm 0.3)
Physo + quinpirole	13/13 (545 \pm 17 ²)	4/7 (5.1 \pm 5.1)
Physo + BHT920	13/13 (551 \pm 9 ²)	4/7 (6.0 \pm 6.0)
Physo + BHT920	13/13 (547 \pm 321 ²)	5/7 (3.4 \pm 3.4)
Total	13/13	5/7

Data represent number of animals showing cataplexy-like symptoms in each group. One backcross dog is not included because of uncertain diagnosis (see Table 1 notes). If applicable, the mean time \pm SEM spent in cataplexy (sec) during 10 min of testing with food is indicated in parentheses.

¹ $p < 0.02$ versus saline.

² $p < 0.01$ versus saline.

pooled for the study. Spectral analysis was performed on 10 epochs of each stage. Data were obtained from one narcoleptic and one heterozygous animal.

Statistics. All comparisons were done using nonparametric paired Wilcoxon tests.

Results

Developmental aspects of spontaneously occurring cataplexy

Spontaneous cataplexy was observed in all "true" narcoleptic animals (born from two homozygous narcoleptic parents) using the protocol described ($n = 12$, two litters), thus confirming that penetrance is very high, if not 100%. Furthermore, unambiguous partial and complete cataplectic attacks could be observed as early as 4 weeks of age in 36% of the narcoleptic animals born in either narcoleptic or backcross litters ($n = 25$; only unambiguous attacks can be diagnosed with certainty at this early age). Cataplexy then increased in severity until 20 weeks (Fig. 2). The mean age of onset where an unambiguous cataplectic attack was first observed was 7.20 ± 0.73 weeks ($n = 25$; range, 4–20 weeks). Cataplexy severity was also observed to be independent of sex (data not shown).

The same protocol of observation was carried out in control and heterozygous animals. No cataplexy-like symptoms or abnormal sleepiness was found during behavioral observation of these animals. It was not possible to distinguish heterozygous and control animals on the basis of simple observation.

Effects of cataplexy-inducing compounds

As expected from our results previously reported from adult homozygous animals (Baker and Dement, 1985; Mignot et al., 1988, 1990; Nishino et al., 1990, 1991), the administration of physostigmine, prazosin, quinpirole, or BHT920 alone enhanced cataplexy in all 5–6-month-old narcoleptic animals born from narcoleptic parents or in backcrosses (Tables 2, 3). Animals showed significantly more frequent and longer cataplectic attacks than after saline administration. Cataplexy occasionally occurred spontaneously, but was more often observed when the animal was stimulated by food, as in the control saline session. In these same animals, administration of a drug combination produces status cataplecticus, most often independent of the

Table 2. Effects of cataplexy-inducing compounds in pure litters

Treatment	Narcoleptics (n = 12)	Heterozygous (n = 13)	Controls (n = 9)
Saline	11/12 (97 \pm 31)	0/13	0/9
Physostigmine	12/12 (285 \pm 45 ¹)	0/13	0/9
Prazosin	12/12 (377 \pm 37 ¹)	0/13	0/9
Quinpirole	12/12 (327 \pm 38 ¹)	0/13	0/9
BHT920	12/12 (288 \pm 33 ¹)	0/13	0/9
Total	12/12	0/13	0/9
Physo + prazosin	5/5 (475 \pm 28 ²)	6/13 (15 \pm 13 ²)	0/9
Physo + quinpirole	12/12 (482 \pm 29 ¹)	8/13 (34 \pm 16 ²)	0/9
Physo + BHT920	12/12 (486 \pm 24 ¹)	9/13 (9 \pm 6 ¹)	0/9
Physo + BHT920	5/5 (552 \pm 99 ²)	9/13 (11 \pm 8 ²)	0/9
Total	12/12	11/13	0/9

Data represent number of animals showing cataplexy-like symptoms in each group. If applicable, the mean time \pm SEM spent in cataplexy (sec) during 10 min of testing with food is indicated in parentheses.

¹ $p < 0.01$ versus saline.

² $p < 0.05$ versus saline.

Table 4. Evolution of the susceptibility of heterozygous animals to the drug combination with age

Treatment	Genetically pure litter (older than 3 years)			18-month-old backcross	
	N (n = 6)	Hz (n = 2)	C (n = 3)	N (n = 8)	Hz (n = 8)
Saline	3/6 (85 ± 49)	0/2	0/3	6/8 (5 ± 3)	0/8
Physo + prazosin	5/5 (337 ± 98 ¹)	0/2	0/3	8/8 (322 ± 73 ²)	0/8
Physo + quinpirole	6/6 (335 ± 85 ¹)	0/2	0/3	4/4 (500 ± 55)	0/5
Physo + BHT920	5/6 (225 ± 112)	0/2	0/3	8/8 (444 ± 34 ²)	2/8 (49 ± 31 ²)
Physo + BHT920	6/6 (275 ± 96)	0/2	0/3	8/8 (362 ± 76 ²)	3/8 (32 ± 20 ²)
Total	6/6	0/2	0/3	8/8	3/8

Data represent number of animals showing cataplexy-like symptoms. If applicable, the mean time ± SEM spent in cataplexy (sec) during 10 min of testing with food is indicated in parentheses. N, narcoleptic animal; Hz = heterozygous animal; C, control animal.

¹ $p < 0.05$ versus saline.

² $p < 0.02$ versus saline.

presentation of food. Animals were in almost continuous cataplexy during the entire test and only occasionally raised their heads. In these cases, time spent in cataplexy approached 70–95% of the 10 min (600 sec) of testing, often with only one continuous attack observed (Tables 2, 3). Animals still reacted to noise, and cataplexy could be interrupted for brief periods of time with strong stimulation.

In 5–6-month-old heterozygous animals, either born from narcoleptic and control parents or in backcrosses (Tables 2, 3), the administration of only one drug (physostigmine, prazosin, quinpirole, BHT920) had no effect. No cataplexy or significant sleepiness was observed in any dogs tested, even during the presentation of food. However, the administration of drug combinations (physostigmine plus prazosin, quinpirole, or BHT920) produced occasional cataplectic attacks, most often after presentation of food. Both complete and partial attacks were observed, and the animal could usually be awakened by a loud noise.

In 5–6-month-old control animals, the administration of neither a single drug nor a drug combination ever produced cataplexy (Tables 2, 3). Animals were behaviorally stimulated by physostigmine, as was the case with heterozygous or narcoleptic animals, and classical side effects such as tremors, diarrhea, and excessive salivation were observed. Similarly, BHT920 and quinpirole produced emesis in control dogs just as it did with narcoleptic or heterozygous animals, but cataplexy was never observed.

The effects of drug combinations were also examined in 16 backcross animals at 18–19 months of age and in a few adult animals (Table 4). It was found that in adult (older than 3 years) heterozygous animals, the drug combination cannot elicit cataplexy. Similarly, in 18-month-old heterozygous animals, only three of eight animals (37.5%) reacted to the compound combination, compared to five of seven (71.5%) when the same animals were 5–6 months old.

EEG, EMG, and EOG recordings during spontaneous and drug-induced cataplexy in homozygous narcoleptic and heterozygous animals

EEG recordings during spontaneous and drug-induced cataplectic episodes were performed to compare cataplectic episodes occurring spontaneously in narcoleptic canines with those occurring after drug combinations in heterozygous dogs. As shown in Figure 3, cataplexy induced by a drug combination in heterozygous animals was similar to that observed spontaneously

in narcoleptic animals. Both forms of cataplexy were associated with a sudden drop in EMG with a low-voltage, fast EEG of mixed amplitude. Spectral analysis was also performed, and no differences were observed (data not shown).

Discussion

In previous studies, we have demonstrated that canine narcolepsy in Dobermans is transmitted as a single autosomal recessive gene with full penetrance (*canarc-1*). Animals born from narcoleptic parents always develop narcolepsy–cataplexy before the age of 5 months, whereas genetically heterozygous animals born from narcoleptic dogs mated with unrelated controls never show spontaneous attacks of cataplexy (Baker and Dement, 1985; Mignot et al., 1992a). Our results obtained with two more crosses of narcoleptic, control, and heterozygous animals confirm these results. All homozygous animals born from narcoleptic parents showed spontaneous, complete cataplectic attacks before 4 months of age. Heterozygous animals were also observed and seemed to behave in all respects identically to normal dogs. These results confirm that the transmission of canine narcolepsy, as defined by the appearance of cataplexy after stimulation by food, is autosomal recessive.

More careful analysis also showed that cataplectic attacks can be observed as early as 3 weeks of age in homozygous animals and that symptom severity increases until 5–6 months of age, at which time it reaches a plateau. We also observed that symptom severity was independent of sex and seems to decrease slowly with old age, as previously reported (Baker and Dement, 1985; Mignot et al., 1992a). It is therefore apparent that the natural history of the disorder in dogs roughly parallels the evolution of the human disorder. Canines reach sexual maturity around 5–6 months of age; likewise, in humans, the development of disease peaks often around puberty (Guilleminault et al., 1976; Aldrich, 1992). Other similarities between human and canine narcolepsy suggested by the results of this study are as follows: (1) human narcolepsy sometimes starts well before the onset of puberty (as early as 6 years of age) (Guilleminault et al., 1976; Aldrich, 1992), while cataplexy was observed in some homozygous animals as early as 3 weeks; (2) symptom severity does not differ between sexes in either dogs or humans (Guilleminault et al., 1976; Aldrich, 1992); and (3) in both humans and canines, cataplexy often improves with age (Sonka et al., 1991). One difference between the canine and human cases is that canines are generally much more affected than human patients in terms of cataplexy; most homozygous narcoleptic ca-

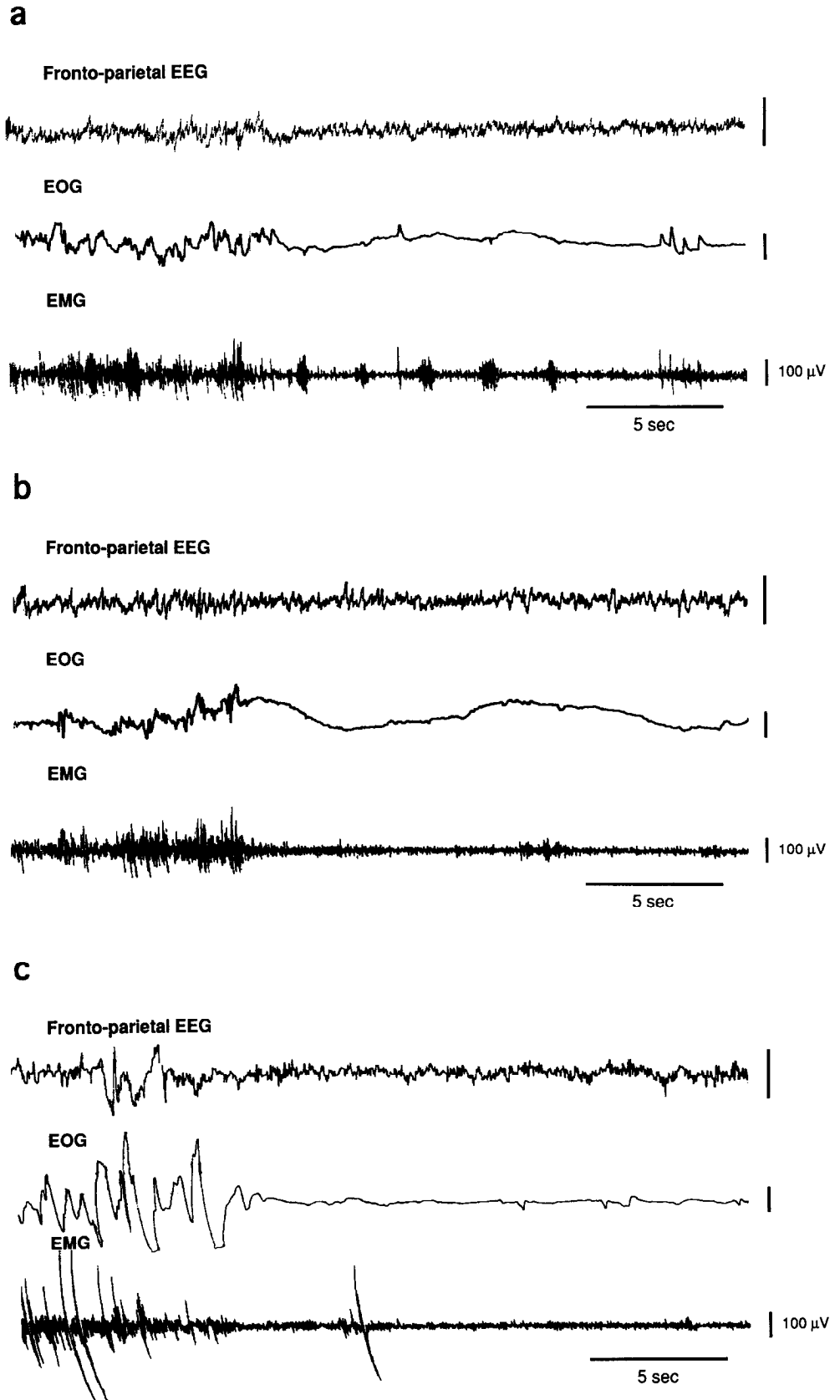

Figure 3. Polygraph samples (fronto-parietal EEG, EOG, and EMG) from narcoleptic animals entering cataplectic attacks. *a*, spontaneous cataplectic attacks in a narcoleptic animal. *b*, cataplectic attack in a narcoleptic animal after injection of physostigmine and BHT920. *c*, cataplectic attack in a heterozygous animal after injection of physostigmine and BHT920. Spectral analysis of EEG was also performed during spontaneous and drug-induced cataplectic attacks and the profiles were found to be identical.

nines exhibit numerous bouts of cataplexy very frequently upon emotional stimulation, whereas most narcoleptic patients rarely present cataplexy. Though some patients experience numerous attacks each day, cataplexy is almost impossible to induce on command in the clinic or in the laboratory.

In this study, we have demonstrated that heterozygosity at the *canarc-1* locus can confer some degree of susceptibility. Heterozygous animals (but not controls) born with one allele of *canarc-1* coming from a diseased parent and carrying normal genes from either of two independent controls (Brite and Kyser; Fig. 1) can present typical cataplectic attacks after injection of a combination of drugs that exacerbates cataplexy in narcoleptic animals. These attacks strongly resemble spontaneous cataplectic attacks clinically, in terms of EEG activity (Fig. 3), and in terms of their developmental time of appearance (Table 4). Interestingly, the active combination of drugs needs to involve a compound acting on the cholinergic system (physostigmine) and a compound acting on the monoaminergic systems (prazosin, quinpirole, or BHT920). One drug given alone was inactive and the combination of two monoaminergic drugs was also without effect (prazosin plus BHT920; $n = 7$ heterozygous animals; data not shown). This result demonstrates that cataplexy is under the synergistic control of cholinergic and monoaminergic systems and argues in favor of similar pharmacological models that have been proposed for the generation of REM sleep (Karczmar et al., 1970; Hobson, 1974). The sites of action of these compounds in the brain, however, remain to be determined and may or may not involve the brainstem monoaminergic and cholinergic systems. A number of drug combinations with strong effects on cataplexy were also identified, and it is possible that these combinations of drugs might have potent REM sleep-inducing effects in humans that could be useful for diagnostic or therapeutic purposes in neuropsychiatry and sleep medicine.

Finally, a genetic predisposition for human narcolepsy has been reported for many years, and the identification of the susceptibility genes involved could open new avenues in the understanding of the physiology of normal sleep. Recent studies have also suggested that the human disorder is a multigenic illness that involves autosomal dominant predisposing genes (Baker and Dement, 1985; Guilleminault et al., 1989). The discovery that heterozygosity at the *canarc-1* locus might predispose to narcolepsy supports the involvement of a *canarc-1* equivalent in some cases of the human disorder.

References

- Aldrich MS (1992) Narcolepsy. *Neurology* 42:34–43.
- Baker TL, Dement WC (1985) Canine narcolepsy-cataplexy syndrome: evidence for an inherited monoaminergic-cholinergic imbalance. In: *Brain mechanisms of sleep* (McGinty DJ, Drucker-Colin R, Morrison A, Parmegiani P, eds), pp 199–233. New York: Raven.
- Edgar DM, Seidel WF, Martin CE, Sayeski PP, Dement WC (1991) Triazolam fails to induce sleep in suprachiasmatic nucleus-lesioned rats. *Neurosci Lett* 125:125–128.
- Fredrikson S, Carlander B, Billiard M, Link H (1990) CSF immune variable in patients with narcolepsy. *Acta Neurol Scand* 81:253–254.
- George R, Haslett WL, Jenden DJ (1964) A cholinergic mechanism in the brainstem reticular formation: induction of paradoxical sleep. *Int J Neuropharmacol* 3:541–552.
- Guilleminault C, Passouant P, Dement WC (1976) *Narcolepsy*. New York: Spectrum.
- Guilleminault C, Mignot E, Grumet FC (1989) Familial patterns of narcolepsy. *Lancet* 335:1376–1379.
- Hobson JA (1974) The cellular basis of sleep control. *Adv Sleep Res* 1:217–250.
- Honda Y, Asaka A, Tanaka Y, Juji T (1983) Discrimination of narcolepsy by using genetic markers and HLA. *Sleep Res* 12:254.
- Jacobs BL (1985) Overview of the activity of brain monoaminergic neurons across the sleep-wake cycle. In: *Sleep: neurotransmitters and neuromodulators* (Wauquier A, Monti JM, Gaillard JM, Radulavacki M, eds), pp 271–285. New York: Raven.
- Jouvet M (1962) Recherches sur les structures nerveuses et les mécanismes responsables des différentes phases du sommeil physiologique. *Arch Ital Biol* 100:125–206.
- Karczmar AG, Longo VG, Scotti de Carolis A (1970) A pharmacological model of paradoxical sleep: the role of cholinergic and monoaminergic systems. *Physiol Behav* 5:175–182.
- Kodama T, Takahashi Y, Honda Y (1990) Enhancement of acetylcholine release during paradoxical sleep in the dorsal tegmental field of the cat brain stem. *Neuroscience Lett* 114:277–282.
- Kushida CA, Baker TL, Dement WC (1985) Electroencephalographic correlates of cataplectic attacks in narcoleptic canines. *Electroencephalogr Clin Neurophysiol* 61:61–71.
- Lai YY, Siegel JM (1990) Cardiovascular and muscle tone changes produced by microinjection of cholinergic and glutaminergic agonists in dorsolateral pons and medial medulla. *Brain Res* 514:27–36.
- Lucas EA, Foutz AS, Dement WC, Miller MM (1979) Sleep cycle organization in narcoleptic and normal dogs. *Physiol Behav* 23:737–743.
- Luebke JI, Greene RW, Semba K, McCarley RW, Kamondi A, Reiner PB (1992) Serotonin hyperpolarizes cholinergic low threshold burst neurons in the rat laterodorsal tegmental nucleus *in vitro*. *Proc Natl Acad Sci USA* 89:743–747.
- Lydic R, Baghdoyan HA, Lorinc Z (1991) Microdialysates of cat pons reveal increased acetylcholine release during state-dependent respiratory depression. *Am J Physiol* 261:R766–R770.
- Matsuki K, Juji T, Honda Y (1988) Immunological features in Japan. In: *HLA and narcolepsy* (Honda Y, Juji T, eds), pp 58–76. New York: Springer.
- Matsuki K, Grumet FC, Lin X, Guilleminault C, Dement WC, Mignot E (1992) DQ rather than DR gene marks susceptibility to narcolepsy. *Lancet* 339:1052.
- Mignot E, Guilleminault C, Bowersox S, Rappaport A, Dement WC (1988) Role of central alpha-1 adrenoceptors in canine narcolepsy. *J Clin Invest* 82:885–894.
- Mignot E, Nishino S, Valtier D, Renaud A, Guilleminault C, Dement WC (1990) Pharmacology of canine narcolepsy. In: *Sleep 90* (Horne J, ed), pp 409–415. Bochum: Pontenagel.
- Mignot E, Wang C, Rattazzi R, Gaiser C, Lovett M, Guilleminault C, Dement WC, Grumet FC (1991) Genetic linkage of autosomal recessive canine narcolepsy with an immunoglobulin μ chain switch-like segment. *Proc Natl Acad Sci USA* 88:3475–3478.
- Mignot E, Guilleminault C, Dement WC, Grumet FC (1992a) Genetically determined animal models of narcolepsy, a disorder of REM sleep. In: *Genetically determined animal models of neurobehavioral dysfunction* (Driscoll P, ed), pp 90–110. Cambridge, MA: Birkhäuser Boston.
- Mignot E, Lin X, Kalil J, George C, Singh S, Billiard M, Montplaisir J, Arrigoni J, Guilleminault C, Dement WC, Grumet FC (1992b) DQB1-0602 (DQw1) is not present in most non-DR2 Caucasian narcoleptics. *Sleep* 15:415–422.
- Miller JD, Farbcr J, Gatz P, Roffwarg H, German DC (1983) Activity of mesencephalic dopamine and nondopamine neurons across stages of sleep and waking in the rat. *Brain Res* 273:133–141.
- Monti JM (1983) Minireview: catecholamines and the sleep wake cycle. *Life Sci* 32:1401–1415.
- Nishino S, Haak L, Sheperd L, Guilleminault C, Sakai T, Dement WC, Mignot E (1990) Effects of central alpha-2 adrenergic compounds on canine narcolepsy, a disorder of rapid eye movement sleep. *J Pharmacol Exp Ther* 253:1146–1152.
- Nishino S, Arrigoni J, Valtier D, Miller J, Guilleminault C, Dement WC, Mignot E (1991) Involvement of dopamine D2-type receptors in the regulation of cataplexy in canine narcolepsy. *J Neurosci* 11:2666–2671.
- Rechtschaffen A, Dement WC (1967) Studies on the relation of narcolepsy, cataplexy, and sleep with low voltage random EEG activity. In: *Sleep and altered states of consciousness, Vol 45* (Association for Research in Nervous and Mental Disease, eds), pp 448–505. Baltimore: William and Wilkins.
- Renaud A, Nishino S, Arrigoni J, Guilleminault C, Mignot E, Dement

- WC (1991) Effects of selective monoamine uptake inhibitors and release enhancers on canine cataplexy. *Sleep Res* 20:76.
- Rubin RL, Hajdukovic RM, Mitler MM (1988) HLA DR2 association with excessive somnolence in narcolepsy does not generalize to sleep apnea and is not accompanied by systemic autoimmune abnormalities. *Clin Immun Immunopathol* 49:149–158.
- Siegel JM (1989) Brainstem mechanisms generating REM sleep. In: *Principles and practice of sleep medicine* (Kryger MH, Roth T, Dement WC, eds), pp 104–120. Philadelphia: Saunders.
- Simon RP, Gherson MD, Brooks DC (1973) The role of the raphe nuclei in the regulation of ponto-geniculo-occipital wave activity. *Brain Res* 58:313–330.
- Singh SM, George CFP, Kryger MH, Jung JH (1990) Genetic heterogeneity in narcolepsy. *Lancet* 335:726–727.
- Sonka K, Tafti M, Billiard M (1991) Narcolepsy and ageing. In: *Sleep and aging* (Smirne S, Franceschi M, Ferini-Strambi L, eds), pp 181–186. Milan: Masson.
- Steriade M (1990) Brainstem control of wakefulness and sleep (Steriade M, McCarley R, eds), p 449. New York: Plenum.