



## THE IMPORTANCE-PERFORMANCE MATRIX ANALYSIS IN PARTIAL LEAST SQUARE STRUCTURAL EQUATION MODELING (PLS-SEM) WITH SMARTPLS 2.0 M3

**Sabri Ahmad**

*Department of Mathematics, Faculty of Science and Technology, Universiti Malaysia Terengganu, Kuala Terengganu, Malaysia*

**Wan Mohamad Asyraf Bin Wan Afthanorhan**

*Department of Mathematics, Faculty of Science and Technology, Universiti Malaysia Terengganu, Kuala Terengganu, Malaysia*

---

### ABSTRACT

*The Important-Performance Matrix Analysis (IPMA) is widely used in analytical technique that yields prescription for the management of customer satisfaction. IPA is a two-dimensional grid based on importance and performance of customer satisfaction. Yet, this paper intend to use the volunteers as a research subject to identify to what extent the strength of the relationship between exogenous and endogenous variable that can be derived. As pedagogical theoretical and past empirical studies, attribute level of performance and importance is relevance and significant. These finding reveals the capabilities of IPA towards a volunteerism program. Using Partial Least Square Structural Equation Modeling with SmartPLS 2.0, the asymmetric relationship importance and performance is provided. Futhermore, it shown that benefits factor is a major importance and performance for establishing Motivation.*

© 2014 Pak Publishing Group. All Rights Reserved.

---

**Keywords:** Importance-performance matrix analysis (IPMA), Motivation, Partial least square structural equation modeling, SmartPLS, Two-dimesion Grid, Volunteerism.

### 1. INTRODUCTION

Importance-performance matrix analysis (IPMA) is useful in extending the findings of the basic PLS-SEM using the latent variables score [1-4]. In the nature of management field, importance-performance matrix analysis is introduced by Martilla and James [5] yield insight into which product or services attributes a firm should be focus on to achieve customer satisfaction. For a specific endogenous construct representing a key target construct in the analysis, IPMA contrast

the structural model total effect (importance) and the average values of the latent variable scores (performance) to highlight significant areas for the improvement of management activities [6]. This analysis has become crucial to identify the critical factors that determine satisfaction and loyalty. However, this paper work make a something different to allow the nature of social science also can be tested to improve the quality and contribution of PLS-SEM.

A basic PLS-SEM analysis identifies the relative importance of constructs in the structural model by extracting the estimation of the direct, indirect, and total relationship. The IPMA extends these PLS-SEM results with another dimension, which includes the actual importance and performance of each constructs. Executing PLS-SEM first requires identifying a target construct. To complete an IPMA of a particular constructs, the total effects and the performance values are needed. The importance of latent constructs for an endogenous target constructs- as analyzed by means of an importance-performance matrix analysis which emerges from these variables total effect [4]. In PLS-SEM, the total effect are derived from a PLS path model estimation.

Thus, the author outlined several objective research that will be implement in this paper to carry out the IPMA using PLS-SEM with SmartPLS 2.0. The first objective of this research paper is to determine the impact of these exogenous variable namely Government, Benefits, Barrier and Challenges on Motivation. In this case, the findings will tell us the significant different of these relationship between exogenous and endogenous variables aside to validate the measurement model is managed to meet the requirement as the assumption provided. Secondly, the author intend to identify to what extend of the importance and performance for each variables provided in a path model. In particular, the findings will reveals the most importance and performance of these variables and the researchers will more better understanding to draw their conclusion and recommendation according their outcomes respectively. All of these objective research should be conducted in a subtopic of findings and of course we can walk through the conclusion, decision, and limitation in this procedure for the last subtopic.

## 2. METHODOLOGY

The total effect of a relationship between two constructs is the sum of all the direct and indirect effects in a structural model. Total effect= direct effect + indirect effect [6]. Next, the performance values of the latent variables in the PLS path model. To make the results comparable across different scales, we use performance scale of 0 to 100, whereby 0 represents the lowest and 100 is the highest performance.

Application of IPMA needs to meet the following requirement: First, all the indicators must have the same direction. We can identify the direction based on the sign provided after we execute the PLS Algorithm in SmartPLS 2.0. Usually, the positive direction is preferred according to our questionnaire developed. Afterwards, inspecting the value provided whereby reflect the observed latent construct that has been capture. A low value represent a bad outcome and a high value represent a good outcome. Second, the outer weight (formative constructs) or outer loadings

(refelctive constructs) that are used must have positive expected and estimated values. If not, the extracted performance value will not be on a scale of 0 to 100.

### 2.1. Sample of the Study

In this study, the data used is the primary source wheby has been distributed for five different places at different time. The questionnaire provided is developed based on the literature review and guided of the expertise on their field. A total of fifty-three items is encomprises for five variables namely Government, Benefits, Barrier, Challenge, and Motivation.

In this instance, the author intend to identify the performance of these variables that prone to give significant impact on the volunteerism discipline. Consequently, factor Motivation is chosen to measure the performance of the particular respondents towards volunteerism program as a research subject. Last but not least, all of these items were measured based on the Likert scale from 1 (Strongly Disagree) to 5 (Strongly Agree) in which is the prior to capture the consent of regression assumption.

### 3. FINDINGS

Our findings should be related on objective research so that we can identify whether our research is sucessful or fail when meet the requirement. In order to accomplish the objective research, the author start to specify the structural model as the basis instrument to pass through the next procedure as suggested. Indeed, our priority is to analyze the Importance-Performance Matrix Analysis (IPMA) but the building of structural model is very closely related on that behaviour method. Now, the author demonstrate the guidelines to perform IPMA with SmartPLS and the interpretation and explanation is also provided to better understanding the purpose and aim our objective research.

Figure-1. Invalid Model

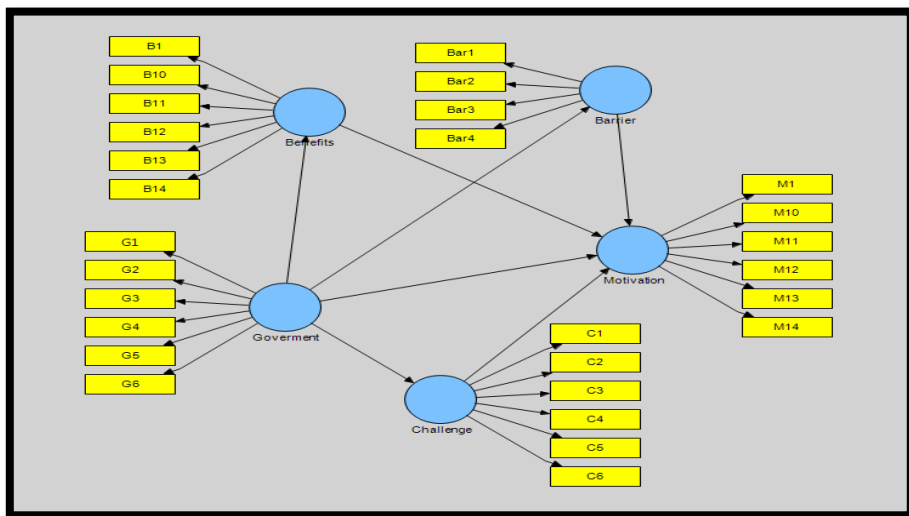

### 3.1. Structural Model After Through Confirmatory Factor Analysis

A key characteristics of the PLS-SEM method is the extraction of latent variables score thereby in default report of SmartPLS 2.0. In order to keeping the substantive theory to apply the advance topics in PLS-SEM, the researchers should ensure the requirement for reflective measurement models is achieved once implement the process of structural model analysis. In this case, the author already ensured execute the application using Pls algorithm to indicate the factor loadings and latent variable correlation provided by PLS-SEM. Paper on the past issue written by the same author for “ *A Comparison of Partial Least Square Structural Equation Modeling and Covariance Based Structural equation Modeling for Confirmatory Factor Analysis*” [7] has been published to provide the better understanding for the first generation analysis to beginner and intermediate level of researchers.

Afterwards, specify the structural model as exactly the proposed model based on our literature review. In this instances, the author apply 5 variables involving three variables considered as mediator variables. These mediator variables were useful when the researchers faces double roles of these variables in a multivariate analysis. Figure 1 shows the invalid structural model after having Confirmatory Factor Analysis (CFA) as the primary in structural equation modeling. On the subsequent analysis, execute the pls algorithm in smartpls to acquire the results created by the help of bootstrapping techniques. Bootstrapping technique is compulsory for whole analysis involving of partial least square structural equation modeling as an aid for nonnormal data or nonparametric analysis. Of this application does not relying on the assumption and has been generalized for asymptotic distribution free to ascertain the analyst make a good interpretation rather than spent for getting the best fit of structural model.

Yet, the researchers should follow a step by step approach on the subsequent analysis of path coefficient to indicate the prediction, direction relationship, main factor, significant relationship and statistics error. Now, we can create the interpretation and explanation based on the given outcome. Researchers should know how to draw the better and good conclusion so that the readers outside understanding our purpose, main objective and contribution of our particular research to share our existing knowledge and information to readers, distributors, scholars, colleagues, professors, authors, analyst and expertise of the particular field.

Now, make sure the rules of thumb structural model evaluation is equivalent with our analysis approach. There are several steps have provided to keep the researchers managed to elaborate the statement and explanation more compact and simplicity.

1. Use bootstrapping to assess the significance of path coefficients. The minimum number of bootstrap sample should be 5,000 considered as double sampling. The number of cases should be equal to the number of data set provided. In studentized t-test, 1.65 (significant level=10%), 1.96 (significant level= 5%), and 2.57 (significant level= 1%). In this case, the author preferred 5% or below to indicate the family pairwise error rate (research hypothesis).

2. PLS-SEM aims at maximising the endogenous construct ( $R^2$  values or square multiple correlation) in the path model. Generally,  $R^2$  values for the endogenous construct can be described as respectively strongly, moderate and weak.  $R^2$  is useful to examine our total variation in structural model, in particular, the highest  $R^2$  values, the highest total variation include in a path model.
3. The effect size  $f^2$  allow assessing an exogenous constructs contribution to an endogenous latent variables. Besides, the predictive relevance is used to obtain cross-validated redundancy measures for each endogenous constructs. Both procedure is mainly to assess the structural model. However, our main objective is to construct an importance-performance matrix analysis (IPMA) which is the extending of the findings of the basic analysis in PLS-SEM outcomes using latent variables scores provided. In this state, it does not mean that we cannot be allow to proceed using on these assessment but we should know what is our main priority, when the appropriate scenario and how to carry on the basic analysis using statistical tools everytime we have to encounter the problems. The best findings is depends on our priority in research objective and how the researchers postulates these applications.

As we can see in Figure 2, the values is shown at every single of latent construct, arrow point, and rectangular shapes. All of these shapes is represent for each variables and the values presented is our findings. Thus, our job is to interpret and find the best way to explain for whole findings and make sure our objective is targeted. Lets see the values enclosed in rectangular shapes for each latent construct and by inspecting through the value, all the values are above 0.60 whereby the CFA is achieved the unidimensionality procedure.

Of the values inside the latent construct (enclosed the round shape) is represented for total variation of the endogenous construct provided ( $R^2$  value or square multiple correlation). Usually, the researchers also intend to examine the statistical power analysis by inspecting through the square multiple correlation. According to Cohen [8], values inside endogenous variables is consider high when upper than 0.80. In addition, we can make the comparison between strength of endogenous construct in a path model. In this case, one of latent construct namely motivation have 0.605 which is classify as moderate group while other endogenous namely Benefits, Barrier, and Challenge is consider as weak group.

**Table-1.** Path Coefficient

	<b>Original Sample</b>	<b>Sample Mean</b>	<b>Standard Deviation</b>	<b>Standard Error</b>	<b>T Statistics</b>
Barrier -> Motivation	0.0391	0.04	0.0334	0.0334	1.1722
Benefits -> Motivation	0.7101	0.7099	0.035	0.035	20.3091
Challenge -> Motivation	0.0478	0.0494	0.033	0.033	1.4471
Government -> Barrier	0.2561	0.262	0.0528	0.0528	4.8515
Government -> Benefits	0.4284	0.4319	0.0532	0.0532	8.0579
Government -> Challenge	0.2497	0.2564	0.0477	0.0477	5.2384
Government -> Motivation	0.0889	0.0882	0.0355	0.0355	2.5054

Figure-2. PLS Algorithm

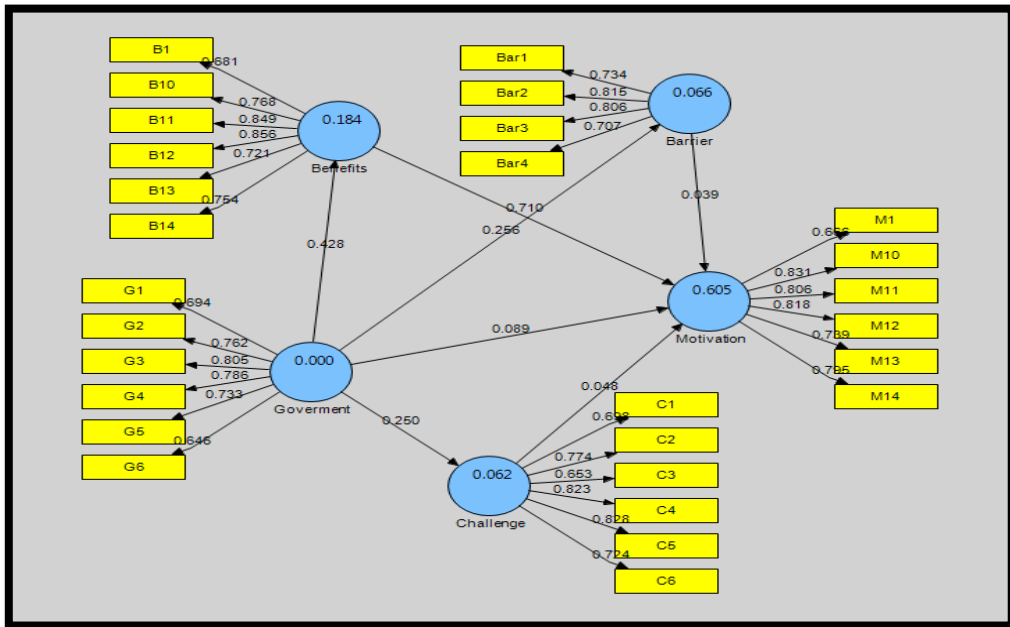

Table 1 present the path coefficient for structural model using SmartPLs 2.0. A total of seven path coefficient between exogenous and endogenous construct are shown regarding on how we specify the structural model earlier. By addressing on original sample directly after running the bootstrapping technique, the result appear different value to indicate the role significant in a structural model. The first part is to scroll down the values in a second column and focus on a highest value which is 0.7101 thereby for benefits on motivation. For indirect effect (mediator variable) groups involving of Barrier, Benefits and Challenge exerting on motivation shows that benefits is the most significant factor to give a high impact on motivation. Instead of relying on indirect effect, the direct path involving of four path coefficient (Government->Barrier, Government->Benefits, Government->Challenge, Government->Motivation), once again benefits enjoyed popularly a most significant factor to accept a high impact from government. One can be conclude that, benefits variable is possible to gain or deter the impact of volunteerism program as a research subject parallel to the theoretical framework.

Next, the author start to test the significant value for each path coefficient regarding on research hypothesis. At the first moment which is Barrier on Motivation present a non-significant value since the t-statistics provided below than 1.96 (significant level= 0.05). Shortly, the null hypothesis is accepted to indicate Barrier does not have a significant impact on Motivation. Secondly, the most impact factor which is benefits on motivation present a high significant when upper than 1.96. In generals, the null hypothesis is rejected and accept hypothesis 1 to indicate Benefits have a significant impact on Motivation. The interpretation is repeated to the next row until the end of column to examine the significant value. Based on our analysis, there are 5 significant values obtained involving of one of the mediator variable (indirect effect) and four of

direct effect. Figure 3 present a structural model after execute the bootstrapping technique to draw a significant values. In addition, Table 2 illustrate the finding of total effect from the default report. Total effect is the sum of direct effect and indirect effect that will be appear as importance in this research. The prior objective of this research to determine the importance and performance of these variables in a path model. Importance-performance matrix analysis (IPMA) is useful in extending the findings of the basic PLS-SEM using the latent variables score [1-4]. The extension build on the PLS-SEM estimate the path model relationship and adds an additional dimension to the analysis that considers the latent variables's average values.

Figure-3. Bootstrapping Technique

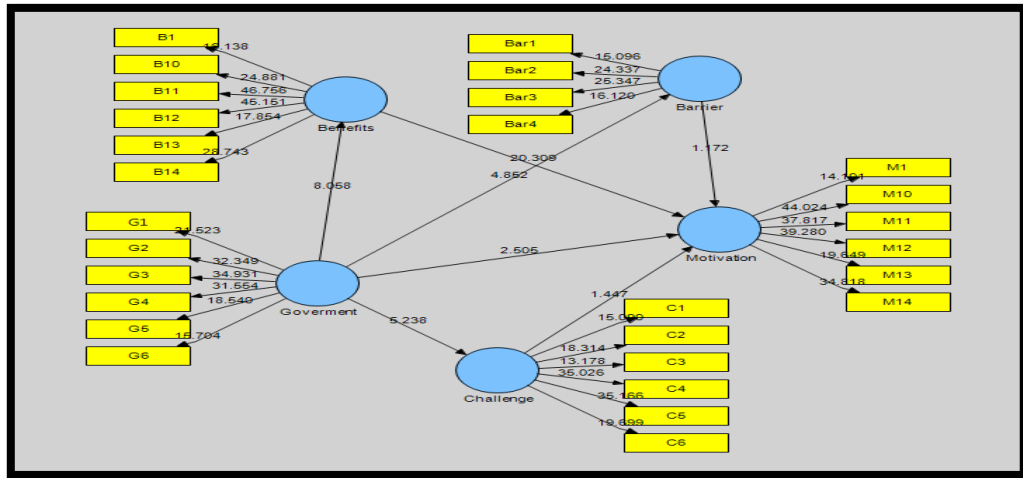

Table-2. Total Effect

	Barrier	Benefits	Challenge	Government	Motivation
Barrier	0	0	0	0	0.0391
Benefits	0	0	0	0	0.7101
Challenge	0	0	0	0	0.0478
Government	0.2561	0.4284	0.2497	0	0.4151
Motivation	0	0	0	0	0

To illustrate the case study, we continue using PLS path model for the same data to achieve our goal to determine the importance and performance of these variables. The goal to conduct IPMA of the key target construct motivation. Before running the analysis, the data need to be rescaled. The rescaling of the latent variables and the index values computation carried out automatically by the SmartPLS software when rescaled indicator data are used. Once we have to determine the value of importance of these variables, we should select of total effect as or result for importance variables. The researchers should click on default report and choose total effect. So, we just have finished for importance of these variables. Based our findings, Benefits is the most importance variable followed by Government variable.

**Table- 3.** Latent Variable Index Value

<b>Variables</b>	<b>LV Index Values</b>
Barrier	3.7943
Benefits	4.3029
Challenge	3.4432
Government	3.8727

Table 3 present the result for latent variable index values in which extract from the default report. Index values is represent for performance of variables after execute the Pls Algorithm. SmartPls is a friendly application when help the researchers nowadays to apply various complicated things to be a simplest way. If the readers does not have this application, they can install these tool at the pls institute after sign up on their website. However, in order to explain how to calculate the outcome of performance, the researchers could find out the mean for each construct that can be performed in various statistical package such as SPSS and other related tools .

In SPSS software, the readers click on transform and choose the compute variable. Then, look at the function the right hand side, scroll down and press on statistical. The function and special variable will appear several procedures, so, double click on mean. Futhermore, select items at our left hand side to import in Numeric Expression. Everytime we import the item in that case, put the semicolon and lastly close the bracket. Once finished to setup the mean, click “Ok” to obtain the result. Before that, rename a new model so that we can find out the compute mean present on a renew name. Afterwards, copy all column of renew name and paste on Microsoft Excel to obtain the sum of the performance of these variables.

In order to avoid an ambiguity explanation of these result, the author compile the result of importance and performance at the Table 4 so that we can illuminate the significant of importance-performance matrix analysis in this research paper. The findings reveal that the most importance variable is benefit followed by Government, Barrier and Challenge while the most performance for this case is also Benefits. One can be conclude that Benefits is the most importance and performance variable for the volunterism as the research subject. This data allow for creating an IPMA representation, as shown in Figure 4 by using spreadsheet applications, such as Microsoft Excel or CALC in OpenOffice.

**Table-4.** IPMA Results

	<b>Importance</b>	<b>Performance</b>
Barrier	3.7943	0.0391
Benefits	4.3029	0.7101
Challenge	3.4432	0.0478
Government	3.8727	0.4151



Figure-4. IPMA Representation of Motivation

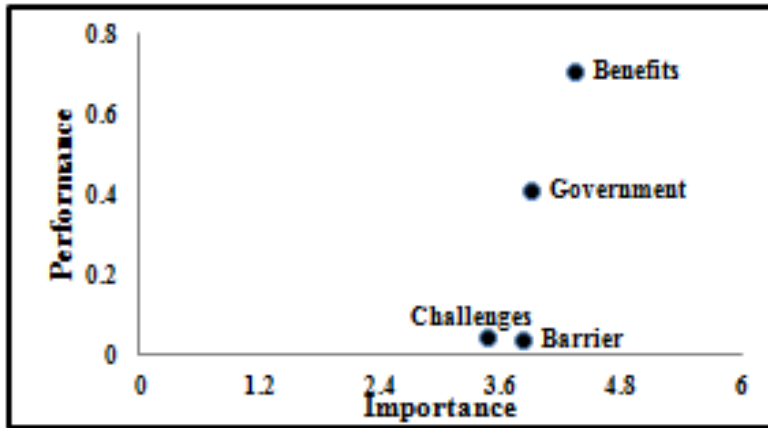

Figure-5. Performance of Motivation

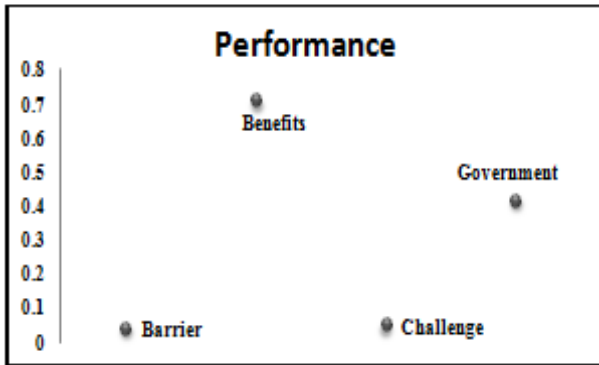
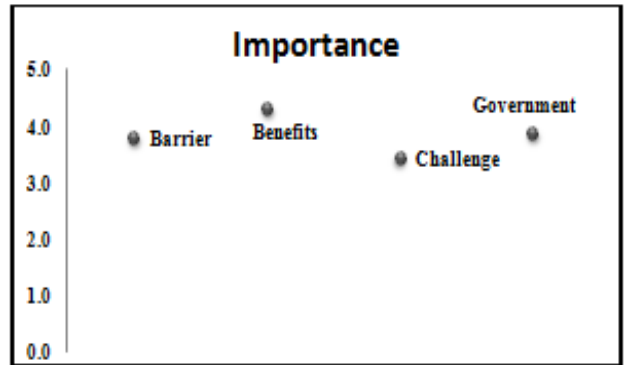

Figure-6. Importance of Motivation



As shown in Figure 4, the IPMA of Motivation reveals that Benefits is of primary importance and performance for establishing Motivation. Challenges, on the other hands, has little relevance because it is low importance even though it has relatively high performance compare to Barrier. Consequently, volunteer activities to improve Motivation should be focus on the Benefits construct. However, one of the variable namely Government seems also has high importance and performance analysis. So, we might can use the Benefits and Government construct for the future research in order to enhance the participation of volunteer to involve the launched activities.

Several authors [9-11] use regression analysis with dummy variables to identify the asymmetric impact of attribute performance on overall satisfaction. In essence, one set of dummy variables is created and used to quantify excitement factors, and another set is created to quantify basic factors. This kind of analysis has become increasingly popular to extend the findings of PLS-SEM analyses. Hock, et al. [2] and Rigdon, et al. [12] present examples of IPMAs in PLS-SEM.

#### 4. CONCLUSION AND RECOMMENDATION

Finally, the researchers and practitioners should draw their conclusion based on their findings coincides with their objective research. In subtopic of findings, the author specify the structural model using SmartPLs according to our literature review. In this case, five variables namely

Motivation, Government, Benefit, Challenge and Barrier has been chosen to carry out for this research paper and at the same time the method has been extended to advanced structural equation modeling to equip the significant and contribution of this case study. For the first part, the researchers should apply the Confirmatory Factor Analysis (CFA) to examine the factor loadings, convergent and discriminant validity. All the requirement is need to achieve so that we can proceed for the next procedure to examine the significant for each endogenous and exogenous constructs.

Previously, the author had explain the purpose of extension of method namely Importance-Performance Matrix Analysis (IPMA). In particular, of this existing model can improve our analysis besides to avoid use the same things that has been tedious since a few decades. Of this paper intends to identify the importance and performance for each exogenous variables on endogenous variable could improve level of strength of our analysis. In the accordance of our findings, factor Benefits is selected as the most importance (relevance) and performance (significant) for the volunteer activities. Thus, we can see the prior of Benefits to provide the better meant to enhance the involvement of youth in volunteerism program. In perpendicular for factor Challenge which is less relevance since having the lower importance which indicate is not a prior for our analysis for the next research. However, the factor Challenges is better than Barrier when the performance (significant) is feasibled. Thus, Challenge still significant in this research and we might can use this factor for the most appropriate analysis that will be conducted. To be conclude that, IPMA is performed to extend our builds modeling of PLS-SEM that has been concurs every researchers and this kind analysis has been enjoyed popularly to provide the better understanding of our contribution of the research paper.

## **5. ACKNOWLEDGEMENT**

Special thanks, tribute and appreciation to all those their names do not appear here who have contributed to the successful completion of this study. Finally, I'm forever indebted to my beloved parents, Mr. Wan Afthanorhan and Mrs. Parhayati who understanding the importance of this work suffered my hectic working hours.

## **6. AUTHOR BIOGRAPHY**

Wan Mohamad Asyraf Bin Wan Afthanorhan is a postgraduate student in mathematical science (statistics) in the Department of Mathematics, University Malaysia Terengganu. He ever holds bachelor in statistics within 3 years in the Faculty of Computer Science and Mathematics, UiTM Kelantan. His main area of consultancy is statistical modeling especially the structural equation modeling (SEM) by using AMOS, SPSS, and SmartPLS. He has been published several articles in his are specialization. He also interested in t-test, independent sample t-test, paired t-test, logistic regression, factor analysis, confirmatory factor analysis, modeling the mediating and moderating effect, bayesian sem, multitrait multimethod, markov chain monte carlo and forecasting.

## REFERENCES

- [1] C. Fornell, M. D. Johnson, E. W. Anderson, J. Cha, and B. E. Bryant, "The American customer satisfaction index: Nature, purpose and findings," *Journal of Marketing*, vol. 60, pp. 7–18, 1996.
- [2] C. Hock, C. M. Ringle, and M. Sarstedt, "Management of multi-purpose stadiums: Importance and performance measurement of service interfaces," *International Journal of Services Technology and Management*, vol. 14, pp. 188-207, 2010.
- [3] L. Gronholdt, A. Martensen, and K. Kristensen, "The relationship between customer satisfaction and loyalty: Cross-industry differences," *Total Quality Management*, vol. 11, pp. 509-514, 2000.
- [4] N. Slack, "The importance-performance matrix as a determinant of improvement priority," *International Journal of Operations & Production Management*, vol. 14, pp. 59-75, 1994.
- [5] J. A. Martilla and J. C. James, "Importance-performance analysis," *Journal of Marketing*, vol. 41, 1977.
- [6] J. F. Hair, C. M. Ringle, and M. Sarstedt, "Partial least squares structural equation modeling: Rigorous applications, better results and higher acceptance," *Long Range Planning*, vol. 46, pp. 1-12, 2013.
- [7] Afthanorhan, "A comparison of partial least square structural equation modeling (PLS-SEM) and covariance based structural equation modeling (CB-SEM) for confirmatory factor analysis," *International Journal Engineering and Science Innovative Technologies (IJESIT)*, vol. 2, p. 8, 2013.
- [8] J. Cohen, *Statistical power analysis for the behavioral sciences*, 2nd ed. Hillsdale, NJ: Erlbaum, 1988.
- [9] E. W. Anderson and V. Mittal, "Strengthening the satisfaction-profit chain," *Journal of Service Research*, vol. 3, pp. 107-120, 2000.
- [10] K. Matzler, E. Sauerwein, and K. Heischmidt, "Importance-performance analysis revisited: The role of the factor structure of customer satisfaction," *The Service Industries Journal*, vol. 23, pp. 112-129, 2003.
- [11] V. Mittal, W. T. Ross, and P. M. Baldasare, "The asymmetric impact of negative and positive attribute-level performance on overall satisfaction and repurchase intentions," *Journal of Marketing*, vol. 62, pp. 33-47, 1998.
- [12] E. E. Rigdon, C. M. Ringle, M. Sarstedt, and S. P. Gudergan, "Assessing heterogeneity in customer satisfaction studies: Across industry similarities and within industry differences," *Advances in International Marketing*, vol. 22, pp. 169-194, 2011.

## BIBLIOGRAPHY

- [1] T. K. Dijkstra and J. Henseler, "Linear indices in nonlinear structural equation models: Best fitting proper indices and other composites," *Quality & Quantity*, vol. 45, pp. 1505-1518, 2011.
- [2] O. Furrer, B. Tjemkes, and J. Henseler, "A model of response strategies in strategic alliances: A PLS analysis of a circumplex structure," *Long Range Planning*, vol. 45, pp. 424-450, 2012.
- [3] S. P. Gudergan, C. M. Ringle, S. Wende, and A. Will, "Confirmatory tetrad analysis in PLS path modeling," *Journal of Business Research*, vol. 61, pp. 1238-1249, 2008.

- [4] J. F. Hair, G. T. M. Hult, C. M. Ringle, and M. Sarstedt, *A primer on partial least squares structural equation modeling (PLS-SEM)*. Thousand Oaks: Sage, 2014.
- [5] J. F. Hair, C. M. Ringle, and M. Sarstedt, "PLS-SEM: Indeed a silver bullet," *Journal of Marketing Theory and Practice*, vol. 18, pp. 139-152, 2011a.
- [6] J. F. Hair, C. M. Ringle, and M. Sarstedt, "The use of partial least squares (PLS) to address marketing management topics: From the special issue guest editors," *Journal of Marketing Theory and Practice*, vol. 18, pp. 135-138, 2011b.
- [7] J. F. Hair, C. M. Ringle, and M. Sarstedt, "Partial least squares: The better approach to structural equation modeling?," *Long Range Planning*, vol. 45, pp. 312-319, 2012.
- [8] J. F. Hair, M. Sarstedt, T. M. Pieper, and C. M. Ringle, "Applications of partial least squares path modeling in management journals: A review of past practices and recommendations for future applications," *Long Range Planning*, vol. 45, pp. 320-340, 2012.
- [9] J. F. Hair, M. Sarstedt, C. M. Ringle, and J. A. Mena, "An assessment of the use of partial least squares structural equation modeling in marketing research," *Journal of the Academy of Marketing Science*, vol. 40, pp. 414-433, 2012.
- [10] K. W. Hansmann and C. M. Ringle, *Strategies for cooperation. Competitive advantage of the cooperatives' networks*. Aachen: Shaker, 2005.
- [11] J. Henseler, "On the convergence of the partial least squares path modeling algorithm," *Computational Statistics*, vol. 25, pp. 107-120, 2010.
- [12] J. Henseler, *PLS-MGA: A non-parametric approach to partial least squares-based multi-group analysis. Challenges at the interface of data analysis, Computer science, and optimization*. Berlin, Heidelberg: Springer, 2012a.
- [13] J. Henseler, "Why generalized structured component analysis is not universally preferable to structural equation modeling," *Journal of the Academy of Marketing Science*, vol. 40, pp. 402-413, 2012b.
- [14] J. Henseler and W. W. Chin, "A comparison of approaches for the analysis of interaction effects between latent variables using partial least squares path modeling," *Structural Equation Modeling*, vol. 17, pp. 82-109, 2010.
- [15] J. Henseler and G. Fassott, *Testing moderating effects in PLS path models: An illustration of available procedures. Handbook of partial least squares: Concepts, methods and applications*. Berlin et al.: Springer, 2010.
- [16] J. Henseler, G. Fassott, T. K. Dijkstra, and B. Wilson, "Analysing quadratic effects of formative constructs by means of variance-based structural equation modelling," *European Journal of Information Systems*, vol. 21, pp. 99-112, 2012.
- [17] J. Henseler, C. M. Ringle, and M. Sarstedt, *Using partial least squares path modeling in international advertising research: Basic concepts and recent issues. Handbook of research in international advertising*: Cheltenham Edward Elgar Publishing, 2012.
- [18] J. Henseler, C. M. Ringle, and R. R. Sinkovics, *the use of partial least squares path modeling in international marketing. Advances in international marketing* vol. 20. Bingley: Emerald, 2009.

- [19] J. Henseler and M. Sarstedt, "Goodness-of-fit indices for partial least squares path modeling," *Computational Statistics*, vol. 28, pp. 565-580, 2013.
- [20] J. Henseler, B. Wilson, O. Götz, and C. Hautvast, "Investigating the moderating role of fit on sports sponsoring and brand equity: A structural model," *International Journal of Sports Marketing and Sponsorship*, vol. 8, pp. 321-329, 2007.
- [21] J. Henseler, B. Wilson, and K. Westberg, "Managers' perceptions of the impact of sport sponsorship on brand equity," *Sport Marketing Quarterly* vol. 20, pp. 7-21, 2011.
- [22] C. Höck, C. M. Ringle, and M. Sarstedt, "Management of multi-purpose stadiums: Importance and performance measurement of service interfaces," *International Journal of Services Technology and Management*, vol. 14, pp. 188-207, 2011.
- [23] M. Höck and C. M. Ringle, "Local strategic networks in the software industry: An empirical analysis of the value continuum," *International Journal of Knowledge Management Studies*, vol. 4, pp. 132-151, 2010.
- [24] O. Kocuyigit and C. M. Ringle, "The impact of brand confusion on sustainable brand satisfaction and private label proneness: A subtle decay of brand equity," *Journal of Brand Management*, vol. 19, pp. 195-212, 2011.
- [25] M. Kurtz, "The asymmetric relationship between attribute-level performance and overall customer satisfaction: A reconsideration of the importance-performance analysis," *Industrial Marketing Management*, vol. 33, pp. 271-277, 2003.
- [26] K. Money, C. Hillenbrand, J. Henseler, and N. Da Camara, "Exploring unanticipated consequences of strategy amongst stakeholder segments: The case of a European revenue service," *Long Range Planning*, vol. 45, pp. 395-423, 2012.
- [27] S. Okazaki, J. A. Castaneda, S. Sanz, and J. Henseler, "Factors affecting mobile diabetes monitoring adoption among physicians: Questionnaire study and path model," *Journal of Medical Internet Research*, vol. 14, p. e183, 2012.
- [28] W. J. Reinartz, M. Haenlein, and J. Henseler, "An empirical comparison of the efficacy of covariance-based and variance-based SEM," *International Journal of Research in Marketing*, vol. 26, pp. 332-344, 2009.
- [29] E. E. Rigdon, C. M. Ringle, and M. Sarstedt, "Structural modeling of heterogeneous data with partial least squares. In N. K. Malhotra (Ed.). Armonk: Sharpe," *Review of Marketing Research*, vol. 7, pp. 255-296, 2010.
- [30] C. Ringle, M. Sarstedt, and L. Zimmermann, "Customer satisfaction with commercial airlines: The role of perceived safety and purpose of travel," *Journal of Marketing Theory and Practice*, vol. 19, pp. 459-472, 2011.
- [31] C. M. Ringle, "[Segmentation for path models and unobserved heterogeneity: The finite mixture partial least squares approach]," 2006.
- [32] A. B. W. A. Wan Mohamad, "A comparison of partial least square structural equation modeling (PLS-SEM) and covariance based structural equation modeling (CB-SEM) for confirmatory factor

- analysis," *International Journal Engineering and Science Innovative Technologies (IJESIT)*, vol. 2, p. 8, 2013.
- [33] A. B. W. A. Wan Mohamad, "Hierarchical component using reflective-formative measurement model in partial least square structural equation modeling (PLS-SEM)," *International Journal of Mathematics and StatisticsInvention (IJMSI)*, vol. 2, p. 17, 2013.
- [34] A. B. W. A. Wan Mohamad and S. Ahmad., "Modelling a high reliability and validity by using confirmatory factor analysis on five latent construct: Volunteerism program," *International Research Journal Advanced Engineer and Scientific Technology (IRJAEST)*, vol. 1, p. 7, 2013.
- [35] A. B. W. A. Wan Mohamad and A. Sabri, "Modelling the multimediator on motivation among youth in higher education institution towards volunteerism program," *Mathematical Theory and Modeling (MTM)*, vol. 3, p. 7, 2013.
- [36] A. B. W. A. Wan Mohamad and A. Sabri, "Modelling-the-multigroup-moderator-mediator-on-motivation-among-youth-in-higher education institution towards volunteerism program," *International Journal of Scientific & Engineering Research (IJSER)* vol. 4, p. 5, 2013.