

Multiphase induction motor drives – a technology status review

E. Levi, R. Bojoi, F. Profumo, H.A. Toliyat and S. Williamson

Abstract: The area of multiphase variable-speed motor drives in general and multiphase induction motor drives in particular has experienced a substantial growth since the beginning of this century. Research has been conducted worldwide and numerous interesting developments have been reported in the literature. An attempt is made to provide a detailed overview of the current state-of-the-art in this area. The elaborated aspects include advantages of multiphase induction machines, modelling of multiphase induction machines, basic vector control and direct torque control schemes and PWM control of multiphase voltage source inverters. The authors also provide a detailed survey of the control strategies for five-phase and asymmetrical six-phase induction motor drives, as well as an overview of the approaches to the design of fault tolerant strategies for post-fault drive operation, and a discussion of multiphase multi-motor drives with single inverter supply. Experimental results, collected from various multiphase induction motor drive laboratory rigs, are also included to facilitate the understanding of the drive operation.

1 Introduction

The first record of a multiphase motor drive, known to the authors, dates back to 1969, when a five-phase voltage source inverter-fed induction motor drive was proposed [1]. During the next 20 years multiphase motor drives have attracted a steady but rather limited attention. The pace started accelerating during the 1990s, but it was not until the beginning of this century that the multiphase motor drives have become a focus of a substantial worldwide attention within the drives research community. This has predominantly resulted from developments in three very specific application areas, namely electric ship propulsion, traction (including electric and hybrid electric vehicles) and the concept of 'more-electric' aircraft. Although the specific reasons for looking at a multiphase motor drive utilisation in these application areas vary to a large extent (as does the specific ac motor type and the power electronic converter topology), the common feature is that utilisation of multiphase motor drives is perceived as offering important advantages when compared to the use of their three-phase counterparts.

The net result of the rapid pace of development in multiphase motor drive area during the last five to six years is that a substantial body of work has been published, rendering the only two available survey papers [2, 3] rather obsolete. An attempt is therefore made in this paper to provide an up-to-date survey of the state-of-the-art in this area.

As the title suggests, the scope of the paper is restricted to multiphase induction motor drives. Nevertheless, whenever and wherever the similarities in the drive control algorithms allow so, appropriate references related to multiphase permanent magnet synchronous and synchronous reluctance machines are included as well.

The approach that the authors have adopted in writing this paper is that simply surveying the references descriptively would be of little value in the era of the world-wide-web and numerous available databases and search engines. All the considerations in this paper are therefore accompanied with illustrations of the relevant drive control schemes and, more importantly, with experimental results (recorded over the years in the authors' laboratories) showing the achievable performance and/or underpinning the relevant theoretical aspects.

2 Characteristics of multiphase induction motors

As all students of electrical engineering are aware, three-phase induction motors will accelerate their loads from rest and will run without producing a twice line-frequency pulsating torque. Machines having more than three phases exhibit the same properties, but those with one or two phases do not. This was one of the clinching arguments that led to the universal adoption of three phases for electrical power systems, more than a century ago. However, increasing numbers of induction motors are not connected directly to three-phase supplies. Instead, they derive their excitation from a power electronic converter, the input stage of which is connected to a three-phase supply. The output stage of the converter and the stator winding of the motor must have the same number of phases, but provided this simple requirement is met, any number of phases may be used. Three is still the common choice, however, not only for the reasons given above, but also because the mass production of three-phase motors for main excitation keeps their unit cost low and standardisation enables motors to be sourced from any manufacturer.

© The Institution of Engineering and Technology 2007

doi:10.1049/iet-epa:20060342

Paper first received 4th September and in revised form 4th December 2006

E. Levi is with the Liverpool John Moores University, School of Engineering, Liverpool, UK

R. Bojoi and F. Profumo are with the Politecnico di Torino, Dipartimento de Ingegneria Elettrica Industriale, Turin, Italy

H.A. Toliyat is with the Department of Electrical Engineering, Texas A&M University, College Station, Texas, USA

S. Williamson is with the School of Electrical and Electronic Engineering, The University of Manchester, Manchester, UK

E-mail: e.levi@ljmu.ac.uk

Despite the above, there has been an upsurge of interest in multiphase machines, that is machines with more than three phases. There are several reasons for this, the principal ones being:

1. The stator excitation in a multiphase machine produces a field with a lower space-harmonic content, so that the efficiency is higher than in a three-phase machine.
2. Multiphase machines have a greater fault tolerance than their three-phase counterparts. If one phase of a three-phase machine becomes open-circuited the machine becomes single-phase. It may continue to run but requires some external means for starting, and must be massively de-rated. If one phase of a 15-phase machine becomes open circuited, it will still self-start and will run with only minimal de-rating.
3. Multiphase machines are less susceptible than their three-phase counterparts to time-harmonic components in the excitation waveform. Such excitation components produce pulsating torques at even multiples of the fundamental excitation frequency.

These three aspects are elaborated further in this section. It is to be noted that another important reason for employing multiphase motor variable-speed drives is the possibility of reducing the required rating of power electronic components for the given motor output power, when compared to a three-phase motor drive, an aspect that becomes of huge significance in high power drives, such as those aimed at electric ship propulsion [4–6]. Utilisation of multiphase motor drives also enables improvement in the noise characteristics, when compared to three-phase motor drives [7], this being a consequence of the properties listed above.

An important property of multiphase machines is that, provided that the stator winding is concentrated rather than distributed, torque production can be enhanced by injection of higher stator current harmonics. This feature, recognised probably for the first time in [8] in relation to induction machines and discussed extensively in [9] in conjunction with seven-phase permanent magnet synchronous and synchronous reluctance motor drives is beyond the scope of this section but is covered in detail in Section 5.2.

Valuable studies related to the properties of multiphase induction machines have been conducted in the early days of the multiphase motor drive development [8, 10]. In more recent times characteristics of multiphase machines have been explored taking a ‘high-level’ (i.e., machine-independent) view [11] and the three aspects of multiphase machines, given in the list above, will therefore be highlighted using the results of [11]. For this purpose the stator current is assumed to consist of a fundamental component, of frequency ω , together with a host of time-harmonic components at integer multiples of ω . The excited $2P$ -pole n -phase stator winding is modelled by blocks of current, which are resolved into rotating harmonic surface current distributions of the form

$$j_s(\theta, t) = \Re e \sum_q \sum_v \sqrt{2} \bar{J}_s^{qv} e^{j(q\omega t - vP\theta)} \quad (1)$$

In (1), q is a positive integer which ranges over all time harmonics produced by the switching of the inverter, and θ is the azimuthal co-ordinate. \bar{J}_s^{qv} is the rms phasor of stator surface current density, which has $2vP$ poles and rotates at a speed of $q\omega/vP$ radians per second with respect to

the stator. \bar{J}_s^{qv} is given by

$$\bar{J}_s^{qv} = \frac{nI_q Z}{\pi d} k_{dv} k_{pv} \quad (2)$$

where I_q is the q th time-harmonic component of phase current, Z is the number of series-connected conductors per phase, and d is the mean air-gap diameter. Coefficients k_{dv} and k_{pv} are the v th-harmonic pitch and distribution factors, respectively. For the ‘block’ representation of currents used in [11], k_{dv} is given by

$$k_{dv} = \sin \frac{v\pi}{2n} / \left(\frac{v\pi}{2n} \right) \quad (3)$$

It is shown in [11] that \bar{J}_s^{qv} is non-zero only for values of v that are related to q and to the phase number n by the expression

$$v = q - 2ni \quad i = 0, \pm 1, \pm 2, \pm 3, \pm 4 \quad (4)$$

Equation (4) contains the basic information about the time and space harmonic fields produced by an n -phase excitation. Substitution of $q = 1, n = 3$ into (2) reveals the well-known harmonics produced by the fundamental component of excitation in a three-phase machine. These have order $v = -5, +7, -11, +13$ and so on. A negative sign indicates a backwards rotating field component. In a 12-phase machine, however, the fundamental frequency excitation produces space-harmonic fields of order $v = -23, +25, -47, +49$. This is summarised in Table 1.

The data presented in Table 1 demonstrate that as the number of phases is increased, so the orders of the mmf harmonics produced by the stator excitation, often referred to as the phase belt harmonics, also increase. The magnitude of these harmonic components is also shown in (3) to vary in inverse proportion to v , so that the increase in pole number is accompanied by a reduction in magnitude.

Values of q other than 1 reveal the field components produced by the time-harmonic currents caused by the inverter switching. Table 2, for example, gives the pole numbers of the harmonic fields produced by the 11th excitation harmonic.

The data presented in Table 2 show how time-harmonic components of excitation current can result in field components that will interact with those produced by the fundamental frequency component of excitation. For example, in a six-phase machine, an 11th time-harmonic component of excitation will produce fields that have the same pole numbers as those produced by the fundamental-frequency component, but which rotate in the opposite direction, resulting in pulsating torques of frequency 12ω .

The claim of improved efficiency may be explored by assuming, in the first instance, sinusoidal excitation. Consider two machines of identical design, other than the fact that their stator coils are connected differently to give different numbers of phases, n_1 and n_2 . If both machines are to develop the same torque at the same speed, then it follows that they will have the same rotor joule loss, the same air-gap field and the same fundamental component of stator current loading, that is they will have the same value of \bar{J}_s^{1P} . As both windings are identical, except for the manner in which their coils are interconnected, (2) implies that

$$I_{n_1} k_{d1}^{n_1} = I_{n_2} k_{d1}^{n_2} \quad (5)$$

Table 1: Harmonic fields produced by the fundamental frequency excitation in multiphase machines for the common phase numbers

Number of phases, n	Number of pairs of poles				
	$i = 0$	$i = 1$	$i = -1$	$i = 2$	$i = -2$
3	$+P$	$-5P$	$+7P$	$-11P$	$+13P$
5	$+P$	$-9P$	$+11P$	$-19P$	$+21P$
6	$+P$	$-11P$	$+13P$	$-23P$	$+25P$
9	$+P$	$-17P$	$+19P$	$-35P$	$+37P$
12	$+P$	$-23P$	$+25P$	$-47P$	$+49P$
15	$+P$	$-29P$	$+31P$	$-59P$	$+61P$

Table 2: Harmonic fields produced by the 11th time-harmonic component of excitation in multi phase machines for the common phase numbers

Number of phases, n	Number of pairs of poles				
	$i = 0$	$i = 1$	$i = -1$	$i = 2$	$i = -2$
3	$+11P$	$+5P$	$+17P$	$-P$	$+23P$
5	$+11P$	$+P$	$+21P$	$-9P$	$+31P$
6	$+11P$	$-P$	$+23P$	$-13P$	$+35P$
9	$+11P$	$-7P$	$+29P$	$-25P$	$+47P$
12	$+11P$	$-13P$	$+35P$	$-37P$	$+59P$
15	$+11P$	$-19P$	$+41P$	$-49P$	$+71P$

The corresponding stator joule losses are therefore inversely proportional to the square of their distribution factors

$$\frac{P_{SCu}^{n_1}}{P_{SCu}^{n_2}} = \left[\frac{I_{n_1}}{I_{n_2}} \right]^2 = \left[\frac{k_{d1}^{n_2}}{k_{d1}^{n_1}} \right]^2 \quad (6)$$

This expression may be used to determine the reduction in stator joule loss that is obtained by using more than three phases. This data is given in Table 3, which shows the reduction in stator joule loss achieved when the number of phases is increased from 3. The data presented in Table 3 show that, at least as far as the fundamental or working field of the machine is concerned, the reduction in loss obtained by increasing the number of phases is relatively modest, and that it rapidly approaches an asymptote. In considering this statement it should be borne in mind that the fundamental rotor joule loss will be unchanged, as will the fundamental air-gap field (and therefore the iron loss). On the other hand, the space harmonic fields produced by the stator mmf, whose pole-pair numbers are given in Table 2, will also produce additional rotor joule loss and iron loss. The use of higher phase numbers increases the pole number of these harmonic components, and thereby reduces their magnitude, and this will reduce the corresponding losses accordingly. The significance of this as a loss reduction mechanism will be highly design-dependant,

Table 3: Reduction in stator joule loss achieved by increasing the number of phases beyond three

Phase number, n	5	6	9	12	15	∞
Stator copper loss reduction (%)	5.6	6.7	7.9	8.3	8.5	8.8

but is not expected to be as important as the stator copper loss reduction given in Table 3.

The same ‘high-level’ model was used in [12] to explore fault tolerance in terms of the loss of a phase. A number of idealising assumptions may be made in relation to strategies on how the remaining un-faulted phases are controlled after the fault. Such assumptions are suited to the purpose in this overview, which is to give an understanding of the issues and orders of magnitudes involved (detailed discussion of practical algorithms for controlling machines with an open-circuited phase is given in Section 7). The following three cases are considered:

Strategy 1: Keep the currents in the remaining un-faulted phases at their pre-fault values, in terms of both magnitude and phase. This reduces the stator joule loss by a factor $(n - 1)/n$.

Strategy 2: Increase the magnitude of the current in each un-faulted phase by a factor $\sqrt{n/(n - 1)}$. This will maintain the stator joule loss at its pre-fault value.

Strategy 3: Increase the magnitude of the current in each un-faulted phase by a factor $n/(n - 1)$. This increases the stator joule loss by a factor $n/(n - 1)$, but maintains the torque and (fundamental) rotor joule loss at their pre-fault value.

The impact of these three strategies depends on both the operating point and on the characteristics of the load torque. The data presented in Table 4 are based on a typical fan or propeller load, with the load torque which varies as the square of the speed. In addition, it is assumed that the motor is operating on the steep part of its torque/speed characteristic so that the torque developed is proportional to slip. The pre-fault slip of the motor is 0.01.

The data presented in Table 4 show that under Strategy 1, the stator loss is reduced, but the consequential reduction in

Table 4: Changes to output power and loss for multiphase machines with one phase open-circuited, assuming a speed-square-law load torque and a pre-fault slip of 0.01

Phase number	Strategy	Post-fault slip	ΔP_{out} (%)	Change in stator loss (%)	Change in rotor loss (%)
6	1	0.01427	-1.29	-16.7	+42.7
	2	0.01195	-0.59	0.0	+19.5
	3	0.01000	0.00	+20.0	0.0
9	1	0.01259	-0.78	-11.1	+25.9
	2	0.01122	-0.37	0.0	+12.2
	3	0.01000	0.00	+12.5	0.0
12	1	0.01186	-0.56	-8.3	+18.6
	2	0.01089	-0.27	0.0	+8.9
	3	0.01000	0.00	+9.1	0.0
15	1	0.01145	-0.44	-6.7	+14.5
	2	0.01070	-0.21	0.0	+7.0
	3	0.01000	0.00	+7.1	0.0

torque causes the slip to increase, along with the rotor loss. Strategy 2, on the other hand, results in a smaller drop in speed than Strategy 1, along with a correspondingly smaller increase in rotor joule loss. Strategy 3 returns the output power and rotor loss to their pre-fault values, but produces an increase in stator joule loss.

The practical implementation of any of these strategies might prove problematic, because of the rating of the power electronic switches and the limitation imposed by the DC link voltage. Furthermore, the data in Table 4 take no account of the additional rotor losses that arise because of the harmonic fields that will be present when the stator is no longer fully balanced. However, the results presented in Table 4 confirm that for each of these idealised strategies, the impact of the loss of a phase diminishes as the phase number increases. For all phase numbers and strategies the loss of output power is negligible, but the site of the extra power loss depends on the strategy adopted.

In this section of the paper an attempt has been made to illuminate those properties of multiphase machines that arise as a consequence of increased phase numbers. The rest of the paper focuses on applications of multiphase induction machines in variable-speed electric motor drives.

3 Control of variable-speed multiphase induction motor drives

3.1 Introduction

Methods of speed control of multiphase induction machines are in principle the same as for three-phase induction machines. Constant V/f control was extensively studied in the early days of the multiphase variable-speed induction motor drive development in conjunction with voltage source inverters operated in the 180° conduction mode [1, 13, 14] and current source inverters with quasi square-wave current output [15–17]. In recent times, the emphasis has shifted to vector control and direct torque control (DTC) since the cost of implementing more sophisticated control algorithms is negligible compared to the cost of multiphase power electronics and the multiphase machine itself (since neither are readily available on the market). This section therefore provides a brief review of basic vector control and DTC schemes for multiphase induction machines. As both rely on machine's

mathematical models, modelling of multiphase induction machines is addressed first.

3.2 Modelling of multiphase induction machines

General theory of electric machines provides sufficient means for dealing with mathematical representation of an induction machine with an arbitrary number of phases on both stator and rotor. It can also effectively model machines with sinusoidally distributed windings and with concentrated windings, where one has to account for the higher spatial harmonics of the magneto-motive force. Probably, the most comprehensive treatment of the modelling procedure at a general level is available in [18]. More recently, detailed modelling of an n -phase induction machine, including the higher spatial harmonics, has been reported in [19], whereas specific case of a five-phase induction machine has been investigated in detail in [20, 21]. Transformations of the phase-variable model are performed using appropriate real or complex matrix transformations, resulting in corresponding real or space vector models of the multiphase machine.

A slightly different approach to the multiphase machine modelling is discussed in [22–24]. It is termed 'vectorial modelling' and it represents a kind of generalisation of the space vector theory, applicable to all types of AC machines. In principle, it leads to the same control schemes for multiphase machines as do the transformations of the general theory of electric machines. This modelling approach is therefore not discussed further on. In what follows, a brief summary of the modelling procedure based on the general theory of electric machines is provided.

An n -phase symmetrical induction machine, such that the spatial displacement between any two consecutive stator phases equals $\alpha = 2\pi/n$, is considered. Both stator and rotor windings are treated as n -phase and it is assumed that the windings are sinusoidally distributed, so that all higher spatial harmonics of the magneto-motive force can be neglected. The phase number n can be either odd or even. It is assumed that, regardless of the phase number, windings are connected in star with a single neutral point. The machine model in original form is transformed using decoupling (Clarke's) transformation matrix [18], which replaces the original sets of n variables with new sets of n variables. Decoupling transformation matrix for an arbitrary phase number n can be given in power invariant

$$\underline{C} = \sqrt{\frac{2}{n}} \begin{bmatrix} \alpha & 1 & \cos \alpha & \cos 2\alpha & \cos 3\alpha & \dots & \cos 3\alpha & \cos 2\alpha & \cos \alpha \\ \beta & 0 & \sin \alpha & \sin 2\alpha & \sin 3\alpha & \dots & -\sin 3\alpha & -\sin 2\alpha & -\sin \alpha \\ x_1 & 1 & \cos 2\alpha & \cos 4\alpha & \cos 6\alpha & \dots & \cos 6\alpha & \cos 4\alpha & \cos 2\alpha \\ y_1 & 0 & \sin 2\alpha & \sin 4\alpha & \sin 6\alpha & \dots & -\sin 6\alpha & -\sin 4\alpha & -\sin 2\alpha \\ x_2 & 1 & \cos 3\alpha & \cos 6\alpha & \cos 9\alpha & \dots & \cos 9\alpha & \cos 6\alpha & \cos 3\alpha \\ y_2 & 0 & \sin 3\alpha & \sin 6\alpha & \sin 9\alpha & \dots & -\sin 9\alpha & -\sin 6\alpha & -\sin 3\alpha \\ \dots & \dots & \dots & \dots & \dots & \dots & \dots & \dots & \dots \\ x_{(n-4)/2} & 1 & \cos\left(\frac{n-2}{2}\alpha\right) & \cos 2\left(\frac{n-2}{2}\alpha\right) & \cos 3\left(\frac{n-2}{2}\alpha\right) & \dots & \cos 3\left(\frac{n-2}{2}\alpha\right) & \cos 2\left(\frac{n-2}{2}\alpha\right) & \cos\left(\frac{n-2}{2}\alpha\right) \\ y_{(n-4)/2} & 0 & \sin\left(\frac{n-2}{2}\alpha\right) & \sin 2\left(\frac{n-2}{2}\alpha\right) & \sin 3\left(\frac{n-2}{2}\alpha\right) & \dots & -\sin 3\left(\frac{n-2}{2}\alpha\right) & -\sin 2\left(\frac{n-2}{2}\alpha\right) & -\sin\left(\frac{n-2}{2}\alpha\right) \\ 0_+ & 1/\sqrt{2} & 1/\sqrt{2} & 1/\sqrt{2} & 1/\sqrt{2} & \dots & 1/\sqrt{2} & 1/\sqrt{2} & 1/\sqrt{2} \\ 0_- & 1/\sqrt{2} & -1/\sqrt{2} & 1/\sqrt{2} & -1/\sqrt{2} & \dots & -1/\sqrt{2} & 1/\sqrt{2} & -1/\sqrt{2} \end{bmatrix}$$

Fig. 1 Clarke's decoupling transformation matrix for a symmetrical n -phase system

form with Fig. 1 where $\alpha = 2\pi/n$. The first two rows of the matrix in Fig. 1 define variables that will lead to fundamental flux and torque production (α - β components; stator to rotor coupling appears only in the equations for α - β components). The last two rows define the two zero-sequence components and the last row of the transformation matrix in Fig. 1 is omitted for all odd phase numbers n . In between, there are $(n-4)/2$ (or $(n-3)/2$ for $n = \text{odd}$) pairs of rows which define $(n-4)/2$ (or $(n-3)/2$ for $n = \text{odd}$) pairs of variables, termed further on x - y components.

Equations for pairs of x - y components are completely decoupled from all the other components and stator to rotor coupling does not appear either [18]. These components do not contribute to torque production when sinusoidal distribution of the flux around the air-gap is assumed. Zero-sequence components does not exist in any star-connected multiphase system without neutral conductor for odd phase numbers, while only 0_- component can exist if the phase number is even. Since rotor winding is short-circuited, neither x - y nor zero-sequence components can exist, and one only needs to consider further on α - β equations of the rotor winding.

As stator to rotor coupling takes place only in α - β equations, rotational transformation is applied only to these two pairs of equations. Its form is identical as for a three-phase machine. Assuming that the machine equations are transformed into an arbitrary frame of reference rotating at angular speed ω_a , the model of an n -phase induction machine with sinusoidal winding distribution is given with

$$\begin{aligned} v_{ds} &= R_s i_{ds} - \omega_a \psi_{qs} + p \psi_{ds} \\ v_{qs} &= R_s i_{qs} + \omega_a \psi_{ds} + p \psi_{qs} \\ v_{x1s} &= R_s i_{x1s} + p \psi_{x1s} \\ v_{y1s} &= R_s i_{y1s} + p \psi_{y1s} \\ v_{x2s} &= R_s i_{x2s} + p \psi_{x2s} \\ v_{y2s} &= R_s i_{y2s} + p \psi_{y2s} \\ &\dots \\ v_{o+s} &= R_s i_{o+s} + p \psi_{o+s} \\ v_{o-s} &= R_s i_{o-s} + p \psi_{o-s} \\ v_{dr} &= 0 = R_r i_{dr} - (\omega_a - \omega) \psi_{qr} + p \psi_{dr} \\ v_{qr} &= 0 = R_r i_{qr} + (\omega_a - \omega) \psi_{dr} + p \psi_{qr} \end{aligned} \quad (7)$$

$$\begin{aligned} \psi_{ds} &= (L_{ls} + L_m) i_{ds} + L_m i_{dr} \\ \psi_{qs} &= (L_{ls} + L_m) i_{qs} + L_m i_{qr} \\ \psi_{x1s} &= L_{ls} i_{x1s} \\ \psi_{y1s} &= L_{ls} i_{y1s} \\ \psi_{x2s} &= L_{ls} i_{x2s} \\ \psi_{y2s} &= L_{ls} i_{y2s} \\ &\dots \\ \psi_{o+s} &= L_{ls} i_{o+s} \\ \psi_{o-s} &= L_{ls} i_{o-s} \\ \psi_{dr} &= (L_{lr} + L_m) i_{dr} + L_m i_{ds} \\ \psi_{qr} &= (L_{lr} + L_m) i_{qr} + L_m i_{qs} \end{aligned} \quad (8)$$

where $L_m = (n/2)M$ and M is the maximum value of the stator to rotor mutual inductances in the phase-variable model. Symbols R and L stand for resistance and inductance, v , i and ψ denote voltage, current and flux linkage, while indices s , r identify stator/rotor variables/parameters. Index l identifies leakage inductances. Torque equation is given with

$$T_e = PL_m [i_{dr} i_{qs} - i_{ds} i_{qr}] \quad (9)$$

Model equations for d - q components in (7) and (8) and the torque equation (9) are identical as for a three-phase induction machine. This means that, in principle, the same control schemes will apply to multiphase induction machines as for three-phase machines. However, existence of x - y equations means that utilisation of a voltage source that creates stator voltage x - y components will lead to a flow of potentially large stator x - y current components, since these are restricted only by stator leakage impedance. In essence, x - y components correspond to certain voltage and current harmonics, the order of which depends on the machine's number of stator phases. Hence the inverter, used to supply a multiphase induction machine, must not create low-order voltage harmonics that will excite stator current low-order harmonic flow in x - y circuits. This issue is of particular importance when realising inverter PWM control and will be discussed in Section 4.

On the basis of (7) and (8) and assuming a single neutral point in stator winding it follows that after transformation of the model one has to deal with $(n-1)$ equations, since 0_+ component cannot be excited. However, if the stator winding of the machine is with $n = ak$, ($a = 3, 4, 5, 6, 7, \dots, k = 2, 3, 4, 5, \dots$) number of phases, then it is possible

to configure the complete winding as k windings with a phases each, with k isolated neutral points. This reduces the total number of equations after transformation to $n - k$, since in each star-connected winding zero-sequence cannot exist. For example, in a nine-phase machine with three three-phase windings shifted by 40° and with isolated neutrals there are only six equations instead of eight (when there is a single neutral). This feature is often exploited in multiphase motor drives since it has advantages with regard to fault tolerance, as discussed in Section 7. For practical purposes the most commonly used value is $a = 3$ with $k = 2$ or 3 . However, a may also take different values. For example, a 15-phase induction machine of [25–29] is configured for this purpose with three five-phase stator windings ($a = 5$, $k = 3$), supplied from three five-phase H-bridge voltage source inverters with separate DC links.

An alternative configuration of stator windings is often utilised when the total number of stator winding phases is $n = 3k$, $k = 2, 3, 4, 5, \dots$. Rather than placing the stator phases equidistantly along the circumference of the machine, one half of the angle $\alpha = 2\pi/n$ is used as the spatial shift between consecutive three-phase windings. This yields a six-phase machine with 30° displacement between two three-phase windings and a nine-phase machine with 20° displacement between three three-phase windings. Machines designed in this manner are called here asymmetrical induction machines, since the schematic representation of the magnetic axes of the individual stator phases is asymmetrical (see Section 6). Modelling of asymmetrical induction machines will again result in the same model equations (7)–(9), provided that an appropriate transformation matrix is applied. The decoupling transformation matrix for asymmetrical six-phase machine with two isolated neutral points is of the form [30, 31]

$$\underline{C} = \begin{matrix} \alpha \\ \beta \\ \sqrt{\frac{2}{6}} x_1 \\ y_1 \\ 0_+ \\ 0_- \end{matrix} \begin{bmatrix} 1 & \cos \frac{2\pi}{3} & \cos \frac{4\pi}{3} & \cos \frac{\pi}{6} & \cos \frac{5\pi}{6} & \cos \frac{9\pi}{6} \\ 0 & \sin \frac{2\pi}{3} & \sin \frac{4\pi}{3} & \sin \frac{\pi}{6} & \sin \frac{5\pi}{6} & \sin \frac{9\pi}{6} \\ 1 & \cos \frac{4\pi}{3} & \cos \frac{8\pi}{3} & \cos \frac{5\pi}{6} & \cos \frac{\pi}{6} & \cos \frac{9\pi}{6} \\ 0 & \sin \frac{4\pi}{3} & \sin \frac{8\pi}{3} & \sin \frac{5\pi}{6} & \sin \frac{\pi}{6} & \sin \frac{9\pi}{6} \\ 1 & 1 & 1 & 0 & 0 & 0 \\ 0 & 0 & 0 & 1 & 1 & 1 \end{bmatrix} \quad (10)$$

where the first three elements in each row are related to the first three-phase winding, while the remaining three elements apply to the second three-phase winding. It is assumed in (10) that neutral points of the two three-phase windings are not connected, as usually the case is. Application of (10) in conjunction with the subsequent rotational transformation again results in model equations (7)–(9), where there is a single pair of x – y component equations (x_1 – y_1) and zero-sequence equations do not exist.

Transformation matrix for asymmetrical multiphase machines with multiple three-phase windings is most easily formed using the vector space decomposition (VSD) approach, detailed in [31] (and addressed in more detail in Section 3.3). For example, application of the VSD approach to an asymmetrical nine-phase machine model, assuming a single neutral point, yields the transformation matrix given in [32]. It is possible to derive in the same manner transformation matrices for asymmetrical machines with higher number of phases (12, 15, etc.).

In the case of induction machines with $n = 3k$, $k = 2, 3, 4, 5, \dots$, an alternative approach to modelling [33, 34] is also utilised. Since the machine's stator winding consists of k three-phase star-connected windings with isolated neutral points, it is possible to formulate the transformation matrix in such a way that one obtains a pair of d – q equations for each three-phase winding, with the total torque determined as a sum of individual contributions of each of the three-phase windings. This modelling approach therefore results in a model where each of the three-phase windings gets described with a pair of equations identical to the d – q pair in (7) and (8). For example, an asymmetrical six-phase machine with two isolated neutral points is fully described with the model containing two pairs of d – q voltage and flux linkage stator winding equations. Application of this modelling approach is restricted to multiphase machines with multiple three-phase windings and it therefore lacks the generality offered by the model (7)–(9). Nevertheless, 'double d – q winding representation' of asymmetrical six-phase machines is often utilised for development of vector control schemes for this particular machine type [35–37], as discussed in Section 6.

As the number of phases of an induction machine increases it becomes progressively difficult to achieve sinusoidal distribution of the magneto-motive force, because of the limited number of slots along the stator circumference. On the other hand, sinusoidal distribution is actually often not even a desirable feature of a multiphase machine, since it prevents utilisation of one of the main advantages offered by such machines, torque enhancement by injection of higher stator current harmonics. If the stator winding is made as concentrated, then the magneto-motive force contains higher spatial harmonics. By injecting stator current time harmonics of the order that coincides with the spatial harmonic order it becomes possible to develop an average torque with these harmonic currents that is in addition to the torque produced by the fundamental stator current. This possibility is brought into existence by the fact that control of flux and torque associated with any particular current harmonic requires only two stator currents. The fundamental flux and torque components are therefore controlled using the stator d – q current components according to (7)–(9). Each of the additional pairs of x – y stator current components in (7) and (8) can be used to control an additional flux and torque component of the machine, caused by the injection of a certain stator current component. This possibility exists in all multiphase AC machines with an odd phase number, regardless of the type (e.g., synchronous reluctance machines [38, 39] and permanent magnet synchronous motor drives [40]). However, the possibility of utilising higher stator current harmonic injection for torque enhancement is severely restricted in machines with an even phase number. The only known case where this is a possibility is the asymmetrical six-phase motor drive, where application of the stator current third harmonic current injection requires operation of the machine with single neutral point, which has to be connected to either mid-point of the capacitor bank in the DC link or to a separate (seventh) inverter leg (induction motor drive [41–43] and permanent magnet synchronous motor drive [44]). In contrast to this, injection of the third stator current harmonic cannot be used for torque enhancement in a symmetrical six-phase drive.

From the modelling point of view, injection of stator current harmonics modifies both the transformation matrices and the resulting model. Since now stator-to-rotor coupling takes place not only between stator and rotor d – q components but also between the other pairs of stator and

rotor components, the pairs of axes after transformation are usually labelled $d1-q1$, $d3-q3$, $d5-q5$, and so on (rather than $d-q$, $x1-y1$, $x2-y2$, etc.) in accordance with the stator current harmonic order that appears as the torque enhancing in any particular pair of $d-q$ components. In a five-phase induction machine the third stator current harmonic is used to enhance the torque production and hence the model contains coupled stator and rotor $d1-q1$ and $d3-q3$ equations, with the total torque given as a sum of the contributions of the fundamental and the third stator current harmonic [45, 46]. In a seven-phase machine the third and the fifth stator current component can be used for torque enhancement [47], while a nine-phase symmetrical stator winding enables torque enhancement by simultaneous injection of the third, fifth, and seventh stator current harmonic [39]. More detailed considerations, related to the modelling and control of multiphase induction machines with higher stator current harmonic injection, are given in Section 5.2, in conjunction with five-phase induction motor drives.

3.3 Vector control of multiphase induction machines

As long as a multiphase induction machine is symmetrical, with sinusoidally distributed stator winding, and the transformation is based on the matrix in Fig. 1, the same vector control schemes as for a three-phase induction machine are directly applicable regardless of the number of phases. The only difference is that the co-ordinate transformation has to produce an n -phase set of stator current (or stator voltage) references, depending on whether current control is in the stationary or in the synchronous rotating reference frame. Indirect rotor flux oriented control (FOC) schemes for a multiphase induction machine, using these two types of current control, are illustrated in Figs. 2 and 3, respectively. In principle, the scheme of Fig. 2 utilises $(n-1)$ stationary current controllers (assuming stator winding with a single neutral point). Either phase currents or phase current components in the stationary reference frame can be controlled and here the standard ramp-comparison current control method offers the same quality of performance as with three-phase induction motor drives. On the other hand, the scheme of Fig. 3 has only two current controllers, which appears as an advantage at the first sight. However, since an n -phase machine essentially has $(n-1)$ independent currents (or $(n-k)$ in the case of the n -phase winding being formed of k identical

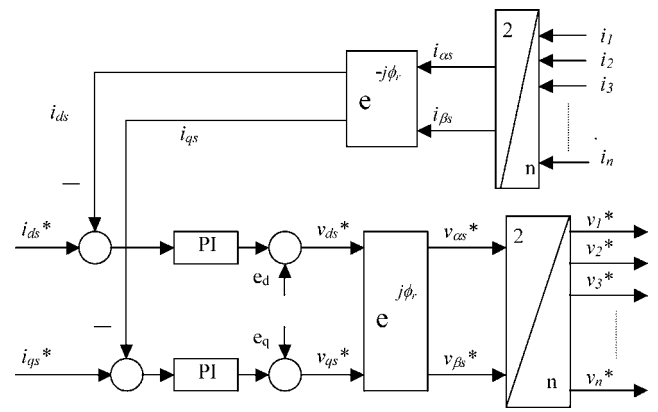

Fig. 3 Indirect rotor FOC of a multiphase induction machine – current control in the rotating reference frame (stator $d-q$ axis current references and rotor flux position obtained as in Fig. 2)

a -phase windings with isolated neutral points), utilisation of the scheme of Fig. 3 will suffice only if there are not any winding and/or supply asymmetries within the n -phase stator winding and/or supply. Furthermore, application of the vector control scheme of Fig. 3 also requires an adequate method of inverter PWM control to avoid creation of unwanted low-order stator voltage harmonics that represent voltage $x-y$ components in (7) and therefore lead to the flow of large stator current $x-y$ current components. The problem of winding/supply asymmetry is well documented for the asymmetrical six-phase induction machine (with two isolated neutral points) and it is in principle necessary to employ four current controllers when utilising the scheme of Fig. 3. This applies to both the control scheme based on the ‘double $d-q$ winding representation’ [35–37, 42, 48, 49] and to the control based on model (7)–(9) where, in addition to the $d-q$ stator current controllers of Fig. 3 one needs to add a pair of $x-y$ current controllers [50].

Although vast majority of control-related considerations in literature apply to either five-phase or asymmetrical six-phase induction machines, there are also reports related to other phase numbers. For example, indirect rotor FOC of a symmetrical 15-phase induction machine is considered in [51], while [25–29] dealt with a 15-phase induction machine for electric ship propulsion, configured as three five-phase stator windings (vector and DTC have been considered in [25, 28], while [27, 29] used V/f control). Control of a 15-phase induction motor drive was also discussed in [52]. An analysis of the possible supply options for a 36.5 MW, 16 Hz, nine-phase variable speed drive, aimed at electric ship propulsion has been reported in [6].

Provided that good quality of current control is achieved and/or an appropriate method of PWM for multiphase VSI is applied, the performance of a vector controlled multiphase induction machine will be very much the same as for its three-phase counterpart. As an example, Fig. 4 illustrates an experimental recording of a deceleration transient of the five-phase induction machine with rotor FOC according to Fig. 2, using ramp-comparison phase current control at 10 kHz inverter switching frequency [53]. Behaviour of the motor’s speed and torque is practically identical with what one would observe in a three-phase induction motor drive with corresponding settings of speed and current control loops.

Asymmetrical six-phase machine is undoubtedly the most frequently considered multiphase induction motor drive for high power applications. The choice of asymmetrical (30° displacement between two three-phase windings)

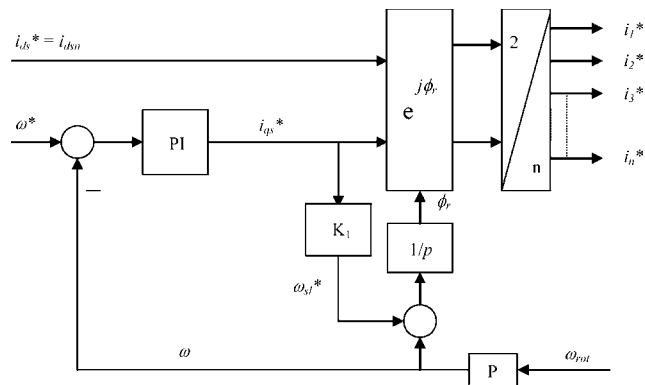

Fig. 2 Indirect rotor flux oriented controller for an n -phase induction motor with sinusoidal distribution of the magneto-motive force and phase current control ($K_1 = 1/(T_r^* i_{ds}^*)$; $p =$ Laplace operator; $T_r =$ rotor time constant; $\phi_r =$ instantaneous rotor flux space vector position; $\omega_{rot} =$ rotor mechanical angular speed)

rather than symmetrical (60° displacement between two three-phase windings) six-phase configuration was in the early days of the multiphase induction motor drives (pre-PWM era) dictated by the need to eliminate the sixth harmonic of the torque ripple, caused by the fifth and seventh harmonics of the stator current [33]. Utilisation of a proper PWM strategy, with sufficiently high switching frequency, for a six-phase VSI however leads to the performance of the asymmetrical and symmetrical six-phase machines that is practically the same [30, 54, 55]. Performance of a symmetrical six-phase induction machine with rotor FOC according to Fig. 2 (using again ramp-comparison current control at 10 kHz switching frequency) is illustrated in Fig. 5 [56]. Acceleration from standstill to 300 rpm is shown, together with the stator phase current in subsequent steady state operation at 300 rpm. The transient behaviour is commensurate with the one obtainable with a vector controlled three-phase induction motor drive, while steady-state stator current spectrum shows absence of any unwanted low-order harmonics.

3.4 Direct torque control

Two basic approaches to DTC of three-phase induction machines can be identified. In the first approach, hysteresis stator flux and torque controllers are utilised in conjunction with an optimum stator voltage vector selection table, leading to a variable switching frequency. In the second approach, switching frequency is kept constant by applying an appropriate method of inverter PWM control (usually space vector PWM). In principle, both approaches are also applicable to multiphase induction machines and the achievable dynamic performance is very much the same as for three-phase induction machines. However, there are some important differences, predominantly caused by the existence of additional degrees of freedom in multiphase machines ($x-y$ components).

Assuming that the multiphase machine is with sinusoidal magneto-motive force distribution, DTC scheme needs to apply sinusoidal voltages to the machine's stator winding (neglecting PWM ripple), without any unwanted low-order frequency components that would excite $x-y$ circuits. If the constant switching frequency DTC is utilised, this problem can be solved relatively easily. It is only necessary to apply one of the PWM methods, discussed in Section 4, which will provide inverter operation with sinusoidal (or at least near-sinusoidal) output voltages. For example, in the case

of an asymmetrical six-phase machine supplied from two three-phase inverters one may apply standard carrier-based PWM with third harmonic injection for the control of each of the two three-phase inverters [57]. This will yield operation with near-sinusoidal inverter output, with negligible content of the fifth and the seventh stator voltage harmonics (which lead to the flow of $x-y$ stator current components that are restricted only by stator winding leakage impedance, (7) and (8)). Hence constant switching frequency DTC of a multiphase induction machine can be realised without problem, by using an appropriate PWM method that ensures sinusoidal voltage output from the inverter.

It is also possible to devise DTC schemes with higher stator current injection for multiphase machines with concentrated windings. An example of such a DTC scheme is the one of [58], where a five-phase permanent magnet synchronous machine was analysed. It is a constant switching frequency DTC, where the overall stator voltage reference is built on the basis of voltage requirements for the fundamental and the third harmonic.

A problem that is encountered in hysteresis based DTC schemes for sinusoidal multiphase machines is that optimum stator voltage vector selection table, designed in the same manner as for a three-phase induction machine, dictates application of a single space vector in one (variable) switching period [46, 59, 60]. However, each individual inverter output voltage space vector leads to generation of unwanted low-order harmonics, which excite $x-y$ stator circuits and lead to large stator current low-order harmonics. It appears that this problem has not been solved so far for any phase number higher than three, the exception being asymmetrical six-phase induction machine [61]. DTC scheme of [61] similar to [57] is based on utilisation of two three-phase inverters for the two three-phase windings with isolated neutral points, shifted by 30° . It is clearly shown in both [57] and [61] that utilisation of standard hysteresis stator flux and torque controllers in conjunction with an optimum switching table (ST) (where only 12 large vectors are utilised) leads to operation with substantial low-order stator current harmonics (the fifth and seventh). The problem is circumvented in [57] by using constant switching frequency DTC with double zero-sequence injection, while the solutions discussed in [61] are all based on modifications of the basic hysteresis based DTC. In principle, an additional hysteresis controller is introduced and the complexity of the control scheme is substantially increased. The modifications suggested in [61] for the hysteresis based DTC of an asymmetrical six-phase machine

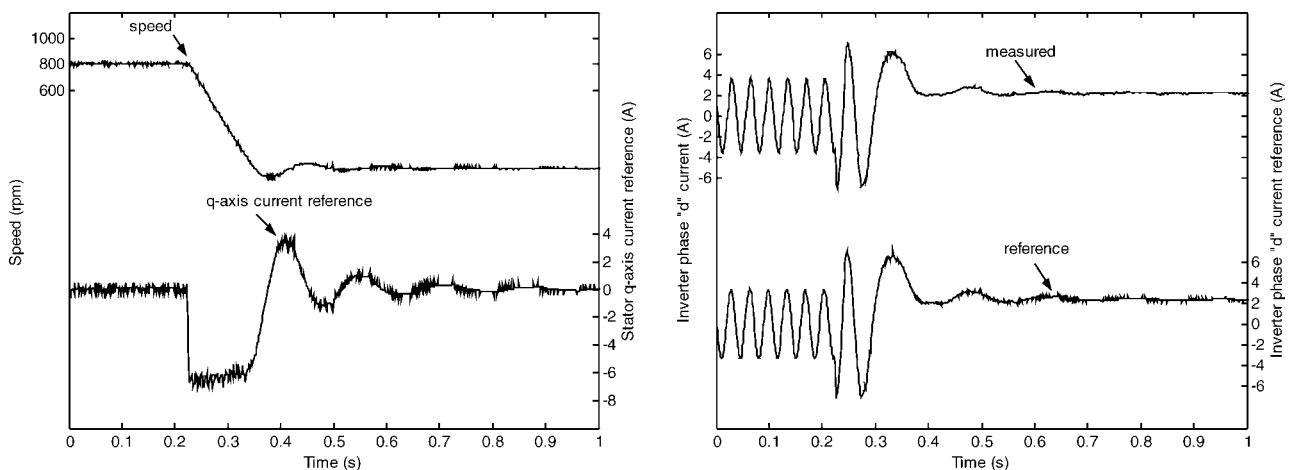

Fig. 4 Speed response, stator q -axis current reference (peak), and comparison of inverter measured and reference phase current during deceleration of a five-phase induction motor from 800 to 0 rpm under no-load conditions, using control scheme of Fig. 2

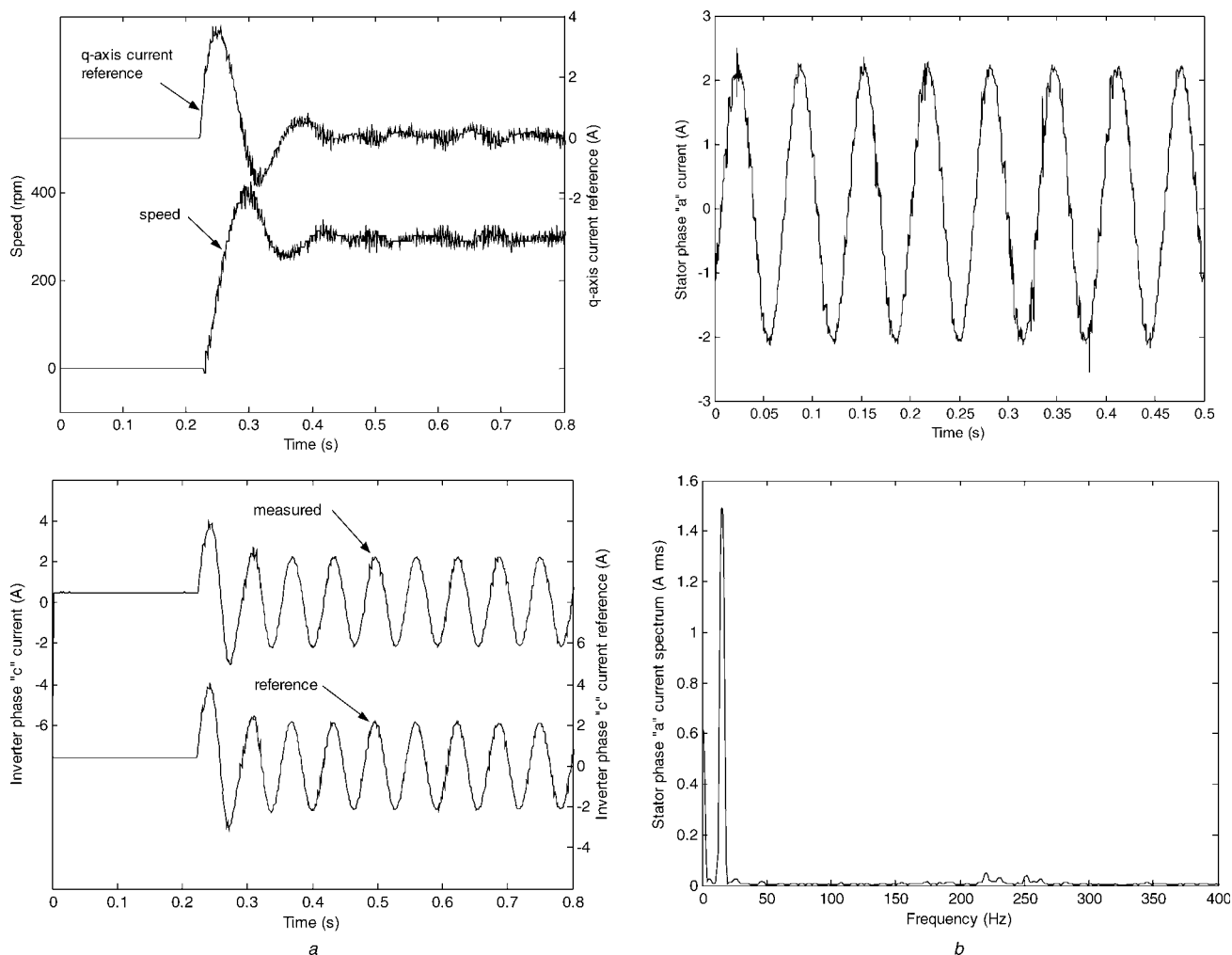

Fig. 5 Indirect rotor FOC of a symmetrical six-phase induction motor drive using controller of Fig. 2 and ramp comparison current control

a Acceleration from standstill to 300 rpm

b Stator current (time-domain waveform and spectrum) in steady state operation at 300 rpm (15 Hz)

appear as potentially extendable to other induction machines with multiple three-phase stator windings.

Application of hysteresis based DTC in conjunction with concentrated winding machines can however be effectively done using optimum stator voltage vector selection table with large vectors only, since in this case at least some of the low-order harmonics actually lead to torque enhancement by higher stator current harmonic injection. For example, in a five-phase machine utilisation of large vectors only generates the third harmonic. Hence the third stator current harmonic flows. However, since the winding is concentrated, the third current harmonic couples with the third harmonic of the magneto-motive force and produces an average torque. This yields an enhancement of the average torque. This scheme is considered in more detail in Section 5.3.

4 PWM control of multiphase voltage source inverters

4.1 Introduction

Multiphase induction motor drives are currently invariably supplied from two-level multiphase voltage source inverters. As the number of phases of the inverter increases, the available number of inverter output voltage space vectors changes according to the law 2^n . Hence a five-phase

VSI offers 32 voltage space vectors, while a nine-phase VSI (supplying a symmetrical nine-phase machine with single neutral point) has 512 output voltage space vectors. This means that, as the number of phases increases, the problem of devising an adequate space vector PWM scheme becomes more and more involved. On the other hand, carrier-based PWM for three-phase VSIs is easily extendable to multiphase VSIs. In what follows a review of available approaches to PWM control of multiphase VSIs is provided.

4.2 Carrier-based PWM schemes

As already discussed in Section 3.4, the problem that arises in PWM control of multiphase VSIs is how to avoid generation of unwanted low-order harmonics that lead to the flow of stator harmonic currents in $x-y$ circuits. The most straightforward approach is undoubtedly utilisation of the carrier-based PWM methods [62]. Similar to the carrier-based PWM with third harmonic injection for a three-phase VSI it is possible to improve the DC bus utilisation in multiphase VSIs by injecting the appropriate zero-sequence harmonic (or adding the offset) into leg voltage references [63, 64]. As the number of phases increases the improvement in the DC bus utilisation by zero-sequence harmonic injection reduces [65]. The gain in maximum fundamental in the

linear modulation region is only 5.15% for the five-phase VSI, while it is 15.47% in the three-phase VSI.

The principle of carrier-based PWM with zero-sequence harmonic injection has frequently been utilised for asymmetrical multiphase machines with a certain number of three-phase windings, supplied from three-phase VSIs. In the case of asymmetrical six-phase induction machine this leads to double zero-sequence injection (i.e. injection of the third harmonic in each of the two three-phase VSIs) as detailed in [31, 66, 67]. According to this approach, the six-phase inverter consists of two independent three-phase inverters sharing the same DC link. The asymmetrical six-phase machine must have isolated neutral points. In this case, from the machine's point of view, the voltage space vectors provided by two three-phase inverters in α - β plane form two hexagons, phase shifted by 30 electrical degrees. Two three-phase inverters are controlled by two three-phase identical modulators employing the injection of two three-phase zero-sequence waveforms (Fig. 6, where S_γ ($\gamma = a1, b1, c1, a2, b2, c2$) are phase switching functions of the six-phase inverter and v_s^* denotes reference space vector of the first ($a1, b1, c1$) three-phase winding; this space vector reference is generated by means of current controllers, as discussed later in Section 6). The phase rotation of ± 30 electrical degrees shown in Fig. 6 depends on the phase displacement between the two machine's three-phase stator sets $a1, b1, c1$ and $a2, b2, c2$, respectively.

It should be noted that this approach for asymmetrical six-phase induction machine is not optimal [31, 67], since lower fifth and seventh harmonics can be obtained using VSD technique of [31] (discussed shortly). However, the easiness of implementation with industrial processors is its main advantage; also the linear modulation region is extended by the same amount (15.47%) as for the three-phase VSI employing third harmonic injection. As an illustration, Fig. 7a shows experimentally recorded machine's phase voltage v_{a1} , the inverter phase duty-cycle δ_{a1} , and the machine's phase current i_{a1} for operation at 150 Hz fundamental frequency. The motor prototype (10 kW, 40 V rated phase voltage) is operated at no-load. The spectrum of phase voltage is depicted in Fig. 7b, showing sufficiently low fifth and seventh harmonic voltages.

The main advantage of the carrier-based PWM techniques, the easiness of implementation, becomes more and more pronounced as the phase number increases. For example, in the 15-phase VSI there are 2^{15} space vectors and devising any space vector based PWM for online

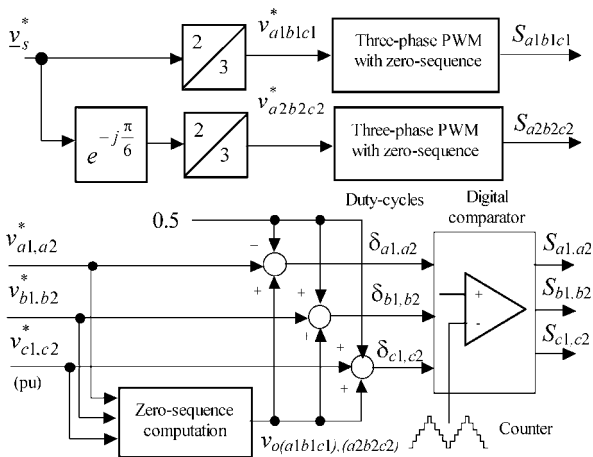

Fig. 6 Double zero-sequence injection PWM for asymmetrical six-phase drives

implementation would be a formidable task. On the other hand, carrier-based PWM implementation is rather straightforward [51]. Carrier-based PWM has also been considered in conjunction with symmetrical nine-phase machine (with three isolated neutral points) and an optimum pulse pattern PWM has been developed, which yields a better performance than the carrier-based PWM [68].

One very specific application of the carrier-based PWM is related to the multiphase series-connected induction motor drives, discussed in Section 8. In this case, the multiphase VSI output voltage is required to contain two (or more, as appropriate) fundamental voltage components of different phase sequence and in general different magnitudes and frequencies. If carrier-based PWM is used, the modulation scheme is straightforward and very simple to implement, as discussed in [69] for a five-phase two-motor drive. It is still possible to utilise DC offset addition to improve the DC bus utilisation and the inverter leg voltage references are simply formed by summing the two appropriate sinusoidal signals (of in general different magnitudes and different frequencies) [69]. The experimentally recorded (filtered) output line-to-line voltage of the five-phase inverter supplying two series-connected five-phase induction machines is illustrated in Fig. 8, where both instantaneous waveform and the spectrum are shown.

4.3 Space vector PWM for multiphase VSIs

To facilitate the discussion of the space vector PWM techniques for multiphase VSIs a five-phase VSI is taken as an example. Since the neutral point is isolated, one has two pairs of equations describing the five-phase induction machine in (7) and (8), d - q and x - y (considering the stationary reference frame, d - q becomes α - β). These two pairs of components correspond to two two-dimensional sub-spaces of the five-dimensional space (since neutral is isolated the fifth dimension, zero-sequence, can be omitted from consideration). Two planes formed by α - β and x - y are mutually perpendicular, so that there is no coupling between the two. This constitutes the basis of the VSD approach [31]. Using the transformation matrix in Fig. 1 one defines two space vectors, one per plane that can be used to describe the inverter output voltages in the stationary reference frame [70]

$$\begin{aligned} v_{\alpha\beta} &= v_\alpha + jv_\beta = 2/5(v_a + \underline{a}v_b + \underline{a}^2v_c + \underline{a}^*v_d + \underline{a}^*v_e) \\ v_{xy} &= v_x + jv_y = 2/5(v_a + \underline{a}^2v_b + \underline{a}^*v_c + \underline{a}v_d + \underline{a}^*v_e) \end{aligned} \quad (11)$$

Power variant transformation is used in (11) (in contrast to Fig. 1), symbol * stands for complex conjugate, $\underline{a} = \exp(j2\pi/5)$ and v_a, v_b, v_c, v_d, v_e are the inverter output phase voltages. By applying (11) in conjunction with inverter phase voltages for each of the 32 inverter states, one obtains the space vectors in the α - β and x - y sub-spaces. There are 30 active space vectors and two zero space vectors. Each active space vector maps simultaneously into both α - β and x - y sub-space. Large vectors of the α - β plane map into small vectors of the x - y plane, medium length vectors map into medium length vectors, while small vectors of the α - β plane map into large vectors of the x - y plane. Harmonics in the α - β plane are of the order $10k \pm 1$ ($k = 0, 1, 2, \dots$) while harmonics in the x - y plane are of the order $5k \pm 2$ ($k = 1, 3, 5, \dots$). Hence, if only ten large vectors are used (by analogy with a three-phase VSI), the x - y plane will inevitably be excited, leading to the flow of large low-order stator

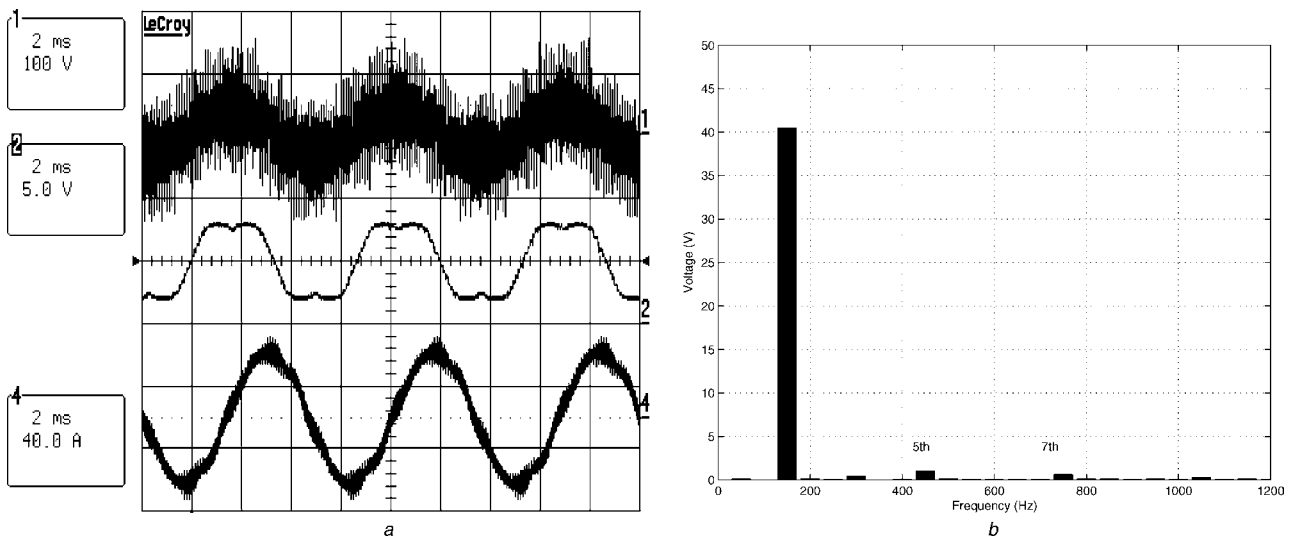

Fig. 7 Experimental results using double zero-sequence injection PWM for asymmetrical six-phase induction machine
a Time domain waveforms of v_{a1} (Trace 1, 100 V/div), duty-cycle of phase $a1$ (Trace 2, 1 p.u. = 5 V) and stator phase current i_{a1} (Trace 3, 40 A/div)
b Spectrum of output phase voltage v_{a1}

current harmonics (predominantly the third and the seventh). This is the problem that appears in implementation of hysteresis-based DTC, addressed in Section 3.4. It is also the problem that has been evidenced in the early days of space vector PWM implementation for vector controlled five-phase AC motor drives [59, 71]. The experimentally recorded output phase voltage of a five-phase VSI, together with its spectrum, is illustrated in Fig. 9 for the case when only large vectors are used and the reference voltage is of the maximum value achievable in the linear modulation region. As can be seen, the third harmonic is around 30%, while the seventh harmonic is around 5% of the fundamental. These percentage values apply to all reference voltage settings when only large vectors are used [72]. Early attempts to develop space vector PWM schemes for asymmetrical six-phase VSI were characterised with very much the same approach (selection of large vectors, forming the outermost 12-sided polygon, only). The result was also very much the same, since large fifth and seventh harmonic stator current harmonics were observed

due to the generation of the output voltage in the $x-y$ plane [73, 74].

Problems experienced with space vector PWM based on utilisation of the largest (outermost) vectors only can be easily alleviated if the basic rule [63, 75] is observed. To avoid existence of unwanted low-order harmonics in the output voltages one has to apply $n - 1$ active space vectors ($n = \text{odd}$) during one switching period. It then becomes possible to zero the average applied space vector in the $x-y$ plane(s) and to obtain multiphase inverter operation with purely sinusoidal output voltages (neglecting the switching ripple). In the considered five-phase VSI one selects the two medium and the two large vectors in the $\alpha-\beta$ plane, which neighbour the reference. Similarly, in a seven-phase VSI one would select six active vectors, while symmetrical nine-phase VSI with single neutral point requires selection of eight active space vectors. Once when the VSI active space vectors are selected, it is necessary to calculate their dwell times. Two approaches to this calculation can be identified. The first one is based

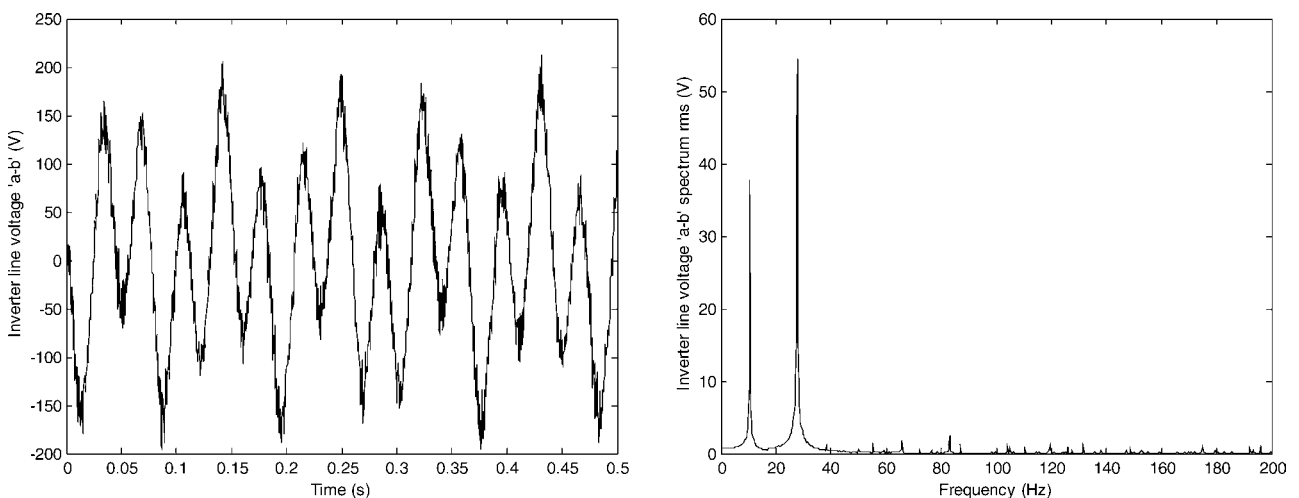

Fig. 8 Five-phase VSI line-to-line voltage and its spectrum for series-connected two-motor drive: carrier-based PWM with modulating signals composed of two sinusoidal components of different frequency and amplitude

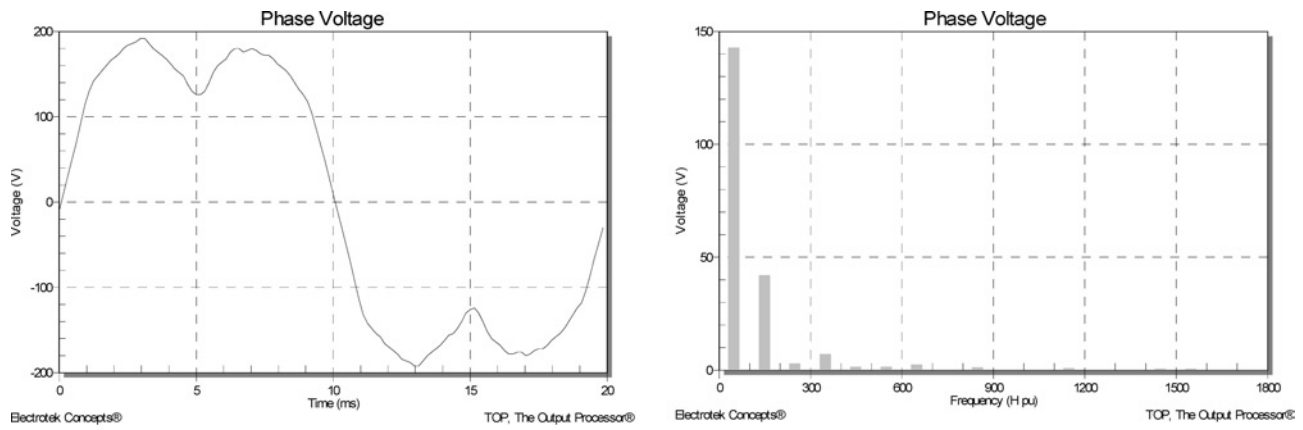

Fig. 9 Output phase voltage of a five-phase VSI obtained using space vector PWM with large vectors only (maximum output fundamental in the linear modulation region at 50 Hz, instantaneous waveform and spectrum are shown)

on the VSD approach [31] and it can be described with the following general set of equations (five-phase VSI is again discussed for simplicity)

$$\begin{aligned}
 \sum_{k=1}^n v_{k\alpha} \cdot t_k &= v_{\alpha}^* T_s & \sum_{k=1}^n v_{k\beta} \cdot t_k &= v_{\beta}^* T_s \\
 \sum_{k=1}^n v_{kx} \cdot t_k &= v_x^* T_s & \sum_{k=1}^n v_{ky} \cdot t_k &= v_y^* T_s \\
 \sum_{k=1}^n t_k &= T_s
 \end{aligned} \quad (12)$$

Here k denotes the selected VSI space vectors ($k = 1$ to 5 , since $n = 5$, where there are four active and one zero vector), t_k stands for selected vector dwell times, T_s is the inverter switching period, v_{α}^* , v_{β}^* are the reference space vector projections along $\alpha - \beta$ axes, v_x^* , v_y^* are the reference space vector projections along $x - y$ axes, and indices $k\alpha$, $k\beta$, kx , ky stand for projections of the selected space vectors along the four axes of the four-dimensional space. When sinusoidal output is required, one sets $v_x^* = 0$, $v_y^* = 0$ in (12) so that the right-hand side of the two equations in the second row equals zero. Calculation of dwell times using (12) is very time consuming for online implementation, even when sinusoidal output is required. Some improvement in this respect has been reported in [76]. If the required output is sinusoidal, an alternative approach (discussed shortly) is preferred. However, if harmonic injection is applied for the sake of torque enhancement (so that $v_x^* \neq 0$, $v_y^* \neq 0$), this approach is the only one currently available in conjunction with space vector PWM. Successful implementation of this approach to space vector PWM with third harmonic injection for a five-phase VSI has been demonstrated in [77].

It is important to emphasise here that application of (12) is currently restricted to inverter operation with either sinusoidal output or the operation with harmonic injection for torque enhancement, since it requires that the active space vectors are known (i.e. they have already been selected). In a more general case when there are two completely independent fundamental voltage references, one in $\alpha - \beta$ plane and the other in the $x - y$ plane, as required in series-connected two-motor five-phase drives of Section 8, there is no interdependence between the two references (as the case is with higher harmonic injection) and the reference voltage in $x - y$ plane may be both smaller and larger than the reference in the $\alpha - \beta$ plane (this will depend on the

operating frequencies of the two machines) and in principle located anywhere in the plane. The problem that arises in this case is how to select the four active vectors that are to be used to synthesise the two voltage references, since selection of active vectors on the basis of the reference in one plane automatically restricts the realisable reference in the other plane. Theoretical considerations related to this issue are available in [78]. A convenient space vector PWM method for series-connected two-motor drives of Section 8 is yet to be proposed (while application of carrier-based PWM is straightforward, as discussed in Section 4.2).

Utilisation of both medium and large voltage vectors for sinusoidal output voltage generation cannot provide maximum DC bus utilisation in either five-phase [72, 77] or asymmetrical [31, 79] and symmetrical six-phase VSIs [80]. This is so since full DC bus utilisation always requires application of the largest VSI space vectors only (which in turn results in the harmonics in the $x - y$ plane, Fig. 9).

Carrier-based PWM of Section 4.2 and the corresponding space vector PWM will result in the application of the same space vectors for a five-phase VSI. The PWM pattern will be symmetrical and switching frequency of all legs will be the same (and equal to the inverter switching frequency). However, the situation is different for an asymmetrical six-phase VSI. By selecting for application two plus two large vectors neighbouring the reference in the $\alpha - \beta$ plane from each side [31] one achieves lower voltage harmonics in the $x - y$ plane than with double zero-sequence injection method [31, 67]. An alternative method of space vector selection for asymmetrical six-phase VSIs, based on utilisation of an ANN, is described in [81]. It should however be noted that, in contrast to the symmetrical six-phase VSI and the VSIs for odd phase numbers, it appears that generation of perfectly sinusoidal output voltages (with zero $x - y$ components) does not seem to be possible for an asymmetrical six-phase VSI [55, 76].

As already noted, space vector PWM based on utilisation of (12) for online implementation is time-consuming. An alternative approach, based on explicit analytical expressions for dwell time calculation, similar to what is used for three-phase VSIs, is therefore preferred. Analytical expressions for dwell times of a five-phase VSI, for sinusoidal output voltage operation, have been developed in [72, 82, 83]. Similar considerations for a nine-phase VSI are given in [75]. Symmetrical six-phase VSI space vector PWM is covered in detail in [80], where again explicit expressions for dwell times of applied space vectors are given. As an example, Fig. 10 illustrates experimental recording of output phase voltage of a symmetrical

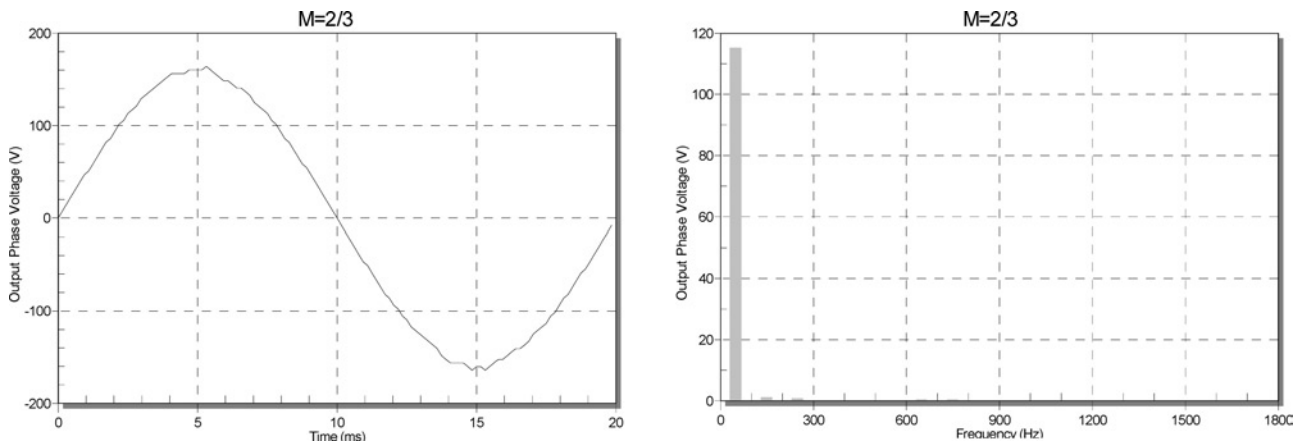

Fig. 10 Time-domain waveform and spectrum of the symmetrical six-phase inverter output phase voltage with dwell time adjustment for sinusoidal output

six-phase VSI with single neutral point and dwell time adjustment to yield sinusoidal output. An alternative method for computation of duty cycles for the space vectors used to synthesise the reference is given in [84, 85].

One particular feature of the space vector PWM for inverters with an even number of phases is that it is possible to achieve operation with zero instantaneous common mode voltage (CMV). Since such operation requires that the inverter leg voltages sum to zero instantaneously, only space vectors that satisfy this condition are utilised. This restricts severely the number of space vectors that can be used. In the asymmetrical six-phase VSI this means that only 18 active and two zero space vectors can be utilised and the maximum achievable fundamental is lower than when all active states are utilised [86]. Very much the same considerations apply to a symmetrical six-phase VSI as well [87]. In essence, schemes for zero instantaneous CMV for six-phase VSIs can be viewed as an extension of the method proposed for dual-voltage three-phase induction motors in [88], where two three-phase inverters were used to achieve zero CMV.

The space vector PWM schemes surveyed so far lead to symmetrical PWM with commutation in a single inverter leg in transition from one space vector to the other, so that the minimum number of switchings takes place and the switching frequency of all inverter legs is the same (and equal to the inverter switching frequency). It is also possible to devise space vector PWM schemes where switching frequency varies from one inverter leg to the other. An example of such a scheme is the space vector PWM for a symmetrical six-phase VSI, given in [89]. Although it yields sinusoidal output, uneven switching frequency in different inverter legs makes it inferior when compared to other schemes for sinusoidal output voltage generation, given in [80]. However, space vector PWM with variable inverter leg switching frequency may be justifiable in the context of the torque ripple minimisation [62]. This requires selection of the space vectors that are the nearest to the reference. Such space vector PWM methods have been discussed in detail in [62] for a five-phase VSI and to some extent in [80] for a symmetrical six-phase VSI. To minimise the torque ripple while simultaneously ensuring either full cancellation or near-cancellation of the current harmonics in the $x-y$ plane, it is suggested in [62] to apply three different PWM methods for a five-phase VSI, depending on the modulation index value. If modulation index is low, application of two small and two medium-length active vectors that neighbour

the reference ensures full cancellation of $x-y$ current harmonics with a minimised torque ripple. For intermediate values of the modulation index either the method of [62] or those of [72, 82, 83] can be used with the same effect. For high modulation index values it is suggested in [62] to apply ‘triangle modulation’ by selecting three active vectors (two large and one medium). Although in this region it is then not possible to cancel fully low-order harmonics, torque ripple is minimised and additionally, full DC bus voltage utilisation is enabled.

Space vector PWM for multiphase inverters is in essence an n -dimensional problem. VSD is a relatively simple way of dealing with it in two-dimensional subspaces. The attempts to formulate the space vector PWM directly, using n -dimensional space, are rare. Such an approach was investigated for a five-phase VSI supplying two series-connected five-phase induction machines in [90] and was deemed to be of little practical value because of the huge complexity involved in the selection of the space vectors. Some improvement with regard to the dwell time calculation has been reported in [91]; however the problem of the space vector selection remains the main obstacle in the application of the n -dimensional space vector PWM.

4.4 Multiphase multilevel voltage source inverters

By and large, existing considerations of multiphase induction motor drives are related to two-level VSI supply. An attempt to develop a multilevel multiphase induction motor drive for a locomotive application is described in [92]. An asymmetrical nine-phase induction machine is used, configured into three three-phase windings with isolated neutral points. These are supplied from three-phase three-level inverters. Since the neutrals are isolated, three-level inverter control is an extension of what is used in three-phase drives. The same applies to the considerations related to asymmetrical six-phase induction motor drive in [93], where two five-level three-phase inverters are used. Multilevel VSIs are also considered in [6] as one of the options for the supply of a 36.5 MW electric ship propulsion drive. Some theoretical considerations are given in conjunction with four- and five-level nine-phase VSIs as potential solutions, while more detailed simulation study has been reported for the three-level nine-phase VSI [6]. As far as the VSIs with other phase numbers are concerned, there is little evidence of any existing developments. Some preliminary considerations related to multilevel inverter applications for five-phase induction motor drives are available

in [62]. Theoretical and simulation considerations, related to multilevel operation of three five-phase H-bridge inverters aimed at supplying the 15-phase induction motor for ship propulsion [29], show that the increase in the number of levels can considerably improve the current and torque ripples, when compared to the simplest two-level mode of operation.

5 Five-phase induction motor drives

5.1 Introduction

Vector control of a five-phase induction motor drive, using only fundamental stator current in conjunction with sinusoidally distributed stator winding, has been discussed in Section 3.3. Various PWM schemes, applicable to a five-phase voltage source inverter have also been elaborated in Section 4. The purpose of this section is therefore to provide a more detailed treatment of vector control schemes that utilise higher harmonic injection, and of DTC, in conjunction with a five-phase induction machine with concentrated stator winding.

5.2 Vector control of five-phase induction motor drives with third stator current harmonic injection

The principle of higher stator current harmonic injection is equally applicable to all types of multiphase machines, including both induction [45, 46] and synchronous machines [38, 39, 94, 95]. Torque enhancement in this manner is possible only if the stator winding magneto-motive force distribution contains corresponding spatial harmonics, so that the machine is in this case designed with concentrated rather than distributed stator winding [96]. If the induction motor is wound with the concentrated windings (Fig. 10), the air-gap flux can be made to take on a quasi-rectangular rather than sinusoidal shape by using the harmonics. Besides providing a possibility of torque enhancement by the third harmonic injection, this strategy also offers other advantages. With a sinusoidal flux distribution, as found in a conventionally excited induction motor, only one tooth per pole can be fully saturated at any instant of time, corresponding to the peak of the air-gap flux wave. The other teeth are un-saturated, and the iron in those teeth could be regarded as being under-utilised (at that instant). In contrast, if the air-gap flux distribution has a nearly rectangular waveform, all teeth carry the same flux, and so stator tooth iron is utilised to a greater extent. However, if the same peak air-gap flux density is used with both a sinusoidal and a square-wave

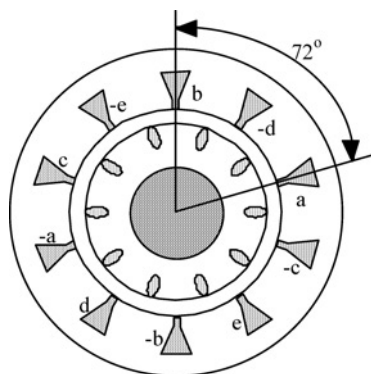

Fig. 11 Five-phase concentrated-winding induction machine

distribution, the maximum flux density in the core is increased by a factor of $\pi/2$. A machine designed for a square-wave air-gap flux will therefore have either a deeper core back, or a lower peak air-gap flux density, then a machine with a sinusoidally distributed air-gap field.

Motor torque enhancement by higher stator current injection requires that the magnetic field established by the interaction of the injected current harmonic and the corresponding spatial magneto-motive force harmonic rotates at the synchronous speed of the fundamental harmonic [45, 46]. This translates into the requirement that the machine is wound in such a way that the harmonic currents set up a number of poles equal to the product of the harmonic order and the pole number of the fundamental. In an n -phase machine ($n = \text{odd}$) this is possible for every odd harmonic up to the number of phases, meaning that for a five-phase machine the third harmonic can be used for this purpose. All harmonics of the order higher than the machine's phase number continue to create only losses and some create torque pulsation.

Since now the phase domain model of the machine contains appropriate higher harmonics of the inductance coefficients, the transformation from the phase domain into a common rotating reference frame has to be changed to obtain a model with constant coefficients. In the case of five-phase machine, the inductance coefficients contain the fundamental and the third harmonic. These two harmonics appear in two mutually orthogonal sub-spaces ($d-q$ and $x-y$ in the sense of notation used in Section 3.2). Assuming isolated neutral point, the transformation into an arbitrary rotating reference frame is performed using ($\theta_s = \int \omega_a dt$)

$$\underline{T} = \sqrt{\frac{2}{5}} \begin{bmatrix} d_1 \begin{bmatrix} \cos(\theta_s) & \cos(\theta_s - \alpha) & \cos(\theta_s - 2\alpha) \\ -\sin(\theta_s) & -\sin(\theta_s - \alpha) & -\sin(\theta_s - 2\alpha) \end{bmatrix} \\ \sqrt{\frac{2}{5}} d_3 \begin{bmatrix} \cos 3(\theta_s) & \cos 3(\theta_s - \alpha) & \cos 3(\theta_s - 2\alpha) \\ -\sin 3(\theta_s) & -\sin 3(\theta_s - \alpha) & -\sin 3(\theta_s - 2\alpha) \end{bmatrix} \\ q_3 \begin{bmatrix} \cos(\theta_s - 3\alpha) & \cos(\theta_s - 4\alpha) \\ -\sin(\theta_s - 3\alpha) & -\sin(\theta_s - 4\alpha) \\ \cos 3(\theta_s - 3\alpha) & \cos 3(\theta_s - 4\alpha) \\ -\sin 3(\theta_s - 3\alpha) & -\sin 3(\theta_s - 4\alpha) \end{bmatrix} \end{bmatrix} \quad (13)$$

With respect to the model of a sinusoidally wound machine (7)–(9), nothing changes in the $d-q$ equations in (7) and (8), except that all variables and the magnetising inductance obtain an additional index, 1. The form of $x-y$ equations of (7) and (8) however attains a completely different form, which is in principle the same as for d_1-q_1 equations, except for a scaling factor 3 in rotational electromotive force terms. The variables become d_3-q_3 and the magnetising inductance has an additional index 3. Consequently, the torque equation (9) becomes (in terms of rotor flux and stator current components)

$$T_e = T_{e1} + T_{e3} = P(L_{m1}/L_{r1})(\psi_{dr1}i_{qs1} - \psi_{qr1}i_{ds1}) + 3P(L_{m3}/L_{r3})(\psi_{dr3}i_{qs3} - \psi_{qr3}i_{ds3}) \quad (14)$$

where indices 1 and 3 identify the fundamental and the third harmonic variables/inductances, respectively.

Rotor FOC can again be realised using current control in either stationary or rotating reference frame. As an example, Fig. 12 [45, 46] illustrates the control scheme based on the principle of indirect rotor flux orientation assuming current control of stator phase currents, which now replaces Fig. 2

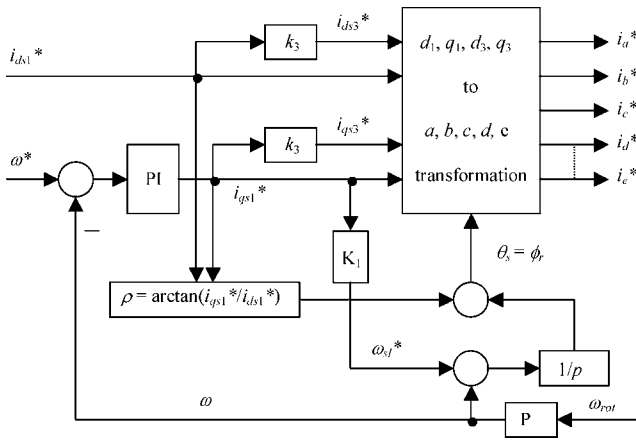

Fig. 12 Indirect rotor field oriented control of a five-phase induction machine with the third stator current harmonic injection, using phase current control

valid for a sinusoidal five-phase machine. The coefficient k_3 in Fig. 12 is associated with the relative value of the third harmonic stator current $d_3 - q_3$ references with respect to $d_1 - q_1$ current references and its value is set for the following experimentally obtained results to 15% [46]. Angle ρ is the dynamic compensating angle. Through its dynamic adjustment, for the fundamental currents and the third harmonic of the fundamental current waveform, the desired field oriented control and the nearly rectangular current waveform and flux distribution can be achieved.

It is possible to devise in a similar manner vector control schemes that operate with current control in the synchronous reference frame and therefore replace the scheme of Fig. 3 when higher stator current harmonics are injected. Such control schemes are elaborated in [40, 97].

Transient and steady-state operation of a vector-controlled five-phase 7.5 hp induction machine, using control scheme of Fig. 12, are illustrated in Figs. 13 and 14, respectively [46]. The machine is loaded with a DC generator. Dynamic behaviour during acceleration transients (Fig. 13) is excellent, as can be concluded by observing the relationship between the reference and the actual speed. Measured stator current in steady state (Fig. 14) confirms

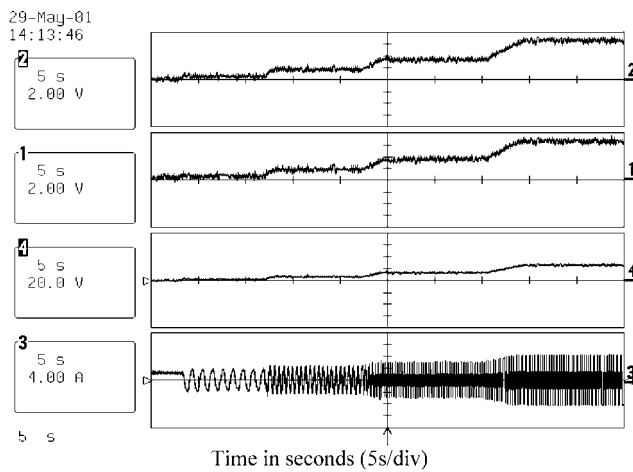

Fig. 13 Experimental results of vector control, using the fundamental and the third stator current harmonic, in transient operation

From top to bottom: reference speed (120 rpm/div), actual speed (120 rpm/div), output torque (50 in-lb/div), and stator current (4 A/div)

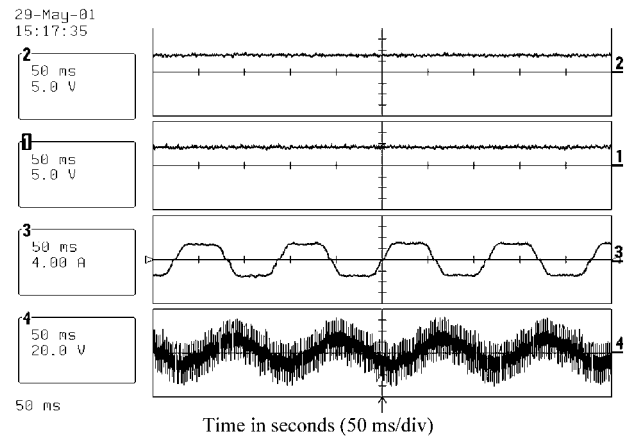

Fig. 14 Experimental results of vector control, using the fundamental and the third stator current harmonic, in steady-state operation

From top to bottom: d_1 -axis current (2 A/div), q_1 -axis current (4 A/div), stator current (4 A/div), and stator voltage (20 V/div)

the presence of the third harmonic, in addition to the fundamental.

5.3 DTC of five-phase induction motor drives

As already noted, it is possible to devise both constant switching frequency and variable switching frequency (hysteresis-based) DTC schemes for multiphase machines. An example of a constant switching frequency DTC scheme is given in Section 6 in conjunction with asymmetrical six-phase machine with sinusoidally distributed stator winding. Hysteresis-based DTC is therefore considered in this section. Further considerations are valid for both distributed and concentrated winding five-phase machines. However, achievable performance using the described DTC is significantly better if the machine is with concentrated windings, as explained later.

The basic hysteresis-based DTC scheme is illustrated in Fig. 15 and it is in essence identical to its three-phase counterpart [59, 60]. Torque hysteresis comparator can be three-level (so that zero voltage vectors are used for torque decrease) or two-level (so that only active voltage vectors are used: this case is illustrated in Fig. 15). The only difference is in the optimum voltage vector selection table, since there are 32 (rather than eight) stator voltage

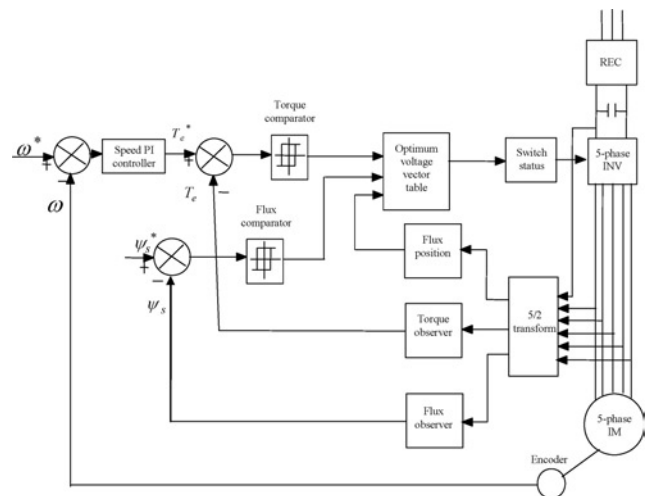

Fig. 15 Block diagram of hysteresis-based DTC for a five-phase induction motor drive

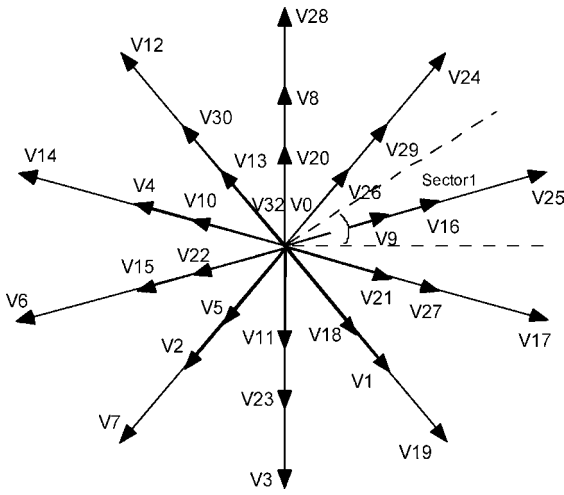

Fig. 16 Voltage space vectors of the five-phase VSI in α - β sub-space

vectors available from a five-phase VSI. Using the first of (11) one determines the five-phase VSI space vectors in the α - β sub-space (Fig. 16). The 30 active vectors form three concentric decagons and the ratio of the amplitudes of the voltage vectors is $1 : 1.618 : 1.618^2$ from the smallest to the largest vector amplitude. The voltage vectors are to be selected according to the errors of the stator flux and torque ($\Delta\psi_s = \psi_s^* - \psi_s$ and $\Delta T = T_e^* - T_e$). Fig. 17 summarises the combined effects of each voltage vector on both the stator flux and torque, assuming the initial stator flux is located in the first sector [59, 60].

The 32 voltage space vectors are divided into three groups according to their amplitudes. The larger the voltage vector amplitude, the higher its influence is on the flux ψ_s and torque T_e . Within the set of active vectors of the same length (plus zero vectors) the relative impact on the stator flux and torque is illustrated in Fig. 17 with the number of arrows. Three arrows upward ($\uparrow\uparrow\uparrow$) or downward ($\downarrow\downarrow\downarrow$) represent the maximisation or minimisation of the flux ψ_s and torque T_e when these voltage vectors are applied. The arrow ($\uparrow\downarrow$) indicates that the flux stays nearly constant.

Since the fastest change in both flux and torque error will result if only large vectors are applied, this is the natural and simplest choice for the optimum voltage vector table. This

	V_6	V_{14}	V_{12}	V_{28}	V_{24}	V_{25}	V_{17}	V_{19}	V_3	V_7	$V_{0(32)}$
$\psi_{s(1)}$	$\downarrow\downarrow\downarrow$	$\downarrow\downarrow$	\downarrow	\uparrow	$\uparrow\uparrow$	$\uparrow\uparrow\uparrow$	$\uparrow\uparrow$	\uparrow	\downarrow	$\downarrow\downarrow$	$\uparrow\downarrow$
$T_{e(1)}$	\downarrow	$\uparrow\uparrow$	$\uparrow\uparrow\uparrow$	$\uparrow\uparrow\uparrow$	$\uparrow\uparrow$	\downarrow	$\downarrow\downarrow$	$\downarrow\downarrow\downarrow$	$\downarrow\downarrow\downarrow$	$\downarrow\downarrow$	\downarrow

	V_{15}	V_4	V_{30}	V_8	V_{29}	V_{16}	V_{27}	V_1	V_{23}	V_2	$V_{0(32)}$
$\psi_{s(2)}$	$\downarrow\downarrow\downarrow$	$\downarrow\downarrow$	\downarrow	\uparrow	$\uparrow\uparrow$	$\uparrow\uparrow\uparrow$	$\uparrow\uparrow$	\uparrow	\downarrow	$\downarrow\downarrow$	$\uparrow\downarrow$
$T_{e(2)}$	\downarrow	$\uparrow\uparrow$	$\uparrow\uparrow\uparrow$	$\uparrow\uparrow\uparrow$	$\uparrow\uparrow$	\downarrow	$\downarrow\downarrow$	$\downarrow\downarrow\downarrow$	$\downarrow\downarrow\downarrow$	$\downarrow\downarrow$	\downarrow

	V_{22}	V_{10}	V_{13}	V_{20}	V_{26}	V_9	V_{21}	V_{18}	V_{11}	V_5	$V_{0(32)}$
$\psi_{s(3)}$	$\downarrow\downarrow\downarrow$	$\downarrow\downarrow$	\downarrow	\uparrow	$\uparrow\uparrow$	$\uparrow\uparrow\uparrow$	$\uparrow\uparrow$	\uparrow	\downarrow	$\downarrow\downarrow$	$\uparrow\downarrow$
$T_{e(3)}$	\downarrow	$\uparrow\uparrow$	$\uparrow\uparrow\uparrow$	$\uparrow\uparrow\uparrow$	$\uparrow\uparrow$	\downarrow	$\downarrow\downarrow$	$\downarrow\downarrow\downarrow$	$\downarrow\downarrow\downarrow$	$\downarrow\downarrow$	\downarrow

Fig. 17 Stator flux and torque variations under different vectors

means that the applied phase voltage will be as shown in Fig. 9 and will therefore contain substantial amount of the third (and considerably smaller amount of the seventh) harmonic. If the machine is with a sinusoidally distributed winding, application of the large vectors only will cause substantial third harmonic stator currents since the impedance for this harmonic is a small stator leakage impedance (see (7) and (8)). However, in a machine with the concentrated stator winding the third stator voltage harmonic will in essence lead to an automatic third stator current harmonic injection (of considerably smaller value than in the case of the machine with sinusoidally distributed stator winding, since the impedance for the third harmonic is now much larger, due to the stator-to-rotor coupling). An illustration of the operation of the scheme of Fig. 15 in conjunction with the concentrated winding five-phase machine (already utilised in Section 5.2) is given in Fig. 18. Only the largest space vectors are utilised in the optimum voltage vector table and stator current and voltage of phase a are shown in steady-state operating conditions. As is evident from the voltage trace, there is a substantial amount of the low-order harmonics (the third and the seventh), commensurate with the waveform given in Fig. 9. The distortion in the stator current is however relatively small, because of the substantial impedance that the concentrated winding machine presents to the third stator voltage harmonic.

6 Asymmetrical six-phase induction motor drives

6.1 Introduction

The asymmetrical six-phase induction machine is a particular six-phase configuration where the stator has two sets of three-phase windings, spatially shifted by 30 electrical degrees (Fig. 19), while the rotor winding is of squirrel cage type and is the same as for a three-phase machine. This configuration is referred to in literature using different names, for example split-phase [73], dual three-phase (DTP) [31], double-star [30], dual-stator [55], and so on. It is undoubtedly the most frequently considered multiphase machine for high power applications. Since high current devices with high switching frequencies are not available yet, the sharing of the controlled power over a number of inverter legs is an alternative solution to the component paralleling to reduce the rated current of the power switches [35]. For the particular case of a six-phase drive, the rated

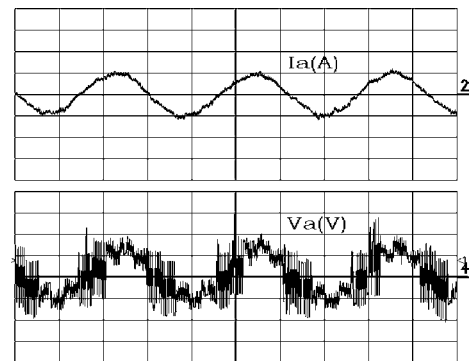

Fig. 18 Stator current and phase voltage of a concentrated winding five-phase induction machine, controlled using DTC scheme of Fig. 14 with the application of large vectors only (the first row of Fig. 16)

Scales: time = 8 ms/div, current = 2 A/div, and voltage = 20 V/div

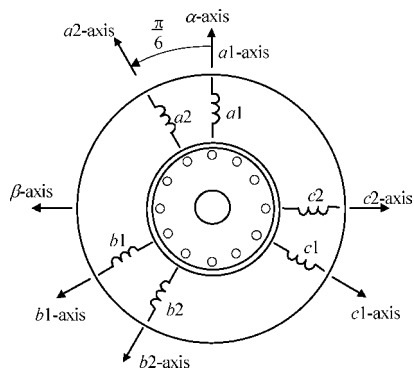

Fig. 19 Asymmetrical six-phase induction machine, illustrating magnetic axes of the stator phases

current of one switch is halved compared to a three-phase solution of the same power and phase voltage rating. Another benefit of the asymmetrical six-phase machine employing three-phase sets with isolated neutral points is related to the drive reliability. For example, a high-power traction drive for an Adtranz locomotive employing asymmetrical six-phase machines is described in [98, 99], where two independent three-phase inverters supply four asymmetrical six-phase induction motors in parallel. In case of failure of one inverter, the drive operates with the other, healthy inverter supplying the remaining three-phase stator winding set.

A survey of vector control and DTC solutions for VSI fed asymmetrical six-phase induction machines is provided further in this section. Theoretical considerations are accompanied with illustrative results, collected from an experimental set-up comprising a 10 kW, 40 V, 200 Hz machine prototype. The section concludes with a brief review of some very specific solutions/applications of six-phase induction motor drives.

6.2 Vector control of asymmetrical six-phase induction motor drives

Vector control schemes for the asymmetrical six-phase machine with sinusoidally distributed windings are obtained by referring the α - β machine model to a rotating d - q reference frame, normally aligned with the rotor flux. As discussed in Section 3.2, the α - β equations are obtained using either VSD approach [31] or the 'double d - q winding representation' theory [33], called here for simplicity DTP approach. A detailed comparison of the equivalent machine circuits in the stationary α - β reference frame along with the machine equations obtained using both VSD and DTP approaches is available in [100].

An indirect rotor FOC scheme, which follows the principles discussed in Section 3.3 in conjunction with Fig. 2, is presented in [48]. However, for applications requiring high fundamental frequencies and/or when the speed sensor does not provide sufficient accuracy of rotor position, direct rotor field oriented control (DRFOC) is usually preferred [36]. The rotating d - q reference frame is aligned with the rotor flux space vector whose magnitude ψ_r and position ϕ_r are provided by a flux estimator, as shown in Fig. 20.

The flux estimation required for field orientation is based on either VSD or DTP machine models [100]. When VSD machine model is used, the FOC scheme adopts flux estimators normally employed for the three-phase induction machines since the α - β machine model is identical to the model of a three-phase machine. In contrast to this,

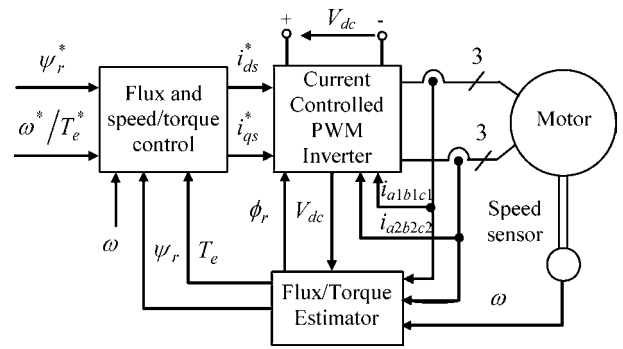

Fig. 20 DRFOC scheme for asymmetrical six-phase induction machine

the extension of current control strategies from the three-phase to the asymmetrical six-phase drive is less straightforward since it must consider some machine-specific aspects. In particular, small inherent asymmetries between the two three-phase power sections can lead to current imbalance between the two stator winding sets, as shown in [36, 42, 49]. This problem can appear when the machine is supplied from two independent three-phase inverters, a natural choice for industry applications. In such a case the scheme of Fig. 3, with only two current controllers, cannot guarantee a satisfactory performance. In principle, current control can be implemented either in the stationary or in the synchronous reference frame, depending on the required current control performance for the considered specific application. However, a minimum of four current controllers (assuming isolated neutral points) is necessary.

A DRFOC scheme, based on DTP machine modelling, is discussed in [35] in conjunction with a GTO inverter-fed high-power machine. The current control uses a double d - q synchronous reference frame approach (i.e. two pairs of d - q synchronous current controllers) to simultaneously control the flux-producing stator current components (i_{ds1} , i_{ds2}) and the torque-producing components (i_{qs1} , i_{qs2}) that correspond to the two three-phase stator winding sets. A decoupling scheme for current regulation, based on the machine's state-space model, has also been proposed. Another DRFOC scheme, based on the VSD theory (which gives a simpler rotor flux estimation) and also using the double d - q current control, is discussed in [36], while a comparison of different d - q synchronous frame current regulation schemes is available in [37].

The basic double d - q current control scheme is illustrated in Fig. 21a. When the neutral points of the two three-phase stator sets are connected, the control scheme must be complemented with additional PI current regulator since the system order increases from 4 to 5, as described in [42]. The double d - q synchronous reference frame current control for the asymmetrical six-phase drives has the disadvantage of the multiple speed-dependent coupling terms, which have to be compensated [37]. For this reason, a straightforward current control scheme in stationary α - β reference frame has been proposed in [50]. This scheme (Fig. 21b) does not require decoupling circuits and it is able to cope with the current imbalance between the two three-phase stator winding sets. The α - β current components are regulated by means of a stationary frame regulator being equivalent to a PI regulator in the d - q reference frame. If there is some imbalance and only α - β current controllers are utilised, fundamental current components appear in the x - y subspace as well (Fig. 22a). These components can be forced towards zero (thus cancelling the current imbalance) by two resonant regulators tuned on the fundamental

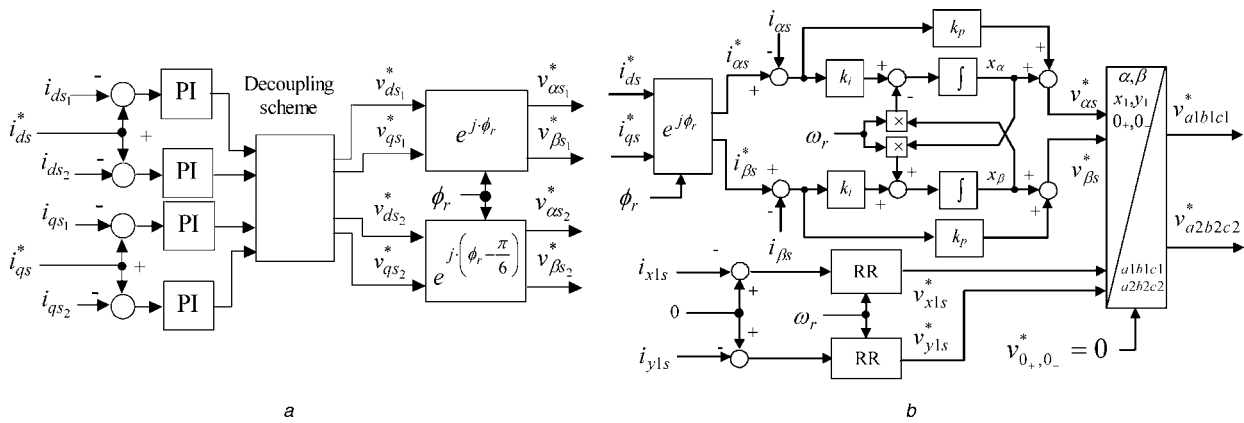

Fig. 21 Current control for asymmetrical six-phase induction machine, using four current controllers

- a Double (d, q) synchronous frame current control
- b Stationary reference frame current control

frequency (Fig. 21b) and controlling the x – y current components (Fig. 22b). This scheme requires online electrical angular speed estimation; that can be done, for example, by means of a phase-locked loop scheme (PLL) [50].

Provided that the current control scheme performs well, the behaviour of the vector-controlled asymmetrical six-phase induction motor drive is rather similar with that obtained for a three-phase induction machine. As an example, the load rejection behaviour of the drive for rated speed and rated load conditions is shown in Fig. 22c. The drive has been tested by imposing to the drive a start-up from standstill up to 2000 rpm (limit of the constant torque region), followed by step load torque transients of 50 Nm (machine rated torque). The current control scheme was implemented in stationary frame using the scheme of Fig. 21b. If double d – q current

control is utilised the drive behaviour is practically the same [37].

As noted, if the stator neutral points are not connected, the machine is a fourth order system and for this reason at least four current controllers are required, meaning that four current sensors are normally needed as well. However, the particular stator winding configuration in this machine allows utilisation of a reduced number of current sensors compared to other multiphase solutions, without affecting the system performance. That is possible only if the machine is supplied by a dedicated six-phase inverter, in order to avoid current imbalance between the two three-phase stator sets. Under such conditions, a vector control scheme, employing only two current sensors (sized for 50% of the rated current of an equivalent three-phase drive of the same power), is presented in [101].

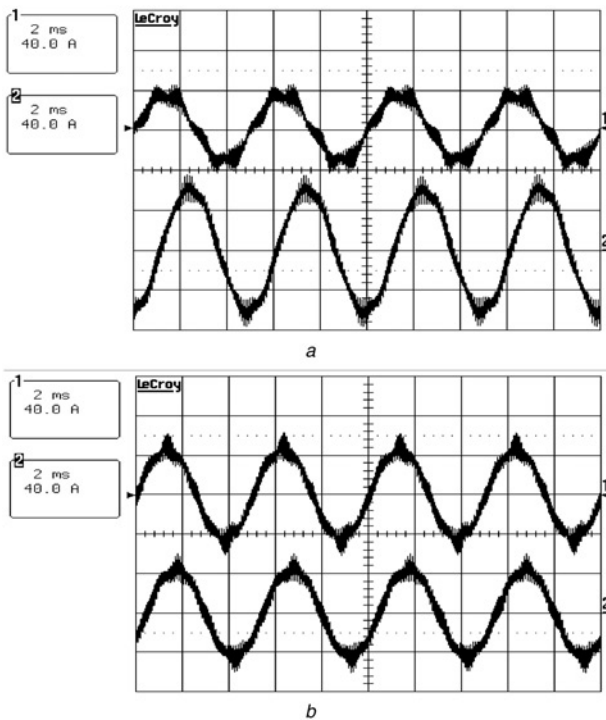

Fig. 22 Current control in the stationary reference frame

- a Using only one pair (α – β) of current controllers
- b Using two pairs (α – β and x_{1s} – y_{1s}) of current controllers
- c Load rejection drive performance using two pairs of current controllers: (1) n^* (rpm); (2) n (rpm); (3) i_{ds} (A); (4) i_{qs} (A); (5) T_e (Nm)

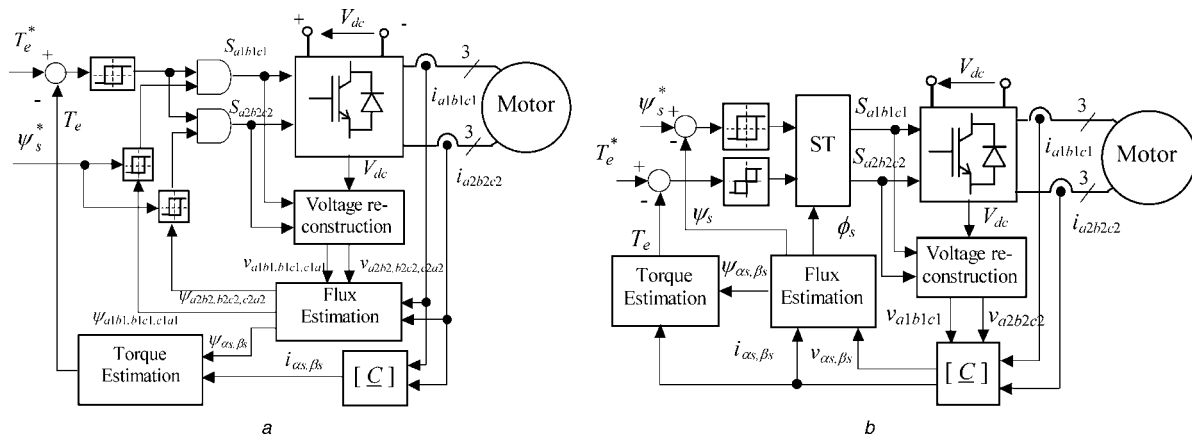

Fig. 23 Control schemes for an asymmetrical six-phase induction motor drive.

- a Basic DSC scheme
- b Basic DTC-ST scheme

The current sensors are positioned in phases belonging to two different three-phase sets ($a1$ and $c2$, respectively), shifted by 90° electrical degrees, so that the measured currents are equal to the stator current α - β components, except for a scaling factor (see Fig. 19; using (10) and assuming balanced two three-phase sets of currents one gets $i_{\alpha s} = \sqrt{3}i_{a1}$, $i_{\beta s} = \pm\sqrt{3}i_{c2}$ where the sign of β -axis component depends on the sign of the 30° spatial shift between the two three-phase windings).

6.3 DTC of asymmetrical six-phase induction motor drives

As discussed in Section 3.4, conventional DTC schemes for three-phase induction motor drives can be extended to multiphase drives. This applies to both direct self-control (DSC) and switching table-based DTC (ST-DTC). These two schemes are illustrated in Fig. 23 for an asymmetrical six-phase induction motor drive. The similarity of the ST-DTC scheme with the one of Fig. 15 for a five-phase induction machine is obvious. By using the voltage vectors corresponding to the external layer of the dodecagon in the α - β subspace (12 largest vectors) [100], the DSC imposes a 12-sided polygonal trajectory of the stator flux. This is achieved at the expense of generation of the fifth and seventh voltage harmonics; these harmonic voltages will in turn produce large current harmonics in the x - y subspace, as shown by the detailed simulation study of the DSC scheme in [57].

In the ST-DTC scheme of Fig. 23b, based on the estimated stator flux position, a torque three-level hysteresis regulator and a flux two-level regulator are used to generate the inverter switching functions through an optimal ST. As already emphasised in conjunction with hysteresis-based DTC of the five-phase machine, the key issue for ST-DTC is the ST design to obtain sinusoidal machine phase currents, by minimising the current components in the x - y subspace. Different ST design solutions are discussed and experimentally investigated in [61]. Good torque and flux regulation performance have been demonstrated but the phase currents distortion problem has not been solved completely. This issue has been already addressed in Section 3.4.

The problem of phase currents distortion can only be completely solved for the asymmetrical six-phase machine by keeping the switching frequency constant and imposing the direct mean torque control approach. In this case, an average stator voltage reference vector over a sampling period must be computed and imposed using a suitable

PWM technique in order to achieve the reference stator flux and electromagnetic torque (PWM-DTC). The basic PWM-DTC scheme is shown in Fig. 24.

A predictive PWM-DTC scheme, using the VSD theory for machine modelling, has been proposed in [57] to obtain sinusoidal machine currents. The algorithm has been implemented in stator flux oriented reference frame. Another PWM-DTC scheme, based once more on the VSD theory, is presented in [102]. The reference voltage vector is obtained through simple PI regulators implemented in the stator flux oriented reference frame. The stator flux is estimated by means of a full-order Luenberger observer, which provides also stator current estimation. The estimated currents (that are less noisy than the real ones) are used to successfully compensate the inverter dead-time effects, improving significantly the drive performance at very low speed [102].

Transient behaviour of a PWM-DTC scheme with speed control and employing the Luenberger observer for flux estimation is illustrated in Fig. 25. The drive transient response to triangular speed reference is shown in Fig. 25a, whereas Fig. 25b shows the drive start-up from standstill to 6500 rpm ($\cong 650$ Hz) followed by a speed reversal. The stator flux reference computation takes into account the DC link voltage variations during acceleration and braking. The machine phase currents are practically sinusoidal, as illustrated in Fig. 26a for drive operation at high speed (450 Hz) with maximum developed torque. The drive behaviour at very low speed is improved due to the inverter dead-time compensation using the estimated currents (by the Luenberger observer) instead of the measured ones. The inverter dead-time effects compensation efficiency is demonstrated in Fig. 26b for drive operation at 1 rpm ($\cong 0.1$ Hz).

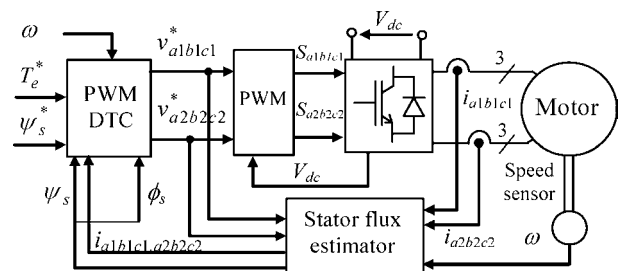

Fig. 24 Basic PWM-DTC scheme for asymmetrical six-phase induction motor drives

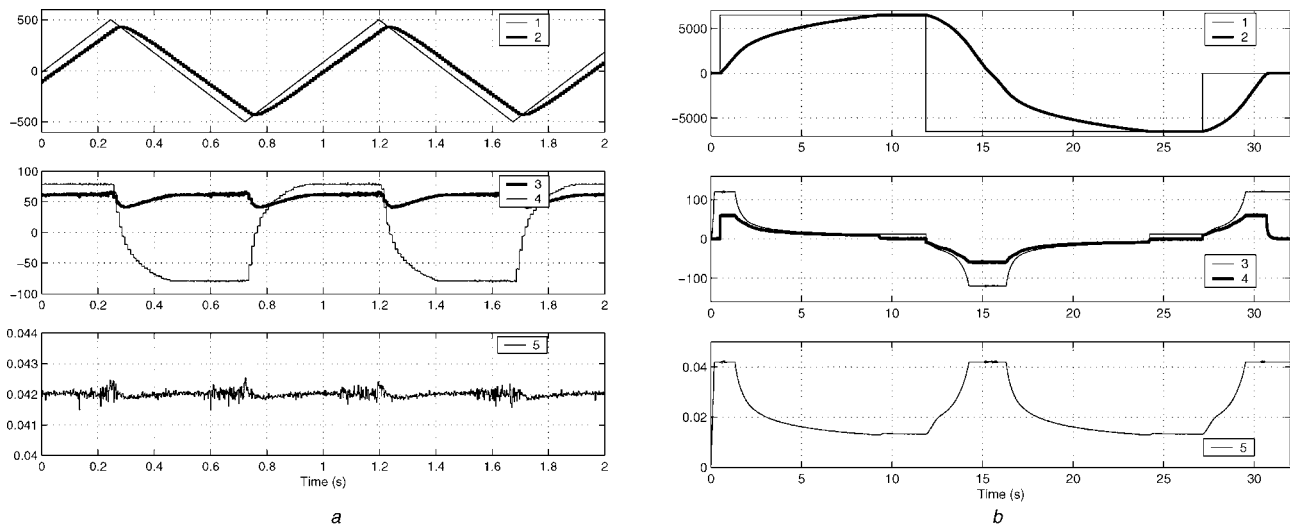

Fig. 25 Transient drive performance for PWM-DTC using Luenberger observer for flux estimation
a Triangular reference speed drive response: (1) n^* (rpm); (2) n (rpm); (3) i_{ds} (A); (4) i_{qs} (A); (5) ψ_s (Vs)
b Drive start-up and speed reversal: (1) n^* (rpm); (2) n (rpm); (3) pull-out torque T_{pull_out} (Nm); (4) T_e (Nm); (5) ψ_s (Vs)

In summary, the majority of the available work deals with the development of control schemes for asymmetrical six-phase induction motor drives starting from the well-known three-phase solutions. The transition from three-phase to asymmetrical six-phase machine control, however, requires more dedicated solutions and this is well recognised nowadays. In particular, to avoid possible stator current distortion and unbalanced current sharing between the two stator three-phase winding sets, specific approaches regarding machine modelling, inverter modulation techniques and current control schemes have been developed and experimentally investigated.

Novel control concepts, not realisable with three-phase machines and therefore specific only to multiphase drives, are related to the employment of certain properties of asymmetrical six-phase machines in particular applications, such as single-inverter two-motor drives with independent control [103] (described in more detail in Section 8) and dual-source motor drives [104]. In the latter case, two three-phase inverters with separate DC links supply an asymmetrical six-phase machine. The proposed drive topology allows the addition, directly at the machine level, of the power generated by independent DC voltage sources

without employing additional DC–DC converters. In this case, different amounts of power can be drawn from the two independent DC links, depending on the working conditions and the rated power of these two sources [104]. The proposed control can be extended also to the symmetrical six-phase induction machine. As a possible application, it has been considered in conjunction with the hybrid fuel cell (FC) electrical vehicles, where an FC and a battery can supply the two three-phase inverters [104].

6.4 Some specific solutions with six-phase induction motor drives

A particular problem encountered in electric vehicle applications of induction motor drives is the need for extended field-weakening operating region. This can be realised by utilising a six-phase induction machine in conjunction with electronic pole number changing [105, 106]. The development described in [105, 106] is related to propulsion. A similar idea, but for an integrated starter/alternator, has been explored in [107] where one of the considered arrangements has included six-phase winding with four poles and three-phase winding with 16 poles.

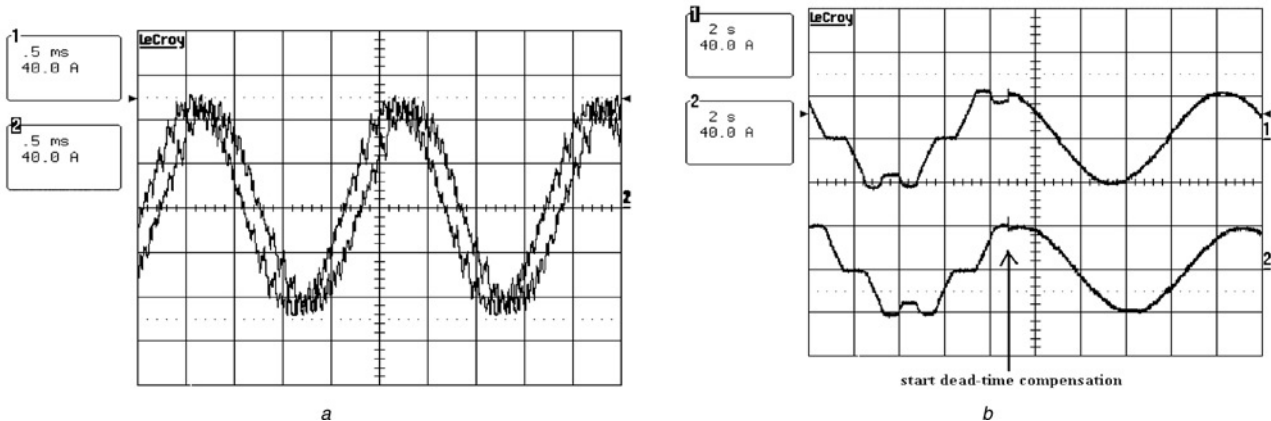

Fig. 26 Machine stator currents using PWM-DTC
a Machine phase currents at high speed (≈ 450 Hz) with full torque. Trace 1: i_{a1} (A), Trace 2: i_{a2} (A)
b Stator currents at 1 rpm (≈ 0.1 Hz) without and with dead-time compensation. Trace 1: i_{a1} (A); Trace 2: i_{a2} (A)

The endings of the asymmetrical six-phase induction motor winding can be left deliberately open (rather than connected into the star point(s)), resulting in the so-called open-end winding configuration. This enables supply of the machine's stator winding from both sides and requires two asymmetrical six-phase (or four three-phase) VSIs [108]. The advantage of such a solution is that suppression of low-order voltage harmonics becomes relatively easy. However, the scheme requires doubling of the number of switches, when compared to the traditional one. Schemes that go in the opposite direction and therefore worsen the performance by looking at the six-phase motor supply from an inverter or rectifier/inverter with a reduced switch count have also been developed for both asymmetrical six-phase induction machine [109] (VSI with five or four legs, rather than six) and symmetrical six-phase induction machine [110] (controllable rectifier/VSI with 8, 10 and 12 switches instead of full configuration with 18 switches). The main disadvantage of such reduced switch count schemes is in principle the reduction of the maximum achievable fundamental output voltage for the given DC link voltage, when compared to the full switch count configuration.

Means for keeping a multiphase machine operational in post-fault conditions are elaborated in Section 7. These by and large rely on control algorithm modification (i.e. software re-configuration), so that in post-fault operation one or more phases of a multiphase machine are not supplied from the inverter any more. A rather different approach, in which a hardware re-configuration takes place, is described in [111] for an asymmetrical six-phase induction machine. In the case of a fault of one inverter leg, the phase that would be left without supply in post-fault operation if software re-configuration is applied gets connected to one of the remaining healthy inverter legs (so that two motor phases are now supplied from the same inverter leg) using additional semiconductors (triacs) for this re-configuration.

7 Fault tolerance

In a three-phase induction motor, should one phase of the motor or the inverter be rendered inoperable, the currents in the remaining two phases become identically equal in magnitude with 180° phase displacement if the machine is star-connected with isolated neutral point. Hence independent control of the two remaining currents becomes impossible, unless a divided DC bus and neutral connection are provided [112]. In other words, a zero-sequence component is necessary in a three-phase induction motor to provide an undisturbed rotating magneto-motive force after one supply phase is opened [112]. The situation is, as explained in Section 2, very different in multiphase motor drives, where existence of more than three phase currents (with only two being required for the machine control) enables development of various strategies for post-fault operation, without the need for the neutral connection and the split DC bus. This property of multiphase motor drives was recognised in the early days of their development [113] and is one of their most beneficial features. In essence, there exists phase redundancy and for an n -phase machine normal operation will still be possible for all fault conditions that include failure of any number of phases up to the $n - 3$. The machine can still continue to operate in post-fault conditions with the rotating magneto-motive force, provided that an appropriate post-fault current control strategy is developed. In essence, the existing degrees of freedom that were used in Section 5.2 to enhance torque

production by higher stator current harmonic injection are now utilised to design post-fault control strategies.

Such a control strategy can be developed for any multiphase machine with a single neutral point. However, if the machine is designed as $n = ak$ phase machine ($a = 3, 4, 5, 6, 7, \dots, k = 2, 3, 4, 5, \dots$) and the complete winding is configured as k windings with a phases each, with k isolated neutral points and k independent a -phase inverters, then the simplest post-fault strategy can be utilised. It consists of taking out of service the complete a -phase winding in which fault has taken place, regardless of the number of affected phases within that particular winding. For example, in the case of a six-phase machine with two isolated neutrals, if one three-phase winding is taken out of service the machine can continue to operate without any control algorithm modification using the remaining healthy three-phase winding, of course with the available torque and power reduced to one half of the rating (assuming no increase in the current in the healthy phases). This is a perfectly satisfactory solution in for example traction applications [98, 99]. Similarly, the 15-phase induction machine for ship propulsion of [27, 28], configured with three five-phase stator windings, can continue to operate with one or two five-phase windings in faulted operation.

Design of a strategy for post-fault operation is usually preceded by an analysis of the fault impact on the drive behaviour. The analysis is most frequently based on simulations using models of the type described in Section 3.2. For example, a detailed study of the asymmetrical six-phase (synchronous rather than induction) machine, using both the modelling approach detailed in Section 3.2 and the double $d-q$ modelling approach, has been reported in [114], while double $d-q$ modelling approach has been used for the same purpose in conjunction with asymmetrical six-phase induction machine in [115]. Detailed analysis of a nine-phase symmetrical induction motor drive with single neutral point under various fault conditions (simultaneous opening of up to three phases) has been presented in [116] where effects on motor currents, rotor flux, slip and torque ripple have been studied assuming continuous operation with rated torque in post-fault conditions. Some further comparative analysis has also been performed for 6-, 9-, 12-, 15- and 18-phase symmetrical machines, with a conclusion that single neutral point gives better characteristics in post-fault operation than the configuration with k isolated neutral points. This is so since single neutral point enables utilisation of all the healthy phases for post-fault control, while in the case of the isolated neutral points one has to take out of service the complete faulty three-phase winding(s).

Although relatively simple circuit modelling usually suffices for the studies related to the design of fault tolerant strategies, it is also possible to use more complex induction machine representations. For example, the study reported in [117] represents the machine with the dynamic reluctance mesh model, thus enabling more precise description of secondary effects and hence more accurate simulation analysis. Of course, if one wants to study internal faults within the machine simple circuit modelling approach has to be replaced with a more appropriate and more complicated method. One such tool is the generalised harmonic analysis, utilised in [118] to study the multiphase induction machine winding faults.

The problem of designing the post-fault operating strategy in essence reduces to finding the required relationship between the currents of remaining healthy phases, so that operation with a rotating magneto-motive force is still obtained, although the winding itself is now asymmetrical. An additional criterion has to be specified, since operation

with reduced number of phases essentially means that currents in the remaining phases have to increase if the developed torque is to be maintained at the pre-fault level [12, 119]. This leads to an increase in the stator winding loss and may cause overheating if the operation is sustained for a prolonged period of time. For example, if full load torque is maintained after loss of one phase in 6-, 9-, 12-, 15- and 18-phase induction motor drives, the stator loss will increase by the amounts listed in Table 4, respectively. Hence one additional criterion can be that, as discussed in Section 2, the post-fault stator loss remains at the pre-fault level [12, 119]. This will inevitably lead to a torque loss, which however will be smaller and smaller as the number of phases increases (with improvement becoming negligible above 12 phases) [12, 119].

Most of the detailed studies related to post-fault control strategy design have been conducted for asymmetrical six-phase and five-phase induction machines. Probably the most complete study of an asymmetrical six-phase induction machine with single neutral point under the condition of the loss of one phase has been reported in [120, 121]. VSD approach to modelling has been utilised and the complete rotor FOC scheme for operation in post-fault conditions has been developed and experimentally verified. Post-fault current control involves two pairs of current controllers in two sub-spaces of the five-dimensional (post-fault) space (this being in principle similar to the stationary reference frame current control discussed in Section 6.2). Excellent dynamics in post-fault operation have been demonstrated with the system of very asymmetrical remaining five stator phase currents. Further studies related to the post-fault control strategy design and operation of an asymmetrical six-phase machine with isolated neutral points under the loss of one, two and three inverter legs and assuming V/f control are available in [122].

Post-fault current control strategies for a five-phase induction motor drive have been developed in [123, 124]. The zero-sequence current, in contrast to a three-phase machine, is no longer needed to provide the undisturbed rotating magneto-motive force. After losing up to two phases, the five-phase induction motor can continue to operate steadily under closed loop control. The resilient current control thus eliminates the use of a neutral connection and provides the same rotating magneto-motive force to ensure smooth motor operation as under the normal conditions. Suppose that, prior to the fault, the five-phase machine operated with a balanced sinusoidal system of currents such that phase a current was $i_{as} = I_{\max} \cos \omega t$. Let there be open-circuiting of phase a . In post-fault operation the remaining four phase currents have to be regulated to

$$\begin{aligned} i'_{bs} &= \frac{5I_{\max}}{4(\sin \frac{2\pi}{5})^2} \cos\left(\omega t - \frac{\pi}{5}\right) \\ i'_{cs} &= \frac{5I_{\max}}{4(\sin \frac{2\pi}{5})^2} \cos\left(\omega t - \frac{4\pi}{5}\right) \\ i'_{ds} &= \frac{5I_{\max}}{4(\sin \frac{2\pi}{5})^2} \cos\left(\omega t + \frac{4\pi}{5}\right) \\ i'_{es} &= \frac{5I_{\max}}{4(\sin \frac{2\pi}{5})^2} \cos\left(\omega t + \frac{\pi}{5}\right) \end{aligned} \quad (15)$$

to produce a smooth forward rotating magneto-motive force under the condition that the current magnitude in all the remaining healthy four phases is equal [124]. As already noted, different conditions may be imposed in order to find the required post-fault currents (Section 2). It is

important to notice that the currents given by (15) can generate the same magneto-motive force as in the healthy case with the same level of torque. However, if the machine is running at rated torque then once a phase is lost the remaining four phases need to be regulated such that the maximum current level of each phase is not jeopardised. This means that the machine will operate with a smooth torque at reduced average torque level. It is also possible to analyse in the same manner the fault where two phases become open-circuited and determine the required phase current variation law for the remaining three healthy phases [124].

As an illustration, Fig. 27 depicts motor speed and currents of phases a , b and c after open-circuiting of phase a . The fault takes place under loaded conditions. It can be observed that the motor speed response is very stable and that the currents in the remaining healthy phases are greatly increased. Hence, if the fault takes place from rated load torque operation, post-fault conditions of Fig. 27 should not be allowed to persist for a prolonged period of time, to avoid overheating. If the load can be controlled, then the motor can continue to operate indefinitely using this post-fault strategy by reducing the torque to a safe (lower) level.

Very much the same considerations apply if two phases receive open-circuited, so that the machine continues to operate on three phases only. Experimental results for this case are shown in Fig. 28, when phases a and b are opened successively, for operation under no-load conditions. Clearly, both speed and torque are essentially stable when the faults occur, but the remaining three phase currents become very asymmetrical and have substantially increased magnitudes although the operation is under no-load conditions.

The approach to designing the fault tolerant strategy in principle follows the same methodology, regardless of the type of the machine and the number of phases. The result given in (15) has also been confirmed in [125, 126], where an approach based on the symmetrical component (Fortescue's) theory has been utilised, and where operation with one open-circuited phase was studied for both the condition of the equal post-fault currents in the remaining healthy phases (as in (15)) and for the post-fault operation with the minimised stator winding losses. Further studies related to fault tolerant control of a five-phase induction machine have been reported for the case of V/f control in [127], while five-phase permanent magnet synchronous machine has been covered in [128, 129]. Fault tolerant

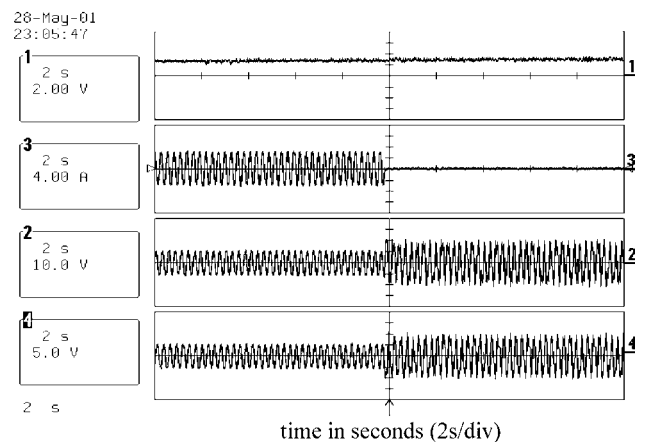

Fig. 27 Experimental results of the fault tolerant control of a five-phase induction motor (phase 'a' open-circuited under loaded conditions)

From top to bottom: speed (120 rpm/div), phase 'a' current (4 A/div), phase 'b' current (4 A/div) and phase 'c' current (4 A/div)

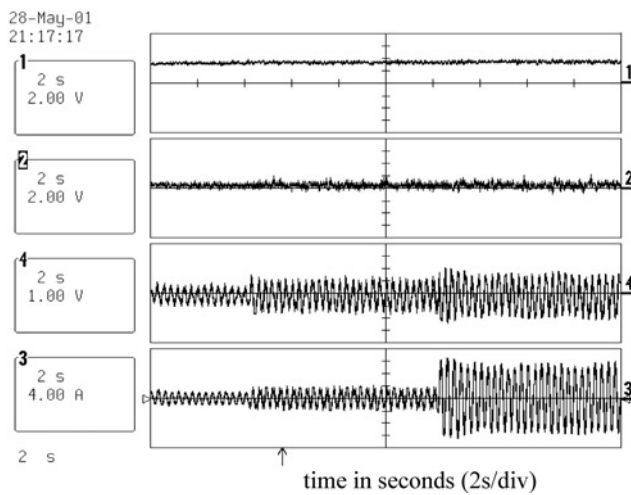

Fig. 28 Experimental results of the fault tolerant control of a five-phase induction motor (phases 'a' and 'b' successively open-circuited under no-load conditions)

From top to bottom: speed (120 rpm/div), torque (25 lb-in/div), phase 'c' current (4 A/div) and phase 'd' current (4 A/div)

strategies for a seven-phase brushless DC machine have been developed in [130]. It should at this point be noted that the considerations given here are restricted to multiphase induction machines with concentrated and sinusoidally distributed windings. Drive systems, based on permanent magnet or brushless synchronous machines and aimed at safety-critical applications such as aerospace and 'more-electric' aircraft, are often designed using so-called modular design, where the phases are isolated and independent magnetically, electrically, thermally and mechanically. Individual H-bridge inverters are normally used for such drive systems. Although the method to design fault-tolerant strategies is in principle the same, multiphase drives of this type are characterised with a number of special features and are beyond the scope of this paper (for further information see [131–136]).

8 Multiphase multi-motor drive systems with single inverter supply

Since independent flux and torque (vector) control of an AC machine, regardless of the number of phases, requires only two currents, additional degrees of freedom that exist in multiphase machines can be used to enhance the torque production by stator harmonic current injection or to improve the fault tolerance. An alternative use of these additional degrees of freedom is to form a multi-motor drive system with single inverter supply. This control strategy is restricted to multiphase machines with sinusoidal flux

distribution. Stator windings of the machines are connected in series, using phase transposition, so that flux/torque producing ($d-q$) currents of one machine appear as non-flux/torque producing ($x-y$) currents for all the other machines and vector control is applied. This enables completely decoupled and independent control of the machines, although they are connected in series and a single VSI is used as the supply. The initial proposal was related to the five-phase series-connected two-motor drive [90]. However, the principle is applicable to any inverter phase number and it has been developed into considerable depth for all symmetrical multiphase VSIs with even phase numbers and with odd phase numbers in [137] and [138], respectively. The number of machines connectable in series is at most $k = (n - 2)/2$ for even supply phase numbers and $k = (n - 1)/2$ for odd supply phase numbers. Whether or not all the series-connected machines are of the same phase number depends on the supply phase number [137, 138]. The possibility of series connection exists also in the case of asymmetrical machines and it has been developed in [103, 139, 140] for asymmetrical six-phase case and in [32] for asymmetrical nine-phase case. Asymmetrical six-phase supply enables series connection of either two asymmetrical six-phase machines [103, 139, 140] or one asymmetrical six-phase machine and a two-phase machine [140]. The latter possibility has a drawback in that it requires the neutral of the drive system to be connected either to the seventh inverter leg or to the mid-point of the DC link [140]. On the other hand, the properties of the former are practically the same as for the two-motor five-phase drive.

From the application point of view two potentially viable solutions appear to be two-motor series-connected five-phase (or asymmetrical six-phase, comprising two asymmetrical six-phase machines) and symmetrical six-phase induction motor drives. The connection schemes for the five-phase and the symmetrical six-phase supply are illustrated in Fig. 29. In the six-phase configuration the second machine is three-phase and it is not in any way affected by the series connection. Since flux/torque producing currents of the three-phase machine flow through the six-phase machine's stator winding, impact of the series connection on the six-phase machine will be negligible provided that the six-phase machine is of a considerably higher rating than the three-phase machine. In contrast to this, in five-phase (and asymmetrical six-phase) configuration both machines are affected by the series connection since flux/torque producing currents of each machine flow through both machines. Hence the potential applicability of this configuration is related to either two-motor drives where the two machines never operate simultaneously or where the operating conditions are at all times very different (for example, two-motor winder drives, [53]). More detailed

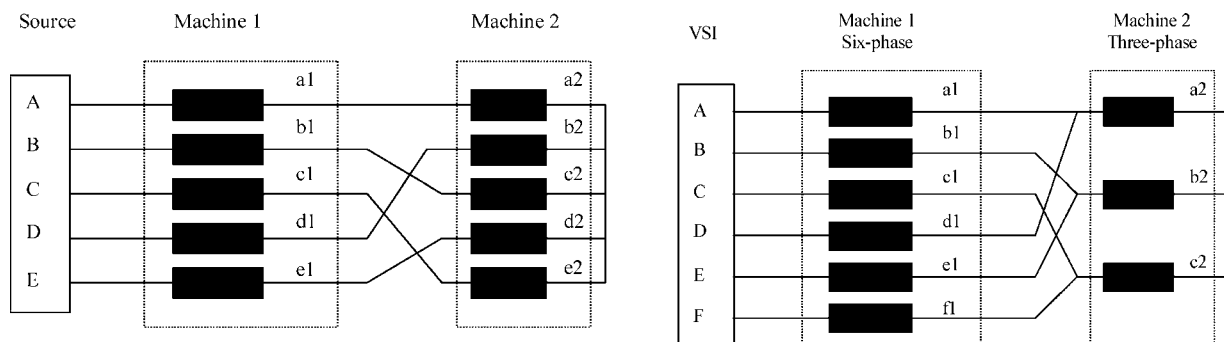

Fig. 29 Series-connected two-motor five-phase and six-phase induction motor drives

considerations related to various aspects of symmetrical six-phase and five-phase series-connected two-motor drives are available in [140, 141] and [53, 142, 143], respectively. Experimentally recorded transient behaviour of the five-phase two-motor drive is illustrated in Fig. 30. One machine operates with constant speed reference of 500 rpm, while the other machine is decelerated from 800 rpm to standstill. As can be observed from the responses in Fig. 30, the machine which runs at constant speed is not disturbed at all by the transient of the other machine, indicating full decoupling of control of the two machines.

One shortcoming of the series arrangement of Fig. 29 is the need to bring out to the terminal box of an n -phase machine both the beginning and ending of each phase. An alternative, that circumvents this problem, is utilisation of parallel connection of multiphase machines, while still using a single multiphase inverter for the supply of the machine group. The same type of phase transposition is still required when connecting the machines, as illustrated in Fig. 31 for the two-motor parallel connected five-phase drive [144]. Parallel connection is, to start with, much more restrictive than the series connection. It can only be realised when the system (VSI) number of phases is an odd prime number (i.e. when all the machines that are connected to the same VSI are of the same phase number) [144]. Further, if parallel connection is used, then the current control should be performed in the rotating reference frame (in contrast to series connection, where the

most natural choice is current control in the stationary reference frame) and the output of the control system are inverter voltage references, created in essence in the same manner as the inverter current references are created for the series connection [144, 145]. While parallel connection looks more attractive than the series connection at the first sight, it suffers from some serious disadvantages that make it far inferior to the series connection. First of all, the DC link voltage in the series connection is split across machines connected in series, while in parallel connection each of the machines is subjected to the full DC link voltage (as is obvious from Figs. 29 and 31, DC link voltage has to be substantially increased, almost doubled, compared to the single motor drive, [69]). More importantly however, in series connection all inverter current components are directly controlled and therefore known. In contrast to this, in parallel connection it is the inverter voltage components that are directly controlled, leading to essentially uncontrollable stator x - y current components in machines of the group. Steady-state analysis of the operation of five-phase two-motor series-connected and parallel-connected drives reported in [146] and [145], respectively, offers detailed explanation of this problem. The net result is that, although fully decoupled dynamic control of all the machines of the multi-motor drive is possible using both series and parallel connection, it is only the series connection that holds prospect for industrial applications.

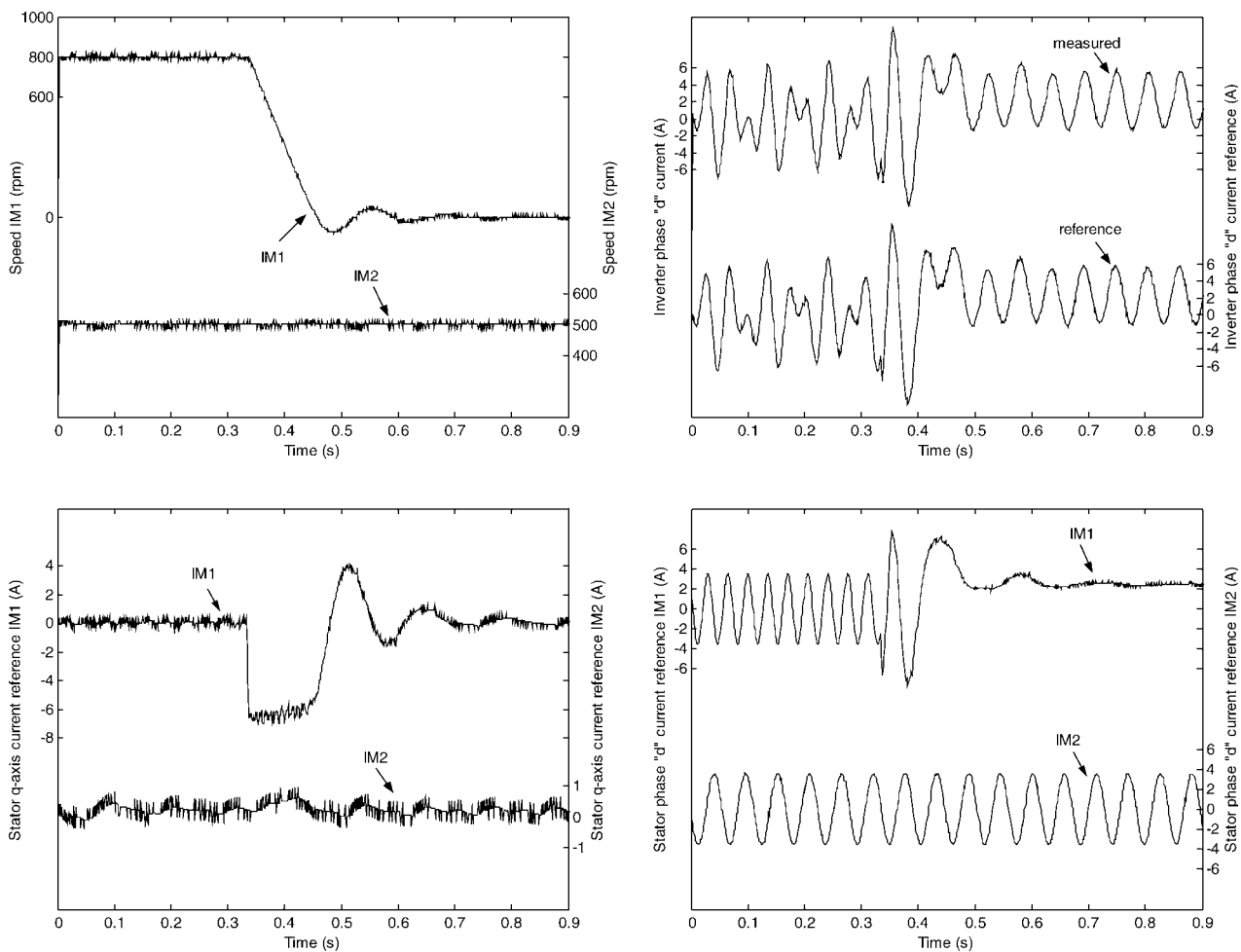

Fig. 30 Transient operation of a series-connected five-phase two-motor drive: speed responses, stator q -axis current commands (peak), comparison of measured and reference current for one inverter phase and current references for one phase of the two machines (machine 2 (IM2) runs at 500 rpm, while machine 1 (IM1) decelerates from 800 to 0 rpm)

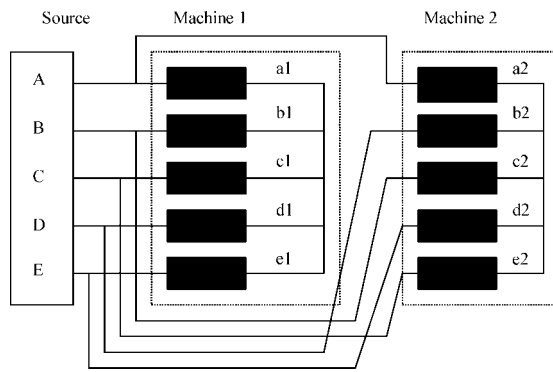

Fig. 31 Five-phase parallel-connected two-motor drive

9 Instead of conclusion

An attempt has been made in this paper to review state-of-the-art and highlight recent developments in the area of multiphase induction motor drives. As with any other rapidly moving area, no survey can ever be complete and the authors apologise to all the researchers whose important work may have been overlooked. It should also be noted that the references included in this paper have a cut-off date of Spring 2006, when the work on this paper commenced.

Multiphase machines are currently being used where both the machine and its control electronics are designed as a system, rather than as individual components. They have been found to be ideally suited, for example for the direct drives in marine applications, where their fault tolerance, high efficiency, low acoustic noise and the ability to distribute the drive electronics are seen as particularly advantageous. The 15-phase induction motor drive for ship propulsion, covered in references [25–29] of the paper, is now available on the market. A somewhat specific (and therefore not covered in more detail) multiphase drive configuration, described in [147], has undergone field trials as a possible solution for moving airplanes on the ground by means of on-board electric motors and is also considered as a potentially viable solution for an integrated starter/alternator set. In all likelihood, variable-speed multiphase drives will gain industrial acceptance in future in other applications where their advantages outweigh the lack of the off-the-shelf availability of both machines and power electronic converters.

The authors believe that the paper will be useful for all those already engaged in the research on multiphase motor drives in general and multiphase induction motor drives in particular, as well as for complete novices in this field who are currently embarking on research in this exciting sub-area of variable-speed electric motor drive control.

10 Acknowledgment

The authors are indebted to their numerous PhD students and post-doctoral research associates, whose diligent work has enabled construction of various experimental rigs used for the illustrations in this paper. Without their effort this paper would have not been possible.

11 References

- 1 Ward, E.E., and Härer, H.: 'Preliminary investigation of an inverter-fed 5-phase induction motor', *Proc. IEE.*, 1969, **116**, (6), pp. 980–984
- 2 Singh, G.K.: 'Multi-phase induction machine drive research – a survey', *Electr. Power Syst. Res.*, 2002, **61**, pp. 139–147

- 3 Jones, M., and Levi, E.: 'A literature survey of state-of-the-art in multiphase AC drives'. Proc. Universities Power Engineering Conference UPEC, Stafford, UK, 2002, pp. 505–510
- 4 Hodge, C., Williamson, S., and Smith, A.C.: 'Direct drive marine propulsion motors'. Proc. Int. Conf. on Electrical Machines ICEM. Bruges, Belgium, 2002, CD-ROM paper 087
- 5 Smith, S.: 'Developments in power electronics machines and drives', *IEE Power Eng. J.*, 2002, **16**, pp. 13–17
- 6 Gritter, D., Kalsi, S.S., and Henderson, N.: 'Variable speed electric drive options for electric ships'. Proc. IEEE Electric Ship Technologies Symposium ESTS, Philadelphia, PA, 2005, pp. 347–354
- 7 Golubev, A.N., and Ignatenko, S.V.: 'Influence of number of stator-winding phases on the noise characteristics of an asynchronous motor', *Russ. Electr. Eng.*, 2000, **71**, pp. 41–46
- 8 Klingshirn, E.A.: 'High phase order induction motors—Part I—Description and theoretical considerations', *IEEE Trans. Power Appar. Syst.*, 1983, **102**, (1), pp. 47–53
- 9 Weh, H., and Schroder, U.: 'Static inverter concepts for multiphase machines with square-wave current-field distribution'. Proc. European Power Electronics and Applications Conf. EPE, Brussels, Belgium, 1985, pp. 1.147–1.152
- 10 Ferraris, P., and Lazzari, M.: 'Phase numbers and their related effects on the characteristics of inverter fed induction motor drives'. Proc. IEEE Industry Applications Society Annual Meeting IAS, Mexico City, Mexico, 1983, pp. 494–502
- 11 Williamson, S., and Smith, A.C.: 'Pulsating torque and losses in multiphase induction machines', *IEEE Trans. Ind. Appl.*, 2003, **39**, (4), pp. 986–993
- 12 Smith, A.C., Williamson, S., and Hodge, C.G.: 'High torque dense naval propulsion motors'. Proc. IEEE International Electric Machines and Drives Conf. IEMDC, Madison, WI, 2003, pp. 1421–1427
- 13 Abbas, M.A., Christen, R., and Jahns, T.M.: 'Six-phase voltage source inverter driven induction motor', *IEEE Trans. Ind. Appl.*, 1984, **20**, (5), pp. 1251–1259
- 14 Pavithran, K.N., Parimelalagan, R., and Krishnamurthy, M.R.: 'Studies on inverter-fed five-phase induction motor drive', *IEEE Trans. Power Electron.*, 1988, **3**, (2), pp. 224–235
- 15 Andrese, E., and Bieniek, K.: '6-phase induction motors for current-source inverter drives'. Proc. IEEE Industry Applications Society Annual Meeting IAS, Philadelphia, PA, 1981, pp. 607–618
- 16 Gopakumar, K., Sathiakumar, S., Biswas, S.K., and Vithayathil, J.: 'Modified current source inverter fed induction motor drive with reduced torque pulsations', *IEE Proc., Pt. B*, 1984, **131**, (4), pp. 159–164
- 17 Dente, J., and Labrique, F.: 'Induction motor-current source inverter systems with phase number greater than 3'. Proc. European Power Electronics and Applications Conf. EPE, Brussels, Belgium, 1985, pp. 3.143–3.147
- 18 White, D.C., and Woodson, H.H.: 'Electromechanical energy conversion' (John Wiley and Sons, New York, NY, 1959)
- 19 Golubev, A.N., and Zykov, V.V.: 'Asynchronous motor with multiphase stator and rotor windings', *Russ. Electr. Eng.*, 2003, **74**, (7), pp. 43–51
- 20 Pereira, L.A., Scharlau, C.C., Pereira, L.F.A., and Haffner, J.F.: 'Model of a five-phase induction machine allowing for harmonics in the air-gap field, Part I: Parameter determination and general equations'. Proc. IEEE Industrial Electronics Society Annual Meeting IECON. Busan, Korea, 2004, CD-ROM paper WC3-6
- 21 Pereira, L.A., Scharlau, C.C., Pereira, L.F.A., and Haffner, J.F.: 'Model of a five-phase induction machine allowing for harmonics in the air-gap field, Part II: Transformation of co-ordinates and d-q models'. Proc. IEEE Industrial Electronics Society Annual Meeting IECON. Busan, Korea, 2004, CD-ROM paper TD3-4
- 22 Kestelyn, X., Semail, E., and Hautier, J.P.: 'Vectorial multi-machine modeling for a five-phase machine'. Proc. Int. Conf. on Electrical Machines ICEM. Bruges, Belgium, 2002, CD-ROM paper 394
- 23 Mokhtari, N., Benkhoris, M.F., Merabtene, M., and Doeuff, R. Le: 'Vectorial modeling approach of multi-star machine supplied by voltage source inverters'. Proc. Int. Conf. on Electrical Machines ICEM. Krakow, Poland, 2004, CD-ROM paper no. 449
- 24 Semail, E., Bouscayrol, A., and Hautier, J.P.: 'Vectorial formalism for analysis and design of polyphase synchronous machines', *Eur. Phys. J.—Appl. Phys.*, 2003, **22**, (3), pp. 207–220
- 25 Terrien, F., Siala, S., and Noy, P.: 'Multiphase induction motor sensorless control for electric ship propulsion'. Proc. IEE Power Electronics, Machines and Drives Conf. PEMD, Edinburgh, Scotland, 2004, pp. 556–561
- 26 McCoy, T., and Bentamane, M.: 'The all electric warship: an overview of the U.S. Navy's integrated power system development programme'. Proc. Int. Conf. on Electric Ship ELECSHIP, Istanbul, Turkey, 1998, pp. 1–4

- 27 Benatmane, M., and McCoy, T.: 'Development of a 19 MW PWM converter for U.S. Navy surface ships'. Proc. Int. Conf. on Electric Ship ELECSHIP, Istanbul, Turkey, 1998, pp. 109–113
- 28 Ferreira, C.L., and Bucknall, R.W.G.: 'Modelling and real-time simulation of an advanced marine full-electrical propulsion system'. Proc. IEE Power Electronics, Machines and Drives Conf. PEMD, Edinburgh, Scotland, 2004, pp. 574–579
- 29 Corzine, K.A., Sudhoff, S.D., Lewis, E.A., Schmucker, D.H., Youngs, R.A., and Hegner, H.J.: 'Use of multi-level converters in ship propulsion drives'. Proc. All Electric Ship Conf., London, England, 1998, pp. 155–163
- 30 Hadiouche, D., Razik, H., and Rezzoug, A.: 'Modelling of a double-star induction motor with an arbitrary shift angle between its three phase windings'. Proc. 9th Int. Conf. on Power Electronics and Motion Control PEMC, Kosice, Slovakia, 2000, pp. 5.125–5.130
- 31 Zhao, Y., and Lipo, T.A.: 'Space vector PWM control of dual three-phase induction machine using vector space decomposition', *IEEE Trans. Ind. Appl.*, 1995, **31**, (5), pp. 1100–1109
- 32 Duran, M.J., Levi, E., and Jones, M.: 'Independent vector control of asymmetrical nine-phase machines by means of series connection'. Proc. IEEE Int. Electric Machines and Drives Conf. IEMDC, San Antonio, TX, 2005, pp. 167–173
- 33 Nelson, R.H., and Krause, P.C.: 'Induction machine analysis for arbitrary displacement between multiple winding sets', *IEEE Trans. Power Appar. Syst.*, 1974, **93**, (3), pp. 841–848
- 34 Lipo, T.A.: 'A d-q model for six phase induction machines'. Proc. Int. Conf. on Electrical Machines ICEM, Athens, Greece, 1980, pp. 860–867
- 35 Camillis, L., de Matuonto, M., Monti, A., and Vignati, A.: 'Optimizing current control performance in double winding asynchronous motors in large power inverter drives', *IEEE Trans. Power Electron.*, 2001, **16**, (5), pp. 676–685
- 36 Bojoi, R., Lazzari, M., Profumo, F., and Tenconi, A.: 'Digital field oriented control for dual three-phase induction motor drives'. Proc. IEEE Industry Applications Society Annual Meeting IAS, Pittsburgh, Pennsylvania, 2002, CD-ROM paper 22P1
- 37 Bojoi, R., Profumo, F., and Tenconi, A.: 'Digital synchronous frame current regulation for dual three-phase induction motor drives'. Proc. IEEE Power Electronics Specialists Conf. PESC, Acapulco, Mexico, 2003, pp. 1475–1480
- 38 Toliyat, H.A., Waikar, S.P., and Lipo, T.A.: 'Analysis and simulation of five-phase synchronous reluctance machines including third harmonic of airgap mmf', *IEEE Trans. Ind. Appl.*, 1998, **34**, (2), pp. 332–339
- 39 Coates, C.E., Platt, D., and Gosbell, V.J.: 'Performance evaluation of a nine-phase synchronous reluctance drive'. Proc. IEEE Industry Applications Society Annual Meeting IAS, Chicago, IL, 2001, pp. 2041–2047
- 40 Parsa, L., and Toliyat, H.A.: 'Five-phase permanent-magnet motor drives', *IEEE Trans. Ind. Appl.*, 2005, **41**, (1), pp. 30–37
- 41 Lyra, R.O.C., and Lipo, T.A.: 'Six-phase induction machine with third harmonic current injection'. Proc. Electrimacs, Montreal, Canada, 2002, CD-ROM paper 304
- 42 Lyra, R.O.C., and Lipo, T.A.: 'Torque density improvement in a six-phase induction motor with third harmonic current injection', *IEEE Trans. Ind. Appl.*, 2002, **38**, (5), pp. 1351–1360
- 43 Bendixen, F.B., Blaabjerg, F., Rasmussen, P.O., Vadstrup, P., and Krabbe, K.: 'Controlling the dc-link midpoint potential in a six-phase motor-drive'. Proc. IEEE Power Electronics Specialists Conf. PESC, Aachen, Germany, 2004, pp. 2128–2132
- 44 Stumberger, B., Stumberger, G., Hamler, A., Trlep, M., Jesenik, M., and Gorican, V.: 'Increasing of output power capability in a six-phase flux-weakened permanent magnet synchronous motor with a third harmonic current injection', *IEEE Trans. Magn.*, 2003, **39**, (5), pp. 3343–3345
- 45 Xu, H., Toliyat, H.A., and Petersen, L.J.: 'Rotor field oriented control of five-phase induction motor with the combined fundamental and third harmonic currents'. Proc. IEEE Applied Power Electronics Conf. APEC, Anaheim, CA, 2001, pp. 392–398
- 46 Xu, H., Toliyat, H.A., and Petersen, L.J.: 'Five-phase induction motor drives with DSP-based control system', *IEEE Trans. Power Electron.*, 2002, **17**, (4), pp. 524–533
- 47 Locment, F., Semail, E., and Kestelyn, X.: 'Optimum use of DC bus by fitting the back-electromotive force of a 7-phase permanent magnet synchronous machine'. Proc. European Power Electronics and Applications Conf. EPE, Dresden, Germany, 2005, CD-ROM paper 484
- 48 Singh, G.K., Nam, K., and Lim, S.K.: 'A simple indirect field-oriented control scheme for multiphase induction machine', *IEEE Trans. Ind. Electron.*, 2005, **52**, (4), pp. 1177–1184
- 49 Bojoi, R., Farina, F., Lazzari, M., Profumo, F., and Tenconi, A.: 'Analysis of the asymmetrical operation of dual three-phase induction machines'. Proc. IEEE Int. Electric Machines and Drives Conf. IEMDC, Madison, WI, 2003, pp. 429–435
- 50 Bojoi, R., Levi, E., Farina, F., Tenconi, A., and Profumo, F.: 'Dual three-phase induction motor drive with digital current control in the stationary reference frame', *IEE Proc. Electr. Power Appl.*, 2006, **153**, (1), pp. 129–139
- 51 Hou, L., Su, Y., and Chen, L.: 'DSP-based indirect rotor flux oriented control for multiphase induction machines'. Proc. IEEE Int. Electric Machines and Drives Conf. IEMDC, Madison, WI, 2003, pp. 976–980
- 52 Sudhoff, S.D., Alt, J.T., Hegner, N.J., and Robey, H.N. Jr.: 'Control of a 15-phase induction motor drive system'. Proc. of the 1997 Naval Symp. on Electric Machines, Newport, RI, 1997, pp. 69–75
- 53 Iqbal, A., Vukosavic, S., Levi, E., Jones, M., and Toliyat, H.A.: 'Dynamics of a series-connected two-motor five-phase drive system with a single-inverter supply'. Proc. IEEE Industry Applications Society Annual Meeting IAS, Hong Kong, 2005, pp. 1081–1088
- 54 Singh, G.K., Pant, Y., and Singh, Y.P.: 'Voltage source inverter driven multi-phase induction machine', *Comput. Electr. Eng.*, 2003, **29**, (8), pp. 813–834
- 55 Razik, H., Rezzoug, A., and Hadiouche, D.: 'Modelling and analysis of dual-star induction motors', *IEEJ Trans. Ind. Appl.*, 2005, **125**, (12), pp. 1093–1104
- 56 Vukosavic, S.N., Jones, M., Levi, E., and Varga, J.: 'Rotor flux oriented control of a symmetrical six-phase induction machine', *Electr. Power Syst. Res.*, 2005, **75**, (2–3), pp. 142–152
- 57 Bojoi, R., Farina, F., Griva, G., Profumo, F., and Tenconi, A.: 'Direct torque control for dual three-phase induction motor drives', *IEEE Trans. Ind. Appl.*, 2005, **41**, (6), pp. 1627–1636
- 58 Kestelyn, X., Semail, E., and Loriot, D.: 'Direct torque control of a multi-phase permanent magnet synchronous motor drive: application to a five-phase one'. Proc. IEEE Int. Electric Machines and Drives Conf. IEMDC, San Antonio, TX, 2005, pp. 137–143
- 59 Toliyat, H.A., and Xu, H.: 'DSP-based direct torque control (DTC) for five-phase induction machines'. Proc. Int. Power Electronics Conf. IPEC, Tokyo, Japan, 2000, pp. 1195–1200
- 60 Toliyat, H.A., and Xu, H.: 'A novel direct torque control (DTC) method for five-phase induction machines'. Proc. IEEE Applied Power Electronics Conf. APEC, New Orleans, LA, 2000, pp. 162–168
- 61 Hatua, K., and Ranganathan, V.T.: 'Direct torque control schemes for split-phase induction machine', *IEEE Trans. Ind. Appl.*, 2005, **41**, (5), pp. 1243–1254
- 62 Lu, S., and Corzine, K.: 'Multilevel multi-phase propulsion drives'. Proc. IEEE Electric Ship Technologies Symposium ESTS, Philadelphia, PA, 2005, pp. 363–370
- 63 Kelly, J.W., Strangas, E.G., and Miller, J.M.: 'Multi-phase inverter analysis'. Proc. IEEE Int. Electric Machines and Drives Conf. IEMDC, Cambridge, MA, 2001, pp. 147–155
- 64 Ojo, O., and Dong, G.: 'Generalized discontinuous carrier-based PWM modulation scheme for multi-phase converter-machine systems'. Proc. IEEE Industry Applications Society Annual Meeting IAS, Hong Kong, 2005, CD-ROM paper 38P3
- 65 Iqbal, A., Levi, E., Jones, M., and Vukosavic, S.N.: 'Generalised sinusoidal PWM with harmonic injection for multi-phase VSIs'. Proc. IEEE Power Electronics Specialists Conf. PESC, Jeju, Korea, 2006, pp. 2871–2877
- 66 Siala, S., Guette, E., and Pouliquen, J.L.: 'Multi-inverter control: a new generation drives for cruise ship electric propulsion'. Proc. European Power Electronics and Applications Conf. EPE, Toulouse, France, 2003, CD-ROM paper 919
- 67 Bojoi, R., Tenconi, A., Profumo, F., Griva, G., and Martinello, D.: 'Complete analysis and comparative study of digital modulation techniques for dual three-phase AC motor drives'. Proc. IEEE Power Electronics Specialists Conf. PESC, Cairns, Australia, 2002, CD-ROM paper 10159
- 68 Takami, H., and Matsumoto, H.: 'Optimal pulse patterns of a nine-phase voltage source PWM inverter for use with a triple three-phase wound AC motor', *Electr. Eng. Jpn*, 1993, **113**, (6), pp. 102–113
- 69 Iqbal, A., Levi, E., Jones, M., and Vukosavic, S.N.: 'A PWM scheme for a five-phase VSI supplying a five-phase two-motor drive'. Proc. IEEE Industrial Electronics Society Annual Meeting IECON, Paris, France, 2006, pp. 2575–2580
- 70 Toliyat, H.A., Rahimian, M.M., and Lipo, T.A.: 'Analysis and modeling of five phase converters for adjustable speed drive applications'. Proc. European Power Electronics and Applications Conf. EPE, Brighton, UK, 1993, pp. 194–199
- 71 Toliyat, H.A., Shi, R., and Xu, H.: 'A DSP-based vector control of five-phase synchronous reluctance motor'. Proc. IEEE Industry

- Applications Society Annual Meeting IAS Rome, Italy, 2000, CD-ROM Paper No. 40_05
- 72 Iqbal, A., and Levi, E.: 'Space vector PWM techniques for sinusoidal output voltage generation with a five-phase voltage source inverter', *Electr. Power Compon. Syst.*, 2006, **34**, (2), pp. 119–140
 - 73 Gopakumar, K., Ranganathan, V.T., and Bhat, S.R.: 'Split-phase induction motor operation from PWM voltage source inverter', *IEEE Trans. Ind. Appl.*, 1993, **29**, (5), pp. 927–932
 - 74 Monti, A., Morando, A.P., Resta, L., and Riva, M.: 'Comparing two-level GTO-inverter feeding a double star asynchronous motor with a three level GTO-inverter feeding a single star asynchronous motor'. Proc. European Power Electronics and Applications Conf. EPE, Seville, Spain, 1995, p. 2.419–2.425
 - 75 Kelly, J.W., Strangas, E.G., and Miller, J.M.: 'Multiphase space vector pulse width modulation', *IEEE Trans. Energy Convers.*, 2003, **18**, (2), pp. 259–264
 - 76 Hadiouche, D., Baghli, L., and Rezzoug, A.: 'Space vector PWM techniques for dual three-phase AC machine: Analysis, performance evaluation and DSP implementation'. Proc. IEEE Industry Application Society Annual Meeting IAS, Salt Lake City, Utah, 2003, pp. 649–655
 - 77 Ryu, H.M., Kim, J.H., and Sul, S.K.: 'Analysis of multiphase space vector pulse-width modulation based on multiple d-q spaces concept', *IEEE Trans. Power Electron.*, 2005, **20**, (6), pp. 1364–1371
 - 78 Casadei, D., Serra, G., Tani, A., and Zarri, L.: 'Multi-phase inverter modulation strategies based on duty-cycle space vector approach'. Proc. Ship Propulsion and Railway Traction Systems Conf. SPRTS, Bologna, Italy, 2005, pp. 222–229
 - 79 Gopakumar, K., Ranganathan, V.T., and Bhat, S.R.: 'An efficient PWM technique for split phase induction motor operation using dual voltage source inverter'. Proc. IEEE Industry Applications Society Annual Meeting IAS, Toronto, ON, 1993, pp. 582–587
 - 80 Correa, M.B.R., Jacobina, C.B., da Silva, C.R., Lima, A.M.N., and da Silva, E.R.C.: 'Vector and scalar modulation for six-phase voltage source inverters'. Proc. IEEE Power Electronics Specialists Conf. PESC, Acapulco, Mexico, 2003, pp. 562–567
 - 81 Bakhshai, A.T., Joos, R., and Jin, H.: 'Space vector PWM control of a split-phase induction machine using the vector classification technique'. Proc. IEEE Applied Power Electronics Conf. APEC, Atlanta, GA, 1997, pp. 802–808
 - 82 Silva, P.S.N., De Fletcher, J.E., and Williams, B.W.: 'Development of space vector modulation strategies for five-phase voltage source inverters'. Proc. IEE Power Electronics, Machines and Drives Conf. PEMD, Edinburgh, UK, 2004, pp. 650–655
 - 83 Iqbal, A., and Levi, E.: 'Space vector modulation schemes for a five-phase voltage source inverter'. Proc. European Power Electronics and Applications Conf. EPE, Dresden, Germany, 2005, CD-ROM paper 0006
 - 84 Kestelyn, X., Semail, E., and Hautier, J.P.: 'Multi-phase system supplied by SVM VSI: A new fast algorithm to compute duty cycles', *EPE J.*, 2004, **14**, (3), pp. 25–31
 - 85 Delarue, P., Bouscayrol, A., and Semail, E.: 'Generic control method of multilevel voltage-source converters for fast practical implementation', *IEEE Trans. Power Electron.*, 2003, **18**, (2), pp. 517–526
 - 86 Oriti, G., Julian, A.L., and Lipo, T.A.: 'An inverter/motor drive with common mode voltage elimination'. Proc. IEEE Industry Applications Society Annual Meeting IAS, New Orleans, LA, 1997, pp. 587–592
 - 87 Correa, M.B.R., Jacobina, C.B., da Silva, C.R., Lima, A.M.N., and da Silva, E.R.C.: 'Six-phase AC drive system with reduced common-mode voltage'. Proc. IEEE Int. Electric Machines and Drives Conf. IEMDC, Madison, WI, 2003, pp. 1852–1858
 - 88 Jouanne, A. von, and Zhang, H.: 'A dual-bridge inverter approach to eliminating common-mode voltages and bearing and leakage currents', *IEEE Trans. Power Electron.*, 1999, **14**, (1), pp. 43–48
 - 89 Kianinezhad, R., Nahid, B., Betin, F., and Capolino, G.A.: 'Multi-vector SVM: A new approach to space vector modulation for six-phase induction machines'. Proc. IEEE Industrial Electronics Society Annual Meeting IECON, Raleigh, NC, 2005, pp. 1359–1364
 - 90 Gataric, S.: 'A polyphase Cartesian vector approach to control of polyphase AC machines'. Proc. IEEE Industry Applications Society Annual Meeting, Rome, Italy, 2000, CD-ROM paper 38_02
 - 91 Semail, E., and Rombaut, C.: 'New method to calculate the conduction durations of the switches in a n-leg 2-level voltage source inverter'. Proc. European Power Electronics and Applications Conf. EPE, Graz, Austria, 2003, CD-ROM paper no. PP0621
 - 92 Steiner, M., Deplazes, R., and Stemmler, H.: 'A new transformerless topology for AC-fed traction vehicles using multi-star induction motors', *EPE J.*, 2000, **10**, (3–4), pp. 45–53
 - 93 Oudjebour, Z., Berkouk, E.M., Sami, N., Belgasmi, S., Arezki, S., and Messaif, I.: 'Indirect space vector control of a double star induction machine fed by two five-levels NPC VSI'. Proc. Int. Conf. on Electrical Machines ICEM, Krakow, Poland, 2004, CD-ROM paper no. 155
 - 94 Shi, R., Toliyat, H.A., and El-Antalby, A.: 'Field oriented control of five-phase synchronous reluctance motor drive with flexible 3rd harmonic current injection for high specific torque'. Proc. IEEE Industry Applications Society Annual Meeting IAS, Chicago, IL, 2001, pp. 2097–2103
 - 95 Toliyat, H.A., Xu, L.Y., and Lipo, T.A.: 'A five-phase reluctance motor with high specific torque', *IEEE Trans. Ind. Appl.*, 1992, **28**, (3), pp. 659–667
 - 96 Toliyat, H.A., Lipo, T.A., and Coleman, J.: 'Analysis of a concentrated winding induction machine for adjustable speed drive applications, Part 1—Motor analysis', *IEEE Trans. Energy Convers.*, 1991, **6**, (4), pp. 679–683
 - 97 Ryu, H.M., Kim, J.W., and Sul, S.K.: 'Synchronous frame current control of multi-phase synchronous motor, Part I: Modeling and current control based on multiple d-q spaces concept under balanced condition'. Proc. IEEE Industry Applications Society Annual Meeting IAS, Seattle, WA, 2004, CD-ROM paper no. 04IAS02P3
 - 98 Mantero, S., Paola, E. De, and Marina, G.: 'An optimised control strategy for double star motors configuration in redundancy operation mode'. Proc. European Power Electronics and Applications Conf. EPE, Lausanne, Switzerland, 1999, CD-ROM paper no. 013
 - 99 Mantero, S., Monti, A., and Spreafico, S.: 'DC-bus voltage control for double star asynchronous fed drive under fault conditions'. Proc. IEEE Power Electronics Specialists Conf. PESC, Galway, Ireland, 2000, pp. 533–538
 - 100 Bojoi, R., Farina, F., Profumo, F., and Tenconi, A.: 'Dual-three phase induction machine drives control – A survey', *IEEJ Trans. Ind. Appl.*, 2006, **126**, (4), pp. 420–429
 - 101 Bojoi, R., Tenconi, A., Griva, G., and Profumo, F.: 'Vector control of dual three-phase induction motor drives using two current sensors'. Proc. IEEE Industry Applications Society Annual Meeting IAS, Hong Kong, 2005, pp. 1805–1812
 - 102 Farina, F., Bojoi, R., Tenconi, A., and Profumo, F.: 'Direct torque control with full order stator flux observer for dual-three phase induction motor drives', *IEEJ Trans. Ind. Appl.*, 2006, **126**, (4), pp. 412–419
 - 103 Mohapatra, K.K., Kanchan, R.S., Baiju, M.R., Tekwani, P.N., and Gopakumar, K.: 'Independent field-oriented control of two split-phase induction motors from a single six-phase inverter', *IEEE Trans. Ind. Electron.*, 2005, **52**, (5), pp. 1372–1382
 - 104 Bojoi, R., Tenconi, A., Profumo, F., and Farina, F.: 'Dual-source fed multi-phase induction motor drive for fuel cell vehicles: Topology and control'. Proc. IEEE Power Electronics Specialists Conf. PESC, Recife, Brazil, 2005, pp. 2676–2683
 - 105 Jiang, S.Z., Chau, K.T., and Chan, C.C.: 'Spectral analysis of a new six-phase pole-changing induction motor drive for electric vehicles', *IEEE Trans. Ind. Electron.*, 2003, **50**, (1), pp. 123–131
 - 106 Jiang, S.Z., Chau, K.T., and Chan, C.C.: 'Harmonic reduction in DC-link current of a dual-inverter pole-changing induction motor drive for electric vehicles', *Electr. Power Compon. Syst.*, 2003, **31**, (11), pp. 1063–1081
 - 107 Miller, J.M., Stefanovic, V., Ostovic, V., and Kelly, J.: 'Design considerations for an automotive integrated starter-generator with pole-phase modulation'. Proc. IEEE Industry Applications Society Annual Meeting IAS, Chicago, Illinois, 2001, CD-ROM paper 56_06
 - 108 Mohapatra, K.K., Gopakumar, K., Somasekar, V.T., and Umanand, L.: 'A novel modulation scheme for a six-phase induction motor with open-end windings'. Proc. IEEE Industrial Electronics Society Annual Meeting IECON, Seville, Spain, 2002, pp. 810–815
 - 109 Miranda, R.S., Jacobina, C.B., Correa, M.B.R., and Lima, A.M.N.: 'Reduced switch count dual-winding AC motor drive systems'. Proc. IEEE Power Electronics Specialists Conf. PESC, Recife, Brazil, 2005, pp. 726–732
 - 110 Jacobina, C.B., Correa, M.B.R., da Silva, C.R., da Oliveira, T.M., and Silva, E.R.C.: 'Reversible six-phase AC motor drive systems with reduced switch count'. Proc. IEEE Industry Applications Society Annual Meeting IAS, Seattle, WA, 2004, CD-ROM paper no. 04IAS62P7
 - 111 Jacobina, C.B., Miranda, R.S., and Lima, A.M.N.: 'Reconfigurable fault tolerant dual-winding AC motor drive system'. Proc. IEEE Power Electronics Specialists Conf. PESC, Recife, Brazil, 2005, pp. 1574–1579
 - 112 Fu, J.R., and Lipo, T.A.: 'Disturbance-free operation of a multiphase current-regulated motor drive with an opened phase', *IEEE Trans. Ind. Appl.*, 1994, **30**, (5), pp. 1267–1274

- 113 Jahns, T.M.: 'Improved reliability in solid-state AC drives by means of multiple independent phase-drive units', *IEEE Trans. Ind. Appl.*, 1980, **IA-16**, (3), pp. 321–331
- 114 Merabtene, M., Benkhoris, M.F., and Doeuff, R.Le: 'A unified model to control the DSSM PWM inverter set under balanced and unbalanced functioning'. Proc. European Power Electronics and Applications Conf. EPE. Toulouse, France, 2003, CD-ROM paper no. 417
- 115 Singh, G.K., and Pant, V.: 'Analysis of multiphase induction machine under fault condition in a phase-redundant AC drive system', *Electr. Mach. Power Syst.*, 2000, **28**, (6), pp. 577–590
- 116 Golubev, A.N., and Ignatenko, V.: 'Anomalous operation of multiphase asynchronous electric drive', *Russ. Electr. Eng.*, 2001, **72**, (10), pp. 22–28
- 117 Gerada, C., Bradley, K.J., Sumner, M., Wheeler, P., Pickering, S., Clare, J., Whitley, C., and Towers, G.: 'The implications of winding faults in induction motor drives'. Proc. IEEE Industry Applications Society Annual Meeting IAS, Seattle, WA, 2004, pp. 2506–2513
- 118 Apsley, J.M., and Williamson, S.: 'Analysis of multi-phase propulsion machines with winding faults'. Proc. IEEE Int. Electric Machines and Drives Conf. IEMDC, San Antonio, TX, 2005, pp. 249–255
- 119 Williamson, S., and Smith, S.: 'Fault tolerance in multiphase propulsion motors', *J. Mar. Eng. Technol.*, 2004, **A4**, pp. 3–7
- 120 Zhao, Y., and Lipo, T.A.: 'Modeling and control of a multi-phase induction machine with structural unbalance. Part I: Machine modeling and multi-dimensional current regulation', *IEEE Trans. Energy Convers.*, 1996, **11**, (3), pp. 570–577
- 121 Zhao, Y., and Lipo, T.A.: 'Modeling and control of a multi-phase induction machine with structural unbalance. Part II: Field-oriented control and experimental verification', *IEEE Trans. Energy Convers.*, 1996, **11**, (3), pp. 578–584
- 122 Jacobina, C.B., Miranda, R.S., Correa, M.B.R., and Lima, A.M.N.: 'Disturbance-free operation of a six-phase AC motor drive system'. Proc. IEEE Power Electronics Specialists Conf. PESC, Aachen, Germany, 2004, pp. 925–931
- 123 Xu, H., Toliyat, H.A., and Petersen, L.J.: 'Resilient current control of five-phase induction motor under asymmetrical fault conditions'. Proc. IEEE Applied Power Electronics Conf. APEC, Dallas, Texas, 2002, pp. 64–71
- 124 Toliyat, H.A.: 'Analysis and simulation of five-phase variable-speed induction motor drives under asymmetrical connections', *IEEE Trans. Power Electron.*, 1998, **13**, (4), pp. 748–756
- 125 Zheng, L., Fletcher, J.E., and Williams, B.W.: 'Current optimisation for a multi-phase machine under an open-circuit phase fault condition'. Proc. IEE Int. Conf. on Power Electronics, Machines and Drives PEMD, Dublin, Ireland, 2006, pp. 414–419
- 126 de Silva, P.S.N., Fletcher, J.E., and Williams, B.W.: 'Analysis of concentrated winding multi-phase machines under phase failure using decoupled vector space theory'. Proc. IEE Int. Conf. on Power Electronics, Machines and Drives PEMD, Dublin, Ireland, 2006, pp. 420–424
- 127 Jacobina, C.B., Freitas, I.S., Oliveira, T.M., Silva, E.R.C. da, and Lima, A.M.N.: 'Fault tolerant control of five-phase AC motor drive'. Proc. IEEE Power Electronics Specialists Conf. PESC, Aachen, Germany, 2004, pp. 3486–3492
- 128 Ryu, H.M., Kim, J.W., and Sul, S.K.: 'Synchronous frame current control of multi-phase synchronous motor, Part II: Asymmetrical fault condition due to open phases'. Proc. IEEE Industry Applications Society Annual Meeting IAS. Seattle, WA, 2004, CD-ROM paper no. 04IAS08P3
- 129 Parsa, L., and Toliyat, H.A.: 'Fault-tolerant five-phase permanent magnet motor drives'. Proc. IEEE Industry Applications Society Annual Meeting IAS. Seattle, WA, 2004, CD-ROM paper no. 04IAS28P4
- 130 Figureoa, J., Cros, J., and Viarouge, P.: 'Polyphase PM brushless DC motor for high reliability application'. Proc. European Power Electronics and Applications Conf. EPE, Toulouse, France, 2003, CD-ROM paper 1079
- 131 Mecrow, B.C., Jack, A.G., Atkinson, D.J., Green, S.R., Atkinson, G.J., King, A., and Green, B.: 'Design and testing of a four-phase fault-tolerant permanent magnet machine for an engine fuel pump', *IEEE Trans. Energy Convers.*, 2004, **19**, (4), pp. 671–678
- 132 Wang, J., Atallah, K., and Howe, D.: 'Optimal torque control of fault-tolerant permanent magnet brushless machines', *IEEE Trans. Magn.*, 2003, **39**, (5), pp. 2962–2964
- 133 Mecrow, B.C., Jack, A.G., Haylock, J.A., and Coles, J.: 'Fault tolerant permanent magnet machine drives', *IEE Proc. – Electr. Power Appl.*, 1996, **143**, (6), pp. 437–442
- 134 Atkinson, G.J., Mecrow, B.C., Jack, A.G., Atkinson, D.J., Sangha, P., and Benarous, M.: 'The design of fault tolerant machines for aerospace applications'. Proc. IEEE Int. Electric Machines and Drives Conf. IEMDC, San Antonio, TX, 2005, pp. 1863–1869
- 135 Abolhassani, M.T.: 'A novel multiphase fault tolerant high torque density permanent magnet motor drive for traction applications'. Proc. IEEE Int. Electrical Machines and Drives Conf. IEMDC, San Antonio, TX, 2005, pp. 728–734
- 136 Mitcham, A.J., Antonopoulos, G., and Cullen, J.J.A.: 'Favourable slot and pole number combinations for fault-tolerant PM machines', *IEE Proc.—Electr. Power Appl.*, 2004, **151**, (5), pp. 520–525
- 137 Levi, E., Jones, M., and Vukosavic, S.N.: 'Even-phase multi-motor vector controlled drive with single inverter supply and series connection of stator windings', *IEE Proc.—Electr. Power Appl.*, 2003, **150**, (5), pp. 580–590
- 138 Levi, E., Jones, M., Vukosavic, S.N., and Toliyat, H.A.: 'A novel concept of a multiphase, multi-motor vector controlled drive system supplied from a single voltage source inverter', *IEEE Trans. Power Electron.*, 2004, **19**, (2), pp. 320–335
- 139 Mohapatra, K.K., Baiju, M.R., and Gopakumar, K.: 'Independent speed control of two six-phase induction motors using a single six-phase inverter', *EPE J.*, 2004, **14**, (3), pp. 49–61
- 140 Levi, E., Vukosavic, S.N., and Jones, M.: 'Vector control schemes for series-connected six-phase two-motor drive systems', *IEE Proc. – Electr. Power Appl.*, 2005, **152**, (2), pp. 226–238
- 141 Jones, M., Vukosavic, S.N., Levi, E., and Iqbal, A.: 'A six-phase series-connected two-motor drive with decoupled dynamic control', *IEEE Trans. Ind. Appl.*, 2005, **41**, (4), pp. 1056–1066
- 142 Jones, M., Levi, E., and Iqbal, A.: 'Vector control of a five-phase series-connected two-motor drive using synchronous current controllers', *Electr. Power Compon. Syst.*, 2005, **33**, (4), pp. 411–430
- 143 Levi, E., Jones, M., Vukosavic, S.N., and Toliyat, H.A.: 'A five-phase two-machine vector controlled induction motor drive supplied from a single inverter', *EPE J.*, 2004, **14**, (3), pp. 38–48
- 144 Jones, M., Levi, E., and Vukosavic, S.N.: 'A parallel-connected vector-controlled five-phase two-motor drive'. Proc. Int. Conf. on Electrical Machines ICEM. Chania, Greece, 2006, CD-ROM paper no. PMA2-19
- 145 Jones, M., Levi, E., and Vukosavic, S.N.: 'Independent control of two five-phase induction machines connected in parallel to a single inverter supply'. Proc. IEEE Industrial Electronics Society Annual Meeting IECON, Paris, France, 2006, pp. 1257–1262
- 146 Levi, E., Jones, M., Vukosavic, S.N., and Toliyat, H.A.: 'Steady state modelling of series-connected five-phase and six-phase two-motor drives'. Proc. IEEE Industry Applications Society Annual Meeting IAS. Tampa, FL, 2006, CD-ROM paper no. IAS11p1
- 147 Edelson, J.S., Cox, I.W., and Magdych, J.S.: 'The Chorus Meshcon solution for starter-generator'. Proc. IEEE Int. Electric Machines and Drives Conf. IEMDC, San Antonio, TX, 2005, pp. 1720–1724