

NOTE

Oxygen microgradients in the rhizosphere of the mangrove *Avicennia marina*

Frede Østergaard Andersen, Erik Kristensen

Institute of Biology, Odense University, DK-5230 Odense M, Denmark

ABSTRACT: Oxygen concentration was measured in aerial roots (pneumatophores), horizontal cable roots and surrounding sediment of the tree *Avicennia marina* (Forsk.) Vierh. in a mangrove swamp at Ao Nam Bor, on the southeast coast of Phuket Island, Thailand. The O₂ measurements were made in the field with a polarographic oxygen minielectrode. The O₂ concentration inside pneumatophores was 63 to 88 % of air saturation, whereas the cable roots showed a lower concentration (62 to 73 %) indicating an O₂ gradient from the emerging parts to the subsurface roots. The O₂ concentration in the roots was highest in the outer part of the aerenchyma. The oxic zone of the sediment around roots was thin (ca 0.5 mm) which may indicate that very little O₂ is released from the roots. Recording around a fiddler crab (*Uca* sp.) burrow revealed, for comparison, that the oxic layer of the burrow wall was ca 1 mm thick. The penetration depth for O₂ at the surface of this tropical mangrove sediment (1.5 to 3 mm) was similar to that measured in temperate coastal sediments.

Sediments in mangrove swamps are in general O₂-depleted, with only a thin oxic surface layer (Kristensen et al. unpubl.). Mangroves therefore possess special adaptations for supplying O₂ to the respiring root system. Hence many mangroves have negatively geotropic roots that emerge above the sediment surface, and these contain well-developed aerenchyma tissue. Pneumatophores (aerial roots), which are found for example in *Avicennia* and *Sonneratia*, have long been considered as organs responsible for gaseous exchange between the atmosphere and the internal tissues of mangroves (Goebel 1886). Other genera as *Bruguiera* and *Lumnitzera* have emerging kneelike bends on their lateral roots. In *Rhizophora* spp. the prop roots are responsible for gaseous exchange (Chapman 1976).

Chapman (1976) gives a review of the relatively few experimental studies that have been made on the function of the pneumatophores. These studies were made more than 30 yr ago, often with manometric techniques and on cut and isolated root parts. Scholander et al. (1955) found that the O₂ concentration in *Rhizophora*

prop roots approached that of the atmosphere (14 to 19 %) whereas the CO₂ concentration was higher (4 to 6 %). The same authors also studied mechanisms for gas transport in the root systems of *Avicennia*.

The purpose of the present study was to measure O₂ concentrations around and inside intact pneumatophores and cable roots of *Avicennia marina* in the field. If significant amounts of O₂ are released from the gas-transporting roots, an oxic zone outside the roots would be expected. For comparison we measured O₂ profiles around an air-filled burrow of a fiddler crab (*Uca* sp.).

Materials and methods. The investigation was carried out in January 1987 in the Ao Nam Bor mangrove on the southeast coast of Phuket Island, southwest Thailand (Frith et al. 1976, Christensen 1978). This mangrove forest is ca 200 m wide at the study site and is bordered by a ca 500 m wide tidal flat without vegetation. The measurements were made around an isolated *Avicennia marina* (Forsk.) Vierh. tree at the seaward edge of the mangrove forest and around a fiddler crab (*Uca* sp.) burrow situated 5 m from the tree on the tidal flat. The sediment and pneumatophores were covered by 60 to 70 cm water at high tide. The tidal range in the area was ca 2 m. Salinity of the seawater was 35 ‰ and water temperature was 28 °C. However, the temperature of the sediment surface may rise to 35 to 38 °C at low tide when the sediment is exposed to direct sun.

Oxygen concentration was measured with a polarographic needle minielectrode (2.5 cm long, 0.7 mm o.d., Diamond Electro-Tech) covered with a DePeX membrane. The spatial resolution of the electrode was less than 0.5 mm. Pretreatment and calibration of the oxygen electrode was carried out according to Helder & Bakker (1985). A calomel electrode (Radiometer) was used as a reference. The electrodes were connected to a pico-ammeter (Keithly 480) and the signal recorded

on a battery-driven recorder (Minigor RE501, Goerz Electro). The oxygen electrode was mounted on a manually operated micromanipulator. Oxygen profiles were measured in the field around the root system of the tree (2 m from the trunk) and around a fiddler crab (*Uca* sp.) burrow. The tree was ca 3 m high, the crown 2 m wide and the root system with pneumatophores extended 2 to 3 m from the trunk. All measurements were made during daytime with exposed sediment surface. Vertical profiles were measured to describe the oxygen gradient at the sediment surface and at horizontal roots. Profiles with a 45° angle to the sediment surface were made to determine oxygen gradients around vertical structures.

After the O₂ measurements, the roots were dug up from the sediment and cut where the electrode had entered the root. The thickness of the cut root was measured with a ruler (precision 0.5 mm). Drawings of transverse sections of the roots were made using a Wild M7 microscope equipped with a drawing apparatus. Copies of the drawings were cut and weighed, and the aerenchyma part was calculated relative to the total area of the transverse section.

Results. The O₂ measurements showed high concentrations inside the roots compared to the surrounding sediment (Fig. 1). The pneumatophore contained between 63 and 88% of O₂ saturation (mean 78%) at 11 to 19 mm below the sediment surface (Fig. 1A). The O₂ concentration was highest in the outer part of the pneumatophore just inside the epidermis. A minimum surrounded by minor peaks was recorded in the center of the pneumatophore. The cable root deeper in the sediment (66 to 78 mm) showed a lower O₂ concentration (62 to 73%, mean 65% saturation) than the pneumatophores (Fig. 1B). The highest O₂ concentrations in the cable roots were also found just inside the epidermis. Another measurement on a different root system showed a similar difference in O₂ concentration between the pneumatophore (75 to 86%, 10 mm below the sediment surface) and the cable root (61 to 74%, 47 mm below the sediment surface). The O₂ gradients around both pneumatophores and cable roots were very steep (ca 0.5 mm). It is difficult to know exactly when the O₂ probe is inside or outside the roots and thus, if the recorded gradient is in the outer part of the root or in the surrounding sediment. The outer

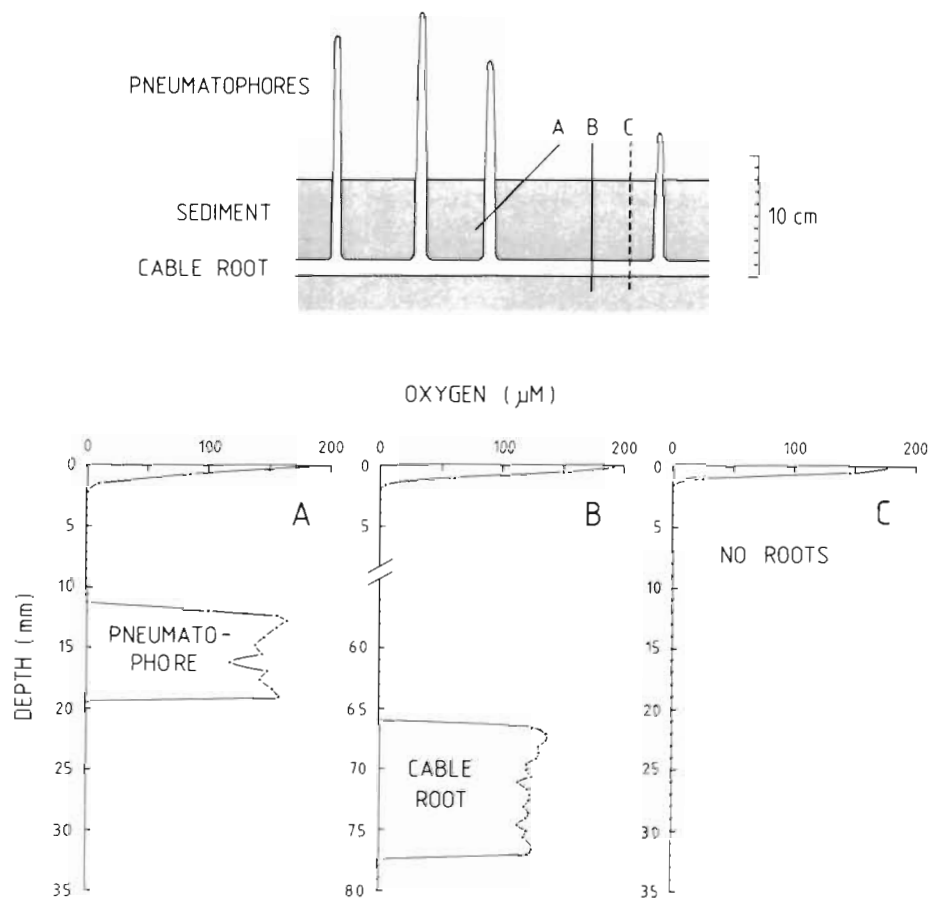

Fig. 1 O₂ concentration in and around roots of *Avicennia marina*. The measured profiles (A, B, C) are indicated on the upper panel. Profile C was measured as B but did not pass through the cable root. The outer limits of the roots are shown by the horizontal bars on A and B

limits of the roots on Fig. 1 were drawn on the basis of a symmetrical placement of the root (thickness was measured) within the O_2 peak. Fig. 1 indicates that most of the O_2 gradient is found in the surrounding sediment. The oxic zones at the surface of the sediments are wider (1.5 to 2.5 mm) and are similar in sediments with and without roots (Figs. 1 and 3).

Microscopical examination of sections of pneumatophores and cable roots revealed an extended aerenchyma tissue. A schematic transverse section of a pneumatophore is shown in Fig. 2. The aerenchyma constituted 69 to 80% ($n = 3$) and 81 to 85% ($n = 3$) of the transverse sections of pneumatophores and cable roots, respectively. Fundamentally, the structure of pneumatophores and cable roots was identical apart from the presence of chlorophyll in the outer part of the cortex in pneumatophores. The pneumatophores had, in addition, lenticels on the emerging parts.

The profiles measured around the crab burrow (Fig. 3) showed similar O_2 penetration from the sediment surface as recorded in sediments containing roots. However, the 45° profiles over the burrow wall interface (Fig. 3A, E) revealed that O_2 gradients were steeper (O_2 penetration 1 mm) than at the sediment surface.

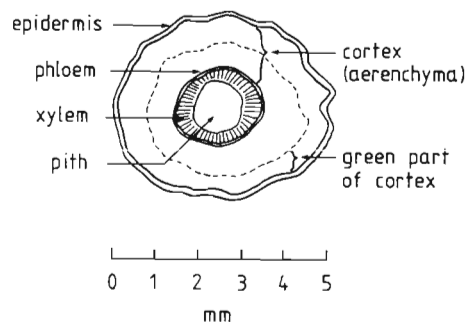

Fig. 2. *Avicennia marina*. Transverse section of an emerged pneumatophore, made 5 cm from the apex

Discussion. The high O_2 concentration found inside pneumatophores and cable roots in the field is in accordance with Scholander et al. (1955) and confirms the theory that the roots function as a O_2 transport system. Oxygen may be taken up through the lenticels in the pneumatophores and diffuse down into the root system. The presence of the necessary O_2 gradient for diffusion is proved in this study by the lower O_2 concentration in the cable roots compared to the pneumatophores. However, other mechanisms for O_2 transport have been suggested. Westermaier (cited in Chapman 1976) suggested that the water pressure at high tide forced air out of the lenticels and that air was sucked in again when the tide and pressure fell. Scholander et al. (1955) explained the falling pressure during inundation by O_2 utilisation. In one experiment these workers detected a faint rhythm which could be attributed to the light/dark conditions. In the present study high O_2 concentrations were detected in the outer part of the pneumatophores and to a smaller extent also in the outer parts of cable roots, which may be due to photosynthesis in the chlorophyll-containing outer layers of the emerging pneumatophores combined with reduced diffusivity in the transverse direction. The high O_2 concentration in the outer aerenchyma may, on the other hand, originate from the atmosphere via diffusion through the lenticel pores. However, further work is needed to determine the importance of photosynthetically produced O_2 inside the root system of mangroves.

It is well established from experimental studies that submersed and emergent macrophytes may release O_2 from their root systems (e.g. Armstrong 1982, Sand-Jensen et al. 1982). Due to experimental difficulties this phenomenon has not yet been examined in mangroves. If an extensive release of O_2 occurs, a wide oxic zone would be expected around the roots. However, we observed a very thin oxic zone (ca 0.5 mm), indicating a low release of O_2 . Similarly, Armstrong (1967, 1971)

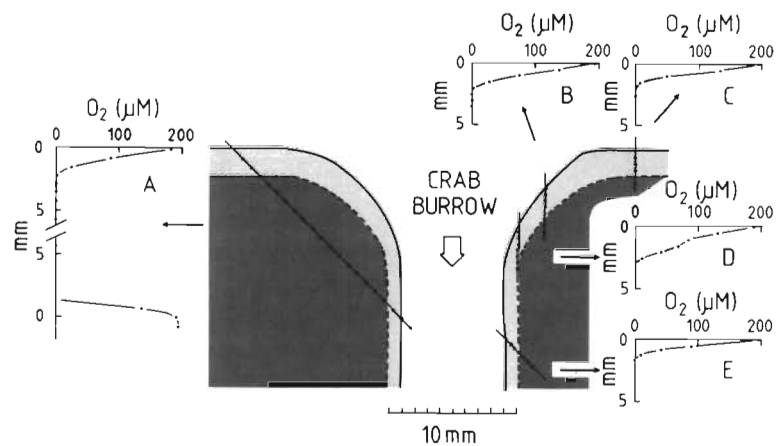

Fig. 3. O_2 measurements around a fiddler crab (*Uca* sp.) burrow. The positions of the measured profiles are shown by the lines on the drawing of the burrow. Light and dark stippled parts of the sediment indicate oxic and anoxic zones, respectively

measured only a subapical O₂ release from the roots of waterlogging-tolerant plants. These results indicate that gas-transporting roots generally contain outer layers almost impermeable to O₂. However, the O₂ gradient is highly dependent on the O₂ consumption rate of the microorganisms in the rhizosphere. A model of the relationship between the thickness of the oxygenated rhizosphere sheath around narrow rice roots and soil O₂ consumption has been presented by Armstrong (1982).

The O₂ profiles through the sediment surface in the tropical mangrove sediment were similar to those reported from temperate coastal sediments (e.g. Jørgensen & Revsbech 1985, Andersen & Helder 1987). The oxic zone in the crab burrow wall was narrower than that found at the sediment surface. This may be due to both higher O₂ uptake by heterotrophs in the burrow wall (Kristensen 1988) and photosynthesis at the sediment surface (Kristensen et al. unpubl.). Jørgensen & Revsbech (1985) similarly found a narrower oxic zone around polychaete tubes than at the surface of water-covered sediment. The oxic zone around the roots was narrow compared to that found in the crab burrow walls. This supports the theory of O₂ impermeable layers in the outer part of the roots.

The present study demonstrates the possibility of measuring O₂ concentration in the rhizosphere of mangrove trees. Thus, it will be possible to record O₂ gradients and diel O₂ variations inside and outside the root system, which may elucidate theories about gas transport in and around mangrove roots.

Acknowledgements. We are grateful to the Phuket Marine Biological Center for our stay there during the work. This work was supported by travel grant Nos. 81-5654 and 81-5655 from the Danish Science Research Council.

LITERATURE CITED

- Andersen, F. Ø., Helder, W. (1987). Comparison of oxygen microgradients, oxygen flux rates and electron transport system activity in coastal marine sediments. *Mar. Ecol. Prog. Ser.* 37: 259-264
- Armstrong, W. (1967). The use of polarography in the assay of oxygen diffusing from roots in anaerobic media. *Physiol. Plant.* 20: 540-553
- Armstrong, W. (1971). Radial oxygen losses from intact rice roots as affected by distance from the apex, respiration, and waterlogging. *Physiol. Plant.* 25: 192-197
- Armstrong, W. (1982). Waterlogged soils. In: Etherington, J. R. (ed.) *Environment and plant ecology*. John Wiley & Sons, Chichester, p. 290-330
- Chapman, V. J. (1976). *Mangrove vegetation*. J. Cramer, Leutershausen
- Christensen, B. (1978). Biomass and primary production of *Rhizophora apiculata* Bl. in a mangrove in southern Thailand. *Aquat. Bot.* 4: 43-52
- Frith, D. W., Tantanasiwong, R., Bhatia, O. (1976). Zonation and abundance of macrofauna on a mangrove shore, Phuket Island. *Phuket Mar. Biol. Ctr Res. Bull.* 10: 1-37
- Goebel, K. (1886). Über die Luftwurzeln von *Sonneratia*. *Ber. dt. bot. Ges.* 4: 249-255
- Helder, W., Bakker, J. F. (1985). Shipboard comparison of micro- and minielectrodes for measuring oxygen distribution in marine sediments. *Limnol. Oceanogr.* 30: 1106-1109
- Jørgensen, B. B., Revsbech, N. P. (1985). Diffusive boundary layers and the oxygen uptake of sediments and detritus. *Limnol. Oceanogr.* 30: 111-122
- Kristensen, E. (1988). Benthic fauna and biogeochemical processes in marine sediments. II. Microbial activities and fluxes. In: Blackburn, T. H., Sørensen, J. (eds.) *Nitrogen cycling in coastal marine environments*. John Wiley & Sons, Chichester, p. 275-299
- Sand-Jensen, K., Prahl, C., Stokholm, H. (1982). Oxygen release from roots of submerged aquatic macrophytes. *Oikos* 38: 349-354
- Scholander, P. F., Dam, L., Scholander, S. I. (1955). Gas exchange in the roots of mangroves. *Am. J. Bot.* 42: 92-98

This note was submitted to the editor; it was accepted for printing on February 15, 1988