

Experience with Azipod® propulsion systems on board marine vessels

The Azipod® drive is an innovative electric propulsion system for marine vessels with excellent manoeuvring capability and dynamic performance. Its motor sits inside a submerged pod which can be steered through 360 degrees and is coupled directly to an extremely short propeller shaft. The variable speed AC/AC drive produces smooth torque over the entire speed range. Azipod units with ratings of up to 25 MW are available. The new propulsion system is an attractive solution for various types of vessel, including icebreakers, offshore supply ships and cruise liners.

The original idea for the Azipod (Azimuthing Podded Drive) system was conceived more than a decade ago when the Finnish Maritime Administration began to look for ways to improve its icebreaker operations. Icebreakers must be capable of manoeuvring in such a way that they can break out of an ice channel in any direction in order to assist merchant ships using that channel. Investigations showed that a propulsion motor which could direct the thrust in any direction would be the ideal solution to this problem.

The Azipod drive system that was subsequently developed is a podded electric propulsion unit, freely steerable through 360 degrees. The company now building and marketing the system, ABB Azipod Oy of Finland, was established in 1997 to continue the activities of the former Kvaerner Masa-Azipod, part of the Kvaerner Masa-Yards Helsinki Shipyard. ABB Azipod Oy is

jointly owned by ABB, Kvaerner Masa-Yards and Italian shipyard Fincantieri.

Features of the Azipod propulsion system

The Azipod unit incorporates an electric (single or double-wound) AC motor that drives a fixed-pitch propeller directly via an extremely short shaft. The electric motor, located inside the pod **1**, is controlled by a frequency converter. Full torque is available from zero to nominal speed in either direction.

The Azipod electric propulsion unit features the advantages of conventional propulsion systems whilst eliminating their main

disadvantages **3**, **4**. Its benefits include:

- Excellent dynamic performance and manoeuvring characteristics, even in arctic conditions and harsh offshore environments.
- Long shaft-lines, rudders, stern thrusters, controllable-pitch propellers and reduction gears are eliminated.
- Good operational flexibility, resulting in low fuel consumption, reduced maintenance costs, lower exhaust emission levels and adequate redundancy with less installed power.
- A flexible design, allowing the Azipod unit to be built for pushing or pulling operations, low or high speeds, open water or ice conditions. The Azipod system can be equipped with skewed propellers with or without a nozzle.
- Ideal for Dynamic Positioning Systems (DPS).
- Reduced noise/vibration due to:
 - No reduction gear, long shaft-lines, transversal stern thrusters.
 - Excellent wake field, resulting in a low level of propeller-induced pressure pulses to the hull.
- Flexible machinery arrangement, resulting in easy installation and a free choice of location for the machine components; advantages include an increased payload and reduced design and construction costs, less tied-up capital due to optimized scheduling of subcontracted machinery deliveries, and better access for servicing of the prime movers.

Excellent results can be expected when the Azipod propulsion system is installed on any new ship. When the vessel design incorporates the Azipod concept from the beginning even better results can be expected.

Risto Pakaste
Kari Laukia
Max Wilhelmson
Jukka Kuuskoski
 ABB Azipod Oy

From icebreakers to cruise vessels

In the marine business, several years are usually needed to get a new innovation accepted by the market. This means that sys-

Azipod® is a registered trademark of ABB Industry Oy

tematic work and feed-back are necessary before a new product can be installed on a commercial vessel, where it then has to show a profit for its owner. When the Azipod concept was first studied with a view to using it on cruise liners, it became clear that a step-by-step approach was necessary, with new design aspects reviewed at each step:

- The Azipod unit installed on the waterway service vessel *Seili* proved that the idea itself was sound and showed that an Azipod system could be built and installed, is strong enough, and fulfils all the basic requirements of a ship's main propulsion.
- The first high-power propulsion unit installed on a commercial vessel, the 11.4-MW arctic tanker *Uikku*, proved the superior manoeuvring capabilities and efficiency of the concept, and has provided valuable in the experience high-power sector.
- The first pulling Azipod units were installed on board the icebreaker *Röthelstein* in 1995. The comparison with pushing types allowed some very useful conclusions to be drawn.

These vessels, by rapidly increasing the cumulative operating hours of the Azipod drive, provided information and feed-back that was invaluable for later designs.

On-board experience

M/S Seili

The first joint R&D project was the conversion in 1990 of *Seili*, a waterway service vessel owned by the Finnish Maritime Administration, into the world's first Azipod-propelled ship. The *Seili* is still in service and its 1.5-MW unit has operated faultlessly since the conversion.

M/T Uikku and M/T Lunni

The next ship to be equipped with the Azipod system was the 16,000-dwt product



The Azipod® unit, in which an AC motor sits inside a submerged pod that can be freely steered through 360 degrees **1**

tanker, the *M/T Uikku* **2**, built in 1978 in Germany. The conversion, involving an Azipod unit rated at 11.4 MW, was carried out in 1993. The ship was built to ice class 1A Super and the Azipod unit to DnV (Det

Norske Veritas) ice 10 class. In 1995 *Uikku's* sister ship, the *M/T Lunni*, was similarly converted. Both ships have been in heavy commercial use since conversion. Their combined operating hours total well over

16,000-dwt product tanker M/T Uikku with an 11.4-MW Azipod unit during turning tests in half-meter thick ice **2**





Conventional marine diesel-electric power plant and propulsion system 3

40,000, of which about 10,000 hours have been in ice-infested waters. In 1997 *Uikku* became the first western cargo ship to navigate the Northeast Passage. *Uikku* started its journey in Murmansk in western Russia at the beginning of September, arriving twelve days later in Providenya in eastern Siberia, south of the Bering Strait. The *Uikku* and the *Lunni* demonstrated the soundness of the basic design and construction chosen for the Azipod system.

I/B Röthelstein

At about the time the *M/T Lunni* was converted an Austrian icebreaker, the *I/B Röthelstein* 5, had two 560-kW Azipod units installed. This small river icebreaker introduced a new ice-breaking technique by attacking the ice with pulling propellers. The icebreaker is driven stern-first, with the Azipod units pulling the vessel.

The ice-breaking concept of moving astern with pulling Azipod units demonstrates an ice-breaking capability that

Azipod propulsion system and diesel-electric power plant. The Azipod system eliminates long shaft-lines, rudders, stern thrusters, controllable-pitch propellers and reduction gears. 4



surpasses all other technologies. It has also been tested with the *Lunni*. These tests showed that although the *Lunni* was not designed to operate stern-first in heavy ice, it was able to operate in the toughest conditions found in Finnish waters without ice-breaker assistance. Model and full-scale tests confirm that only 60% of the power needed when attacking the ice bow-first is needed for this mode of ice-breaking.

MSV Botnica

In February 1997 Finnyards Oy ordered two 5-MW Azipod units for the multipurpose ice-breaker *Botnica* for The Finnish Maritime Administration. This ship operates in the Gulf of Finland in winter and in the North Sea oil fields for the rest of the year. To perform its offshore duties the ship has DnV Autro dp-class¹⁾ equipment. The ship entered service in the North Sea in the summer of 1998. Excellent sea trial results showed that the ship is very well suited for offshore work. The Azipod units on the *Botnica* are the first such units to be used for offshore applications.

Supply ships for the Caspian Sea

In November 1997 Kvaerner Masa-Yards received an order for two small ice-breaking supply ships, the *Arcticaborg* and the *Ant-arcticaborg* 6, each powered by two 1620-kW Azipod units. The ice conditions in the northern Caspian Sea are very severe, so the Azipod units will operate as ice lathes.

Cruising with the Azipod system

The ‘full-scale’ applications described above and the very extensive R&D programme that accompanied them, provided the basis for the Azipod cruise liner concept that was finally realized at the end of 1995.

¹⁾ Det Norske Veritas Autro dynamic positioning class

Based on the good results obtained with the *Uikku* and *Lunni*, Miami-based Carnival Cruise Lines chose in the autumn of 1995 to install the Azipod system on its two Fantasy-class vessels *Elation* and *Paradise*. Each of these ships has two 14-MW Azipod units.

The largest cruise ships ever ordered are Royal Caribbean International's *Voyager of the Seas* and her sister vessel *Eagle II*, each with two 14-MW Azipod units and one 14-MW Fixipod (Fixed Podded Drive, a non-rotating Azipod unit). With the Azipod propulsion units and four 3-MW bow thrusters, the giant ships will be able to stay in a designated position in winds of up to 18 m/second from any direction.

New orders

The biggest customer for the new drives has been the co-developer of the Azipod concept, Kvaerner Masa-Yards, with eight ships delivered and a further seven on order. Recent contracts include new customers such as Meyer Werft in Germany and Fincantieri in Italy.

Meyer Werft and ABB signed major contracts in September 1998 for two cruise vessels, each equipped with 2 x 19.5-MW Azipod units. The Vantage-class vessels will be built for Royal Caribbean International at Meyer Werft in Germany. These are the most powerful Azipod units on order.

In September 1998 ABB received an order from the Italian shipyard Fincantieri for a cruise vessel which will be built for Holland American Line (HAL) and will be delivered in the year 2000. The Rotterdam-class vessel will feature an ABB main power plant with a medium-voltage distribution system and two Azipod units rated at 15.5 MW each. These are the first Azipod units to be installed at an Italian shipyard.

Carnival turns to the Azipod system

Carnival Cruise Lines (CCL) ordered its first Fantasy-class ships from the Kvaerner



I/B Röthelstein. The two 560-kW units of this small river icebreaker are the first pulling-type Azipod units to be installed.

5

Masa-Yards shipyard (formerly Wärtsilä Marine) in Helsinki in 1986. Over the years the Fantasy class has grown to be the big-

gest series of purpose-built cruise ships ever constructed. A total of eight ships of the same design have been built. For the

Arcticborg and Antarticborg ice-breaking supply ships, each powered by two 1,620-kW Azipod units, in the building dock. These vessels are driven stern-first when operating in severe ice conditions.

6



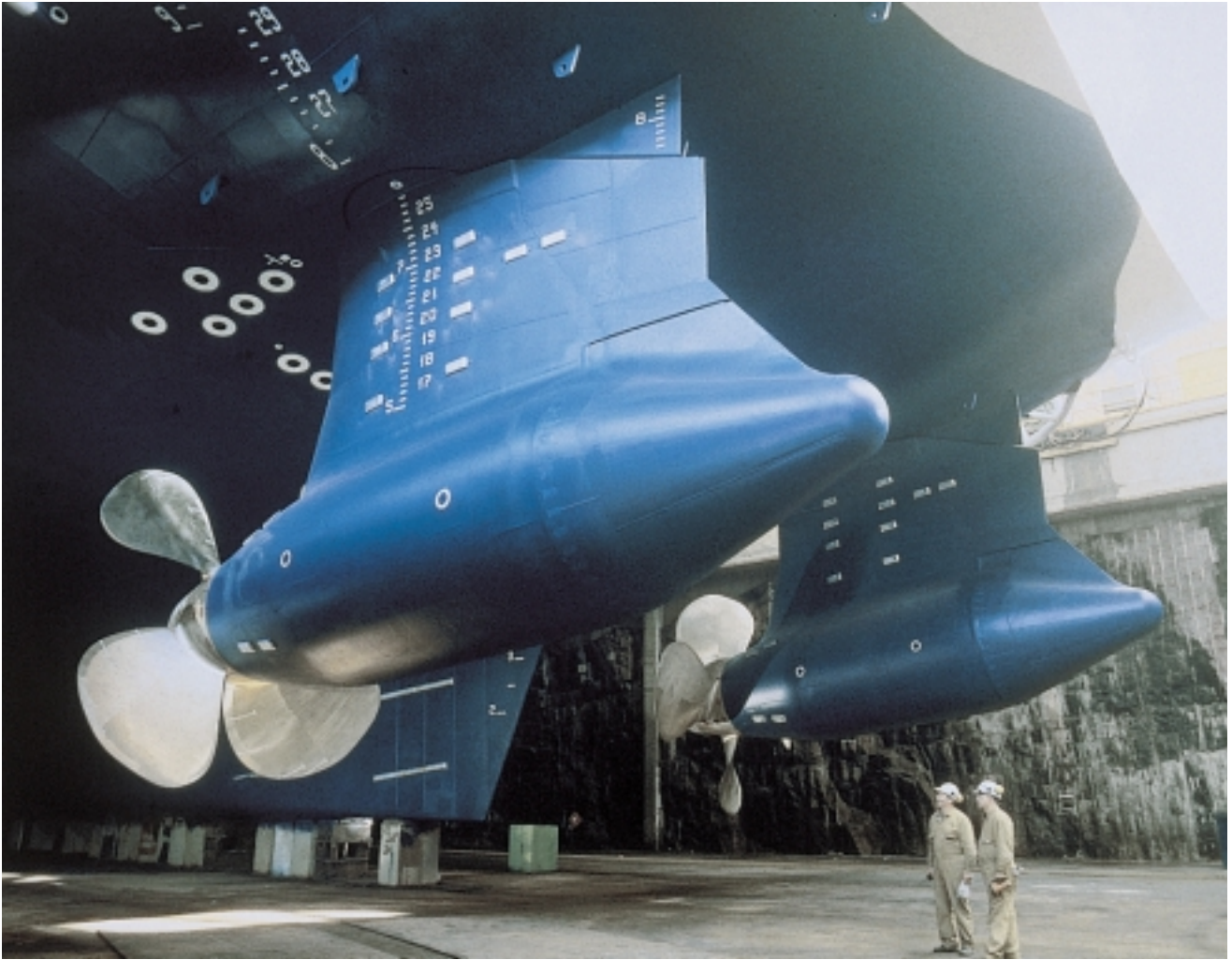

M/S Elation. This cruise liner, owned by Miami-based Carnival Corporation, has two 14-MW Azipod units.

7

two most recent units in the series, the *Elation* and the *Paradise*, CCL decided to fit the Azipod propulsion concept on the basis of its proven operation on service vessels and product tankers.

Conventional propulsion machinery

In a conventional marine drive system the propulsion machinery consists of a diesel-electrical power plant connected to a busbar. Power is directed to the propellers with two 14-MW cycloconverter controlled propeller motors. The drive system provides smooth torque and speed control over the entire speed range.

To ensure manoeuvrability, the ships

are equipped with three 1.5-MW tunnel thrusters in the bow and three in the stern. Two rudders are also mounted in the stern.

At the time it was designed, the *Fantasy* class represented the state of the art in propulsion and control technology. Today, most new cruise vessels are equipped with electric propulsion.

CCL and Kvaerner Masa-Yards were determined to remain in the technological forefront and in 1995 CCL chose to install Azipod propulsion in their ships instead of the conventional propulsion arrangement used previously. Two 14-MW Azipod units were subsequently installed on the *M/S Elation* and *M/S Paradise* **7**. Electrical

changes were minor: instead of running cables to the propeller motors, the cables were routed to the Azipod units and cabling work could be reduced since much of the equipment on the previous vessels did not have to be installed.

Changes to the steel construction were avoided. For example, shaft tunnels inside the ship were turned into freshwater tanks. The main changes made included a new construction for the Azipod unit wells and head boxes to allow the Azipod units to rotate 360°, and cover plates for the three stern thrusters that had been eliminated.

All equipment and castings related to the shaft lines were removed. The hydraulic system for the steering gear was replaced by

the Azipod hydraulic system. The cooling water system for the propulsion motors was extended to the Azipod room.

A summary of the changes in propulsion of the *Elation* compared with earlier ships in the Fantasy series is given in *Table 1*.

Design aspects of the installed Azipod propulsion system

Several aspects have to be taken into consideration when applying the Azipod concept: hull form, Azipod location, motor design parameters, propeller design and strength, hydrodynamic details, structural strength, vibration design and tuning, steering logic and operation modes, ship characteristics such as course stability and heeling, behaviour in black-out situations and redundancy.

The Azipod turning shaft is located in the same place as the old vertical rudder shaft. This allows full azimuthing angles and enough clearance to the baseline as well as sideways. The Azipod unit attachment to the ship's hull was designed on the basis of the model tests and 'full-scale' experience. The synchronous electric propulsion motor design values, power and torque curves were kept the same as those of the sister vessels, although savings in propulsion efficiency were expected.

Propellers

The fixed-pitch propeller diameter, at 5.2 meters, is the same as on the sister vessels. These propellers are the most powerful pulling propellers ever built. New operating modes created new challenges for the design. The task was successfully performed with the help of detailed hydrodynamic and FEM²⁾ calculations as well as model tests.

The hydrodynamic optimization procedure resulted in inward rotating pro-

pellors. The Azipod unit was slightly inclined downwards (six degrees) in order to obtain a good inflow for the propeller. The results obtained from model tests predicted an improvement in propulsion efficiency of several percent.

Steel structure

The structural dimensioning was based on two basic load conditions: maximum continuous loading in normal service and extreme loading (abnormal operation, eg, if the control of the Azipod system fails). A key design aspect was the adjustment of the dynamic behaviour. The excitation forces and moments were known from earlier projects. The excitation level is low due to the good wake field. The steel structure of the Azipod unit and ship hull was dimensioned such that the resonances are avoided in critical areas and at full power. Special emphasis was placed on the Azipod unit attachment to the hull.

Steering system

Steering of the Azipod units is carried out by an electro-hydraulic steering system **8**. A total of four hydraulic motors give the pod sufficient turning speed and redundancy. The steering logic had to be rethought (eg, the stability of the Azipod units, steering angles versus ship speed, power limitations and crash stop char-

acteristics). Ship behaviour calculations during extreme manoeuvring were performed. An analysis of the black-out situation was carried out, involving Azipod system behaviour, dimensioning of the emergency network and the starting sequence of the steering motors.

Redundancy was studied in order to prevent any failure in one pod from stopping the other. The Azipod units are mechanically, electrically and hydraulically independent.

Layout modifications on board the 'Elation'

Changes to the layout were kept to a minimum. The propeller motor room, which was no longer needed, actually offers new design possibilities because it makes available an additional 1200 m² of space. This space is as wide as the ship (32 m), 20 m in length and two decks high, the height of the propeller motors. In the case of the *Elation*, this room was used for additional waste handling equipment.

An incinerator and a grey water treatment plant were installed in the propeller motor rooms of the original design, and the old shaft tunnels were converted into freshwater tanks. Changes in the layout of the machinery spaces were minimal compared with the sister vessels. This was an advantage for the shipyard and the owner.

Table 1: Change in propulsion of the earlier Fantasy-class cruise ships and the M/S Elation, which is fitted with Azipod units

	<i>Fantasy</i>	<i>Power</i>	<i>Elation</i>	<i>Power</i>
Propulsion	2 × 14 MW	28 MW	2 × 14 MW	28 MW
Bow thrusters	3 × 1.5 MW	4.5 MW	3 × 1.5 MW	4.5 MW
Stern thrusters	3 × 1.5 MW	4.5 MW	none	
Rudders	2		none	
		37 MW		32.5 MW

²⁾ Finite Element Method

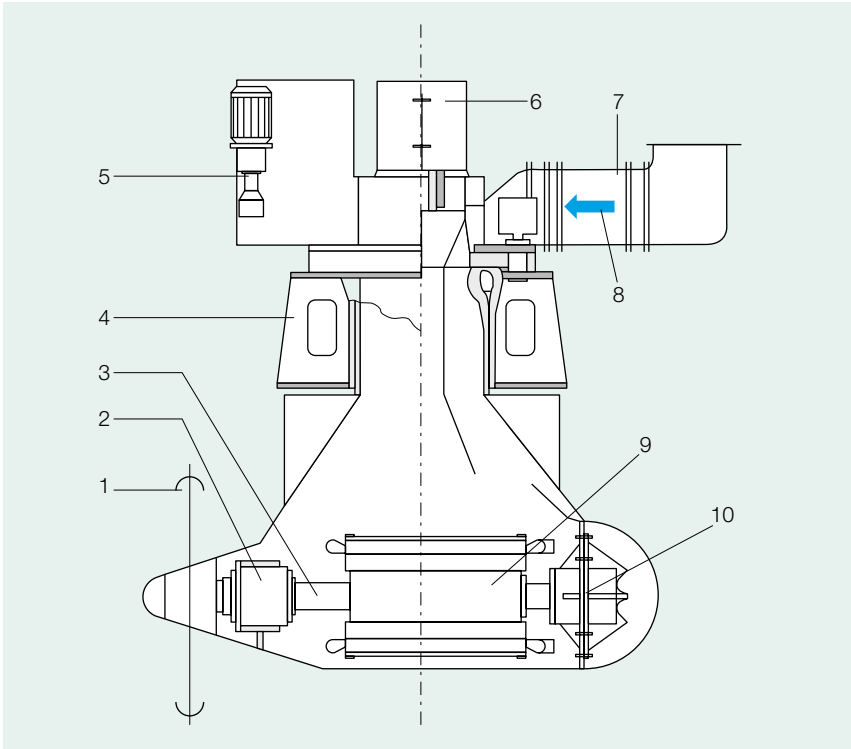

Main components of an Azipod unit

- | | |
|---------------------------|---|
| 1 Fixed pitch propeller | 6 Slipping unit (power/data transmission) |
| 2 Bearing, shaft seals | 7 Ventilation unit |
| 3 Shaft line | 8 Air cooling |
| 4 Installation block | 9 Electric motor |
| 5 Hydraulic steering unit | 10 Bearing |

8

Results of 'M/S Elation' sea trials

Efficiency

Good results were recorded during the sea trial in December 1997 in the Gulf of Finland. The increase in propulsion efficiency compared with the other Fantasy-class ships was 8%. The hull lines are the same on the *Elation* as on the previous ships in the Fantasy series. The only changes were the local modification around the Azipod units and the closing of the stern tunnels for the thrusters.

Manoeuvrability

The manoeuvrability of a ship is best demonstrated by its full-speed turning circle. The diameter of the turning circle of the *Elation* is about 30% smaller than for the previous

Fantasy-class vessels. The ability to turn the ship quickly gives the master a better margin for manoeuvring in tight situations and increases the safety of the ship.

The other important feature in a ship is its crash stop performance. The test was performed by reversing the propellers. An additional safety feature of an Azipod-propelled ship in the case of a crash stop is that the ship can be steered towards the desired stopping point.

Passenger comfort

A reduction in noise and vibration was also observed during the sea trials. This is mainly due to the very good wake field of the pulling propeller and the resulting reduction in pressure pulses from the propeller to the hull. Passengers notice the biggest difference in the confined area operations and

during harbour manoeuvres. The absence of the stern thrusters and the rudders makes a big difference to passenger comfort.

Conclusions

Recent experience with the combination of diesel-electric power plant and Azipod propulsion system has shown the concept to be an attractive solution for various types of vessels. The improved total efficiency, in addition to other advantages, such as enhanced manoeuvrability, redundancy, reduction of equipment, simplicity and the proven reliability of the design, can be realized in most ship projects. The suitability of the concept for cruise ships is obvious, and has been proved by the successful sea trials with *M/S Elation*.

The feasibility analysis for a new project should always be carried out together with the shipbuilder. This is because the Azipod propulsion concept changes not only the way ships can be designed and operated but also how they are built.

Authors

Risto Pakaste
 Kari Laukia
 Max Wilhelmson
 Jukka Kuuskoski
 ABB Azipod Oy
 Laivanrakentajantie 2
 FIN-00980 Helsinki
 Finland
 Telefax: +358 10 22 26060
 E-mail:
 risto.pakaste@fiazmail.abb.com
 kari.laukia@fiazmail.abb.com
 max.wilhelmson@fiazmail.abb.com
 jukka.kuuskoski@fiazmail.abb.com