

EE406 - MTU Radio Telescope Project
Design and Fabrication of the Radio Receiver

Submitted by
Aaron Koslowski
To : Dr. Warren F. Perger

January 13, 1999

Contents

1	Introduction	5
1.1	Objective	5
2	Overall Requirements of the Receiver	6
3	RF Section	9
4	IF Filter	11
4.1	Filters	11
4.2	Amplifiers	11
4.3	Testing and Results	11
4.4	Conclusions	12
5	IF Section	13
5.1	Design Considerations and Trade-offs	13
5.1.1	Initial Design Problems and Issues	13
5.1.2	Mixer Design	13
5.1.3	Amplifiers	14
5.1.4	Narrow-band Filters	14
5.1.5	Overall System Design	14
5.2	Component Specifications	15
5.2.1	Mixer Specifications	16
5.2.2	Amplifier Specifications	16
5.2.3	Filter Specifications	16
5.3	Fabrication of PCB and Layout	17
5.3.1	Width of the Stripline	17
5.3.2	Connectors for Input and Output	17
5.4	Testing and Results	19
5.4.1	Test Set-up	19
5.4.2	Test results	19
6	Local Oscillator	20
6.1	Introduction	20
6.2	Design	20
6.3	Testing	22
6.4	Conclusions	22

7	Frequency Multiplier	23
7.1	Introduction	23
7.2	Design	23
7.2.1	Harmonic Generator	23
7.2.2	Amplifiers	23
7.2.3	Filter	25
7.3	Testing Results	25
7.3.1	Harmonic Generator	25
7.3.2	Amplifiers	25
7.3.3	Filter	25
7.4	Conclusion	26

List of Figures

2.1	Block Diagram of MTU Radio Telescope Receiver (parentheses indicate minimum power levels)	7
3.1	RF-Section schematic	10
5.1	Block diagram of Intermediate Frequency (IF) section	13
5.2	Typical Biasing configuration of the MAR-6 amplifier	15
5.3	Schematic diagram of PCB layout	18
6.1	Oscillator design.	21
6.2	Equivalent network for the crystal.	22
7.1	Harmonic generator circuit.	24
7.2	Inductor	24
7.3	Amplifier biasing circuit	25

List of Tables

5.1	Gain measurements for various RF input signal levels	19
-----	--	----

Chapter 1

Introduction

This document was created as a part of the Michigan Technological University class **EE406** - *Microwave Devices and Circuits* taught by Dr. Warren Perger during Fall Quarter, 1996. The purpose of this document described herein is to present the overall requirements of the radio receiver for the MTU Radio Telescope Project and to detail the design considerations and trade offs involved in the design of each section of the receiver. The key personnel involved include Dr. Warren Perger, John Miller, Charles Sannes, the project leader Aaron Koslowski, and the five design teams - Predrag Janic and David Rottier, **RF section**; Robert Rokosky, Jr., **IF filter section**; Alan Hollo and Balasubramanian Ramachandran, **IF section**; Paul Stanowski, Cornelius Strong, and Mark Wagoner, **local oscillator section**; Brian Steward and Samuel Hon Yin Vu, **frequency multiplier section**. This document serves to describe the design issues, fabrication and the layout of the radio telescope receiver and to present test results. Possible extensions or improvements in the design will be presented should future users wish to implement them.

1.1 Objective

The purpose of the radio receiver project is to design a receiver for an interferometer system consisting of two parabolic dishes spaced 30 meters (100 feet) apart on a 40 acre parcel of land near Atlantic Mine, MI - approximately seven miles from campus. The radio receiver is designed at 1420 MHz or 21 cm for measurement of the Doppler shift of the hyperfine line of the ground state in neutral hydrogen. The critical requirements of the receiver include high gain on the order of 90 - 130 dB and low noise figures. The original design was conceived by Guillermo Acevedo, currently a graduate student in EE in the electromagnetics option, along with Dr. Richard Campbell who is currently at Triquint Systems.

The overall receiver consists of the following sections:

- Front end receiver antenna and Low noise amplifier (LNA).
- RF Section consisting of one stage of down-conversion from 1420 MHz to 377.5 MHz and bandpass filters.
- Local Oscillator (LO) and frequency multiplier unit.
- IF section consisting of second stage of down-conversion from 377.5 MHz to 30 MHz followed by narrow-band filtering and post amplification.

Chapter 2

Overall Requirements of the Receiver

The general block diagram of the radio receiver is as shown in figure 2 on the following page.

The first stage of the receiver is a low noise amplifier (LNA) amplifier at the front end of the horn-fed antenna, followed by the RF section and the IF (Intermediate Frequency) section that results in an IF signal of 30 MHz. Typically in radio astronomy, the noise temperature of the receiving antenna is very low, hence the overall gain of the receiver required is very high along with the stringent requirements of low noise figures. This is in order to prevent the receiver noise from dominating the measured signal. In the design of the system, the base line value of 90 dB - 130 dB was used.

The Low Noise Amplifier (LNA) at the front end of the receiver plays a very crucial role in determining the overall performance of the system. Typical requirements for the LNA in radio astronomy are noise temperatures as low as 50 K and a gain of 20 - 25 dB. The input signal at 1420 MHz is initially fed to the LNA and the resulting output is then down converted in two stages using the basic configuration of a super heterodyne receiver. The first stage is the RF section where the input signal of 1420 MHz is mixed with the local oscillator signal (LO) of 1042.5 MHz to result in an RF signal of 377.5 MHz. This signal is then amplified and filtered using bandpass filters and is then fed to the IF section.

In the IF section, the signal of 377.5 MHz is down-converted to the baseband value of 30 MHz by mixing with the LO signal of 347.5 MHz obtained by a frequency multiplier unit. The multiplier unit does a $\times 5$ (times 5) multiplication on the basic signal of frequency of 69.5 MHz derived from the crystal oscillator. The signals obtained from both parabolic dishes are filtered using narrow-band filters with a center frequency of 30 MHz. Subsequent signal processing is performed by using the amplitude and phase information from each of the signals.

The gain and the power level requirements for the overall receiver and each individual section are determined as follows: Typical radio astronomy intensity levels for the brightest radio source is 10,000 Janskys ($1 \text{ Jansky} = 10^{-26} \frac{W}{Hz.m^2}$) [5] and for dimmer sources, the values are around 100 Janskys. For the radio receiver to be able to conveniently handle the levels, the overall gain required is high. In typical receiver designs, it is always convenient to work in terms of dBm and the conversion is carried out as follows. First, consider the brightest source of 10,000 Janskys = $10,000 \times 10^{-26} = 10^{-22} \frac{W}{Hz.m^2}$. The operating frequency is 1420 MHz and hence the intensity level equals $\approx 10^{-22} \times 10^{12} = 10^{-10} \frac{W}{m^2}$. Since parabolic dishes with 3 meter diameters are being used, the aperture area is $\pi r^2 = \pi \times (1.5)^2 = 7.06m^2$; therefore the intensity level equals $\approx 10^{-10} \times 7.06 \text{ Watts} = 10^{-9} \text{ Watts}$. This equals -90 dBm for the brightest source and since the least bright source is three orders of magnitude less than this, the level equals -120 dBm.

In order to be able to measure the signal at the front-end in presence of noise, we require a high gain for the system, as shown by the various gains and power levels illustrated in the figure. The values in parentheses correspond to the least bright sources and hence a windowing range is obtainable for the system. The approximate gain for each section is listed below:

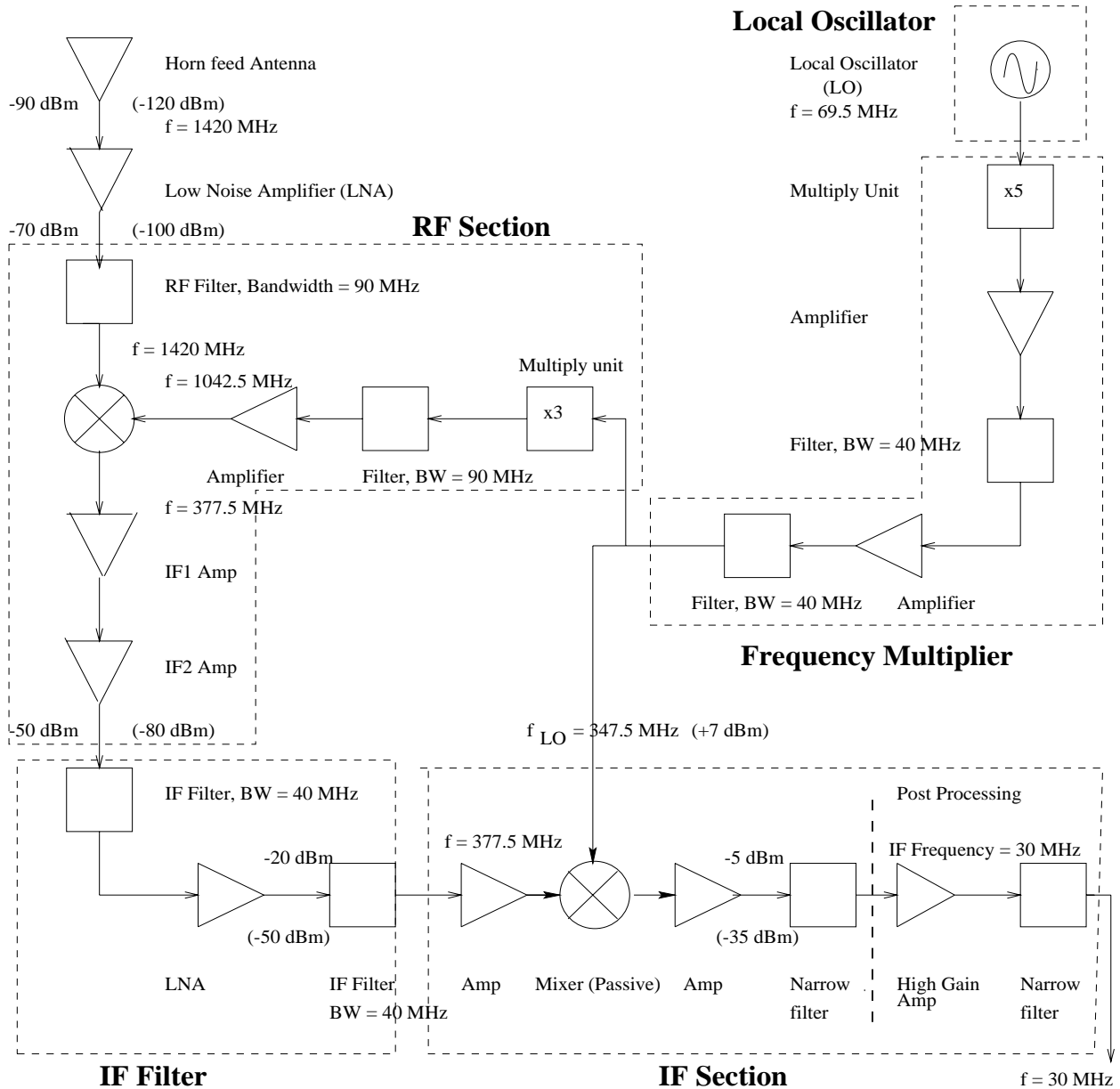

Figure 2.1: Block Diagram of MTU Radio Telescope Receiver (parentheses indicate minimum power levels)

- Low Noise Amplifier (LNA) - 20 - 25 dB
- RF Section - 15 - 20 dB
- Bandpass filters and LNA - 25 - 30 dB
- IF Section - 15 -20 dB
- High Gain Amplifier - 45 -60 dB

The high gain amplifier boosts the signal level to the value required to record the amplitude and phase information.

Chapter 3

RF Section

The purpose of the radio frequency section is to take the radio frequency signal of 1420 MHz after it is obtained from the low-noise amplifier (LNA) and mix it down to an intermediate frequency of 377.5 MHz. It is also desired to obtain a gain around 30 dB in this section. In order to obtain these results, the circuit board shown in figure 3.1 was built. In this design, a hairpin filter is used in order to filter the radio frequency and the local oscillator, where the radio frequency filter is centered at 1420 MHz and the local oscillator filter is centered at 1042.5 MHz.

The amplifiers used in this design are the MAR-4, with a gain of about 8 dB and a maximum output of 12.5 dBm, and the MAR-6, with a gain of about 16 dB and a maximum output of 2 dBm. The MAR-4 was used to amplify the local oscillator signal so that it would satisfy the operational specifications of the SRA-2000 frequency mixer (+7 dBm LO, up to +1 dBm RF). The MAR-6 amplifiers were used to amplify the intermediate frequency - the output of the RF section. These amplifiers were used in series in order to achieve a gain of approximately 30 dB.

This design also calls for a frequency multiplier. It is designed to produce the third harmonic of the 347.5 MHz local oscillator signal, or 1042.5 MHz. However, additional research was needed to produce this multiplier, and because of time constraints, this circuit was not physically constructed.

The gain obtained from the RF section was measured to be 30 dB. The output of this section was measured to be 0 dBm with an input of -30 dBm. The output appeared to be rich in harmonics, but this will be eliminated in the IF filter section.

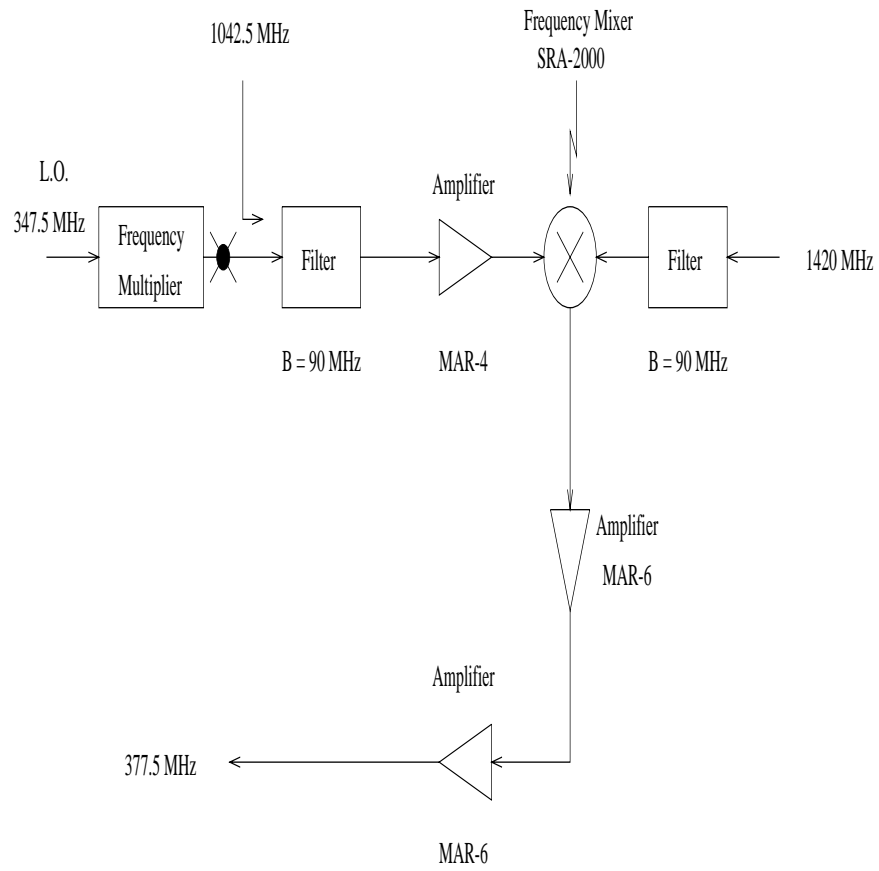

Figure 3.1: RF-Section schematic

Chapter 4

IF Filter

The IF filter section of the radio telescope receiver operates on a 377.5 MHz input signal. Two operations are performed on the input - filtering and amplification. Concerning the filtering, two narrow filters are used to attenuate any harmonics and noise that may accompany the input signal. The gain requirements for this section are met by using two amplifiers. The IF filter section is designed to have a gain of 20-30 dB and a bandwidth of 40 MHz. These figures will be compared with the results shortly. Each of the two types of components will now be discussed in more detail.

4.1 Filters

The filters for this section are third order narrow filters and were designed using Eagle software. Both filters are designed to have a bandwidth of 40 MHz centered around the signal frequency of 377.5 MHz. The Eagle software design was produced on printed circuit board for use in the IF filter section.

4.2 Amplifiers

The make of the amplifiers used in the IF filter section are GTE-506800 Model QB-723 from the Q-bit Corporation. They are powered by +15 V_{DC} . The output of each amplifier has a gain of 25 dB at all frequencies as compared to the input.

4.3 Testing and Results

The components are setup in a filter-amplifier-filter-amplifier configuration as shown by Figure 2. This was done to distribute the filtering and amplifying stages within the IF filter section to reduce any distortion that could occur. Once constructed, the frequency response of the section was tested. It was found that the gain of the system at the operating frequency of 377.5 MHz was 28 dB. The 3 dB bandwidth points are at 372 and 407 MHz. This gives a 3 dB bandwidth of 35 MHz. The response drops off quickly beyond these points, greatly attenuating these frequencies.

Analyzing the gain, the amplifiers each contribute 25 dB of gain. However, the filters have 10-12 dB of attenuation each. It can be shown mathematically that 28 dB is a reasonable result. This meets the design specification of 25-30 dB of gain. The relatively large amount of attenuation by the filters is a trade off made to accomplish a narrow bandwidth. The 3 dB bandwidth of the frequency response is 35 MHz (372-407 MHz). This result reveals two inconsistencies with the design criteria. First, the bandwidth was designed to be 40 MHz instead of 35 MHz. Second, the incoming signal frequency of 377.5 MHz is not centered within the 3 dB bandwidth. These issues can be resolved by looking at the performance of the filters. They were

designed on the computer software to have a 40 MHz bandwidth centered around 377.5 MHz. However, in applying the filters to the IF filter section, they did not behave exactly as the software predicted. This is not unexpected, and the frequency response is acceptable considering the extra variables introduced by the amplifiers, wires, and connectors. Although the frequency response is not exactly what was predicted, the important criteria that the 377.5 MHz signal is passed with maximum gain has been met.

4.4 Conclusions

To conclude, the IF filter section of the radio telescope receiver will take the input signal at 377.5 MHz from the RF section, and return an output signal of the same frequency with 28 dB of gain while the harmonics and noise outside of the 35 MHz 3dB bandwidth are severely attenuated. These results match reasonably well with the original criteria of 25-30 dB of gain and a 40 MHz bandwidth. It is expected that the IF filter section will perform to the specifications of the radio telescope receiver.

Chapter 5

IF Section

5.1 Design Considerations and Trade-offs

Figure 5.1 illustrates the IF section of the receiver and the sections below discuss each of the submodules in detail. The IF section essentially consists of the mixer, amplifiers and the narrow-band filters.

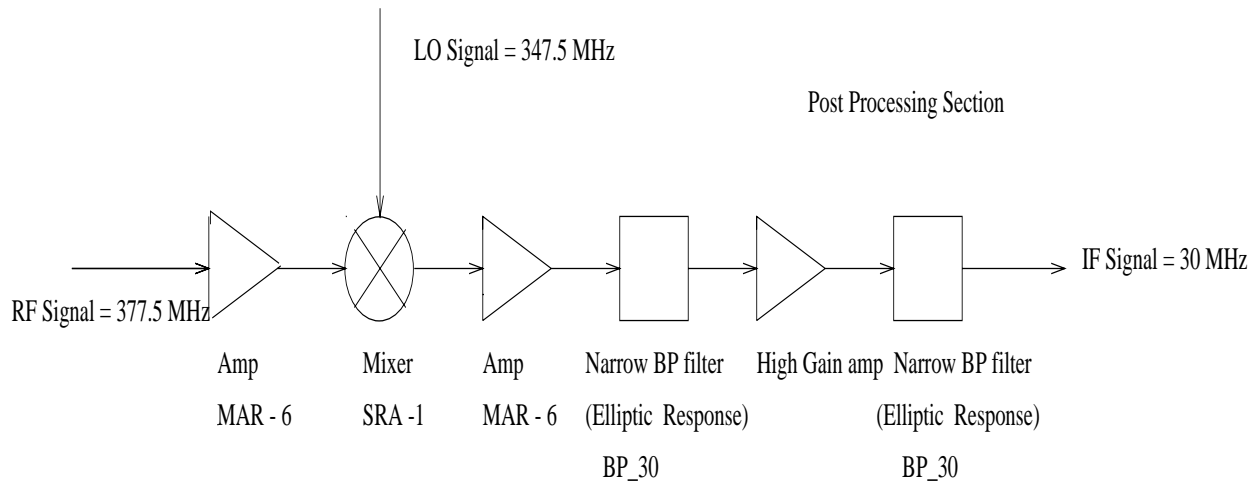

Figure 5.1: Block diagram of Intermediate Frequency (IF) section

5.1.1 Initial Design Problems and Issues

Initially, the amplification in the IF section was done after the mixing process and a cascaded section of two amplifiers was used. This, however, results in saturation of the second amplifier as each one of the amplifiers has a maximum output of +2.5 dBm. Saturation results in non-linear distortion and hence the design was modified to one stage of amplification before the mixing at 377.5 MHz and one at the IF frequency of 30 MHz [1].

5.1.2 Mixer Design

The mixer is a key component in the overall receiver and it transfers the modulation from the RF signal to the IF via the nonlinear mixing process. This nonlinearity generates spurious products that are undesirable.

The key concerns for the mixer are low spurious products, low Noise Figures (NF), conversion gain, low LO drive level, and low DC power consumption. Isolation between the LO, RF and IF ports is also important [4].

In this particular IF section, the RF signal of 377.5 MHz and the LO signal of 347.5 MHz are mixed, resulting in an IF signal of 30 MHz. The choice of mixers lies between active mixers and passive mixers. Passive mixers result in conversion loss while active mixers provide conversion gain on the order of 6-9 dB, reducing the need for additional IF stages. However, active mixers were used initially, but the active mixer (UNCL-R1H) requires a LO drive of +17 dBm which is substantially higher than the drive level required for the passive mixers of the Level 7 type. Hence, a passive mixer SRA-1 was chosen in the design [7].

- Features of the mixer chosen include:
 - Low LO drive level
 - insensitive to IF load

5.1.3 Amplifiers

In order to amplify the low level signal output of the mixer, an amplifier is used to provide a gain of approximately 15 - 20 dB. The resulting amplified signal is filtered using a narrow-band elliptic filter and then subsequent processing is performed.

- Features of the amplifier include:
 - Cascadable
 - Excellent repeatability
 - Wide Bandwidth: DC - 2000 MHz
 - low noise figure: 2.8 to 3.6 dB typical
 - high output power: +2.0 dBm typical

5.1.4 Narrow-band Filters

The IF filter sets the noise figure for the receiver and provides isolation. Using EAGLE Layout Editor (CadSoft), 3rd order hairpin Chebyshev bandpass filters on a microstrip line were designed, but due to the low baseband frequency of 30 MHz and high degree of isolation required, the physical dimensions increase substantially and the insertion losses are very high [9]. Therefore, bandpass filters with an elliptic response and passband of 28 - 33 MHz were chosen. The detailed specifications of the filters are outlined in the next section.

- Features of the bandpass filter include:
 - Flat group delay and low pulse distortion
 - Choice of connectorized models

5.1.5 Overall System Design

The integration of the submodules in the IF section was accomplished as follows:

The passive mixer chosen in the design is matched at the RF, LO and the IF ports to 50 ohms. The RF signal from the previous section is first amplified and then fed to the mixer. The resulting IF signal at 30 MHz is then again amplified and subsequently filtered using a narrow-band filter with an elliptic response.

The MAR-6 amplifiers chosen were high gain by providing up to +2.0 dBm output and the typical biasing configuration is as shown in figure 5.2.

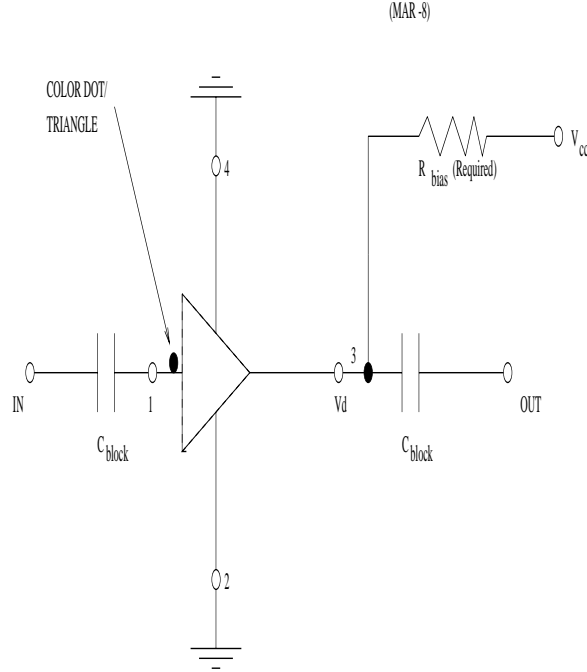

Figure 5.2: Typical Biasing configuration of the MAR-6 amplifier

The choke (RFC) is optional and the biasing resistor is chosen to typically satisfy a design constraint of the nominal voltage at pin 3 V_d being equal to 3.50 volts and the current equal to 16 mA. Further, the minimum voltage drop across R_{bias} should be 0.5 volts. Since the power supply voltage is equal to 12 volts, the nominal value of the resistance can be found as

$$R_{bias} = \frac{V_{cc} - V_d}{I_{nominal}} = \frac{12 - 3.5}{16mA} = 531\Omega.$$

Using the nearest standard value, we can use a 560 Ω resistance value. Hence, $R_{bias} = 560\Omega$.

The capacitors, C_{block} , at the input and the output of the circuit are used in order to block DC and present a very low impedance at the operating frequency for AC. The design criteria used was that the maximum capacitive reactance should not be greater than 5 Ω at the operating frequency [7]. In this case, we chose the value as 0.5 ohms and hence

$$\frac{1}{j\omega C} = 0.5\Omega$$

where $\omega = 2 \times \pi \times f$ and $f = 377.5$ MHz for one of the amplifiers and $f = 30$ MHz for the other amplifier. The tighter bound is used, and therefore C turns out to be equal to approximately $10nF = 0.01 \mu F$. Chip capacitances of this value were used in the actual design layout.

5.2 Component Specifications

All of the components were ordered from Mini-Circuits, a New York based company specializing in RF/IF products, while the catalog and comprehensive designers guide were used to specifically select the required components.

5.2.1 Mixer Specifications

As described in the previous chapter, the choice of mixer lies between active and passive mixers and in this case, a passive mixer was chosen due to the low LO drive level available (+7 dBm) but also results in reduced power consumption. The data specs of the mixer are as shown below [7].

- Passive, Level 7 Mixer, 0.5 - 500 MHz:
 - Model No: SRA-1, +7 dBm LO, upto +1 dBm RF
 - Frequency (MHz)
 - * LO/RF : $f_L - f_U$, 0.5 - 500
 - * IF : DC - 500
 - Conversion Loss (dB)
 - * Mid-band: Mean-5.11 Std.Deviation-0.09, Max-7.0 Total Range: Max-8.5
 - LO-RF Isolation (dB)
 - * Typical: 35 - 50 dB, Minimum: 25 - 45 dB
 - LO-IF Isolation (dB)
 - * Typical: 30 - 45 dB, Minimum: 20 - 35 dB

5.2.2 Amplifier Specifications

Broadband monolithic amplifiers from DC to 2 GHz and up to a 12.5 dBm output were chosen for this design. The data specs of the amplifier are shown below [7].

- Monolithic Amplifiers, 50 ohms
 - Model No: MAR-6 up to +2.0dBm output
 - Frequency (MHz)
 - * $f_L - f_U$: DC - 2000
 - Gain, dB Typical (at MHz)
 - * At 100 MHz: 20.0 dB, 500 MHz: 18.5 dB
 - Maximum Power (dBm)
 - * Typical Output: +2.0 dBm
 - Dynamic Range, Typical
 - * Noise Figure: NF 3.3 dB, IP3 : +14.5 dBm
 - Nominal DC Power at Pin 3
 - * 3.5 volts, 16 mA

5.2.3 Filter Specifications

A bandpass filter with an elliptic response and a center frequency of 30 MHz was chosen to satisfy the design constraints. The data specs are shown below. The high gain amplifier following the narrow-band filter has an N-type connector, so the filter connector has also been chosen as N-type [7].

- Bandpass filter, 50 ohms, 10.7 to 70 MHz
 - Model No: N-BP-30, elliptic response

- Center Frequency (MHz)
 - * 30 MHz
- Passband I.L. 1.5 dB MAX(MHz)
 - * 27.0 -33.0 MHz
- 3 dB Typical Bandwidth
 - * 25 - 35 MHz
- Stopbands
 - * I.L. > 20 dB: 22 and 40 MHz
 - * I.L. > 35 dB: 3.2 and 99-1000 MHz

5.3 Fabrication of PCB and Layout

After all the components have been chosen, the next step in the design was placement and routing on the PCB. This was accomplished using the EAGLE Layout editor available from CadSoft [6]. General guidelines and hints for using this software were available from the handout prepared by John Miller for his circuit fabrication class. Typically all dimensions are in inches and 1000 mils = 1 " and 2.54 cms =1". Components are placed on the top and the traces run on the bottom layer. The overall schematic of the placement on the board is shown in figure 5.3.

5.3.1 Width of the Stripline

The width of the connecting stripline was determined as follows:

Since all of the components are matched to 50 ohms, including the mixer at the RF, LO and IF ports and the amplifiers, the width of the stripline required Z_o also equals 50 ohms. Using the formula below, the stripline width can be calculated as:

$$Z_o = \frac{b}{4\omega\sqrt{\epsilon_r}} \times \eta.$$

where Z_o is the desired impedance, equal to 50 ohms in this case, η is the characteristic impedance and equals 377 ohms, ω is the width of the stripline to be calculated, b is the thickness of the board and ϵ_r is the relative dielectric constant of the board material. In our case, the board thickness equals $\frac{1}{16}$ " = 0.0625 " and ϵ_r for the board material equals 4.9, hence ω equals

$$w = \frac{0.0625 \times 377}{4 \times \sqrt{4.90} \times 50} = 0.05610''.$$

This corresponds to 56.10 mils and the closest available value in EAGLE Layout is 50 mils and hence the width of the stripline used was 50 mils. When the case is grounded, then the bottom of the PCB is coated with copper and therefore, the width of the copper stripline turns out to be 100 mils.

5.3.2 Connectors for Input and Output

SMA connectors are used to connect all the inputs including the RF, LO and the power supply ports. The output of the IF section is connected through an N-type coaxial connector to the narrow-band bandpass filter. This output is then fed through the coaxial connector to the high gain amplifier and is finally sent to another narrow-band filter resulting in the 30 MHz IF signal.

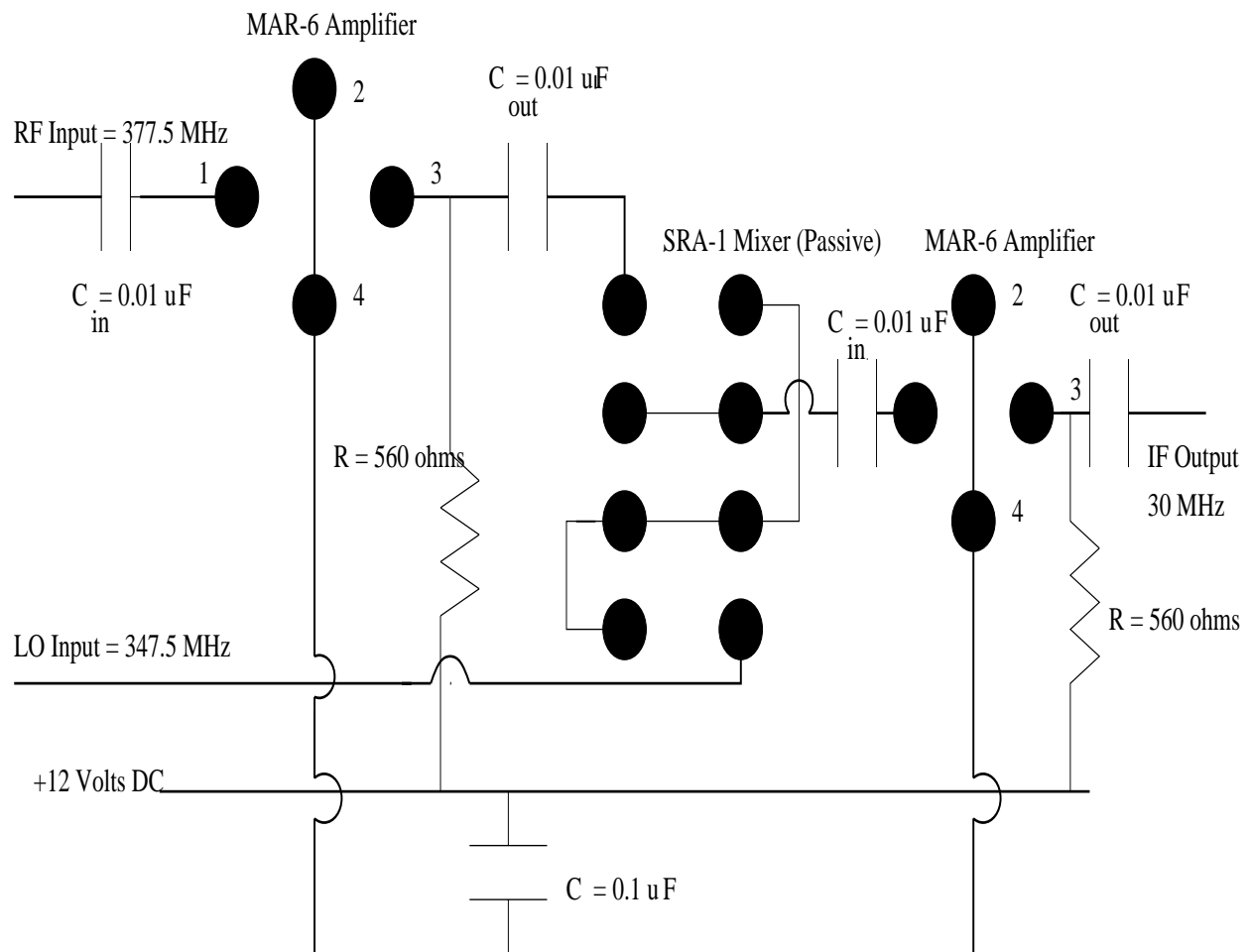

Figure 5.3: Schematic diagram of PCB layout

5.4 Testing and Results

5.4.1 Test Set-up

The basic test set-up consists of HP signal generators used as the local oscillator (LO) and the RF signal source. The signal generators are variable in frequency and can be used to tune to a single frequency. The power levels of the signals from the signal generator are also adjustable from -120 dBm to +10 dBm. The HP spectrum analyzer is used as the output test device to validate the circuit. Initially, the LO signal is adjusted to 347.5 MHz and the power level is set to +7 dBm, while the RF signal frequency is 377.5 MHz and the signal level is varied between -60 dBm and -10 dBm. The output of the circuit is then connected to the spectrum analyzer to observe the 30 MHz IF signal. During the initial phases of testing, minor problems were encountered, but the final output after the narrow-band elliptic filter was a clean signal of 30 MHz. Further validation of the circuit was accomplished by lowering the LO signal drive and the RF signal power and correspondingly; correspondingly, the output levels on the spectrum analyzer varied accordingly. The gain of the circuit was measured by calibrating the spectrum analyzer for a specific value of the RF input and measuring the output of the filter.

5.4.2 Test results

The results for the gain obtained are tabulated below for various values of the RF power level.

LO Signal Level (dBm)	RF Input (dBm)	IF Output (dBm)	Gain in dB)
+10	-54	-40	14
+10	-44	-33	11
+10	-34	-21	13

Table 5.1: Gain measurements for various RF input signal levels

An approximate gain of 15 - 20 dB is obtained from the IF section and, upon comparison with the specifications in the data sheets, the passive mixer should result in an 8dB loss while each of the MAR-6 amplifiers ideally provides a gain of 18.5 dB. The difference in the values is due to the non-ideal connections in the circuit and the gain decrease of the amplifier at higher frequencies. The circuit operates linearly over five decades of change in the RF power level with approximately a constant gain.

Chapter 6

Local Oscillator

6.1 Introduction

The local oscillator (LO) is literally the “heartbeat” of any superheterodyne receiver, and the receiver used in the MTU radio telescope is of this type. A signal generated by the LO of the MTU Radio Astronomy Receiver is multiplied a number of times to mix with the incoming 1420 MHz signal. The resultant intermediate frequency (IF) is then mixed down to recover the desired signal. This section of the project involved the designing and building of the LO to produce a “clean” 69.5 MHz signal.

6.2 Design

The LO design was based on a Butler emitter-follower circuit which uses a crystal, tuned to the desired frequency, for stability. The design of this crystal oscillator is based on the work of Dr. Richard L. Campbell, “A Clean, Low-Cost Microwave Local Oscillator” [2]. His design produces a 2.1-2.3 GHz signal from a 90 MHz crystal. This design incorporates the beginning stage of Dr. Campbell’s oscillator. However, it does not use any of the frequency multipliers. The MTU radio telescope oscillator uses a crystal tuned to 69.5 MHz, as opposed to 90 MHz, as well as different values of the frequency dependent components (in the inductance parallel to the crystal and other components in the tank circuit) to produce resonance at the desired frequency. Some of the benefits of this design include the use of two voltage regulators as opposed to one for increased stability. For the implementation of this circuit, polystyrene capacitors were chosen as opposed to ceramic disk capacitors for better frequency performance.

Analyzing the circuit further, it was established that the Barkhausen Criterion for the feedback loop was satisfied. The Barkhausen Criterion states that the total loop gain must be slightly greater than 1, and the net phase shift must be equal to zero for the desired frequency. In this case, the loop gain was approximately 1.5 and the overall phase shift was -0.2 degrees. A diagram of the circuit used in the MTU design appears in figure 6.2.

L_2 is used to offset the crystal’s internal shunt capacitance of 1 pF and to produce resonance at 69.5 MHz so that the crystal appears as an overall resistance of 60 Ω . The equivalent model is contained in figure 6.2

which explains the crystal’s electrical behavior. It is a hand wound toroidal inductor of 5.25 μH with a ferrite core. L_1 , part of the tank circuit, is used to tune the gain of the oscillator at the desired frequency. It is a hand wound air-core inductor with a value of 0.1875 μH . C_1 is also part of the tank circuit. It is a variable ruby-piston capacitor which is also used to tune the tank circuit with a range of 1-10pF. C_4 and C_5 are fixed-value capacitors, 18 pF and 56 pF respectively, which are also part of the tank circuit. R_2 is the final tank circuit component with a value of 1 k Ω .

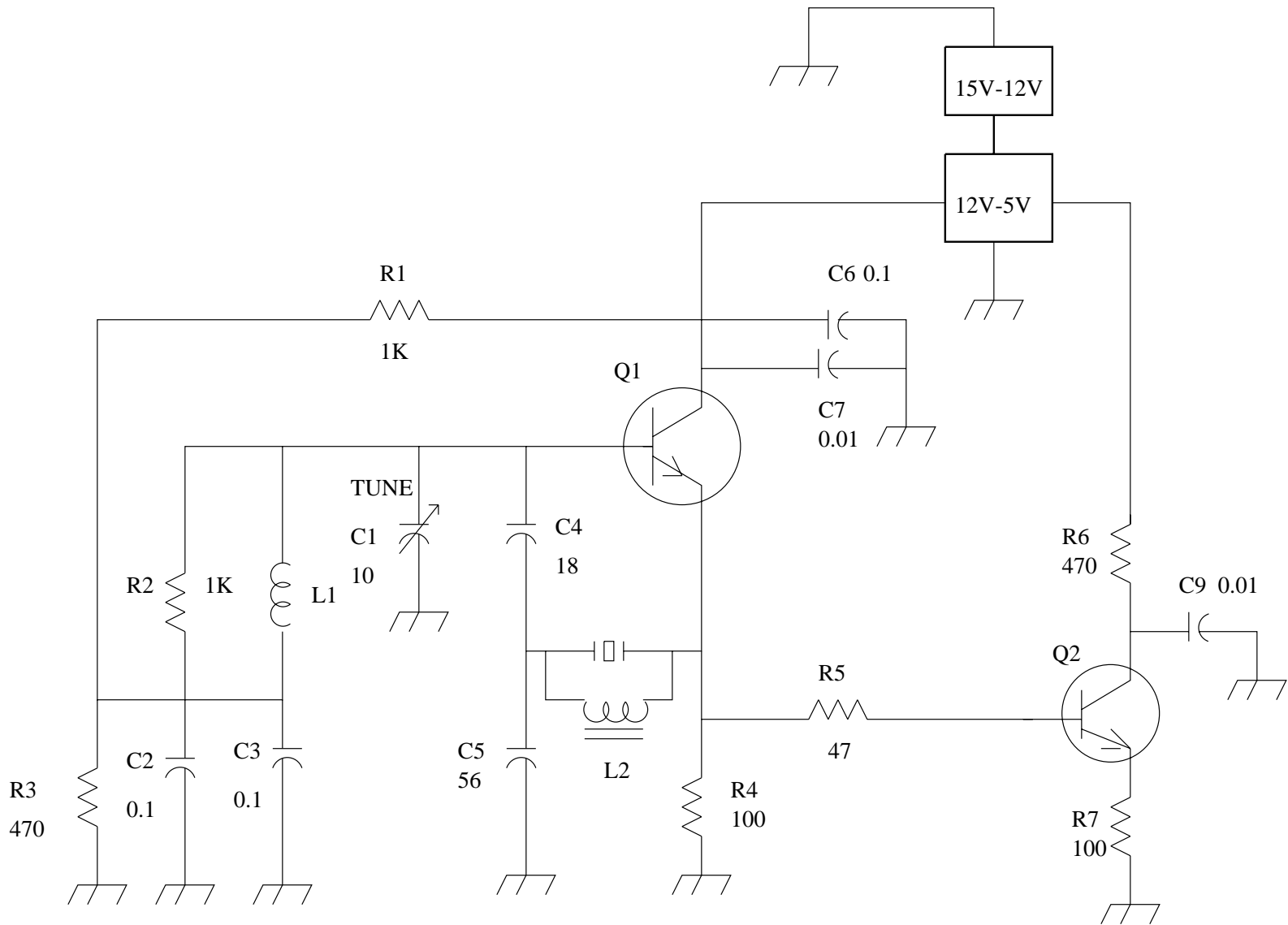
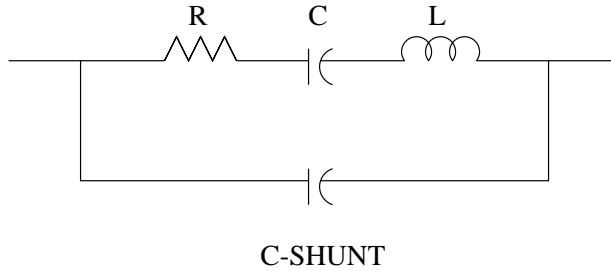

Figure 6.1: Oscillator design.



EQUIVALENT CIRCUIT MODEL FOR A GENERAL CRYSTAL

Figure 6.2: Equivalent network for the crystal.

The oscillator is powered by a 15 volt DC supply which is reduced to 5 volts via two voltage regulators. It is designed to produce an output amplitude of 10 dBm which is coupled to the frequency multiplier stage of the receiver.

6.3 Testing

Upon initial testing of the oscillator, unexpected problems were encountered. Instead of the two clean spikes in the vicinity of 69.5 MHz on the spectrum analyzer, a large number of harmonics were discovered from DC to approximately 35 MHz. Tuning of the variable capacitor to clean up the output was attempted. However, the capacitor was slightly below the desired range as required for resonance in the tank circuit. To compensate for this condition, variable inductors were implemented in an attempt to offset the lack of capacitance. However, the inductors were of poor mechanical quality and fell apart the first time during tuning. Next, the original inferior variable capacitor was replaced with a higher quality ruby-piston capacitor which was in the exact range the design specifications called for. However, this was once again to no avail as a large assortment of harmonics appeared across the output terminals, ranging from DC to about 40 MHz.

Subsequently, the original transistors were replaced with new RF MPS5179 transistors, which are typically used in low noise microwave oscillators and amplifiers, to eliminate the possibility that the original static sensitive transistors were damaged. However, this did not work as the original “bugs” in the oscillator appeared to still be alive and well. Further consideration of the situation suggested that the problem remained in the poor quality inductors. To remedy this, the originals were removed and replaced by hand wound inductors. The inductance values were measured on a Fluke impedance meter. Another test of the oscillator revealed the exact same problems as before.

6.4 Conclusions

After exhaustively applying all angles of approach and troubleshooting techniques to remedy this problem, a viable solution has not been reached. However, the quality of the crystal used is questionable. The current crystal is a solder tin can package as opposed to being assembled under 5 atmospheres of vacuum and sealed using cold welding like a **U.S. Crystal** type would. It is also accurate out to only 4 decimal places as opposed to the required 6 decimal places of accuracy needed for the receiver. Finally, in comparing crystals, the current crystal has a higher frequency drift over time and varying temperature which can be close to 100 PPM as opposed to only a few PPM in a higher quality **U.S. crystal**.

Chapter 7

Frequency Multiplier

7.1 Introduction

The primary objective of this design is to create a circuit capable of accepting an input sinusoidal signal of 69.5 MHz with a power level of +11 (± 2 dBm) and generates an output of 347.5 MHz. In other words, this circuit is essentially a 5x (times 5) frequency multiplier.

7.2 Design

The basic structure of the design includes a harmonic generator followed by a cascade of two amplifiers and finally a band pass filter with a center frequency of 347.5 MHz and a bandwidth of 40 MHz as shown in Figure 2.

7.2.1 Harmonic Generator

The input from the local oscillator is 69.5 MHz and for mixing purposes, a 347.5 MHz signal is desired. To achieve this goal, the harmonic generator shown in Figure 7.1 is used. Each of the capacitors has a value of 10pF. This design is taken from Dr. Richard Campbell's publication "A Clean, Low-Cost Microwave Local Oscillator" [2].

The following equations are used to build the inductor of Figure 7.2 for the harmonic generator in Figure 7.1 [3].

$$\omega = \frac{1}{\sqrt{LC}} \quad (7.1)$$

$$L = \frac{d^2 n^2}{18d + 40nd_{wire}} \quad (7.2)$$

7.2.2 Amplifiers

The amplification stage of the circuit consists of 50 Ω monolithic amplifiers. Two amplifiers were used in cascade with a rated gain of approximately 25 dB each. Figure 7.3 shows the biasing configuration of the amplifier [8].

It should be noted that C_{block} and R_{bias} have values of 10 pF and 1.2 k Ω , respectively. Furthermore, a DC supply of +15V is used to energize the amplifiers.

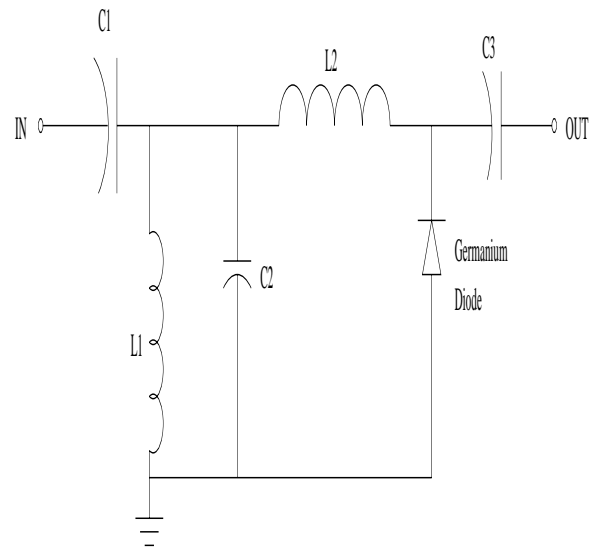
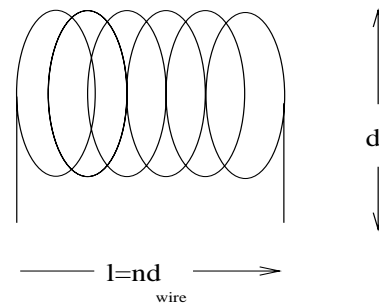

Figure 7.1: Harmonic generator circuit.



n =number of turns
 (all dimensions in inches)

Figure 7.2: Inductor

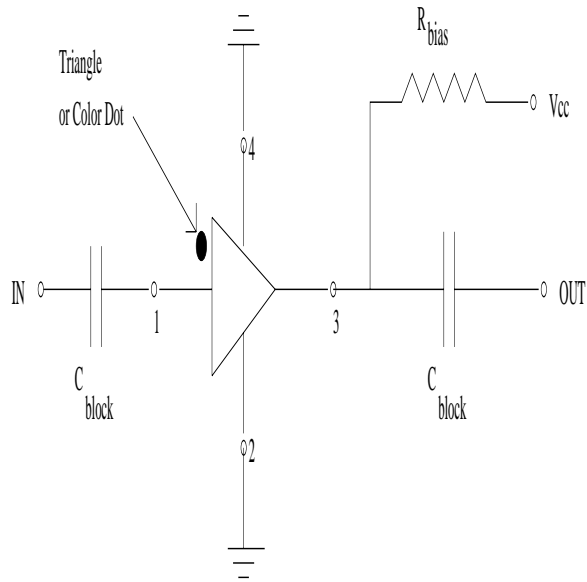

Figure 7.3: Amplifier biasing circuit

7.2.3 Filter

The filtering of the unwanted harmonics is accomplished by using a hairpin filter. This type of filter was chosen because of the available resources. Super Star Professional Version 5.3 was used to design the filter with a center frequency 347.5 MHz and a bandwidth of 40MHz.

7.3 Testing Results

7.3.1 Harmonic Generator

In theory, the designed harmonic generator, if tuned correctly, should generate odd harmonics of the input signal and in this case, the fifth harmonic is desired. However, the harmonic generator in this design failed to create the harmonics as the results of the experiments indicate. Further research about harmonic generator design should be considered.

7.3.2 Amplifiers

The theoretical gain of the cascaded amplifiers is 50 dB. The overall measured gain of the circuit is found to be 20 dB. It is our speculation that the harmonic generator and the filter combine to give approximately 30 dB of attenuation.

7.3.3 Filter

The frequency spectrum of the filter was observed and the highest peak appeared at the desired center frequency of 347.5MHz. Harmonics of this center frequency were also observed. The input signal to the filter consisted of a number of harmonics at extraneous frequencies which were reduced or eliminated after filtering. The attenuation of the filter was found to be 10 ± 2 dB.

7.4 Conclusion

The circuit did not perform as expected due to the harmonic generator not operating properly, but the remainder of the circuit functioned well. With further investigation into the workings of the harmonic generator, the circuit can be made to function properly.

Bibliography

- [1] Pavo M. Anthony, Vendelin D. George, and Rohde L. Ulrich. *Microwave Circuit Design Using Linear and Nonlinear Techniques*. John Wiley and Sons Inc., New York, 1990.
- [2] Dr. Richard L. Campbell. A clean low-cost microwave local oscillator. *QST*, July, 1989.
- [3] The American Radio Relay League Inc. *The ARRL Handbook for Radio Amateurs*. 1995.
- [4] Ali Khatzibadeh, Michael L. McMahan, and Pradeep Shah. *Wireless Systems and Technology Overview*. Texas Instruments, Dallas, Texas, 1994.
- [5] John David Kraus. *Radio Astronomy*. Cygnus-Quasar Books, 2nd edition, 1986.
- [6] John Miller. *Circuit Fabrication and Layout Using Eagle 2.6*. Internal Communications, Fall, 1994.
- [7] Mini-Circuits. *RF/IF Designer's Handbook, 1992-1993*. Mini-Circuits Division of Scientific Components, 1992.
- [8] Mini-Circuits. *RF/IF Designer's Handbook, 1996-1997*. Mini-Circuits Division of Scientific Components, 1996.
- [9] Eagle 2.6 Schematic. *Layout and Autorouter Manual*. Cadsoft Computer Inc., 1992.