

Power Efficient Gathering in Sensor Information Systems based on Ant Colony Optimization (ACO) in WSN

Patwant Singh,
M.Tech Student,
GNDU REC, Gurdaspur

Satbir Singh
Assistant Professor
GNDU REC, Gurdaspur

Abstract: Wireless Sensor Network has the major constraint of energy resources while they are encountered in the real time applications. Numerous routing techniques have been developed to achieve the maximum network lifetime. Data collection has always been the concerning in terms of the routes being followed for sending data to the Base Station. PEGASIS (Power Efficient Gathering in Sensor Information Systems) is one of the impactful chain based protocol which follows the chain topology to collect data and forwarding it to the next node till it reaches to the Base Station. This protocol proves its significance in the small area network. Leader node selection is one of the areas where PEGASIS finds its scope for improving the network lifetime. Various optimization techniques which are naturally inspired helps in finding out the optimized path to reduce the energy consumption. Here in this paper, Ant Colony Optimization Technique (ACO) has been used. ACO helps in finding out the optimized routes for data transmission. Simulation results show that with used of ACO optimized technique, FND (First Node Dead) is found to be increased by 15% and LND (Last Node Dead) is enhanced by 6 %

Keywords: Ant Colony Optimization; PEGASIS; Wireless Sensor Network (WSN), FND (First node dead); LND (Last node dead).

I. INTRODUCTION

Due to recent technological advances in microelectromechanical systems (MEMS), the manufacturing of small, low-cost, low power and multifunctional sensors has become technically and economically feasible. These sensors are deployed in order to achieve high quality network [1-2]. These sensors measure ambient conditions in the environment surrounding them such as temperature, movement, sound, light, or the presence of certain objects, inventory control, and disaster management and then transform these measurements into signals that can be processed to reveal some characteristics about phenomena located in the area around these sensors [3]. In the recent years WSNs has emerged as an important technology for monitoring physical environment [4].

These WSNs can be used in wide range of applications such as Military surveillance, environment monitoring, space exploration, disaster relief, health care monitoring, weather monitoring. Deployment of a sensor network in these applications can be in random fashion (e.g., dropped from an airplane in a disaster management application) or

manual (e.g., fire alarm sensors in a facility or sensors planted underground for precision agriculture). Creating a network of these sensors can assist rescue operations by locating survivors, identifying risky areas, and making the rescue team more aware of the overall situation in a disaster area [5].

A. Architecture of Wireless Sensor Network

WSN's architecture consists of various nodes being deployed in the network, with sink positioned outside or inside the network depending upon the application. From sink, the collected data is sent to user via internet shown in Figure 1.

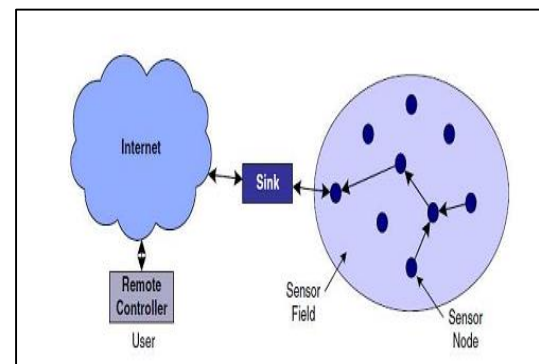

Figure1 Architecture of WSN

These architecture are entirely based on the topology of the application for which sensor network is being used. There may be multiple data collecting platforms assigned the task of data collection.

B. Architecture of Sensor Node

Each sensor node consists of four main components. They are sensing unit, transmission, processing unit and power source. Some sensor nodes also consist of optional components like position finding system (GPS), power generator and mobilizer. The sensing unit generally consists of sensor and Analogue and digital converter (ADC) [6].

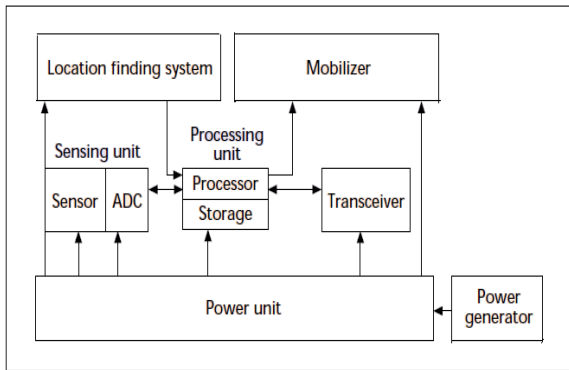

Figure 2 Components of Sensor Node

C. Routing in Wireless Sensor Network

One of the main design goals of WSNs is to carry out data communication while trying to prolong the lifetime of the network and prevent connectivity degradation by employing aggressive energy management techniques. The design of routing protocols in WSNs is influenced by many challenging factors. Among various hierarchical routing protocols the PEGASIS has been considered in this paper. The study of various routing protocols being covered in [7]

PEGASIS (Power Efficient Gathering in Sensor Information Systems):

Wireless sensor nodes sense data and send it directly to the base station or they perform a clustering procedure as in LEACH [8]. The key idea in using PEGASIS is that it uses all the nodes to transmit or receive with its closest neighbor nodes. This is achieved by the formation of a chain as shown in the Figure 3 below. All the nodes which collect the data fuse it with the data received by the neighbor node and transmit it to the next-nearest neighbor. In this way all the nodes receive and fuse their data, and pass it to the next neighbor in a chain format till they all reach the base station. Every node in the network takes turns as a leader of the chain and the one responsible to transmit the whole fused data collected by the chain of nodes to the base station.

The rest of paper is organized as Section 2 covers related work, section 3 covers the problem definition & proposed work, results and simulation is covered in section 4. Conclusion in covered is given in section 5 along with listing the references.

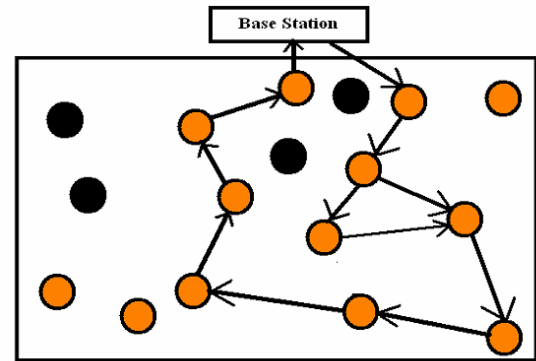

Figure 3 PEGASIS Chain Based Protocol

II. RELATED WORK

Wang Linping in [8] has proposed an enhanced algorithm of PEGASIS which balances the load on each node and improves the network lifetime. In PEGASIS, there is only one cluster head in each chain whereas in PDCH i.e. PEGASIS Double Cluster Head, there are double cluster heads which avoids the long chain problem existing in PEGASIS. Zibouda in [9] has proposed a new protocol i.e. PEGASIS-MH in order to minimize the consumption of energy and to enhance the life time of sensor network. PEGASIS-MH protocol is developed for multi-hopping within the sensing field. In [10] Feng proposed an algorithm to build chain, and uses weighting method when selecting the leader node, that is assigning each node a weight so as to represent its appropriate level of being a leader. Vibha Nehra in [11] proposed an algorithm by using average distance among the sensor nodes as the criteria for chaining and thereby providing better performance in terms of energy dissipation and amount of information sent to BS. The chaining speed of proposed method is faster than PEGASIS. This algorithm avoids the formation of LL and provides a stable and balanced lifetime to the network. Madhuri Gupta in [12] proposed a variant approach for chain formation in the wireless sensor network which is a modified version of chain based PEGASIS protocol. In this paper, the process of forming chain is modified in order to obtain a chain with multiple degree nodes. This approach considered degree of connectivity and remaining energy of each node. It achieved the target of the improvement in energy consumption and prolong the lifetime of the network. Simulations results achieved 50% better results in average energy consumption by the network under defined scenario.

III. PROBLEM DEFINITION & PROPOSED WORK

The energy optimization minimizes the use of that material by minimizing the amount of batteries and other materials that used in wireless sensor networks over the time. Also, the cost of sensors, power and batteries represent a big problem for all users and manufacturers. From that, the problem of energy optimization in wireless sensor networks is important case for the modern researchers, and taken into place for all manufacturers

and developers of such systems. Whereas, the main issue of this problem from computer systems and information technology side is the chain formation of the wireless sensors network. By developing a good new hierarchal routing algorithm of the network, it can save more energy the original PEGASIS Protocol.

The wireless sensor depends on its battery to run along its life time, thus, the life time depends on the consumption of the power. The consumption of power is directly proportional to the routing technique being followed. PEGASIS is an efficient chain based protocol which seeks optimization in the routing technique that it follows. There have been various optimization methods in among which ACO has been significant to optimize routing path. So this work is focused to analyze the ACO implementation in PEGASIS protocol.

IV. RESULT & SIMULATION FOR ACO BASED PEGASIS

In order to implement PEGASIS routing protocol the network model has to be framed at the first level. Network Model described below gives the detail of scenario in which the sensor network is made to work. The dimensions of field are 100 X 100 m² with 100 numbers of nodes being deployed randomly but uniformly in the network. These nodes are homogeneous in nature and consist of 0.5 Joules of energy. The task of data collection is performed by sink which is placed at (50,175) location which is outside the network. The size of data packets is 2000 bits and data aggregation consumes 5nJ energy.

These simulation parameters are directly dependent on the application for which these sensor network is deployed.

Table 1: Simulation parameters used in proposed protocol

Parameters	Value
Network size	100×100m ²
Number of nodes	100
Base station	(50,175)
Initial energy of node	0.5J
E_{elec}	50 n J/bit
E_{fs}	100 p J/bit/m ²
E_{mp}	0.0013 p J/bit/m ⁴
Data packet	2000 bits
E_{DA}	5 n J/bit

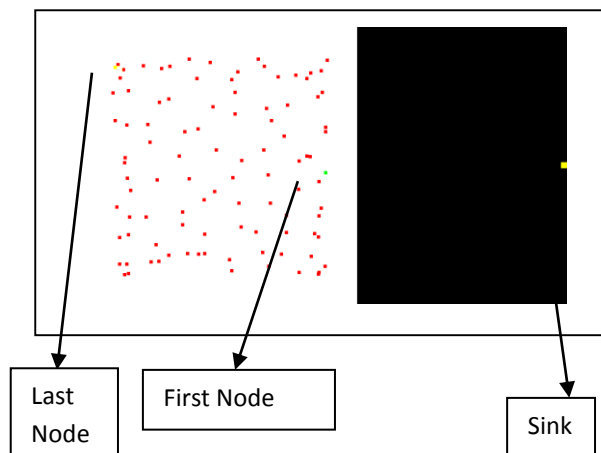

Figure 4 simulating scenario of network

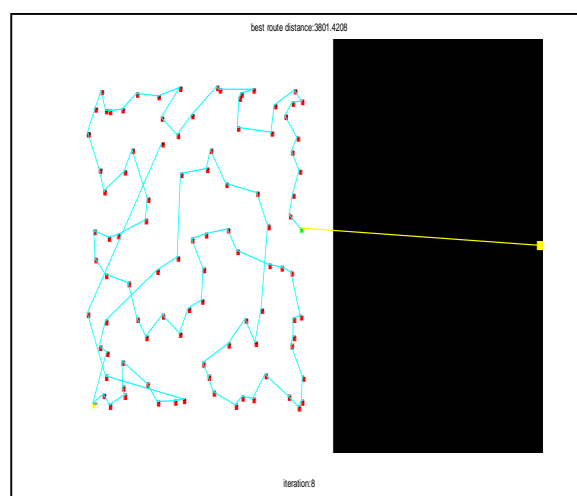

Figure 5 Data transmission in the network

In Figure 4 the network is shown after being simulated in the MATLAB. First Node which is the nearest to the Base Station, last node which is the farthest is being selected. In Figure 5 the data transmission phase starts and a chain is formed in the network. This chain makes the data transmission much more convenient.

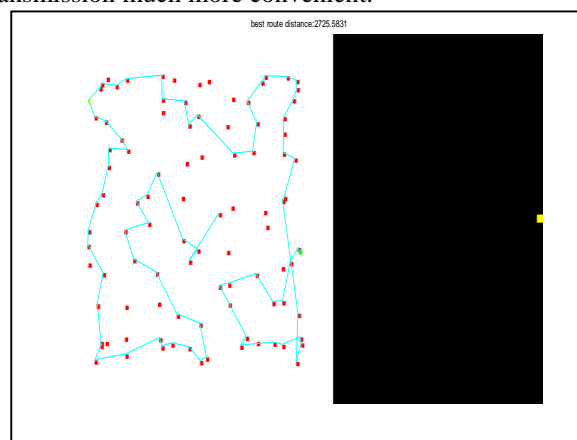

Figure 6 Scenario of network with 25% node dead

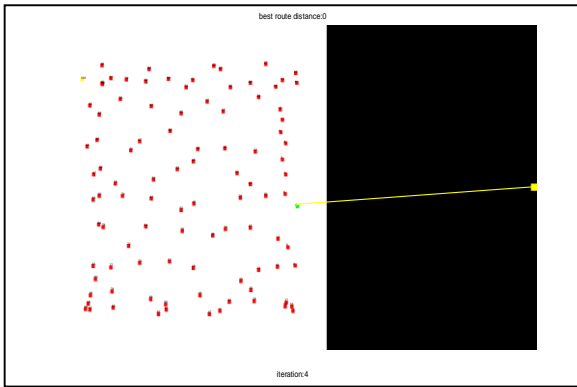

Figure 7 Scenario of network with all nodes dead

In Figure 6 after completion of some rounds 25 % node dead is being shown. After almost 2800 rounds all nodes are dead being shown in Figure.7. 25% nodes dead signifies that among 100 nodes which were considered initially for the data collection task, among them only 75 nodes are having some energy so are able to transmit some data, rest 25 nodes have depleted their energy at the maximum and are considered to be dead. This is one of the significant feature which accounts for the network lifetime. In Figure 8 the results of proposed technique is being validated with the standard PEGASIS and M-PEGASIS. It is being found that proposed protocol achieves 15% improvement in the First Node Dead and 6 % improvement as compare to the M-PEGASIS protocol. ACO-PEGASIS ensures the optimized data routing which enables the nodes to transmit data in chain for the effective outcomes. As Figure 8 clearly shows the improvement in the enhancement of network lifetime, because the energy of the nodes are effectively managed.

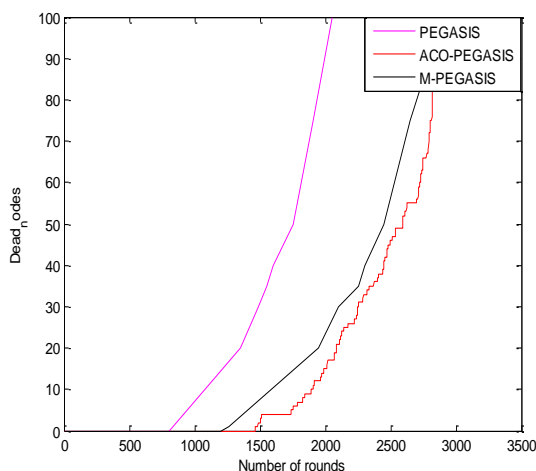

Figure 8 Comparison of Proposed protocol with PEGASIS variants

V. CONCLUSION

Energy efficient hierarchical chain based routing is enhancing the scalability and lifetime of the wireless sensor networks. The simulation of the proposed technique with use of ACO technique on the PEGASIS protocol has been performed in MATLAB 2013 version. Scout bee is the one

who selects the leader node and other bees verifies the path which consumes least energy. It achieves the target of the improvement in energy consumption and prolongs the lifetime of the network. We performed the simulation on MATLAB and achieved 15.6% better results in average energy consumption by the network under defined scenario. The proposed ACO-Based PEGASIS not only enhanced the network lifetime but also gives the optimizing solution for finding out the best route path and best leader selection or data forwarding.

REFERENCES

1. Akyildiz, I.F., W. Su, Y. Sankarasubramanian, E. Cayirci, "A Survey on Sensor Networks", IEEE Communications Magazine, Vol.40, pp.102-114, August 2002.
2. Jamal N, Al-Karaki, Ahmed E Kamal, "Routing techniques in wireless sensor networks: a survey," IEEE journal on Wireless Communication, Vol.11, No.6, pp.6-28, 2004.
3. Kazem Sohrabym Daniel Minoli, Taieb Znati, "Wireless Sensor Networks, Technology, Protocols and Applications", A JohnWiley & Sons, Inc., Publication, 2007.
4. Kemal Akkaya, Mohamed Younis "A survey on routing protocols for wireless sensor networks," IEEE Communication Magazine on Ad Hoc Networks, pp. 325-349, 2005.
5. Shio Kumar Singh 1, M P Singh 2, and D K Singh "Routing protocols in Wireless Sensor Networks –a Survey," International journal of computer science & engineering survey (IJCSSES) Vol.1, No.2, pp. 63-83, 2010.
6. C.W. Reynolds, "Flocks, herds and schools: A distributed behavioral model", In Proceedings of the 14th annual conference on Computer graphics and interactive techniques, ACM Press, pp. 25-34, 1987.
7. Seema Bandyopadhyay and Edward J. Coyle, "An Energy Efficient Hierarchical Clustering Algorithm for Wireless Sensor Networks". IEEE Conference INFOCOM, pp. 189-200, 2003.
8. W.R. Heinzelman, A. Chandrakasan, and H. Balakrishnan, "Energy-efficient Communication Protocol for Wireless Micro sensor Networks", in IEEE Computer Society Proceedings of the Thirty Third Hawaii International Conference on System Sciences (HICSS '00), Washington, DC, USA, Vol. 8, pp. 8020, 2000.
9. Wang Linping, Cai Zhen, "Improved Algorithm of PEGASIS protocol introducing double cluster heads in Wireless Sensor Network", Proceedings of IEEE International Conference on Computer, Mechatronics, Control and Electronic Engineering, pp. 148-151, 2010.
10. Feng Sen, Qi Bing, Tang Liangrui "An Improved Energy-Efficient PEGASIS-Based Protocol in Wireless Sensor Networks," International Conference on Fuzzy Systems and Knowledge Discovery (FSKD), 2011.
11. Zibouda Aliouat, Makhlof Aliouat, "Effective Energy Management in Routing Protocol for Wireless Sensor Networks", IEEE International Conference on New Technologies, Mobility and Security, pp.1-5, 2012.
12. Vibha Nehra, Ajay Kumar Sharma, "PEGASIS-E: Power Efficient Gathering in Sensor Information System Extended," Global Journal of Computer Science and Technology, Vol.13, No.15, pp.1-5, 2013.
13. Madhuri Gupta, Laxmi Saraswat, "Energy Aware Data Collection in Wireless Sensor Network Using Chain Based PEGASIS," IEEE International Conference on Recent Advances and Innovations in Engineering (ICRAIE-2014), pp.1-5, May 09-11, 2014.