

# IJERT

ISSN : 2278-0181

## International Journal of Engineering Research & Technology

Publish & Find Papers @



[www.ijert.org](http://www.ijert.org)



**BROWSE**

OPEN



ACCESS

Call for Papers

# Speed Control of Induction Motor Using Fuzzy Logic Approach

M. Nageswara Rao, A. Rajani

Department of Instrumentation and Control Systems,  
University College of Engineering, JNTU Kakinada, Andhra Pradesh, India.

## Abstract

This paper deals with the stabilization of the induction motor speed very quickly. The Induction motor is modeled using a dq axis theory. The designed Fuzzy Logic Controller's performance is weighed against with that of a PI controller. This paper also presents a methodology for implementation of a rule-based fuzzy logic controller applied to a closed loop Volts/Hz induction motor speed control. For V/f speed control of the induction motor, a reference speed has been used and the control architecture includes some rules. These rules portray a nonchalant relationship between two inputs and an output, all of which are nothing but normalized voltages. The modeled system has been simulated in MATLAB/SIMULINK® and the results have been attached.

**Key Words** – induction motor, Fuzzy logic, volts/Hz control, dq axis theory.

## I. Introduction

The use of induction motors has increased tremendously since the day of its invention. They are being used as actuators in various industrial processes, robotics, house appliances (generally single phase) and other similar applications. The reason for its day by day increasing popularity can be primarily attributed to its robust construction, simplicity in design and cost effectiveness. These have also proved to be more reliable than DC motors. Apart from these advantages, they have some unfavorable features like their time varying and non-linear dynamics.

Speed control is one of the various application imposed constraints for the choice of a motor. Out of all the speed

Control mechanisms, the Volts/Hertz control scheme is very popular because it provides a wide range of speed control with good running and transient performance.

A standard approach for speed control in industrial motors is to use a proportional plus integral (PI) controller. Recent developments in artificial-intelligence-based control have brought into focus a possibility of replacing a PI speed controller with a fuzzy logic (FL) equivalent.

Fuzzy logic speed control is sometimes seen as the ultimate solution for high-performance drives of

the next generation [2]. Such a prediction of future trends is based on comparison of the drive response under PI and FL speed control, which has been compared on a number of occasions.

## II. Dynamic Model Of Induction Motor

The dynamic model of the induction motor is developed by converting the three phase parameters of the motor into the two phase dq stator parameters later on converting into dq rotatory parameters and now by using these dq rotatory voltages we are generate the flux of stator and the flux linkages with rotor (rotor flux equations).By using these relations we are generating a model of induction motor in MATLAB/SIMULINK.

$$\begin{bmatrix} v_{qr}^s \\ v_{dr}^s \\ v_{or}^s \end{bmatrix} = \frac{2}{3} \begin{bmatrix} \cos\theta & \cos(\theta-120^\circ) & \cos(\theta+120^\circ) \\ \sin\theta & \sin(\theta-120^\circ) & \sin(\theta+120^\circ) \\ 0.5 & 0.5 & 0.5 \end{bmatrix} \begin{bmatrix} v_{as} \\ v_{bs} \\ v_{cs} \end{bmatrix}$$

Relation of dq stator parameters with three phases Parameters

$$\begin{bmatrix} v_{as} \\ v_{bs} \\ v_{cs} \end{bmatrix} = \begin{bmatrix} \cos\theta & \sin\theta & 1 \\ \cos(\theta-120^\circ) & \sin(\theta-120^\circ) & 1 \\ \cos(\theta+120^\circ) & \sin(\theta+120^\circ) & 1 \end{bmatrix} \begin{bmatrix} v_{qs}^s \\ v_{ds}^s \\ v_{os}^s \end{bmatrix}$$

Inverse relation

The flux relation with the developed dq stator frame is given as below, where,  $\psi_{qs}^s$  and  $\psi_{ds}^s$  are q-axis and d-axis stator flux linkages, respectively.

$$V_{qs}^s = R_s i_{qs}^s + d\psi_{qs}^s/dt$$

$$V_{ds}^s = R_s i_{ds}^s + d\psi_{ds}^s/dt$$

When these equations are converted to d<sup>e</sup>-q<sup>e</sup> frame, the following equations can be written as below,

$$V_{qs} = R_s i_{qs} + d\psi_{qs}/dt + \omega_e \psi_{ds}$$

$$V_{ds} = R_s i_{ds} + d\psi_{ds}/dt - \omega_e \psi_{qs}$$

$$V_{qr} = R_r i_{qr} + d\psi_{qr}/dt + (\omega_e - \omega_r) \psi_{dr}$$

$$V_{dr} = R_r i_{dr} + d\psi_{dr}/dt - (\omega_e - \omega_r) \psi_{qr}$$

The flux linkage equations in terms of currents can be written as

$$\begin{aligned} \Psi_{qs} &= L_{ls}i_{qs} + L_m(i_{qs} + i_{qr}) & \Psi_{ds} &= L_{ls}i_{ds} + L_m(i_{ds} + i_{dr}) \\ \Psi_{qr} &= L_{lr}i_{qr} + L_m(i_{qs} + i_{qr}) & \Psi_{dr} &= L_{lr}i_{dr} + L_m(i_{ds} + i_{dr}) \\ \Psi_{qm} &= L_m(i_{qs} + i_{qr}) & \Psi_{dm} &= L_m(i_{ds} + i_{dr}) \end{aligned}$$

### III. PI Controller Implementation

The PID algorithm is the most popular feedback controller used within the process industries. It has been successfully used for over 50 years. It is a robust easily understood algorithm that can provide excellent control

Performance despite the varied dynamic characteristics of process plant. As its name indicates it contains proportional, integral and derivative controllers of the feedback term.

The PI controller is having both proportional and integral controllers in the feedback path. The additional integral mode (often referred to as reset) corrects for any offset (error) that may occur between the desired value (set point) and the process output automatically over time. The adjustable parameter to be specified is the integral time of the controller.

The mathematical representation is,

$$\frac{mv(s)}{e(s)} = k_c \left[ 1 + \frac{1}{T_i s} \right] \text{ Or } mv(t) = mv_{ss} + k_c \left[ e(t) + \frac{1}{T_i} \int e(t) dt \right]$$

#### Architecture

In this project we are using the PI controller in the feedback path. By controlling the current we are going to control the speed variation of the motor such that it has to reach the steady state quickly. PI controller is used to control the both amplitude and frequency of the input current to the motor. The actual rotor speed and speed command given to the motor is applied to PI controller.

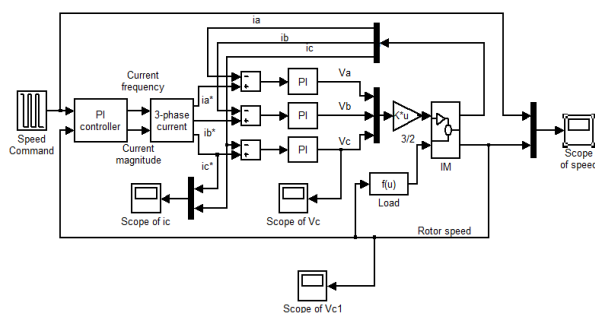

Fig. 1. PI controlled implementation of induction motor.

### IV. Fuzzy Controller Implementation.

The dictionary meaning of the word "fuzzy" is "not clear, indistinct, non coherent, vague". By contrast, in the technical sense, fuzzy systems are precisely defined systems, and fuzzy control is a precisely defined method of non-linear control. The main goal of fuzzy logic is to mimic (and improve on) "human-like" reasoning. "Fuzzy systems are knowledge-based or rule-based systems". Specifically, the key components of fuzzy system's knowledge base are a set of IF-THEN rules obtained from human knowledge and expertise. The fuzzy systems are multi-input-single-output mappings from a real-valued vector to a real-valued scalar.

#### Architecture

The Controller architecture includes some rules which describe the casual relationship between two normalized

input voltages and an output one. These are Error (e), that is speed error, Change-of-error, that is derivative of speed error, and Output, defined as the change-of-control, that added to the motor speed is the input to the converter. These error inputs are processed by linguistic variables, which require to be defined by membership functions.

Here we are using the controller to control the motor speed more accurately than the PI controller. In FUZZY-PI controller PI controller is used to give the control about the change in error. The main control parameter is current, in that the magnitude of the current is controlled according to the change in error. The frequency of the input current is controlled by using the FUZZY controller implementation. So both amplitude and frequency of the motor is controlled according to the change in error.

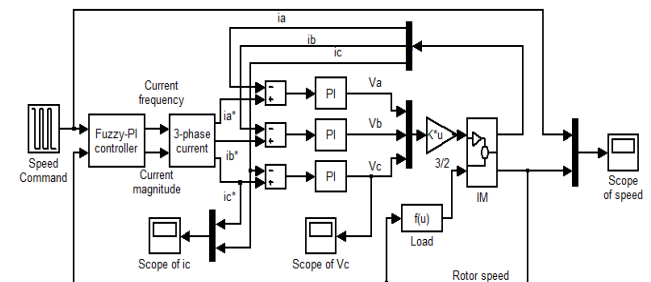

Fig. 2. FUZZY-PI implementation of induction motor.

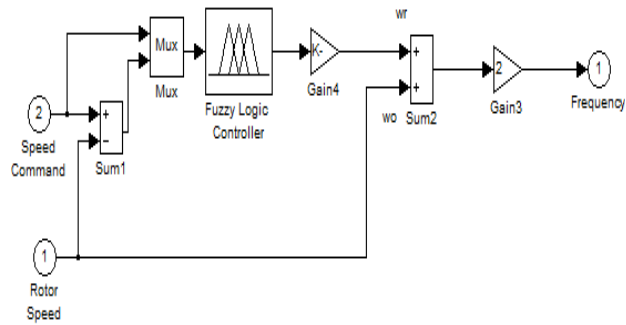

Fig. 3. FUZZY implementation in frequency control.

**V. Simulation Study.**

On simulating the dynamic model of the motor, fixing the initial parameters as frequency (50), stator resistance (0.19), rotor resistance (0.39), stator inductance= $0.21 \cdot \exp(-3)$ , Rotor inductance= $0.6 \cdot \exp(-3)$  Mutual inductance= $4 \cdot \exp(-3)$  and the remaining parameters are stated as same.

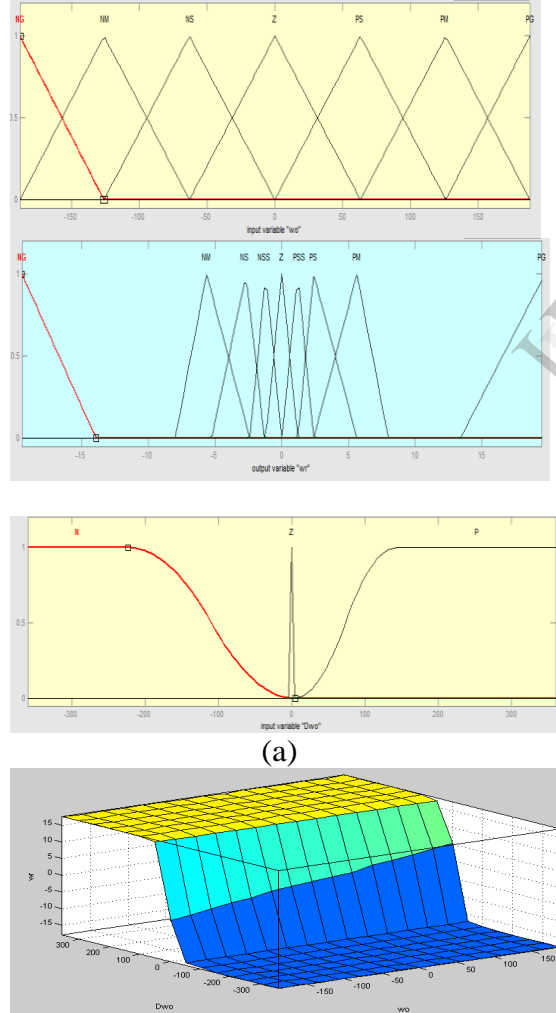

Fig. 4. (a) Membership functions of error, change of error, and output and (b) three-dimensional control surface of the FL speed controller used in simulations.

**VI. Results.**

The response of the controlled induction motor speed for the given speed command for both PI and FUZZY-PI controllers are observed. As below.

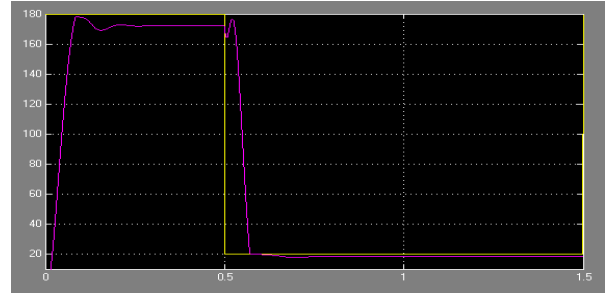

Fig. 5. Response for the PI controller.

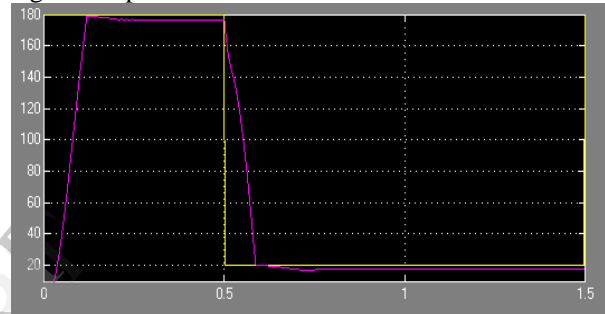

Fig. 6. Response for the FUZZY-PI controller.

**VII. Conclusion.**

From the above results we can say that the control of the induction motor by using the FUZZY implementation is more advantages than the basic PID controllers. Here we are observing the speed controlling ability at lower speed of the motor in the range of below 1000 rpm. Any industrial major need is to control the motor speed at lower speeds.

**VIII. References.**

[1] <http://www.mathworks.com/> (The official site for MATLAB&SIMULINK as well as Fuzzy Logic Toolbox).  
 [2] J. Jantzen, "Tutorial on Fuzzy Logic", Technical University of Denmark: Department of Automation, Technical report number 98-E 868, 19 Aug 1998, URL: <http://www.iau.dtu.dk/>  
 [3] J. Janssen, "Design of Fuzzy Controllers", Technical University of Denmark: Department of Automation, Technical report number 98-E 864, 19 Aug 1998, URL: <http://www.iau.dtu.dk/>  
 [4] C. C. Lee, "Fuzzy Logic in Control Systems: Fuzzy Logic Controller-Part I", IEEE Transactions on Systems, Man, and Cybernetics, Vol. 20, No. 2, pp. 404-418, 1990.

- [5] C. C. Lee, "Fuzzy Logic in Control Systems: Fuzzy Logic Controller-Part II", IEEE Transactions on Systems, Man, and Cybernetics, Vol. 20, No. 2, pp. 419-435, 1990.
- [6] B. C. Kuo, "Automatic Control Systems", Prentice-Hall, 1987.
- [7] K. Ogata, "Modern Control Engineering", Prentice-Hall, 1970.
- [8] Bimal K. Bose, *Modern Power Electronics and AC Drives*, Third impression, INDIA: Pearson Education, Inc., 2007.
- [9] L. Baghli, H. Razik, and A. Rezzoug, "Comparison between fuzzy and classical speed control within a field oriented method for induction motors," in *Proc. EPE'97*, Trondheim, Norway, 1997, pp. 2.444–2.448.
- [10] "Control Tutorial for Matlab: DC Motor Speed Modeling," 1997.

IJERT