

Short Paper

Smart Pigeonhole Alert System with SMS Notification

Taiwo Gabriel Omomule

Department of Computer Science, Adekunle Ajasin University

taiwo.omomule@aaua.edu.ng

(corresponding author)

Sekinat Bolanle Adekile

Department of Computer Science, Adekunle Ajasin University

adekylebolanle@gmail.com

Olusola Olajide Ajayi

Department of Computer Science, Adekunle Ajasin University

olusola.ajayi@aaua.edu.ng

Segun Michael Orimoloye

Department of Computer Science, Adekunle Ajasin University

segun.orimoloye@aaua.edu.ng

Date received: November 21, 2019

Date received in revised form: April 1, 2020

Date accepted: April 7, 2020

Recommended citation:

Omomule, T. G., Adekile, S. B., Ajayi, O. O., & Orimoloye, S. M. (2020). Smart Pigeonhole Alert System with SMS Notification. *International Journal of Computing Sciences Research*, 4(1), 267-287. doi: 10.25147/ijcsr.2017.001.1.38

Abstract

Purpose – Most organizations are outdated in managing information with the use of conventional pigeonholes as message boxes for each member to track staff incoming and outgoing mails. Several challenges are experienced due to loss of relevant mails, untimely delivery and acknowledgement of incoming mails as well as late feedback. This paper proposes a mobile pigeonhole alert system using a sensor device to send an alert to the intended pigeonhole users notifying them of the arrival of a message as well as the need for timely feedback.

Method – Hardware and software implementations were carried out using JAVA programming language to program a sensor, hardcoded on a micro-controller. A well-



structured questionnaire was designed and administered to 200 pigeonhole users (i.e., lecturers) in an academic institution to elicit information about their perception of the usability and performance of the system. The data collected were subjected to statistical analysis using Statistical Package for Social Sciences (SPSS) software for correlation and regression analyses between the usability and system performance.

Results – Statistical results showed that the system performed as expected based on users' satisfaction, realization of system objectives and the significant values obtained from statistical analysis. Comparative analysis of the system also showed an improvement over other existing works.

Conclusion – Information system is an essential aspect of any organization which helps with the dissemination and retrieval of information among members. Hence, the designed system has facilitated the work of office clerks as well as the pigeonhole users by reducing the stress of daily pigeonhole check-in and allows quick feedback mechanism for smooth record and operation to urgent mails.

Practical Implications – An efficient platform for information retrieval and notification has been developed. Users found it convenient to manage memos, letters and other relevant documents without delay and in a timely fashion.

Keywords – alert system, information exchange, messages, performance, pigeonhole, sensor device, usability

INTRODUCTION

The world's economic trends in business require organizations to respond quickly to demand and opportunities through competition and continuous expansion of domestic and international markets and by being innovative as well. This requires organizational members to move beyond and achieve higher frontiers which are achievable only by having the right information (Opoku, 2015). Information plays very important roles in the life of every organization and its identification involves realization of the pivotal roles of information in achieving various organizational goals and strategically plan for it (Opoku, 2015). Therefore, its benefits and management has attracted the attention of industrial practitioners and academics as well. Most organizations manage this information through the implementation of effective information systems across different levels of management. On the other hand, the purpose of an information system is processing, memorizing, and transmitting appropriate information in place, and the best information system is one that performs these functions effectively within little computational cost and time.

All systems including computer systems consist of accepting raw data as inputs, using stored programs for processing the data and producing outputs as timely information. The process of transforming inputs into outputs is known as information management (Shaqiri, 2015) which can be seen in both technical and management perspective (Robertson, 2005). From the technical perspective, information management is seen as managing web content document, records, digital asset, learning systems and enterprise search to improve information need of an organization (Reddy et al., 2009). From management perspective, information management is referred to as managing the organizational, social, cultural and strategic factors to improve information in organizations (Robertson, 2005).

There are various roles of different information systems across several domains of applications in an organization. One of them is *Management Information Systems (MIS)*. MIS are a kind of computer information systems that collect and process information from different sources to assist better decision making across all levels of management. MIS provide information in the form of pre-specified reports and displays to support business decision making (Heidarkhani et al., 2013). One approach which organizations can utilize computing capability is through the development of efficient and effective management information systems. MIS is a system using formalized procedures to provide management at all levels in all functions with appropriate information based on data from both internal and external sources, to enable them to make timely and effective decisions for planning, directing and controlling the activities for which they are responsible. The emphasis of MIS is on the uses to which the information is put. Planning, directing and controlling are the essential ingredients for management (Adeoti-Adekeye, 1997). In essence, the processing of data into information and communicating the resulting information to the user is the key function of MIS. It should therefore be noted that MIS exist in organizations in order to help them achieve objectives, to plan and control their processes and operations, to help deal with uncertainty, and to help in adapting to change or, indeed, initiating change. Management Information System (MIS) is one of the most important tools in any organization, which aims to provide reliable, complete, accessible, and understandable information in a timely manner to the users of the system (Al-Mamary, Shamsuddin, and Aziati, 2014).

MIS is a flow of procedures for data processing based on the computer, and integrated with other procedures in order to provide information in a timely and effective manner to support decision making and other management functions (Bin Haji Sidek, 2010). The authors in (Ensour and Alinizi, 2014) opined that in order for organizations to advance into the future, they must adopt the technology utilization approach, which is a mandatory requirement for such organizations which seek excellence per performance. Moreover, the importance of MIS comes from the benefits that are generated by that system such as providing useful information in a timely manner, improved labor productivity, cost savings, providing information without any delays and mistakes, and improve the management of work (Al-Mamary et al., 2014). One of the effective ways of managing information dissemination and retrieval in an organization is the introduction

of Pigeonhole concept where information in the form of mails is delivered for the perusal and usage of different staff in the organization.

Pigeonhole is an internal information exchange system used for communication in an organization. It is a creative, informal and traditional way of dropping and picking messages in a set of small open-fronted compartments usually used in a workplace or other organizations where letters or messages may be left for individuals. The chain of exchange is a kind of 'give-and-return'. It is a bi-directional 'pick-and-respond' information transmission mode (Ajayi et al., 2018). It can exist in wooden box or metal shelf or take any other form with several rectangular holes in it which is usually been used in offices or large organizations. Pigeonhole works like a letterbox where letter or memo for specific person will be placed in their letterbox in a typical organization or post office. The authors in Ajayi et al. (2018) stated that each staff in most big organizations has his/her own pigeonhole to receive any important letter or memo related to the official duty. Each staff has been allocated a pigeonhole for any letter or memo from within or outside the department, unit or faculty. Unfortunately, the current conventional pigeonhole system is unable to inform the staff on any urgent letter and this leads to significant delay in responding to such message. The main weakness of the current system is that staff needs to check their respective pigeonhole every day but due to the routine commitment or unforeseen circumstances, the pigeonhole cannot be possibly checked every day.

The system proposed by the authors in Ajayi et al. (2018) intends to computerize the traditional way of dropping and picking messages in a set of small open fronted compartments usually used in a workplace or other organization with a two-way communication between the office clerk and the staff via a mobile application. The clerk sends messages via his/her mobile app to the staff notifying them of the availability of memos, letters and other documents in their pigeonhole and the intended staff sends feedback concurrently. Several problems have been identified in this method as untimely delivery and responses to messages, poor feedback, time and effort are wasted in checking up pigeonholes on daily-basis and sometimes clerk's unavailability. Therefore, this paper proposes a pigeonhole alert system using sensor device as an improvement to the stated problems in the work done by Ajayi et al. (2018) to detect the presence of a mail in the pigeonhole with the use of a sensor device and a short messaging system to alert the staff on their mobile phone of the need to pick up their mails.

To back up the submission of this paper, a germane question was raised in form of Research Question.

1.1 Research Question

- i. What association exists between the departments and the idea of using mobile pigeonhole system?

From this research question, the following hypotheses were formulated:

1.2 Research Hypothesis

Hypothesis 1

H₀: There is no significant relationship between the usability perception of the lecturers in the departments and the system performance.

H₁: There is a significant relationship between the usability perception of the lecturers in the department and the system performance.

Hypothesis 2

H₀: There is no significant impact of the designed system (performance) on the department's mail management.

H₁: There is a significant impact of the designed system (performance) on the department's mail management.

LITERATURE REVIEW

Mobile computing has been applied in several pigeonhole platforms in which several researchers have also proposed different techniques and technology to enable timely delivery and access of information across these platforms. A web-based announcement system was developed in Curran and Craig (2001) to provide timely information to students. The system was developed using Java programming language that can deliver a message from web-based interface (electronic form) and sent to a group of students. The system was closely related with Mobile Notice Board project for the delivery of urgent information to students but could not ascertain a feedback module in the deployment.

Mohammad and Norhayati (2003) proposed an SMS service system for student collaboration on campus with focus on quick message communication and delivery among students on campus. Simplewire wireless message protocol and ActiveX SMS software development kit serve as the development tool for visual basic. The system was able to send messages but without mobility. The authors in Al-Ali, Rousan and Al-Shaikh (2003) proposed a system to monitor and control patient body temperature and blood pressure. It was achieved using temperature sensor and signal conditioning circuit, microcontroller, LCD display and GSM modem. The systems contributed immensely to the use of SMS technology for message delivery but were limited by high implementation cost.

Furthermore, Al-Ali et al. (2004) used the same technology to develop a house monitoring system to ease the ordering and delivering of house equipment using SMS technology via mobile phone. The system was developed using C programming language and the hardware and software implementations consist of 8-bit microcontroller interface and driver circuit for connection between device and microcontroller, LCD display and GSM modem. Kadirire (2005) presented a platform where teachers in schools

or presenters at conferences can interact with audience via SMS. The system uses java servlets, a Tomcat Servlet container, an oracle database, HTML and an open source SMS gateway which runs on a UNIX platform. When an SMS message is sent to the SMS gateway using an SMS centre number provided, the servlet running on the Tomcat server receives and creates small frames called stickies that housed the SMS text. Each stickie has a thread that initiates the SMS between the teachers or presenters and the participants.

An SMS technology that supports classroom interaction between students and lecturers is proposed in Markett et al. (2006). The aim was to bridge the communication between lecturers and students in a classroom environment. Students send SMSes via their mobile phone which are viewed, replied and addressed by the lecturers through a developed software connected with a modem. A class website developed was used as the interactive platform between the students and the lecturer after which the SMSes have been published on the website. The system was developed using Java programming language to provide a GUI that models the users' real mobile phone. However, cases of failure in remote connection between the students and lecturers were recorded. An SMS tool to exchange information in medical area is proposed in Obea et al. (2006). The work was developed as a Radiological Information System (RIS) where physician can send messages to their patients. The idea was to configure RIS system to send SMS when the examination is scheduled and to send another SMS later to remind the patient of the appointment. The system offered an easy medium for timely information delivery

In the work of Shahjahan et al. (2008), a vision-based on-line traffic information system is presented to monitor and detect levels of traffic congestion on certain roads in Dhaka City and to make this information available to the travelers. Multiple Web Cams were installed on designated roads. The system captured digital images of the traffic, analyze these images and reach a clear decision about number of cars. Users were able to reach this data by using the short messaging service in their mobile phones. Basically, the system is divided into three independents and interacting modules: the image capturing module which automates the capture of images, the digital image processing module which processes the images and the short message service (SMS) server module which receives SMSs from a user and reply back to him by an SMS.

A GSM-based notification speed detection system for monitoring purposes is presented by Sabudin et al. (2008). The motivation was to improve on the existing black box system that only notifies drivers through alarm systems and information is recorded in the black box in order to detect speed effectively. The system includes both hardware and software designs. The hardware design was carried out using microcontroller, PIC16F873, LCD DISPLAY and GSM Mobile Phone. On the other hand, the speed detector is the programmable equipment designed using the JAL (Just Another Language) software. The design integrates a new black-box system with the GSM notification system to send alert information to traffic authorized personnel or Transport Department through Short Message Services (SMS). An m-banking system using the m-commerce

technology to provide various banking services to the customers by sending SMS in a two-way communication for the banking sector is presented by Jamil and Mousumi (2008). The system consists of five modules: Interfacing Module, SMS Technology Adoption Module, SMS Banking Registration Module, Service Generation Module and Data Failover Module. Four major services such as balance enquiry, balance transfer between authenticated customers, deposit payment and bill payment were provided without physically going to bank thereby saving customers' time. Wahab et al. (2009) developed an integrated e-parcel management system using GSM network. The system notifies user of the upcoming parcel reach in a university via SMS. Their work offered robust platform that enhanced quick message delivery and retrieval that is useful for the day-to-day activities of the university.

In the work of Katankar and Thakare (2010), a Short Message Service using SMS Gateway is proposed. The system suggested a multi-level local authentication to the SMS gateway service. The application and mobile carriers are connected via TCP/IP. SMPP was used as the SMS protocol that is secure and sustain greater message volumes 10,000/min. The software was designed using Visual Basic 2005 while the database connection was written using Query based on SQL. SQL was used to store the record and to retrieve the record. The security of the system was done via a web interface for authentication and an encryption method for securing the data. However, there were inadequacies in messaging functionalities and old encryption algorithm was adopted which is easily vulnerable to brute force attack.

In Ensour and Alinizi (2014), an SMS application system along with its corresponding server is developed. The system was developed to avoid the reliance of content delivery SMS application of student examination results to SMS Gateway Provider and the commercial SMS application developer which can be managed totally by the users. The Rational Unified Process (RUP) was used to iteratively do the system development during each phase. The system promoted SMS technology in school. However, cases of network traffic on the server affect system performance at peak times. A mobile interface for community health information tracking system (CHITS) was developed by Manguni et al. (2010). The system provides cheap and effective remote connection to the CHITS server for synchronizing real time data. The system was developed using JAVA2ME. Data was collected and compressed using the jgz java library with deflate based compression algorithm to minimize the amount of SMS messages to be sent. SMSLib serves as a platform through which a server phone was connected to the server to receive messages through designed protocol that assures availability and reliability. A cost effective way of transferring data remotely with the use of SMS was established but there were limitations in the amount of data that an SMS can carry and manual copying of database file when not using the remote mode.

A framework for the design of a mobile-based alert system for outpatient adherence in Nigeria is proposed in Okuboyejo, Ikhu-Omoregbe and Mbarika (2012). The aim was to ensure adherence to long-term therapy in outpatient condition for effective treatment

and reduce or curb the prevalence of diseases. A system for mobile technology that will provide an easy way of complying with drug regimen was developed. The system utilizes Short Messaging Service (SMS) via mobile phones to provide reminders at dosing times. However, the system was limited by the inability to deploy and evaluate a prototype application within its scope, so the system was not tested.

In Jamaruppin (2014), a pigeonhole notification system using telegram messenger is proposed to help lecturers get notification about the presence of mails in their pigeonholes and to give warning notification when the volumes of their pigeonhole reaches certain level of fullness. The system is a combination of hardware and software that operates together on giving the notification to the pigeonhole owner. The main hardware used was Raspberry Pi while Infra-Red sensor and Ultrasonic sensor were used to detect mails. The main software was telegram messenger while Linux was the operating system to the Raspberry Pi and Python was the language used to command the system. Interview was carried out to get the system requirements and questionnaires were used to collect data in evaluating the performance of the pigeonhole system. Thirty (30) respondents who are lecturers of the institution were randomly sampled. The results from data analysis showed that majority of the respondents chose that the best alternative for mail notification is via SMS.

Krishna, Anurag and Prabhune (2014) proposed a short messaging service as an alternative for pushing information to build efficient information passing systems in academic institutions. The system was targeted at improving existing levels of communication between teachers and students of an academic institution. A total solution architecture was proposed. The architecture consists of a central database server to store and forward requests, a networking interface to send SMS successfully and a client end application to read and acknowledge the SMS. The system was implemented using Open Source API and a middleware where one can build a service wherein students do not have to pay for student information services. The system provides a high degree of security and confidentiality and generates timely information needed in decision support system of the institution. However, there are possibilities for network failure and response of the entire architecture therein. In Norhairi (2015), an intelligent pigeonhole with e-mail notification using wireless system was proposed. The work focuses on incorporating electronics technology into conventional mailboxes as a solution for providing convenient mail notification and retrieval. Arduino UNO and Infrared Sensor were incorporated by linking the user's pigeonhole with e-mail facilities and this enables the users to be notified whenever a new mail is delivered, and pigeonhole is full. The system provides an easy and effective platform for sending e-mail to notify the users about important new mails reaching their pigeonhole or mailbox.

A smart pigeonhole system was proposed through sending notification by short messaging system in Abdullah (2015). The aim was to develop a time-saving system for resident to get a notification about arriving mail via short messaging system on their phone. The system was implemented using several hardware components including

infrared sensors, ultrasonic sensors and arduinoyun board. Infrared sensors were used to detect the presence of the mail into the box while the ultrasonic sensor was used to detect the level of fullness of the mailbox. The system achieved SMS notification for pigeonhole mail arrivals, but the sensor could only be powered by electricity. Cases of power outage followed by subsequent mail arrival would limit the system functionality. Asmida (2015) developed a pigeonhole smart box for university application to assist lecturers who use pigeonhole to receive SMS notification once students drop their assignment in their pigeonhole. Microcontroller Arduino, IR sensor and GSM module were used in building the system. Microcontroller Arduino and GSM module were used for wireless transmission. The installed sensor in the pigeonhole smart box start functioning once it detects the document/assignment received and automatically send an alert signal via SMS notification to the lecturers' cell phone.

Pramanik et al. (2016) also developed a GSM-based Smart home and digital notice board using a GSM SIM900 module that provides its users with a simple, fast and reliable way to put up important notices in an LCD where the users can send a message to be displayed in the LCD. The system consists of a 32-bit ARM based microcontroller LPC2148, GSM SIM900 module, an LCD, a motor and an android application for user interface with the hardware. SMS messages are sent through an android application to the GSM SIM900 module which has a SIM card inside it. However, cases of network failures may significantly affect the system performance. The development of an intelligent pigeonhole using GSM is proposed by Binti Wahab (2016) to notify users when any document arrives inside their pigeonhole using Short Messaging Service (SMS). The basic idea was to monitor software and the main components of the hardware are SIM900A GSM Modem, PIC 16F877A and infrared sensor (IR) system. The implementation utilizes the programming of the control system with Microcontroller PIC16F877A acting as the main process that controls the system when the input gives signal until it produces an output. The system provides a two-way transmission between users and PC16F877A Microcontroller.

Wahab et al. (2016) also developed an electronic pigeonhole system integrated with GSM network to send a notification of any upcoming load. The system was needed to send short message service (SMS) notification to designated users when a new letter is placed in their pigeonhole. A detection circuit that contain voltage regulator, Infrared sensors and microcontrollers to acknowledge the existence of new post items was integrated with a GSM modem to transmit SMS to specific user. The system was attached to a metal pigeonhole and tested. Notifications were immediately sent to intended users for further action. However, the implementation was too costly and there is no possibility of ascertaining good performance of system on wooden pigeonhole platform. Duru, Ochonu and Okoronkwo (2017), proposed a mobile phone controlled wireless electronic notice board that can be used to circulate information in places such as schools, offices, homes and other establishments. The system includes a reliable and an authentic wireless display of SMS on LCD with a mobile phone and microcontroller using GSM Technology. The microcontroller is interfaced to a GSM Modem via MAX233 level converter to convert

RS232 voltage levels to TTL voltage levels and vice versa. A 20x4 LCD display is attached to the microcontroller for display. Microcontroller coding was done using embedded C with the help of Mikro C integrated development environment (IDE). The system offers flexibility and control of information to its users remotely as information is transmitted over a wireless network.

In a similar study, Ajayi et al. (2018) presented a mobile pigeonhole alert system. The authors were motivated to develop a system which allows easy and enhanced communication between the administrator-in-charge of messages (office clerk) and the recipients (academic staff) to ensure proper dissemination of information. The aim was to ensure quick notification, delivery and responses to mail in an academic institution. The system implementation was accomplished using Java and XML components of Android Software Development Kit (SDK). The authors' contribution bridged the gap between the administrator and the user of the pigeonhole by ensuring a feedback mechanism to alert the user of a mail when not attended to. However, the system involves human intervention in which the administrator in charge of the mail would have to send notifications to staff. Also, training is required when there is a change of administrator on how to use the system.

METHODOLOGY

The mathematical model for the proposed system was adopted from the model proposed in Ajayi et al. (2018). The general idea of the pigeonhole principle states that when there are k pigeonholes and there are $k+1$ mails, then there will be 1 pigeonhole with at least 2 mails (Sengothai, 2016). The idea sounds trivial, but its uses are numerous. Thus, this idea is explored to coin a model that supports the implementation of this research. A conventional pigeonhole system consists of one or more pigeonholes for each staff in an institution. Let pgh represents pigeonholes and $stff$, a variable denoting staff:

$$\forall pgh, stff = \{1,2,3 \dots k\} \quad \text{Equation 1}$$

where Equation 1 represent one or more pigeonholes for one or more staff while k is the count number for upper bound value

$$\forall Alt, msg = \{0,1,2,3 \dots n\} \quad \text{Equation 2}$$

where Alt and msg represent alert and message respectively. Equation 2 indicates zero or more alerts for every message available to the staff in his/her pigeonhole. The map function for the pigeonhole process is presented as follows:

$$\forall stff : \exists ! pgh \quad \text{Equation 3}$$

indicating that for each staff, there exist exactly one pigeonhole for message delivery

$$\forall \text{stff} : \exists \text{msg} \quad \text{Equation 4}$$

Equation 4 denotes that any staff can have one or many messages.

$$\forall \text{msg} : \exists \text{Alt} \quad \text{Equation 5}$$

Equation 5 denotes that there exist one or many alerts for each message received in the staff pigeonhole. In equation 6, when an alert is not received on the staff mobile phone, then no message is received. A message is only received when one or many alerts are confirmed on the phone.

$$\text{Alt} = \begin{cases} 0, & \exists \text{msg} \\ 1, n & \exists \text{msg} \end{cases} \quad \text{Equation 6}$$

$$R = \begin{cases} 1, & \exists \text{msg} : \forall \text{pgh} \\ 0, & \exists \text{msg} : \forall \text{pgh} \end{cases} \quad \text{Equation 7}$$

In equation 7, *R* indicates the staff response to the message available in their pigeonhole. When the staff responds to the received message, then no new message is found in the pigeonhole. Otherwise, when no response is received, one or more messages are left in the pigeonhole unanswered.

3.1 Circuit Diagram

The circuit diagram of the proposed system is presented in Figure 1 as follows:

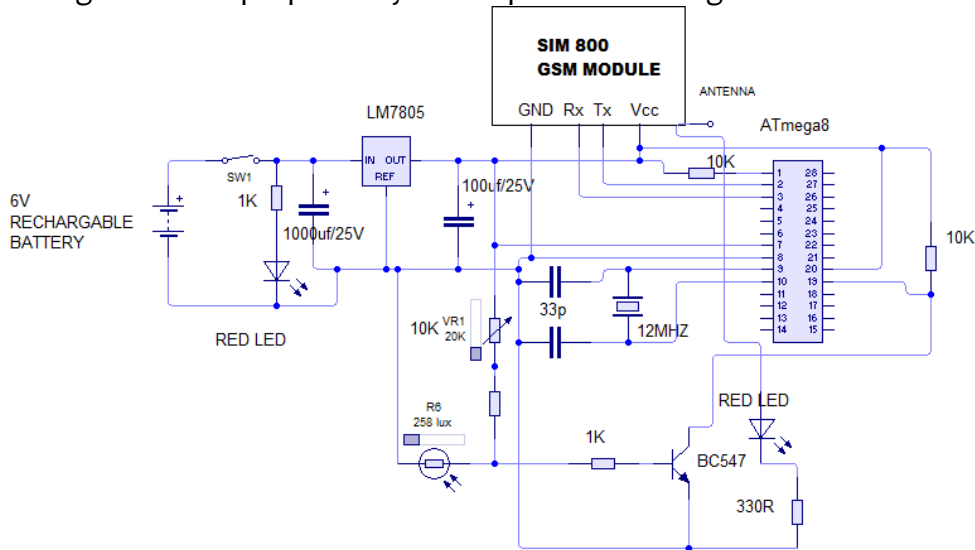

Figure 1. Circuit diagram of the proposed system

This pigeonhole circuit sends a message to the user about the arrival of a mail. The circuit is powered by a rechargeable battery of 6volt. Once the system is powered, a high bright white light comes up from the Light Emitting Resistor (LER) which is used to trigger the Light Dependent Resistor (LDR) to detect the arrival of a mail in the box. The sensor then sends a signal to the micro-controller which is ATmega8. The micro-controller

then sends a signal to the GSM-Module on the arrival of a mail. The GSM-module uses SIM 800 module that is designed as a data communication equipment. It comprises of the ground (GND), the receive data (Rx) which is an input device, the transmit data (Tx) which is an output device and an antenna to detect network signal. Once the micro-controller sends a signal to the GSM-module, the Tx sends a message to the user whose number is registered on the SIM module for a mail arrival in the pigeonhole. The capacitors are used to regulate the frequency of the circuit. When the light from the LER fails to come up, the LDR will become non-conducting and the presence of a mail will not be detected.

3.2 Sensor Module

The sensor module consists of several hardware components that work together to ensure the smooth running of the system. Figure 2 shows the sensor module as follows:



Figure 2. Sensor Module

The components housed in the sensor module include Switch, Battery, Light Emitting Diode, Light Dependent Diode (LDD), GSM Module, Micro-controller, Capacitor, and Transistor:

3.3 Pigeonhole Interface

The actual pigeonhole implementation is carried out on both wooden and metal platform for testing.

a. Wooden Pigeonhole Implementation

Figure 3 shows the implementation of the sensor module using a wooden pigeonhole.



Figure 3. wooden pigeonhole implementation

b. **Metal Pigeonhole Implementation**

Figure 4 shows the implementation of the sensor module using metal pigeonhole.



Figure 4. Metal pigeonhole

3.4 Statistical Treatment of Data

In this research, data were collected by questionnaire administration to respondents in order to infer a significant relationship between the independent and dependent variables. These data were further subjected to statistical analysis using Correlation and Regression Analyses respectively.

3.4.1 Correlation Analysis

Correlation analysis assesses the linear relationship between two variables, providing a measure of both the strength and direction of the relationship. Correlation makes no assumption on causality in the relationship. It assumes only a linear relationship, and variables with a strong nonlinear relationship may show poor or absent correlation. Correlation can be performed on both parametric and nonparametric variables. The most commonly used parametric method is the Pearson product-moment correlation which is adopted in this research while Spearman rank order correlation and Kendall methods are the commonly used nonparametric methods. In certain situations, the correlation relationship can be linear to a certain extent beyond which it may disappear or remain linear but at a different degree (Shi and Conrad, 2009).

3.4.2 Regression Analysis

Regression analysis assesses the relationship between one dependent (observed) variable and 1 or more independent and (explanatory) variables, with an implied causal relationship. Regression goes beyond correlation by inferring relationships between variables, allowing modelling of causal relationships, and predicting the value of the dependent variable from a given value of independent variables(s). Unlike correlation analysis, which makes few assumptions, regression analysis is based on several underlying assumptions. Regression analysis includes both linear and nonlinear regression. Linear regression involves a linear model, which is linear with respect to its parameters. Linear regression models may be simple (a single independent variable) or

multiple (two or more independent variables). Non-linear regression deals with exponential, power, or more complex relationships (Shi and Conrad, 2009).

Thus, the independent variable is the perception of the lecturers across various departments. These perceptions are the factors that constitute their views about the designed system while the system performance serves as the dependent variable. In this case, the independent variable is the computed value for the performance of the system. The computed value denotes the perception or view of the respondent (lecturers) who answered the questions about the systems performance during system testing. Thus, the average success rate (ASR) and average failure rate (AFR) of the designed system are presented in Equations 8 and 9 respectively:

$$ASR = \sum_{k=1}^n \frac{\text{total successful delivery}}{n} \text{ where } n = \text{number of lecturers} \quad \text{Equation 8}$$

$$AFR = \sum_{j=1}^m \frac{\text{total failed delivery}}{m} \text{ where } m = \text{number of lecturers} \quad \text{Equation 9}$$

RESULT AND DISCUSSION

The system was tested on both wooden and metal pigeonhole platforms and a structured questionnaire was developed and administered to two hundred (200) lecturers across nine (9) departments of the faculty of Science of a tertiary institution to elicit information about respondents' perception and system performance during testing. The data collected are presented in Table 1 and the graphical representation is shown in Figure 5 as follows:

Table 1. Data Collection

Departments	No of SMS Sent	Successful Delivery	Failed Delivery	% of Success Rate	% of Failure Rate
Computer science	24	23	1	95.8	4.2
Physics and electronics	21	18	3	85.7	14.3
Plant Science & Biotech	27	25	2	92.5	7.5
Microbiology	17	17	0	100	0
Biochemistry	25	23	2	92.0	8.0
Mathematics/Ind. Math	20	17	3	85.0	15.0
Animal & Env. Biology	22	21	1	95.5	4.5
Chemical Science	26	24	2	92.3	7.7
Earth Sciences	18	17	1	94.4	5.6
TOTAL	200	185	15	833.2	66.8

From the data presented in Table 1, the ASR and AFR values are presented as follow:

$$ASR = \frac{185}{200} * 100 = 92.5\% \quad AFR = \frac{15}{200} * 100 = 7.5\%$$

The average success rate of the system under testing was 92.5% while the system failed with an average failure rate of 7.5%. This was attributed to cases of network failures in which messages were not timely delivered on the respondent's mobile phone. However, the analysis of result was carried out using regression analysis of respondents' perception about system performance as presented in section 4.1 as follows:

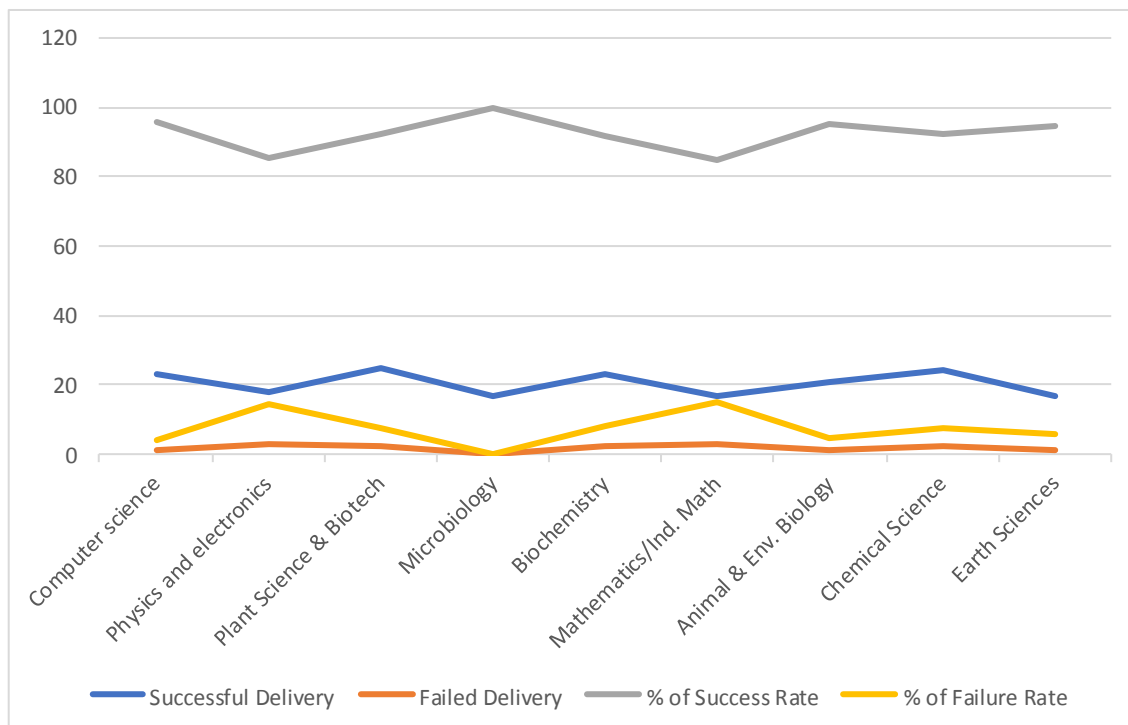

Figure 5. Success and Failure Rates of Messages sent by the various Departments

4.1 Analysis of Result

With respect to Research Question 1, Table 2 shows the descriptive statistics of the given data. It shows the relationship between the central tendency (mean) and the variability (standard deviation). The result shows that over half of the selected respondents agree on the idea of the designed system.

Table 2. Descriptive Statistics

	Mean	Std. Deviation	N
system_testing	2.3827	.29829	200
Department	5.0000	2.55841	200

Analyzing Research Hypothesis 1, Table 3 shows the correlation between the departments. The Pearson correlation coefficient shows a positive correlation between the usability perception of the lecturer's across various departments and the performance of the designed system because there was no negative value in the result.

Table 3. Correlation Measure

		System testing	Department
Pearson Correlation	system_testing	1.000	.774
	Department	.774	1.000
Sig. (1-tailed)	system_testing	.	.000
	Department	.000	.
N	system_testing	200	200
	Department	200	200

For the Research Hypothesis 2, Table 4a shows the regression coefficients that describe the significant relationship between the independent variable and the dependent variable. Therefore, the p-value of 0.013 was used to determine the significance of the system testing. Since the p-value is lesser than 0.05, then there is a significant association between the lecturers' usability perception and the system performance. Hence, the objectives of the system were achieved. However, if the value is greater than 0.05, it means the system did not meet the expected objectives.

Table 4a. Regression Coefficients

Model	Unstandardized Coefficients		Standardized Coefficients	t	Sig.
	B	Std. Error	Beta		
(Constant)	1.931	.063		30.633	.013
department	.090	.011	.774	8.024	.000

a. Dependent Variable: system_testing

Table 4b shows the model summary. It is shown that the R Square is 89%, which means that more than almost all the lecturers from each of the departments are in support of the designed system.

Table 4b. Model Summary

Model	R	R Square	Adjusted Square	R	Std. Error of the Estimate
	.774 ^a	.890	.590		.19094

b. Predictors: (Constant), department

Table 4c. ANOVA^a

Model	R	Df	Mean Square	F	Sig.
1 Regression	2.347	1	2.347	64.380	.026 ^b
Residual	1.568	43	.036		
Total	3.915	44			

a. Dependent Variable: system_testing

b. Predictors: (Constant), department

Table 4c shows the significant of the model. Since the significant value on the table is 0.026, it shows that the system model is significant since the value is lesser than 0.05.

4.2 Comparative Analysis

Table 5 shows the comparative analysis of this work with other existing works. The results derived showed that our system is efficiently analyzed and effectively implemented. Hence, it is an evidence for improvement on other existing results in the reported studies.

Table 5. Comparison of current work with the result of the existing works

Author	Sensor	Messaging Mode	Platform	Programming language	Pigeonhole
Mohammad and Norhayati (2003)	Not used	SMS	Software	VB	None
Markett et al. (2005)	Not used	SMS	Software	JAVA	None
Bin Hajj Sidek (2010)	Not	SMS	Software	Rational Unified Process	None
Manguni et al. (2010)	Not used	SMS	Software	JAVA	None
Krishna et al. (2014)	Not used	SMS	Software	DBMS	None
Abdullah (2015)	Infrared/ Ultrasonic	SMS	Hardware	C++	Metal
Wahab et al. (2016)	IR /LED	SMS	Software	None	Metal
Ajayi et al. (2018)	Not used	SMS	Software	JAVA	Wooden
Current Research	LED/LDD	SMS	Hardware/ Software	JAVA	Wooden/ Metal

CONCLUSION AND RECOMMENDATION

Information system is an essential aspect of any organization which helps with the dissemination and retrieval of information among members. Study shows that most institutional organizations make use of pigeonhole as a message box for each member of such organization. An organization increasingly adopts information technology to move their operations and services to a new level by embracing information systems to ease information dissemination within the organization. Hence, the designed system has been able to ease the work of office clerks as well as the pigeonhole users by reducing the stress of daily pigeonhole check-in and allow quick feedback mechanism for smooth record and operation to urgent mails. It is recommended to organizations for their data processing, file administration and management. However, the work can be improved by estimating the levels of resistance, frequency, wavelength, voltage, and power dissipation of the LER that will enhance the output of the LDR in detection. This will undoubtedly enhance the coverage level of the sensor-based system.

IMPLICATIONS

Practically, the research has contributed significantly by providing an easy platform and efficiency in information retrieval and notification. Users found it convenient in managing memos, letters and other relevant documents without delay and in a timely fashion. Theoretically, the research has also contributed to the existing body of knowledge in the application of mobile computing and sensors in management and organization.

ACKNOWLEDGEMENT

The author acknowledges the contributions of the co-authors in data collection and practical analysis of results. The research has not been funded by any institution rather funding was provided by the author and co-authors.

REFERENCES

- Abdullah, N. B. (2015). *Smart pigeonhole system by sending notification through short messaging system* (Unpublished manuscript). Faculty of Computer Systems and Software Engineering, Universiti Malaysia Pahang, Malaysia.
- Adeoti-Adekeye, W. B. (1997). The importance of management information systems. *Library Review, MCB University Press, 46*(5), 318-327.
- Ajayi, O. O., Adetuyi, T. E., Omomule, T. G., Orogun, A. O., & Orimoloye, S. M. (2018). Design and implementation of mobile Pigeon-Hole Alert System (PHAS). *Communications on Applied Electronics (CAE), 7*(16), 10-16.

- Al-Ali, A. R., Al-Rousan, M., & Al-Shaikh, M. (2003, June). Embedded system-based mobile patient monitoring device. In *16th IEEE Symposium Computer-Based Medical Systems, 2003. Proceedings.* (pp. 355-360). IEEE.
- Al-Ali, A. R., Rousan, M. A., & Mohandes, M. (2004, April). GSM-based wireless home appliances monitoring & control system. In *Proceedings. 2004 International Conference on Information and Communication Technologies: From Theory to Applications, 2004.* (pp. 237-238). IEEE.
- Al-Mamary, Y. H., Shamsuddin, A., & Aziati, N. (2014). The role of different types of information systems in business organizations: A review. *International Journal of Research (IJR)*, 1(7), 1279-1286
- Asmida, A. (2015). *Pigeonhole smart box for university application: A project report submitted at the Universiti Teknikal Malaysia Melaka (UTeM), Malaysia.* Retrieved from www.eprints.utm.edu.my
- Bin Haji Sidek, S. F. (2010). The development of the Short Messaging Service (SMS) Application for the School Usage. *Proceedings from 2010 International Symposium on Information Technology System. Development and Application and Knowledge Society, ITSIM'10(3)*.1382–1386. doi: 10.1109/ITSIM.2010.5561647
- Binti Wahab, N. S. (2016). Development of intelligent pigeonHole using GSM. Technical Report submitted to the Department of Electronic Engineering Technology (Telecommunication) *Universiti Teknikal Malaysia Melaka (UTeM)*, 1-45. Retrieved from <http://eprints.utm.edu.my/20378/>
- Curran, K., & Craig, R. (2001). A Short Message Service Online Application for Delivering Urgent Information to Students 1st Joint IEI. In *IEE Symposium on Telecommunications Systems Research.*
- Duru, C., Ochonu R., & Okoronkwo C. O. (2017). Design and implementation of a wireless noticeboard with interface for remote update. *International Journal of Scientific & Engineering Research*, 8(5), 530-535.
- Ensour, H. S., & Alinizi, T. M. (2014). The impact of management information systems (mis) technologies on the quality of services provided at the University of Tabuk. *International Journal of Network Security & Its Applications (IJNSA)*, 6(2), 1-20. doi:10.5121/ijnsa.2014.6201
- Heidarkhani, A., khomami, A. A., Jahanbazi, Q., & Alipoor, H. (2013). the role of management information systems (mis) in decision-making and problems of its implementation. *Universal Journal of Management and Social Sciences*, 3(3), 78–89.
- Jamaruppin, M. E. (2014). *Pigeonhole notification system by utilizing telegram messenger* (Unpublished manuscript). Faculty of Computer Systems and Software Engineering, Universiti Malaysia Pahang, Malaysia. Retrieved from <http://iportal.ump.edu.my/lib/item?id=chamo:92007>
- Jamil, M. S., & Mousumi, F. A. (2008, December). Short messaging service (SMS) based m-banking system in context of Bangladesh. In *2008 11th International Conference on Computer and Information Technology* (pp. 599-604). IEEE.
- Kadirire, J. (2005). The Short Message Service (SMS) for schools/conferences. *Recent Research Developments in Learning Technologies*, 977-981. Retrieved from <http://www.formatex.org/micte2006/>

- Katankar, V. K., & Thakare, V. M. (2010). Short Message Service using SMS gateway. *International Journal on Computer Science and Engineering (IJCSE)*, 2(4), 1487-1491.
- Krishna, V., Anurag, R., & Prabhune, S.S. (2014). *Short Messaging Service as an alternative for pushing information to build efficient information passing systems in academic institutions*. Paper presented at the 2014 Conference on IT in Business, Industry and Government: An International Conference by CSI on Big Data, CSIBIG2014, India. doi: 10.1109/CSIBIG.2014.7057006
- Manguni, R., Navarro, M. L., Rosario, K., & Festin, C. A. (2010). ChitSMS: Community Health Information Tracking System Using Short Message Service. *3rd International Conference on Human-Centric Computing, 2010*, 1-6. doi:10.1109/HUMANCOM.2010.5563329
- Markett, C., Sanchez, I. A., Weber, S., & Tangney, B. (2006). Please turn ur mobile on: Short Message Services (SMS) Supporting Interactivity in the Classroom. *Computers and Education*, 46(2006), 280-293. doi:10.1016/j.compedu.2005.11.014
- Mohammad, M. A., & Norhayati, A. (2003, January). A short message service for campus wide information delivery. In *4th National Conference of Telecommunication Technology, 2003. NCTT 2003 Proceedings*. (pp. 216-221). IEEE. doi:10.1109/tcst.2003.1188339
- Norhairi, A. H. (2015). *Intelligent pigeonhole with e-mail notification using wireless system* (Unpublished manuscript). Universiti Teknikal, Melaka, Malaysia.
- Obea, J. V., Pardo, I., Villa, I., Masoliver, E., Boix, X., Lopez, A., Andujar, S., & Fernandez, J. (2006). *SMS: A new tool in the radiological information system information exchange*. EuroPACS, Trondheim.
- Okuboyejo, S. R., Ikhu-Omoregbe, N. A., & Mbarika, V. W. (2012). A framework for the design of a mobile-based alert system for outpatient adherence in Nigeria. *African Journal of Computing & ICT*, 5(5), 154-161.
- Opoku, M. O. (2015). Information management and organisational performance: A review of literature. *Mediterranean Journal of Social Sciences*, 6(6), 62-70
- Pramanik, A., Rishikesh, Nagar, V., Dwivedi, S., & Choudhury, B. (2016). GSM based Smart Home and Digital Notice Board. In *2016 International Conference on Computational Techniques in Information and Communication Technologies (ICCTICT)*. doi: 10.1109/ICCTICT.2016.7514549
- Reddy, G. S., Srinivasu, R., Rikkula, S. R. & Rao, V. S. (2009). Management information systems to help managers for providing decision making in an organization. *International Journal of Reviews in Computing*, 5(1), 1-6.
- Robertson, J. (2005). *10 Principles of Effective Information Management*. Step Two Design Pty Limited.
- Sabudin, E. N. MohdMuji, S. Z., Wahab, M. H. A., Johari, A., & Bin Ghani, N. (2008). GSM-based notification speed detection for monitoring purposes. In *2008 International Symposium on Information Technology*. doi:10.1109/itsim.2008.4631934
- Sengothai, R. (2016). Generalized pigeonhole principle and its applications. *International Journal on Recent and Innovation Trends in Computing and Communication (IJRITCC)*, 4(11), 19 – 21.

- Shahjahan, M. D., Kafi M., Nahin, M., Mayen U., Shamim A., & Murase, K. (2008). An Implementation of on-line traffic information system via Short Message Service (SMS) for Bangladesh. *IEEE International Joint Conference on Neural Networks (IJCNN)* (pp. 2612-2618). doi:10.1109/ijcnn.2008.4634163
- Shaqiri, B. A. (2015). Management information system and competitive advantage. *Mediterranean Journal of Social Sciences*, 6(1), 204-208. doi:10.5901/mjss.2015.v6n1p204
- Shi, R., & Conrad, S. A. (2009). Correlation and regression analysis. *Annals of Allergy, Asthma & Immunology*, 103(4), 35-41. doi:10.1016/s1081-1206(10)60820-4
- Wahab, M. H. A., Al' Hafiz Riman, A., Kadir, H. A., Sanudin, R., Johari, A., Sidek, R. M., & Ahmad, N. (2016). GSM-Based Notification System for Electronic PigeonHole. *International Conference on Networked Digital Technologies (NDT) 2010: Networked Digital Technologies, Part II, CCIS 88* (pp. 619-630).
- Wahab, M. H. A., Nor, D. M., Mutalib, A. A., Johari, A., & Sanudin, R. (2009). Development of Integrated e-parcel Management System through GSM Network. In *2nd International Conference on Interaction Science 2009* (pp. 2-6). doi: 10.1145/1655925.1656121