

**Review Article****A review on recent innovation in osmotically controlled drug delivery system**

Neetu R. Gupta*, Aditee Mishal, Yogesh Bhosle, Supriya Shetty

*Oriental College of Pharmacy, Plot No.3,4,5,Sector-2 Near Sanpada Rly Station,Sanpada, Navi Mumbai, India***ARTICLE INFO:****Article history:**

Received: 16 April 2014

Received in revised form:

29 April 2014

Accepted: 5 May 2014

Available online: 15 June 2014

Keywords:Osmotic pumps, Osmosis,
Zero-order,
Semipermeable membrane,
Osmotic agent.**ABSTRACT**

In recent years, oral controlled release (CR) system is most acceptable dosage form by the patients. Drugs having short biological half-life and poor water solubility are the suitable candidate for development of CR system. They include dosage forms for oral and transdermal administration as well as injectable and implantable systems. For most of drugs, oral route remains as the most acceptable route of administration. Certain molecules may have low oral bioavailability because of solubility or permeability limitations. Development of an extended release dosage form also requires reasonable absorption throughout the gastro-intestinal tract (GIT). Among the available techniques to improve the bioavailability of these drugs fabrication of osmotic drug delivery system is the most appropriate one. The release of drug(s) from osmotic systems follows zero order. It is mainly governed by various formulation factors such as solubility and osmotic pressure of the core component(s), size of the delivery orifice, and nature of the rate-controlling membrane. The present review highlights an overview of OCDDS. And new technologies, fabrication and recent clinical research in osmotic drug delivery. Further, the challenges of these technologies and its future perspective are also discussed at length.

Introduction

Novel drug delivery systems (NDDS) are the key area of pharmaceutical research and development. The reason is relatively low development cost and time required for introducing a NDDS (\$20-50 million and 3-4 years, respectively) as compared to new chemical entity (approximately \$500 million and 10-12 years, respectively). The focus in NDDS includes design of NDDS for new drugs on one hand and on the other NDDS for established drugs to enhance commercial viability [1]. During the past three decades significant advances have been made in the area of NDDS. Among the various NDDS available in market, controlled drug delivery system has taken major role in the pharmaceutical development. This is due to improved patient convenience and compliance, reduction in fluctuation in steady state plasma level so decrease intensity of local or systematic side effects and increase safety margin of high potency drugs. In control release (CR) systems, there is maximum utilization of drug enabling reduction in total amount of dose administered and possibility of delivering

drugs having short biological half-life[2]. Various designs are available to control or modulate the drug release from a dosage forms. Majority of oral CR dosage forms fall in the category of matrix, reservoir or osmotic systems. Conventional matrix or reservoir type formulations exhibits problem of bioavailability fluctuations due to gastric pH variations. Moreover, the release of drugs from these systems is affected by the hydrodynamic conditions of the body. Osmotically controlled drug delivery systems (OCDDS) is one of the most promising drug delivery technologies that use osmotic pressure as a driving force for controlled delivery of active agents[3]. Drug release from OCDDS is independent of pH and hydrodynamic conditions of the body because of the semi permeable nature of the rate-controlling membrane and the design of deliver orifice used in osmotic systems, so a high degree of *in vitro/in vivo* correlation is achieved. It is also possible to obtain higher release rates through these systems than through other diffusion-based systems [4,5]. There are over 240 patented osmotic drug delivery systems. They are

also known as GITS (gastro-intestinal therapeutic system) [6] and today, different types of osmotic pumps, of various drugs, are available in the market to fulfil patient's need and requirement [7,8]. This review mainly focuses on the theoretical aspects, basic components of OCDDS, factors affecting OCDDS, different technologies, marketed products and future asp.

Advantages

The following advantages have contributed to the popularity of osmotic drug delivery systems [9,10].

- The delivery rate of zero order is achievable with osmotic system.
- Delivery may be delayed or pulsed, if desired.
- Higher release rates are possible with osmotic system compared with conventional diffusion-controlled delivery system.
- The release rate of osmotic system is highly predictable.
- For oral osmotic system, drug release is independent to gastric pH and hydrodynamic condition.
- The release from osmotic system is minimally affected by presence of food in gastrointestinal tract.
- A high degree of *in vivo-in vitro* correlation is obtained in osmotic system.
- Improve patient compliance with reduced frequency.

Basic Concepts

Principle of Osmosis

Osmosis can be defined as the spontaneous movement of a solvent from a solution of lower solute concentration to a solution of higher solute concentration through an ideal semi permeable membrane, which is permeable only to the solvent but impermeable to the solute. The pressure applied to the higher-concentration side to inhibit solvent flow is called the osmotic pressure [11].

Delivery Rate

The OCDDS consists of an osmotic core containing drug and an osmogen surrounded by a semi permeable membrane with an aperture. A system with constant internal volume delivers a volume of saturated solution equal to the volume of solvent uptake in any given time interval. Excess solids present inside a system ensure a constant delivery rate of solute. The rate of delivery generally follows zero-order kinetics and declines after the solute concentration falls below saturation [12]. The solute delivery rate from the system is controlled by solvent influx through the semi permeable membrane. The osmotic flow of the liquid depends on the osmotic and hydrostatic pressure differences across the semi permeable membrane of the system. This phenomenon is the basic feature of no equilibrium thermodynamics, which describes the volume flux across the semi permeable membrane [13].

Formulation Considerations of OCDDS

Generally OCDDS consists of two parts: One of this is core and another is semi permeable membrane (coating). Core of OCDDS consists of drugs, osmotic agents, hydrophilic and hydrophobic polymers, flux regulating agents, wicking agents, while coating includes polymer, coating solvent, plasticizers and pore forming.

Basic Components Required for Osmotic Pump

- a) Drug
- b) Osmotic agent
- c) Semi permeable membrane
- d) Channelling agent or pore forming agent
- e) Flux regulator
- f) Wicking agent
- g) Coating solvent
- h) Plasticizer

a. Criteria for selection of a drug

- Short biological half life (2-6 hour)
- High potency
- Required for prolonged treatment (e.g. nifedipine, verapamil, glipizide, chlorpromazine hydrochloride.)

Vyas.P. *et al* (2004) developed an oral osmotic system which can deliver theophylline and salbutamol sulphate simultaneously for extended period of time and characterized it. An optimized system was selected to study the effect of concentration of pore forming agents and orifice diameter on the release of the drugs. The release profiles of both drugs were satisfactory when compared with marketed controlled release formulations [14].

Roger A. Rajewski *et al* (2004) investigated the application of controlled-porosity osmotic pump tablet (OPT) utilizing (SBE)7m --CD both as a solubilizer and an osmotic agent for drugs with varying physical properties. OPTs utilizing (SBE)7m--CD were prepared for five poorly soluble drugs such as prednisolone, estradiol, naproxen, indomethacin and chlorpromazine and for two highly water soluble drugs such as diltiazem hydrochloride and salbutamol sulfate. It was found that for the soluble drugs (SBE)7m --CD acts primarily as an osmotic and an OPT control agent. Significantly, (SBE)7m --CD not only enhances the delivery of poorly soluble drugs from OPTs but acts as controlling excipients for soluble drugs such that the release rate, corrected for tablet surface area, of both poorly soluble and soluble drugs are similar [15].

Roger A. Rajewski *et al* (1999) studied the membrane controlling factors responsible for drug release from a controlled-porosity osmotic pump tablet (OPT) that utilizes sulfobutyl ether--cyclodextrin, (SBE) 7m --CD, both as solubilizing agent and osmotic agent. The release rate of chlorpromazine (CLP) from OPTs containing (SBE) 7m --CD increased with increasing amounts of micronized lactose and decreasing amounts of triethyl citrate. The effect of lactose particle size in the membrane on drug release was studied [16].

b. Osmotic agent

Polymeric osmogents are mainly used in the fabrication of osmotically controlled drug delivery systems and other modified devices for controlled release of relatively insoluble drugs. Osmotic pressures for concentrated solution of soluble solutes commonly used in controlled release formulations are extremely high, ranging from 30 atm for sodium phosphate up to 500 atm for a lactose-fructose mixture (table 1). These osmotic pressures can produce high water flows across semi permeable membranes [17]. The osmotic water flow across a membrane is given by the equation,

$$dv/dt = A Q \Delta \theta \Pi / l$$

Where dv/dt , is the rate of water flow across the membrane of area A , thickness l , permeability θ in $\text{cm}^3.\text{cm}/\text{cm}^2. \text{h. atm}$, and $\Delta\pi$ [18].

Wright *et al.*, (1992) studied an osmotic controlled release bilayer tablet for water soluble drugs. In their device, the drug compartment containing the drug and an osmo polymer, a low molecular weight CMC (as thixotropic transport means), was placed together side by side with the osmotic compartment which had a higher molecular weight CMC as osmotic agent preferably with another osmotically active compound. Both low and high molecular weight CMC in the device cooperated to exhibit a high level of hydrodynamic and osmotic activity adequate for controlled delivery of the drug over the time with minimum (as little as 3.7%) residual drug left in the device [19].

c. Semi permeable membrane

The membrane should be stable to both outside and inside environments of the device. The membrane must be sufficiently rigid so as to retain its dimensional integrity during the operational lifetime of the device. The membrane should also be relatively impermeable to the contents of dispenser so that osmogen is not lost by diffusion across the membrane. Finally, the membrane must be biocompatible. Some good examples for polymeric materials that form membranes are cellulose esters like cellulose acetate, cellulose acetate butyrate, cellulose triacetate, ethyl cellulose and Eudragits [20].

Ideal properties of semi permeable membrane [21]

The semi permeable membrane must meet some performance criteria,

a. The material must possess sufficient wet strength (10-5 psi) and wet modulus so (10-5 psi) as to retain its dimensional integrity during the operational lifetime of device.

b. The membrane must exhibit sufficient water permeability so as to attain water flux rates (dv/dt) in the desired range. The water vapour transmission rate can be used to estimate water flux rate.

c. The reflection co-efficient (θ) or "leakiness" of the osmotic agent should approach the limiting value of unity. But polymer membrane must be more permeable to water.

Hai Bang Lee *et al* (2000) studied the sandwiched osmotic tablet system (SOTS). A sandwiched osmotic tablet core surrounded by a cellulose acetate membrane with two orifices on the surfaces of both sides was successfully prepared for the purpose of delivering nifedipine. The appropriate orifice size was observed in the range of 0.50 – 1.41 mm. It was also found that the drug release rate of SOTS could be increased by incorporating hydrophilic plasticizer in the membrane, whereas it could be decreased by incorporating a hydrophobic plasticizer [22].

Herbig S. M. *et al* (1995) found a new type of asymmetric membrane tablet coatings offering significant advantages over conventional osmotic tablets. These asymmetric-membrane coatings can be used to make osmotic drug-delivery formulations with several unique characteristics. The use of asymmetric-membrane coatings on pharmaceutical tablets is

described in this study; the coatings have also been applied to capsules and multi-particulate formulations [23].

d. Channeling agent or leachable pore forming agents

These are the water-soluble components which play an important role in the controlled drug delivery systems. When the dissolution medium comes into contact with the semipermeable membrane it dissolves the channeling agent and forms pores on the semipermeable barrier. Then the dissolution fluid enters the osmotic system and releases the drug in a controlled manner over a long period of time by the process of osmosis. Some examples of channeling agents are polyethylene glycol (PEG) 1450, -mannitol, bovine serum albumin (BSA), diethylphthalate, dibutylphthalate and sorbitol [24-26].

Pradeep Vavia. R *et al* (2003) designed a controlled porosity osmotic pump based on controlled release systems of pseudoephedrine in which cellulose acetate was used as a semipermeable membrane. The effect of pH on drug release was also studied. This system was found to deliver pseudoephedrine at a zero order rate for twelve (12) hrs independent of the environmental pH [27].

Ji-Eon Kim *et al* (2000) studied the effect of various pore formers on the controlled release of an antibacterial agent from a polymeric device. Cefadroxil was chosen as the model antibiotic and was incorporated into a polyurethane matrix by the solvent casting method. Polyethylene glycol 1450 or -mannitol, or bovine serum albumin (BSA) was used as a pore former. The morphological changes in the matrices before and after release studies were investigated by scanning electron microscopy (SEM). Changing the weight fraction and particle size of the pore formers/drug mixtures could control the release of cefadroxil from the matrix. The release rate of cefadroxil increased as the loading dose of the pore former increased (15<20<25%) [28].

Gaylen Z M. *et al* (1985) studied zero-order release of water-soluble osmotically active agents from tablets coated with controlled porosity walls. The walls were sponge like in appearance and substantially permeable to both water and dissolved solutes. The rate of release was a function of the wall thickness and the level of leachable pore forming agents. The concept of osmotically actuated drug delivery on an equivalent mass per unit surface area basis was demonstrated [29]

e. Flux regulators

Delivery systems can be designed to regulate the permeability of the fluid by incorporating flux regulating agents in the layer. Hydrophilic substances such as polyethylene glycols (300 to 6000 Da), polyhydric alcohols, polyalkylene glycols, and the like improve the flux, whereas hydrophobic materials such as phthalates substituted with an alkyl or alkoxy (e.g., diethyl phthalate or dimethoxyethylphthalate) tend to decrease the flux. Insoluble salts or insoluble oxides, which are substantially water-impermeable materials, also can be used for this purpose [30].

f. Wicking agents

A wicking agent is defined as a material with the ability to draw water into the porous network of a delivery device. A

wicking agent is of either swellable or non swellable nature. They were characterized by having the ability to undergo physisorption with water. Physisorption is a form of absorption in which the solvent molecules can loosely adhere to surfaces of the wicking agent via Vander Waals interactions between the surface of the wicking agent and the adsorbed molecule. The function of the wicking agent is to carry water to surfaces inside the core of the tablet, thereby creating channels or a network of increased surface area. Materials, which suitably for act as wicking agents include colloidal silicon dioxide, kaolin, titanium dioxide, alumina, niacinamide, sodium lauryl sulphate (SLS), low molecular weight poly vinyl pyrrolidone (PVP), mpyrol, bentonite, magnesium aluminium silicate, polyester and polyethylene.

g. Coating solvent

Solvents suitable for making polymeric solution that is used for manufacturing the wall of the osmotic device include inert inorganic and organic solvents that do not adversely harm the core, wall and other materials. The typical solvents include methylene chloride, acetone, methanol, ethanol, isopropyl alcohol, butyl alcohol, ethyl acetate, cyclohexane, carbon tetrachloride, water etc. The mixtures of solvents such as acetone-methanol (80:20), acetone-ethanol (80:20), acetone-water (90:10), methylene chloridemethanol (79:21), methylene chloridemethanol- water (75:22:3) etc. can be used[18].

h. Plasticizer

Different types and amount of plasticizers used in coating membrane also have a significant importance in the formulation of osmotic systems. They can change viscoelastic behavior of polymers and these changes may affect the permeability of the polymeric films [30]. Some of the plasticizers used are as below:

- Polyethylene glycols
- Ethylene glycol monoacetate; and diacetate for low permeability
- Tri ethyl citrate
- Diethyl tartarate or Diacetin- for more permeable film

Factors influencing the design of osmotic controlled drug delivery systems Drug Solubility

For the osmotic system, solubility of drug is one of the most important parameters affecting drug release kinetics from osmotic pumps. The kinetics of osmotic drug release is directly related to the drug solubility within the drug core. Assuming a tablet core of pure drug, the fraction of core released with zero-order kinetics is given by equation [31].

$F(z) = 1 - S/\rho$ (1) Where, $F(z)$ is the fraction released by zero-order kinetics, S is the drug's solubility (g/cm^3), and ρ is the density (g/cm^3) of the core tablet. Drugs with a density of unity and the solubility of $\leq 0.05 \text{ g}/\text{cm}^3$ would be released with $\geq 95\%$ zero-order kinetics, according to Eq. (1). At the same time, highly water-soluble drugs would demonstrate a high release rate that would be zero-order for a small percentage of the initial drug load. Thus, the intrinsic water solubility of many drugs might prohibit them from incorporation into an osmotic pump[32]. Candidate drugs for osmotic delivery have water solubility in the range 50–300 mg/ml. Some of the approaches that have been used to modulate drug solubility within the core include:

- (1) co-compression of the drug with excipients, which modulate the drug's solubility within the core[33-39].
- (2) use of effervescent mixtures to speed up the release of poorly soluble drug from the orifice[40].
- (3) use of various cyclodextrin derivatives to solubilize poorly water soluble drug [41-43].
- (4) use of alternative salt form that has optimum water solubility [44].
- (5) use of encapsulated excipients [45]
- (6) use of lyotropic crystals [46,47]
- (7) use of wicking agents.[48,49]

Delivery orifice

Majority of osmotic delivery systems contain at least one delivery orifice (preformed or formed in situ) in the membrane for drug release. Size of delivery orifice must be optimized to control the drug release from osmotic system. The size of the delivery orifice must be smaller than a maximum size S_{max} to minimize drug delivery by diffusion through the orifice. Furthermore, the area must be sufficiently large, above a minimum size S_{min} , to minimize hydrostatic pressure buildup in the system. Otherwise, the hydrostatic pressure can destroy the membrane and affect the zero-order delivery rate. Therefore, the cross-sectional area of the orifice should be maintained between the minimum and maximum values [50, 51]

Methods to create a delivery orifice in the osmotic tablet coating are:

(1) Laser drill

This technology is well established for producing sub-millimeter size hole in tablets. Normally, CO₂ laser beam (with output wavelength of 10.6 μ) is used for drilling purpose. It offers excellent reliability characteristics at low costs [52,53]

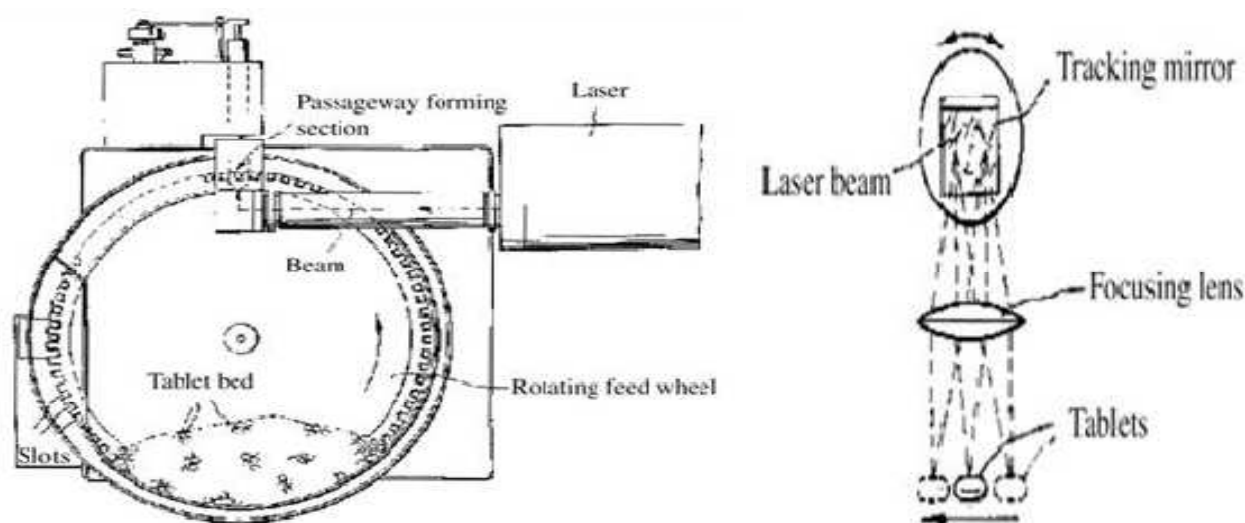

Fig. 1: Laser drilling process[52]

In simple words, the tablets in which holes are to be formed are charged in the hopper. The tablets drop by gravity into the slots of the rotating feed wheel and are carried at a predetermined velocity to the passageway forming station. At the passageway forming station, each tablet is tracked by an optical tracking system.

(2) Indentation that is not covered during the coating process [54]

Indentation is made in core tablets by using modified punches having needle on upper punch. This indentation is not covered during coating process which acts as a path for drug release in osmotic system.

(3) Use of leachable substances in the semipermeable coating

Incorporation of water-soluble additives in the membrane wall is the most widely reported method for the formation of pores in CPOP take place. These water-soluble additives dissolve on coming in contact with water, leaving behind pores in the membrane through which drug release takes place [55]

(4) Systems with passageway formed in situ:

The system consists of a tablet core of the drug along with water-swellaible polymer and osmotic agents, which is surrounded by a rate-controlling membrane. In contact with the aqueous environment, water is imbibed osmotically at a controlled rate and water swellaible polymer expands as the osmotic agents dissolves and increases the osmotic pressure

inside the tablet. This results in a rate-controlled slight expansion of the partially hydrated core. The expansion of core causes a small opening to form at the edge of the tablet (weakest point in the membrane) from where the formulation is released [56]

Osmotic pressure

The next release-controlling factor that must be optimized is the osmotic pressure gradient between inside the compartment and the external environment.

The release rate of a drug from an osmotic system is directly proportional to the osmotic pressure of the core proportional to the osmotic pressure of the core. The simplest and most predictable way to achieve a constant osmotic pressure is to maintain a saturated solution of osmotic agent in the compartment. If a saturated solution of the drug does not possess sufficient osmotic pressure, an additional osmotic agent must be added to the core formulation. The addition of carbonate or bicarbonate salt to the drug chamber offers an advantage since the effervescent action prevents the precipitated drug from blocking the delivery orifice in the tablet [57]. Polymeric osmagents are mainly used in the fabrication of PPOPs and other modified devices for controlled release of drugs with poor water solubility. These are swellaible, hydrophilic polymers that interact with the aqueous fluids and swell or expand to an equilibrium state.

Compound or Mixture	Osmotic Pressure (atm)
Lactose-Fructose	500
Dextrose-Fructose	450
Sucrose- Fructose	430
Mannitol- Fructose	415
Sodium Chloride	356
Fructose	335
Lactose-Sucrose	250
Potassium Chloride	245
Lactose-Dextrose	225

Mannitol-Dextrose	225
Dextrose-Sucrose	190
Mannitol-Sucrose	170
Sucrose	150
Mannitol-Lactose	130
Dextrose	82
Potassium Sulfate	39
Mannitol	38
Sodium Phosphate Tribasic.12H ₂ O	36
Sodium Phosphate Dibasic.7H ₂ O	31
Sodium Phosphate Dibasic.12H ₂ O	31
Sodium Phosphate Dibasic Anhydrous	29
Sodium Phosphate Monobasic.H ₂ O	28

Table 1: Osmotic pressure of saturated solution of commonly used osmogens

Semi permeable membrane [31,44]

Some of the membrane variables that are important in the design of oral osmotic system are:

Type and nature of polymer

Any polymer permeable to water but impermeable to solute can be selected. Some of the polymers that can be used for above purpose included in table 1.

Membrane thickness

Thickness of the membrane has a marked effect on the drug release from osmotic system, which is inversely proportional to each other.

Type and amount of plasticizer

In pharmaceutical coatings, plasticizers or low molecular weight diluents are added to modify the physical properties and improve film-forming characteristics of polymers. Plasticizers can change viscoelastic behavior of polymers significantly. In particular, plasticizers can turn a hard and brittle polymer into a softer, more pliable material, and

possibly make it more resistant to mechanical stress. These changes also affect the permeability of polymer films.

Types of osmotic pumps

Based on their design and the state of active ingredient, osmotic delivery systems can be classified as follows:

1. Osmotic delivery systems for solids

a. Type I: Single compartment.

In this design, the drug and the osmotic agent are located in the same compartment and are surrounded by the semipermeable membrane (SPM). Both the core components are dissolved by water, which enters the core via osmosis. A limitation is the dilution of drug solution with the osmotic solution, which affects the release rate of the drug from the system. Additionally, water-incompatible or water-insoluble drugs cannot be delivered effectively from a single compartment configuration.

b. Type II: Multiple compartments.

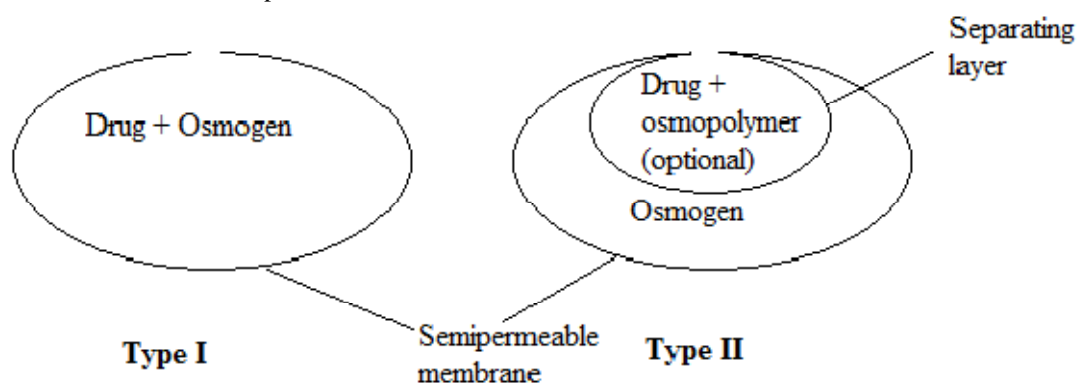

Figure 2. Classification of osmotic delivery systems: types I and II.

In this design, drug is separated from the osmotic compartment by an optional flexible film, which is displaced by the increased pressure in the surrounding osmotic

compartment, which, in turn, displaces the drug solution or suspension. The type II system inherently has greater utility than type I systems and can deliver drugs at a desired rate

independent of their solubilities in water. One main advantage of these systems is their ability to deliver drugs that are incompatible with commonly used electrolytes or osmotic agents.

2. Osmotic delivery systems for liquids

Active ingredients in liquid form are difficult to deliver from controlled release platforms because they tend to leak in their

native form. Therefore, liquid active agents typically are enclosed in a soft gelatin capsule, which is surrounded by an osmotic layer that, in turn, is coated with a semipermeable membrane. When the system takes up water from its surroundings, the osmotic layer squeezes the innermost drug reservoir. The increasing internal pressure displaces the liquid from the system via a rupturing soft gelatin capsule [58].

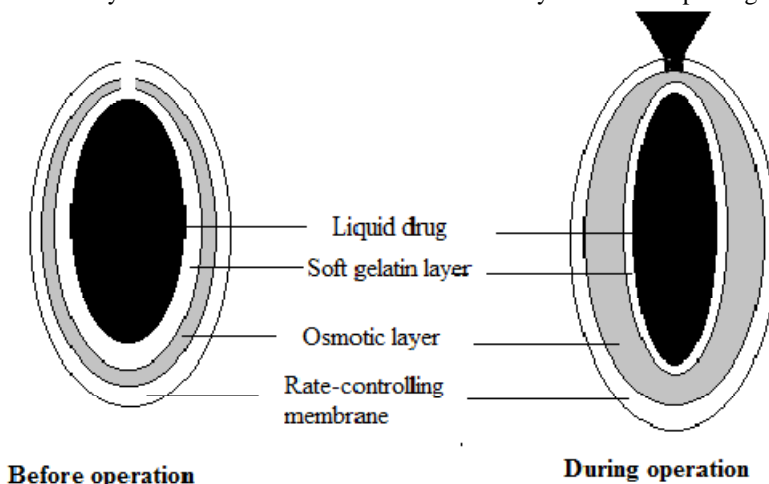

Figure 3: Osmotic delivery system for delivery of a liquid active agent.

Elementary osmotic pump (EOP)

The was introduced in 1970s to deliver drug at zero order rates for prolonged periods, and is minimally affected by environmental factors such as pH or motility. The tablet consists of an osmotic core containing the drug surrounded by a semipermeable membrane laser drilled with delivery orifice. Following ingestion, water in absorbed into system dissolving

the drug, and the resulting drug solution is delivered at the same rate as the water entering the tablet. The disadvantages of the elementary pump are that it is only suitable for the delivery of water soluble drugs [59,60].

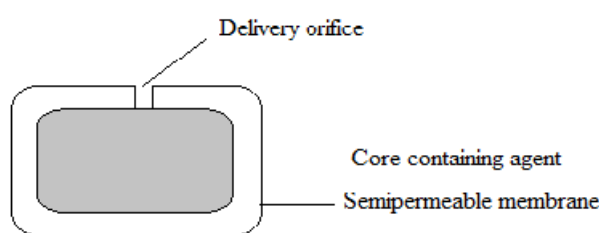

Figure 4: Elementary osmotic pump

Push-Pull Osmotic Pump (PPOP)

The two-layer push-pull osmotic tablet system appeared in 1980s. Push pull osmotic pump is a modified elementary osmotic pump through, which it is possible to deliver both poorly water-soluble and highly water soluble drugs at a constant rate. The push-pull osmotic tablet consists of two

layers, one containing the drug and the other an osmotic agent and expandable agent. A semipermeable membrane that regulates water influx into both layers surrounds the system. While the push-pull osmotic tablet operates successfully in delivering water-insoluble drugs, it has a disadvantage that the complicated laser drilling technology should be employed to drill the orifice next to the drug compartment [61].

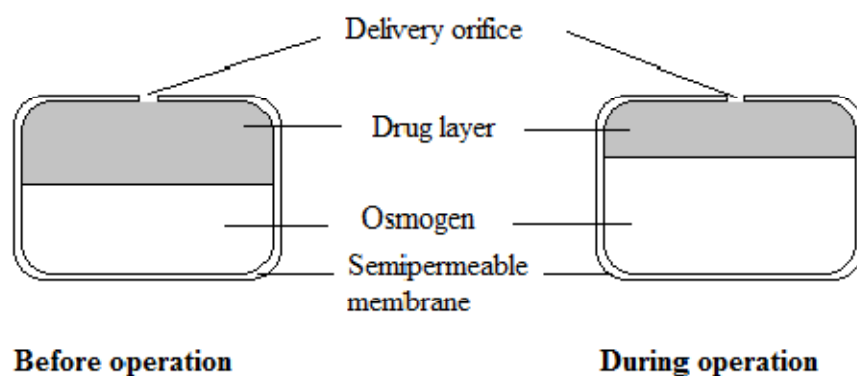

Figure 5: Push pull osmotic pump

Controlled Porosity Osmotic Pump

A controlled porosity osmotic pump-based drug delivery system Unlike the elementary osmotic pump (EOP) which consists of an osmotic core with the drug surrounded by a semipermeable membrane drilled with a delivery orifice, controlled porosity of the membrane is accomplished by the use of different channeling agents in the coating[62]. The CPOP contains water soluble additives in coating membrane, which after coming in contact with water; dissolve resulting in an in-situ formation of microporous membrane. Then the

resulting membrane is substantially permeable to both water and dissolved solutes and the mechanism of drug release from these system was found to be primarily osmotic, with simple diffusion playing a minor role [63,64]. Drug delivery from asymmetric membrane capsule is principally controlled by the osmotic pressure of the core formation. In-situ formed delivery orifice in the asymmetric membrane is mainly responsible for the solubilization in the core for a drug with poor water solubility [65].

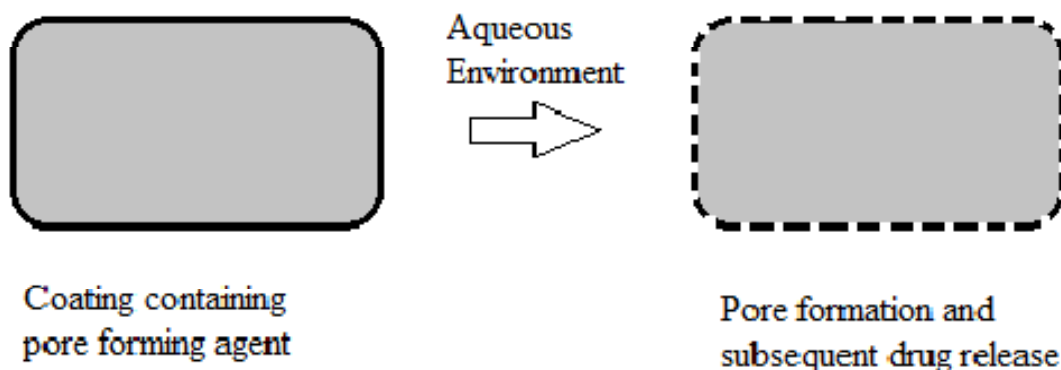

Figure 6: Controlled porosity osmotic pump

Osmotic bursting osmotic pump

This system is similar to an EOP expect delivery orifice is absent and size may be smaller. When it is placed in an aqueous environment, water is imbibed and hydraulic pressure is built up inside until the wall rupture and the content are released to the environment. Varying the thickness as well as the area the semipermeable membrane can control release of drug. This system is useful to provide pulsated release [66].

Telescopic capsule for delayed release

This device consists of two chambers, the first contains the drug and an exit port, and the second contains an osmotic engine. A layer of wax like material separates the two sections. To assemble the delivery device, the desired active agent is placed into one of the sections by manual or automated fill mechanism. The bilayer tablet with the osmotic engine is placed into a completed cap part of the capsule with the convex osmotic layer pointed in to the closed end of the cap and the barrier into the closed end of the cap and the

barrier layer exposed towards the cap opening. The open end of the filled vessel is fitted inside the open end of the cap, and the two pieces are compressed together until the cap, osmotic bilayer tablet and vessel fit together tightly. As fluid is imbibed the housing of the dispensing device, the osmotic engine expand and exerts pressure on the slidable connected first and second wall sections. During the delay period the volume of reservoir containing the active agent is kept constant, therefore a negligible pressure gradient exists between the environment of use and interior of the reservoir. As a result, the net flow of environmental fluid driven by the pressure enter the reservoir is minimal and consequently no agent is delivered for the period [67,68].

OROS-CT

OROS-CT (Alza corporation) is used as a once or twice a day formulation for targeted delivery of drugs to the colon. The OROS-CT can be a single osmotic agent or it can be comprised of as many as five to six push pull osmotic unit filled in a hard gelatin capsule. After coming in contact with the gastric fluids, gelatin capsule dissolved and the enteric coating prevents entry of fluids from stomach to the system as the system enters into the small intestine the enteric coating dissolves and water is imbibed into the core thereby causing the push compartment to swell. At the same time flowable gel is formed in the drug compartment, which is pushed out of the orifice at a rate, which is precisely controlled, by the rate of water transport across the semi permeable membrane. Incorporation of the cyclodextrin-drug complex has also been used as an approach for delivery of poorly water soluble drugs from the osmotic systems. Ex. Sulfobutylether-Bcyclodextrin sodium salt serves as a solubilizer and osmotic agent [69]

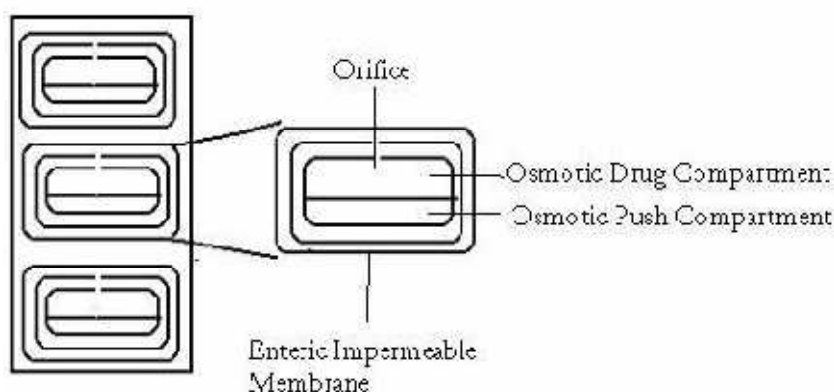

Figure 7: OROS-CT

Sandwiched Osmotic Tablets (SOTS)

In this a tablet core composed of polymeric push layer sandwiched between two drug layers with two delivery orifices. When placed in the aqueous environment the middle

push layer containing the swelling agent swells and the drug is released from the two orifices situated on opposite sides of the tablet and thus SOTS can be suitable for drugs prone to cause local irritation of the gastric mucosa [61].

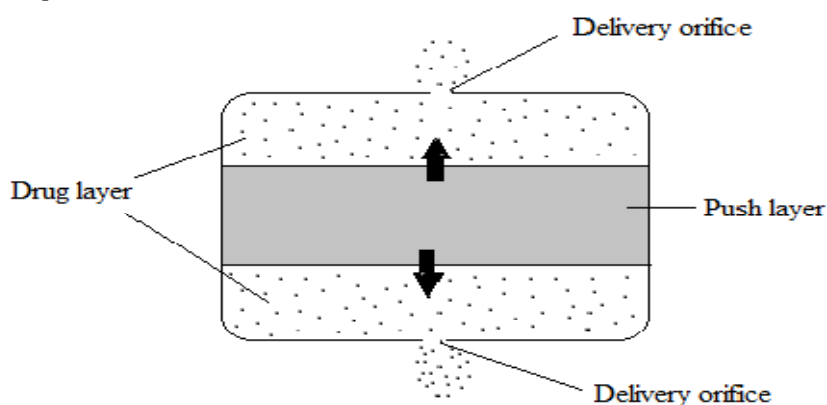

Figure 8: Sandwiched osmotic tablets

Longitudinally compressed tablet (LCT) multilayer formulation

The LCT multilayer formulation is the advanced design. As with the push-pull system it consists of an osmotic push layer and can be configured to contain several drug layers. The inclusion of multiple drug layers provides increased flexibility and control over the pattern of release of medication from the system, as opposed to the single layer used in the push-pull system, which can deliver a drug only in a zero order fashion. For example, two drug layers could be formulated with

different drug concentrations to provide modulation in the release rate profile. As with the push-pull formulation, water is absorbed through the exposed semipermeable tablet shell, expanding the push compartment and releasing the drug primarily through the first compartment through the laser drilled orifice at a predetermined controlled rate. After most of the drug release begins from the second compartment at a different rate. Varying the relative viscosity and hydrophilicity of the drug layer components can control the amount of mixing between the multiple drug layers. This allows even greater flexibility to achieve the target release profile.

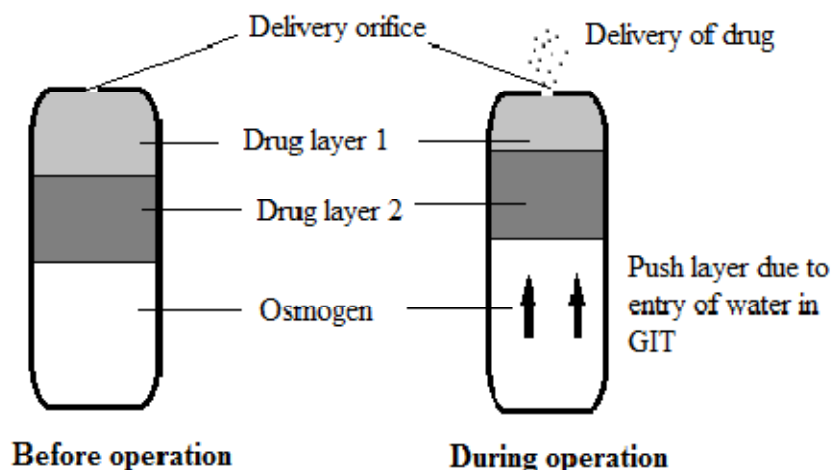

Figure 9: Multilayer osmotic pump

The LCT multilayer formulation can also be formulated with different drugs in different layers to provide combination therapy. Similar to the push-pull system, drug delivery by the LCT multilayer formulation can be unaffected by gastric pH, gut motility and the presence of food, depending on where in the GI tract the drug is released [70].

Pulsatile delivery system

Pulsatile systems are gaining a lot of interest as they deliver the drug at the right site of action at the right time and in the right amount, thus providing spatial and temporal delivery and increasing patient compliance. These systems are designed according to the circadian rhythm of the body. The principle rationale for the use of pulsatile release is for the drugs where a constant drug release, i.e., a zero order release is not desired.

The release of the drug as a pulse after a lag time has to be designed in such a way that a complete and rapid drug release follows the lag time. This type of tablet system consists of a core coated with two layers of swelling and rupturable coatings. Herein they used spray-dried lactose and microcrystalline cellulose in the drug core and then the core was coated with a swelling polymer cross-linked sodium and an outer rupturable layer of ethylcellulose. Pulsatile systems can be classified into single and multiple-unit systems. Single-unit systems are formulated either as capsule-based or osmosis-based systems. Single-unit systems are designed by coating the system either with eroding/soluble or rupturable coating. In multiple-unit systems, however, the pulsatile release is induced by changing membrane permeability or by coating with a rupturable membrane [71,72].

Marketed Product

Table 2: List of marketed product

Trade Name	Active ingredient	Design system
Alpress LP	Prazosin	Push -Pull
Acutrim	Phenylpropanolamine	Elementary pump
Cardura XL	Doxazosin	Push –Pull with time delay
Covera HS	Verapamil	Push -Pull
Ditropan XL	Oxybutinin chloride	Push -Pull
Dynacirc CR	Isradipine	Push -Pull
Invega	Paliperidone	Push -Pull
Efidac 24	Chlorpheniramine maleate	Elementary Pump
Glucotrol XL	Glipizide	Push -Pull
Minipress XL	Prazocine	Elementary Pump
Procardia XL	Nifedipine	Push -Pull
Sudafed 24	Pseudoephedrine	Elementary Pump

Conclusion

Osmotic pumps have come a long way in the field of drug delivery, starting from complex systems developed for research purposes to the osmotic pumps used for humans. In osmotic delivery systems, osmotic pressure provides the driving force for drug release. Increasing pressure inside the dosage form from water incursion causes the drug to release from the system. The major advantages include precise control of zero order or other patterned release over an extended time period—consistent release rates can be achieved irrespective of the environmental factors at the delivery site. Controlled delivery via osmotic systems also may reduce the side-effect profile by moderating the blood plasma peaks typical of conventional (e.g., instant release) dosage forms. Moreover, since efficacious plasma levels are maintained longer in osmotic systems. Further, with the discovery of newer and potent drugs by the biotechnology industry, the need to deliver such compounds at a precise rate certainly will pave the way for osmotic delivery systems to play an increasingly important role in drug delivery.

Conflict of interest statement

We declare that we have no conflict of interest.

References

1. Verma RK, Garg S. Current status of drug delivery technologies and future directions, *Pharm. Technol.-On Line* 2001; 25:1–14.
2. Prescott LF. The need for improved drug delivery in clinical practice. In: *Novel Drug Delivery and Its*

Therapeutic application, John Wiley and Sons, West Sussex, U.K., 1989. p. 1-11.

3. Verma RK, Mishra B, Garg S. Osmotically controlled oral drug delivery. *Drug Dev Ind Pharm* 2000; 26(7):695–708.
4. Baker R. Osmotic and mechanical devices. In: *Controlled Release of Biologically Active Agents*. New York: John Wiley, 1987.
5. Wright JC, Leonard ST, Stevenson CL, Beck JC, Chen G, et al. An in vivo/in vitro comparison with a leuprolide osmotic implant for the treatment of prostate cancer. *J Cont Rel* 2001; 75:1–10.
6. Verma RK, Krishna DM, Garg S. Formulation aspects in the development of osmotically controlled oral drug delivery systems. *J Cont Rel* 2002; 79:7-27.
7. <http://www.alza.com/alza/products>
8. <http://www.sccpc.com.cn/guanyuwomen/qikan/16/008.htm>.
9. Srikonda Sastry, Kotamraj Phanidhar and Barclay Brian: Osmotic controlled drug delivery system, in Li Xiaoling, Jasti Bhaskara R (eds), *Design of Controlled Release Drug Delivery Systems*, McGraw- Hill Companies, INC, New York 2006: 203-229.
10. McClelland GA, Sulton SC, Engle K and Zentner GM: The solubility–modulated osmotic pump: invitro / invivo release of diltiazem hydrochloride. *Pharma Res* 1991;8:88-92.
11. Li X, Jasti BR. Osmotic controlled drug delivery systems, In: *Design of controlled release of drug delivery systems*, McGraw Hill, 2006. p. 203-229.
12. Martin A. Solution of nonelectrolytes. In: *Physical Pharmacy*. 4th ed. New Delhi: B.I. Waverly, 1993.
13. Laxminarayanaiah N. *Transport Phenomena in Membranes*. New York: Academic Press, 1969, p. 247–248.
14. Theeuwes F, Swanson DR and Guittard G: Osmotic delivery systems for the betaadrenoceptor antagonists metoprolol and oxprenolol: Design and evaluation of systems for once-daily administration. *Br J Clin Pharmacol*, 1985; 19: 2:69S–76S.

15. Santus G and Baker RW: Osmotic drug delivery: A review of the patent literature. *J Control Release*, 1995; 35: 1:1–21.
16. Eckenhoff B, Theeuwes F and Urquhart J: Osmotically actuated dosage forms for rate-controlled drug delivery. *Pharm Technol* 1987; 11: 96–105.
17. Jensen JL, Appel LE, Clair JH and Zentner GM: Variables that affect the mechanism of drug release from osmotic pumps coated with acrylate/methacrylate copolymer latexes. *J Pharm Sci*, 1995; 84: 5:530-533.
18. Vyas, S.P and Khar, R.K: Controlled drug delivery: concept and advances. Vallabh prakashan, New Delhi, pp 477-501, 2001.
19. Suresh Vyas P, Prabakaran D, Paramjit Singh, Parijat Kanaujia, Jaganathan KS, Amith Rawat: Modified push-pull osmotic system for simultaneous delivery of Theophylline and Salbutamol: development and in vitro characterization. *Int. J. Pharm.* 2004; 284: 95-108.
20. Roger Rajewski A: Applicability of (SBE) 7m --CD in controlled-porosity osmotic pump tablets (OPTs). *Int. J. Pharm.* 2004; 286: 81-88.
21. Roger Rajewski A: Factors affecting membrane controlled drug release for an osmotic pump tablet utilizing (SBE)7m - CD as both a solubilizer and osmotic agent. *J. Control. Rel.* 1999; 60: 311-319.
22. Giancarlo Santus, and Richard Baker W: Osmotic drug Delivery: a review of the patent literature. *J Control. Rel.* 1995; 35: 1- 21.
23. Kazuto Okimoto, Roger A. Rajewski, and Valentino J. Stella: Release of testosterone from an osmotic pump tablet utilizing (SBE)7m- β -cyclodextrin as both a solubilizing and an osmotic pump agent *J. Control. Rel.* 1999; 58: 29-38.
24. Hai Bang Lee, Longxiao Liu, Jeong Ku, Gilson Khang, Bong Lee, John M. Rhee: Nifedipine controlled delivery sandwiched osmotic tablet system. *J. Control. Rel.* 2000; 68: 145-156.
25. Toshiaki Nagakura, Ken Ishihara, Toshiyuki Furukawa, Kohji Masuda, Takao Tsuda: Auto-regulated Osmotic pump for insulin therapy by sensing glucose concentration without energy supply. *Sensors and Actuators B.* 1996; 34: 229-233.
26. Herbig SM., Cardinal J.R. and Korsmeyer K.L., Smith KL: Asymmetric membrane tablet coatings for osmotic drug delivery. *J. Control. Rel.* 1995; 35: 127-136.
27. Mahalaxmi R, Phanidhar Sastri, Ravikumar, Atin Kalra, Pritam Kanagale and Narkhede. Enhancement of Dissolution of Glipizide from Controlled Porosity Osmotic Pump Using a Wicking Agent and a Solubilizing Agent. *Int. J. Pharm Tech Res.* 2009; 1, (3): 705-711.
28. Pradeep Vavia R and Sapna Makhija N: Controlled porosity osmotic pump-based controlled release systems of pseudoephedrine 1. Cellulose acetate as semipermeable membrane. *J. Control. Rel.* 2003; 89; 5-18.
29. Ji-Eon Kim, Seung-Ryul Kim, Sun-Hee Lee, Chi-Ho Lee and Dae-Duk Kim: The effect of pore formers on the controlled release of cefadroxil from a polyurethane matrix. *Int. J. Pharm.* 2000; 201: 29-36.
30. Srikonda Sastry, Kotamraj Phanidhar and Barclay Brian: Osmotic controlled drug delivery system, in Li Xiaoling, Jasti Bhaskara R (eds), Design of Controlled Release Drug Delivery Systems, McGraw- Hill Companies, INC, New York 2006: 203-229.
31. Theeuwes F. Elementary osmotic pump. *J Pharm Sci* 1975; 64(12):1987–1991.
32. Verma RK, Krishna DM, Garg S. Formulation aspects in the development of osmotically controlled oral drug delivery systems. *J Cont Rel* 2002; 79:7–27.
33. McClelland GA, Sutton SC, Engle K, Zentner GM. The solubility-modulated osmotic pump: in vitro/in vivo release of diltiazem hydrochloride. *Pharm Res* 1991; 8(1):88–92.
34. Zentner GM, McClelland GA, Sutton SC. Co006Etrolled porosity solubility- and resinmodulated osmotic drug delivery systems for release of diltiazem hydrochloride. *J Cont Rel* 1991; 16:237–244.
35. Zentner GM, McClelland GA; Merck & Co., assignee. Solubility modulated drug delivery device. US Patent 4,994,273. Feb. 19, 1991.
36. McClelland GA, Zentner GM; Merck & Co., assignee. Solubility modulated drug delivery system. US Patent 4,946,686. Aug. 7, 1990.
37. Herbig SM, Cardinal JR, Korsmeyer RW, Smith KL. Asymmetric-membrane tablet coatings for osmotic drug delivery. *J Cont Rel* 1995; 35:127–136.
38. Verma RK, Mishra B. Studies on formulation and evaluation of oral osmotic pumps of nimesulide. *Pharmazie* 1999; 54:74–75.
39. Verma RK, Garg S. Development and evaluation of osmotically controlled oral drug delivery system of glipizide. *Eur J Pharm Biopharm* 2004; 75(3):513–525.
40. Theeuwes F; ALZA Corp., assignee. Osmotic dispenser with gas generating means. US Patent 4,036,228. July 19, 1977.
41. Okimoto K, Miyake M, Ohnishi N, Rajewski RA, Stella VJ, Irie T, et al. Design and evaluation of an osmotic pump tablet (OPT) for prednisolone, a poorly water soluble drug, using (SBE) m-beta-CD. *Pharm Res* 1998; 15:1562–1568.
42. Okimoto K, Ohike A, Ibuki R, Aoki O, Ohnishi N, Irie T, et al. Design and evaluation of an osmotic pump tablet (OPT) for chlorpromazine using (SBE)m-B-CD. *Pharm Res* 1999; 16:549–554.
43. Okimoto K, Rajewski RA, Stella VJ. Release of testosterone from an osmotic pump tablet utilizing (SBE) m-beta-CD as both a solubilizing and an osmotic pump agent. *J Cont Rel* 1999; 58:29–38.
44. Theeuwes F, Swanson DR, Guittard G, Ayer A, Khanna S. Osmotic delivery systems for the β -adrenoceptor antagonists metoprolol and oxprenolol: design and evaluation of systems for once-daily administration. *Br J Clin Pharmacol* 1985; 19:69S-76S.
45. Thombre AG, DeNoto AR, Gibbes DC. Delivery of glipizide from asymmetric membrane capsules using encapsulated excipients. *J Cont Rel* 1999; 60:333–341.
46. Curatolo WJ; Pfizer Inc., assignee. Dispensing devices powered by lyotropic liquid crystals. US Patent 5,030,452. Jul. 9, 1991.
47. Curatolo WJ; Pfizer Inc., assignee. Dispensing devices powered by lyotropic liquid crystals. US Patent 5,108,756. Apr. 28, 1992.
48. Rudnic EM, Burnside BA, Flanner HH, Wassink SE, Couch RA, Pinkett JE; Shire labs, assignee. Osmotic dose delivery system. US Patent 6,110,498. August 29, 2000.
49. Rudnic EM, Burnside BA, Flanner HH, Wassink SE, Couch RA, Pinkett JE; Shire labs, assignee. Soluble form osmotic

- dose delivery system. US Patent 6,361,796. March 26, 2002.
50. Good WR, Lee PI. Membrane-controlled reservoir drug delivery systems. In Langer RS, Wise DL, editors. *Medical Applications of Controlled Release*. Vol. I. Boca Raton, CRC Press, 1984. p. 1–39.
 51. Theeuwes F, Higuchi T. Osmotic dispensing device with maximum and minimum sizes for the passageway, U.S. Patent 3,916,899, 1975.
 52. Gaebler F. Laser drilling enables advanced drug delivery systems. Coherent article for *Pharmaceutical Manufacturing* 2007:1-7.
 53. Theeuwes F, Saunders RJ, Mefford WS. Process for forming outlet passageways in pills using a laser. US Patent 4088864; 1978.
 54. Liu L, Wang X. Solubility modulated monolithic osmotic pump tablet for atenolol delivery. *Eur. J. Pharm Biopharm.* 2008; 68(2):298-302.
 55. Zentner GM, Rork GS, Himmelstein KJ. Osmotic flow through controlled porosity films: An approach to delivery of water soluble compounds. *J. Cont Rel* 1985; 2:217–229.
 56. Chen C, Lee D, Xie J. Controlled release formulation for water insoluble drugs in which a passageway is formed insitu. US patent 5,736,159, April 7, 1998.
 57. Jerzewski RL, Chien YW. Osmotic drug delivery. In: Kydonieus A, editors. *Treatise on Controlled Drug Delivery: Fundamentals, Optimization, Application*, Marcel Dekker, New York, 1992. p. 225–253.
 58. Srikonda Sastry, Kotamraj Phanidhar, Barclay Brian, Osmotic controlled drug delivery system, in Li Xiaoling, Jasti Bhaskara R (eds), *Design of Controlled Release Drug Delivery Systems*, McGraw-Hill Companies, INC, New York, pp 203- 229,2006
 59. Theeuwes, F. Elementary Osmotic Pump. *J Pharm Sci*, 1975; 64:1987-1991.
 60. Theeuwes F, Swanson D, Wong P, Bosen P, Place V, Heimlich K, Kwan KC. elementary osmotic pump for indometacin. *J pharm Sci* 1983; 72:253- 258.
 61. Liu L, Ku J, Khang G, Lee B, Rhee JM, Lee HB. Nifedipine controlled delivery by sandwiched osmotic tablet system. *J Control Release*, 2000; 68:145–156.
 62. Makhija Sapna N, Vavia Pradeep R. Controlled porosity osmotic pump-based controlled release systems of pseudoephedrine I: Cellulose acetate as a semipermeable membrane. *J Control Release*, 2003;89:5–18
 63. Haslem J, Rork GS. Controlled porosity osmotic pump. US Patent 488063, 1989.
 64. Thombrea AG, Cardinall JR, DeNoto AR, Herbig SM, Smith KL. Asymmetric membrane capsules for osmotic drug delivery: Development of a manufacturing process. *J Control Release*, 1999; 57:55-64.
 65. Zentner GM, Rork GS, Himmelsteine KJ. Osmotic flow through controlled porosity films: an approach to deliver water soluble compounds. *J Control Release*, 1985; 2:217-229.
 66. Parmar NS, Vyas SK, jain NK. *Advances in controlled and novel drug delivery*. CBS publisher & distributors, New Delhi, pp 18-39, 2001.
 67. Kaushal AM, Garg S. An update on osmotic drug delivery patents. *Pharm Tech*, Aug 2003; 27:38-44.
 68. Theuwes, F.; Wong, P.S.L.; Burkoth, T.L.; Fox, D.A.; Bicek, P.R., *Colonic drug absorption and metabolism*. Marcel Decker, New York, pp 137-158, 1993.
 69. Madhavi BB, Nath AR, Banji D, Ramalingam R, Madhu MN, Kumar DS. Osmotic drug delivery system: a review. *Pharmakine*, 2009;2:5-14.
 70. Conley R, Gupta SK, Satyan G. Clinical spectrum of the osmotic controlled release oral delivery system (OROS): an advanced oral delivery form. *Current medical research and opinion*, 2006; 22:1879-1892.
 71. Arora S, Ali J, Ahuja A, Baboota S, Qureshi J. Pulsatile drug delivery systems: An approach for controlled drug delivery. *Ind J Pharm Sci*, 2006; 68: 3:295-300.
 72. Kakar Satinder, Singh Ramandeep, Batra Deepa, Nautiyal Ujjwal. Review on recent trends in pulsatile drug delivery systems. *Universal journal of pharmacy*, 2013;2(1):21-41.

Cite this article as: Neetu R.Gupta, Asish Dev, Aditee Mishal, Supriya Shetty. A Review on Recent Innovation in osmotically controlled drug delivery system. **Indian J. Pharm. Biol. Res.**2014; 2(2):117-129.

All © 2014 are reserved by Indian Journal of Pharmaceutical and Biological Research

This Journal is licensed under a **Creative Commons Attribution-Non Commercial -Share Alike 3.0 Unported License**. This article can be downloaded to **ANDROID OS** based mobile.