

# Cryogenic measurement of the optical absorption coefficient in sapphire crystals at $1.064 \mu\text{m}$ for the Large-scale Cryogenic Gravitational wave Telescope

Takayuki Tomaru<sup>1</sup>, Takashi Uchiyama<sup>2</sup>, Daisuke Tatsumi<sup>3</sup>,  
Shinji Miyoki, Masatake Ohashi, Kazuaki Kuroda

*Institute for Cosmic Ray Research (ICRR), The University of Tokyo, 5-1-5,  
Kashiwanoha, Kashiwa, Chiba, 277-8582, Japan*

Toshikazu Suzuki, Akira Yamamoto, Takakazu Shintomi

*High Energy Accelerator Research Organization (KEK), 1-1 Oho, Tsukuba,  
Ibaraki, 305-0801, Japan*

---

## Abstract

We have applied laser calorimetry to the measurement of optical absorption in monocrystalline sapphire at cryogenic temperatures. Sapphire is a promising candidate for the mirror substrates of the Large-scale Cryogenic Gravitational wave Telescope. The optical absorption coefficients of different sapphire samples at a wavelength of  $1.064 \mu\text{m}$  at 5 K were found to average 90 ppm/cm.

*Key words:* Optical absorption; Sapphire; Cryogenics; Laser calorimetry; Gravitational wave detector; Laser interferometer; LCGT

---

## 1 Introduction

Large scale laser interferometers such as TAMA[1], LIGO[2], VIRGO[3] and GEO[4], are being developed for the direct detection of gravitational waves

<sup>1</sup> Corresponding author. E-mail address: tomaru@icrr.u-tokyo.ac.jp

<sup>2</sup> Present address: High Energy Accelerator Research Organization (KEK), 1-1 Oho, Tsukuba, Ibaraki, 305-0801, Japan

<sup>3</sup> Present address: National Astronomical Observatory (NAO), Mitaka, Tokyo, 181-8588, Japan

(GW). TAMA has already reached a stage where high quality data can be taken for several hours at a time[5]. However, much more sensitive detectors are planned because the estimated GW event rate for coalescing neutron star binaries is extremely low even within the Virgo cluster (at a radius of 20 Mpc, and the main target of LIGO and VIRGO). The important limitations to the sensitivity of these interferometers are seismic vibration, thermal Brownian noise of mirrors and their suspensions[6], and photon shot noise. Although fused silica is used in present interferometers as the main mirror substrate, it is not the best material for advanced GW interferometers, due to concerns about thermal Brownian noise and thermal lensing[7,8] at very high optical power. Another promising candidate material is mono-crystalline sapphire, but concerns about thermo-elastic noise[9,10] render sapphire unsuitable if used at room temperature.

We have been developing a cryogenic mirror technique to be used in the Large-scale Cryogenic Gravitational wave Telescope (LCGT)[11]. Sapphire will be used due to its extremely high Q[12], large thermal conductivity and small thermal expansion coefficient at cryogenic temperature. These characteristics drastically reduce the effects of thermal Brownian noise, thermal lensing and thermo-elastic noise[13]. However, concerns have been raised about possible large optical absorption in sapphire, which would lead to increased thermal lensing. Room temperature measurements of optical absorption in sapphire reported by several groups exhibit a wide spread of values from 3 ppm/cm to 140 ppm/cm, even where measurements were made on the same sample[14,15]. In these measurements, the photothermal technique[16,17] was used, which is an indirect method.

As a fundamental study towards the development of LCGT, we measured the optical absorption coefficient in sapphire at cryogenic temperature using laser calorimetry[16,18]. Laser calorimetry at cryogenic temperatures has merit as a measurement method;

- (1) Since it is a direct measurement, it doesn't rely on detailed knowledge of other material parameters such as specific heat, thermal conductivity and temperature coefficient of refractive index.
- (2) Since the thermal radiation from samples is very small at cryogenic temperature, small absorbed laser power makes a relatively large temperature increase, easily measured to high precision.
- (3) Since the temperature in the cryostat is very stable, this measurement technique is very insensitive to changes in the surroundings.
- (4) Highly sensitive thermometers are available for the measurement of cryogenic temperatures. Carbon-Glass Resistance (CGR) thermometers were used in this measurement, which have an accuracy of better than 1 mK near liquid helium temperatures.

## 2 The principle of measurement

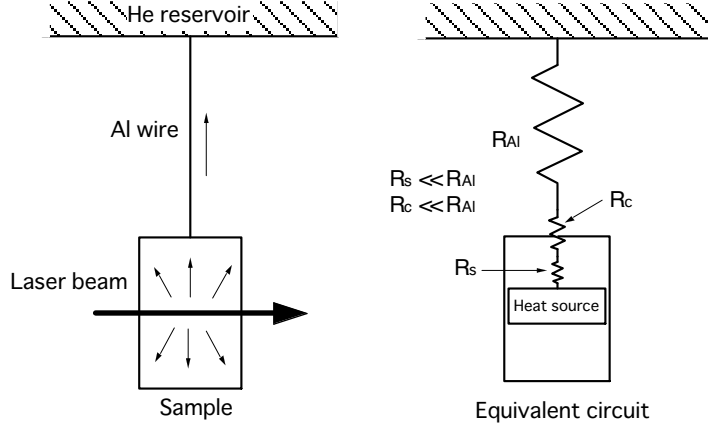

Fig. 1. Equivalent circuit of this measurement.  $R_s$ : Thermal resistance of the sample,  $R_c$ : Contact resistance between the sample and the aluminum wire,  $R_{AI}$ : Thermal resistance of the aluminum wire.  $R_{AI}$  was chosen to be much larger than  $R_s$  and  $R_c$ .

Changes are measured in the steady state temperature of the sample for varying incident laser powers, after cooling the sapphire sample to liquid helium temperature using thermal conduction through an aluminum wire. In short, this measurement is equivalent to measuring the thermal resistance of the aluminum wire. Figure 1 shows the equivalent circuit of this measurement. Since the thermal resistance in the sapphire sample is much smaller than one of the aluminum wire, we can ignore the distribution of temperature within the sample. We can formulate a thermal equation for the steady state temperature  $T(x)$  in the aluminum wire and the two corresponding boundary conditions as follows:

$$-\kappa \frac{d^2 T(x)}{dx^2} = 0, \quad (1)$$

$$T(0) = T_0, \quad (2)$$

$$\kappa \frac{dT(L)}{dx} S = P, \quad (3)$$

where  $\kappa$  is the thermal conductivity of the aluminum wire,  $T_0$  is the temperature of the end of the aluminum wire connected to the helium reservoir (equivalent to the initial temperature of the sample),  $L$  is the length of the aluminum wire,  $S$  is the cross sectional area of the aluminum wire, and  $P$

is the input heat power into the sample, which is equivalent to the absorbed laser power. The origin of the x-axis was chosen at the end of the aluminum wire. Generally, thermal conductivity  $\kappa$  depends on temperature, however we can assume it to be constant because the change of the sample temperature is at largest 100 mK. The error caused by this assumption is at most a few percent. Integrating the above equations, the steady state temperature at the sample  $T(L)$  can be written as,

$$T(L) = R_{Al} \cdot P + T_0, \quad (4)$$

$$R_{Al} \equiv \frac{L}{\kappa S}. \quad (5)$$

The steady state temperature at the sample is proportional to the input power. The thermal resistance  $R_{Al}$  was determined using a heater that produces known heat power. Other errors concerning heat flux are also canceled by calibrating in this way. After calibration, we can obtain the optical absorption coefficient  $\alpha$ ,

$$\alpha = \frac{1}{l} \frac{P_{abs}}{P_{las}} = \frac{1}{l P_{las}} \frac{T(L) - T_0}{R_{Al}}, \quad (6)$$

where  $P_{abs}$  is the laser power absorbed in the sample,  $P_{las}$  is the laser power injected into the sample and  $l$  is the length of the sample.

Figure 2 shows the experimental setup. A 1.064  $\mu\text{m}$  Nd:YAG laser was used in this measurement. This laser has 700 mW output power with a power stability of 0.1 %. Injected laser power was measured by a power meter with an accuracy of 3 % and net laser power in the sample was calculated considering multi-reflection within the sample[19]. The sapphire sample was held in a pure aluminum mounting, itself mounted on Teflon rods. An aluminum wire was tightened between the holder and the sample in a crush joint, and thermally connected to the helium reservoir. A CGR thermometer and a manganin heater were mounted in the holder. The thermometer and heater wires were both manganin and superconducting. The diameter and length were optimized to be able to ignore both the production and the conduction of heat. We could measure a small thermal contact resistance between the sample and the aluminum holder, and we corrected for this after post-experiment measurement of the crushed area of the aluminum wire. Since some reports mention that the sensitivity of laser calorimetry is limited by the heat produced by light scattered from the sample to the thermometer[16], we suspended another CGR thermometer as a scattering monitor near the sample to further investigate.

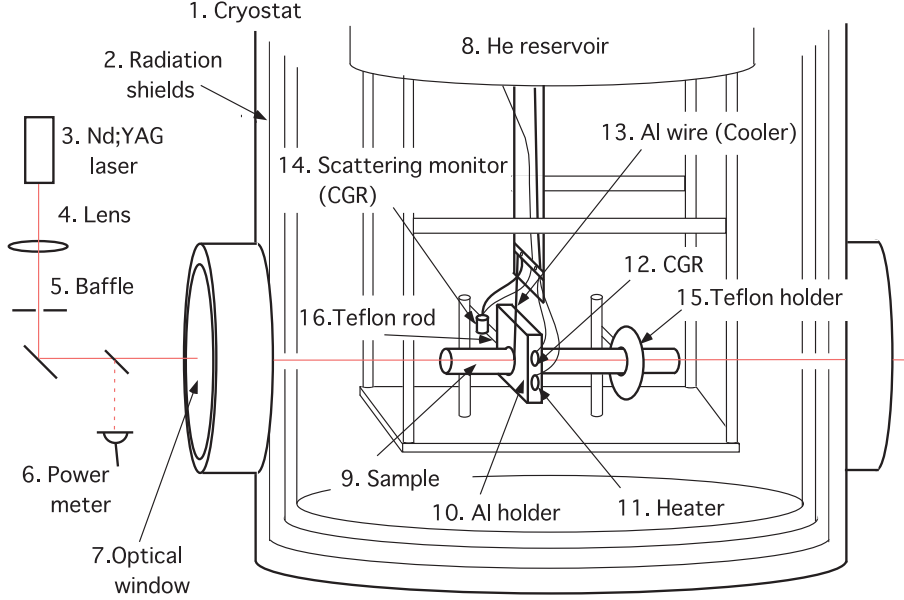

Fig. 2. The setup for the optical absorption measurement in the sapphire crystals at cryogenic temperature. 1; Cryostat, 2; Radiation shields, 3; Nd:YAG laser, 4; Lens, 5; Baffle, 6; Power meter, 7; Optical window, 8; Helium reservoir, 9; Sample, 10; Aluminum holder, 11; Manganin heater, 12; CGR thermometer, 13; Aluminum wire (Cooler), 14; Scattering monitor (CGR thermometer), 15; Teflon holder, 16; Teflon rod.

### 3 Result

We measured two mono-crystalline sapphire samples, both manufactured by Crystal Systems Inc. using the Heat Exchange Method[20]. The grades of these samples were specified as "CSI white high purity" and "Hemlite", respectively. These sapphire grades are characterized by the homogeneity of refractive index. Typical homogeneity of the refractive index for CSI white is  $1 \times 10^{-6}$  and that for Hemlite is  $3 \times 10^{-6}$ [20]. The CSI white sample was 10 mm in diameter and 150 mm in length (cylinder axis was parallel to the  $c$ -axis). The Hemlite sample was 100 mm in diameter and 60 mm in thickness (again parallel to the  $c$ -axis). All surfaces of the samples were optically polished. Though these samples had been annealed during the process of crystal growth, they were not re-annealed after polishing. We measured at three spatially different points on each sample to confirm that our measurement was not affected by the heat produced by surface dust or defects, and to examine whether there was any inhomogeneity of absorption. Measurements were repeated more at least twice at each point. The samples were cooled to 5 K and the temperature rise due to absorption of laser power was at most 100 mK. Figure 3 shows the steady state temperature at the first measurement point in the CSI white sample. Measurements were done twice at this point. The error bars were derived from the maximum fluctuation of electrical output from the thermometer, which was  $\pm$

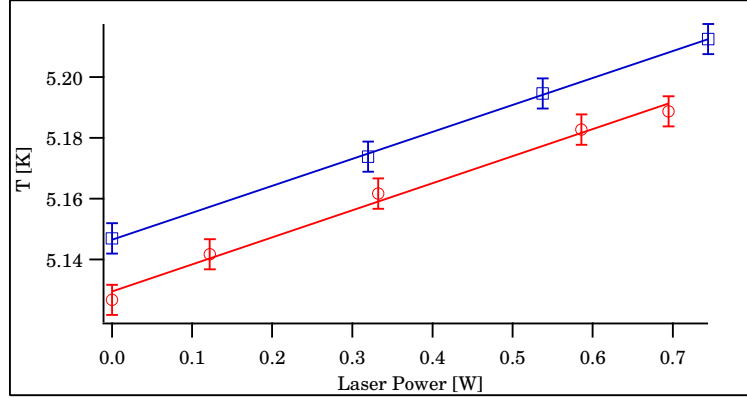

Fig. 3. The steady state temperatures at point 1 in the CSI white sample risen by some injecting laser powers. Measurements were done twice in this point. The open circles show the first measurement and open squares show the next measurement.

0.3%, corresponding to  $\pm 5$  mK temperature error. A small drift of the initial temperature of these two measurements was caused by a change of a depth of liquid helium in the reservoir, however this drift is much slower than the measurement time of absorption. We are only interested in the derivatives, which are then compared to the calibration made using the heater.

Table 1

The results of the optical absorption coefficients in sapphire samples at  $1.064 \mu\text{m}$  at 5 K.

Point	CSI white high purity [ ppm/cm ]	Hemlite [ ppm/cm ]
1	$93 \pm 9$	$99 \pm 13$
2	$88 \pm 12$	$90 \pm 10$
3	$93 \pm 10$	$90 \pm 10$

Table 1 shows the measured optical absorption coefficient at each point. The optical absorption coefficients in the CSI white sample ranged from 88 ppm/cm to 93 ppm/cm. The optical absorption coefficients in the Hemlite sample ranged from 90 ppm/cm to 99 ppm/cm. The errors were about  $\pm 10$  ppm/cm for all measurements. No heat production by light scattering from the sample was observed at the scattering monitor (CGR). We did not find a large difference in the optical absorption between our cryogenic result and a previous report at room temperature[15].

## 4 Conclusion

We measured optical absorption in two sapphire samples, which were manufactured by Crystal Systems Inc., at  $1.064 \mu\text{m}$  wavelength at 5 K, using a

700 mW laser. The optical absorption coefficients for the CSI white sample ranged from 88 ppm/cm to 93 ppm/cm. The optical absorption coefficients for the Hemlite sample ranged from 90 ppm/cm to 99 ppm/cm. In both samples, the measurement errors were about  $\pm 10$  ppm/cm.

Our studies of thermal lensing have already confirmed that thermal lensing will be negligible in interferometric GW detectors which use cryogenic sapphire mirrors. This research will be fully reported in an upcoming paper. The only remaining problem caused by sapphire's large optical absorption is mirror cooling. In the case of LCGT, which proposes a 10 cm mirror length and 2.5 kW of laser power passing through each of the near mirrors, a heat power of 2 W is deposited by direct optical absorption (assuming 90 ppm/cm). From previous studies of cryogenic sapphire mirrors[21,22], the optical absorption must be reduced by one order of magnitude to allow LCGT's sapphire mirrors to operate at a temperature to 30 K. This calculation assumes a 1 mm diameter and 250 mm length for each of the the four sapphire fibers used as heat conductors. The integrated thermal conductivity of the sapphire fibers between 4.2 K and 30 K was taken to be  $3 \times 10^4$  W/m[22].

The sources of the optical absorption are suspected to be impurities or lattice defects. We have confirmed the presence of  $\text{Ti}^{3+}$ ,  $\text{Cr}^{3+}$  and other unidentified impurities in these samples. However, we have not yet identified the true sources of optical absorption at  $1.064 \mu\text{m}$ . This problem will be addressed in a future study.

The cryogenic measurement of optical absorption established in this study can be used in the development of optical components for the advanced interferometric gravitational wave detectors.

## Acknowledgements

This study was supported by the Joint Research and Development Program of KEK and by a grant-in-aid from the Japanese Ministry of Education, Science, Sports and Culture. We thank Dr. C. T. Taylor for useful advice in the preparation of this manuscript.

## References

- [1] K. Kuroda et al., Proceedings of the international conference on gravitational waves: source and detectors, I. Ciufolini, F. Fidecaro, ed., World Scientific, Singapore, (1997) 100 .

- [2] A. Abramovici et al., *Science* **256** (1992) 325.
- [3] C. Bradaschina et al., *Nucl. Instrum. Methods Phys. Res. A* **256** (1990) 518.
- [4] K. Danzmann et al., *Proceedings of the first E. Amaldi Conference on Gravitational Wave Experiments*, E. Coccia, G. Pizzella, F. Ranga, ed., World Scientific, Singapore, (1995) 100.
- [5] H. Tagoshi et al., accepted to *Phys. Rev. D*, gr-qc/0012010.
- [6] P. R. Saulson, *Phys. Rev. D* **42** (1990) 2437.
- [7] P. Hello and J. Y. Vinet, *J. Phys. France* **51** (1990) 1267.
- [8] W. Winkler et al., *Phys. Rev. A* **44** (1991) 7022.
- [9] V. B. Braginski et al., *Phys. Lett. A* **264** (1999) 1.
- [10] Y. T. Liu and K. S. Thorne, *Phys. Rev. D* **62** (2000) 122002.
- [11] K. Kuroda et al., *Int. J. Mod. Phys. D* **8** (1999) 557.
- [12] T. Uchiyama et al., *Phys. Lett. A* **261** (1999) 5.
- [13] M. Cerdonio et al., gr-qc/0009104.
- [14] D. G. Blair et al., *Opt. Mater.* **8** (1997) 233.
- [15] Route et al., <http://www.ligo.caltech.edu/docs/G/G000072-00.pdf>.
- [16] A. Hordvik, *Appl. Opt.* **16** (1977) 2827.
- [17] P. Y. Baurès and C. N. Man, *Opt. Mater.* **2** (1993) 241.
- [18] M. Hass et al., *Appl. Opt.* **14** (1975) 1128.
- [19] E. R. Pike et al., *J. Chem. Phys.* **62** (1975) 3188.
- [20] C. P. Khattak et al., *Window and Dome Technologies and Materials 5*, R. W. Tustison, ed., *Proc. SPIE*, Vol. 3060, (1997) 250.
- [21] T. Uchiyama et al., *Phys. Lett. A* **242** (1998) 211.
- [22] T. Uchiyama, Ph. D. thesis, Tokyo University (1999)