



ELSEVIER

J. Non-Newtonian Fluid Mech., 81 (1999) 133–178

**Journal of
Non-Newtonian
Fluid
Mechanics**

The yield stress—a review or ‘ $\pi\alpha\nu\tau\alpha$ ρει’—everything flows?

Howard A. Barnes

Unilever Research Port Sunlight, Bebington, Wirral, L63 3JW Merseyside, UK

Received 30 March 1998; received in revised form 4 May 1998

Abstract

An account is given of the development of the idea of a yield stress for solids, soft solids and structured liquids from the beginning of this century to the present time. Originally, it was accepted that the yield stress of a solid was essentially the point at which, when the applied stress was *increased*, the deforming solid first began to show *liquid*-like behaviour, i.e. continual deformation. In the same way, the yield stress of a structured liquid was originally seen as the point at which, when *decreasing* the applied stress, *solid*-like behaviour was first noticed, i.e. no continual deformation. However as time went on, and experimental capabilities increased, it became clear, first for solids and lately for soft solids and structured liquids, that although there is usually a small range of stress over which the mechanical properties change dramatically (an apparent yield stress), these materials nevertheless show slow but continual steady deformation when stressed for a long time *below* this level, having shown an *initial* linear elastic response to the applied stress. At the lowest stresses, this creep behaviour for solids, soft solids and structured liquids can be described by a Newtonian-plateau viscosity. As the stress is increased the flow behaviour usually changes into a power-law dependence of steady-state shear rate on shear stress. For structured liquids and soft solids, this behaviour generally gives way to Newtonian behaviour at the highest stresses. For structured liquids this transition from very high (creep) viscosity ($> 10^6$ Pa.s) to mobile liquid (< 0.1 Pa.s) can often take place over a single order of magnitude of stress. This extreme behaviour, when viewed on a linear basis, gave every reason for believing that the material had a yield stress, and in many cases the flow curve seemed to be adequately described by Bingham's simple straight-line-with-intercept equation. However, if viewed on a logarithmic basis, the equally simple Newtonian/power-law/Newtonian description is clearly seen. (One evident implication of these statements is that $\pi\alpha\nu\tau\alpha$ ρει—everything flows!) Although we have shown that, as a physical property describing a critical stress below which no flow takes place, yield stresses do not exist, we can, without any hesitation, say that the *concept* of a yield stress has proved—and, used correctly, is still proving—very useful in a whole range of applications, once the yield stress has been properly defined. This proper definition is as a mathematical curve-fitting constant, used along with other parameters to produce an equation to describe the flow curve of a material over a *limited* range of shear rates. This equation can then be used to predict the behaviour of that material in different geometries. However,

it should only be used over the same range of shear rates that the original characterisation and curve fitting were undertaken. Here we show how best to deal with such situations, and we emphasise that the simplest-possible adequate ‘yield-stress’ equation should be used. © 1999 Elsevier Science B.V. All rights reserved.

Keywords: Yield stress; Shear rate; Yield point

1. Introduction

1.1. General

The subject of yield stresses has, in the last decade or so, generated a fair amount of debate in the rheological literature (see below for details). Following a previous paper by this author in 1985 [1], some writers using the expression tried to clarify what they meant by yield stress, rather than simply introducing it without cautious definition. However, there is still enough unenlightened and uncritical use of the expression by some authors—who seem unaware of the controversy that has gone on—to justify a review of the subject, and possibly to round off discussion in the area.

As an example of the continued importance of yield stresses and allied ideas, we note that in the last dozen years or so the phrases *yield stress* or *yield point* have been cited nearly 2500 times in the general scientific and engineering literature (All citation statistics quoted here are derived from the Institute for Scientific Information Citation Databases, 1985 to date). As to the particular continued use of the concept in Rheology, we note that in a recent, extra-large volume of Rheology Abstracts [40 (3), 1997], over 500 papers were reviewed, and more than 1 in 15 of them made reference to either yield stress or plasticity.

1.2. The meaning of yielding

A typical dictionary definition of the verb ‘to yield’ would be ‘to give way under pressure’ and this implies an abrupt and profound change in behaviour to a less resistant state. As a *qualitative* description of a *general* change in the mechanical response of a material, it is completely satisfactory and unobjectionable, since many materials show a radical transformation in flow (or deformation) behaviour over a relatively narrow range of stress, and have obviously ‘yielded’, for example as seen in Fig. 1 where the flow properties of a 6% suspension of iron oxide in mineral oil (redrawn from [2]), change from a very viscous liquid ($\sim 10^5$ Pa s) at low stresses (~ 0.7 Pa) to a quite mobile liquid (0.5 Pa s) at a slightly higher stress (~ 3 Pa).

Historically this kind of behaviour was graphically portrayed in *linear* plots of applied stress against shear rate, which is not surprising, given the limited shear-rate ranges available—typically $1\text{--}100\text{ s}^{-1}$. However, plotted as, say, the *logarithm* of viscosity against the *logarithm* of applied stress, the phenomenon is much better illustrated. Within the limited range of measurable shear rates, it *looked as though* the viscosity of such a ‘yield-stress’ liquid was increasing asymptotically as the applied shear stress was decreased. Indeed, for all *practical* purposes it looked as though there was a definite stress where the viscosity did become infinite, see for example Fig. 2 which is derived from Fig. 3.8 of Han’s book [3]. Looking at it the other way

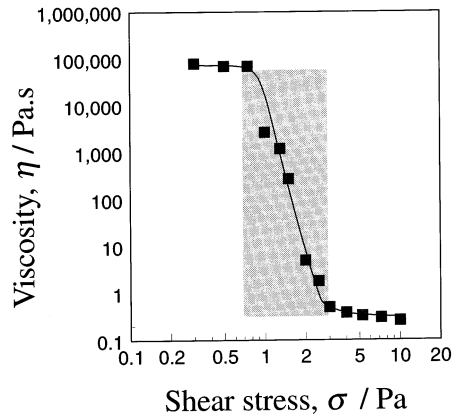

Fig. 1. Viscosity/shear-stress data for a 6% (by volume) suspension of iron oxide dispersed in mineral oil, replotted from Macosko [2]. Note the very large (10^5 -fold) drop in viscosity over a small range of shear stress, as shown by the shaded area.

around, below this critical stress the material in question appeared to be an infinite-viscosity solid, and above the critical stress, a (very shear-thinning) liquid!

The controversy begins here, since many people would then go on to strictly define a solid as a material that *does not flow*, i.e. continue to deform under stress. Hence, for them, below the yield stress there is no flow! This came about because those involved truly could *not* measure any sensible flow below the yield stress, that is to say, within the experimental means at their disposal at the time. The position taken here is that such experimental limitations have now been removed, and the picture has changed profoundly. However, without any further hesitation, we can say that the *concept* of a yield stress has proved and, used correctly, is still proving *very* useful in a whole range of applications, once it is properly defined, delimited and circumscribed.

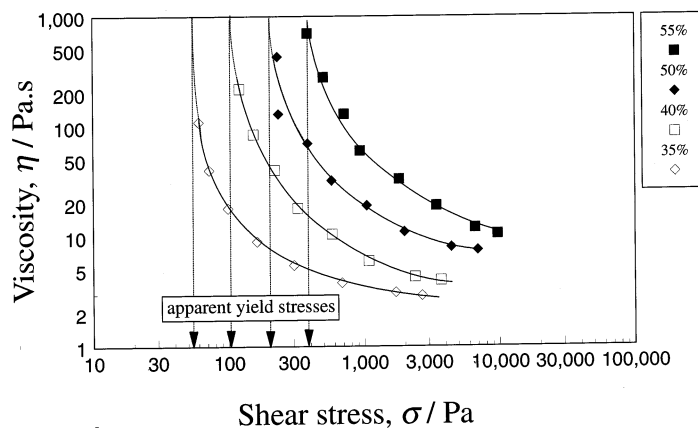

Fig. 2. Data replotted from Han [3] for low molecular weight polybutene (Indopol L100) loaded with glass beads at various volume% as shown, with the values of the apparent yield stresses indicated.

1.3. Yield stress and metals

Obviously, the idea of a yield stress was well imbedded in the domain of metals long before it was brought over into the liquids area by Schwedoff and Bingham early in this century. Indeed, the Bingham model was introduced in one of his books in 1922 in a chapter headed ‘The Plasticity of Solids’. (The original publication of the Bingham equation was in 1916 [4].)

However, the definition of the yield stress of a solid (for instance a metal) is itself far from being simple and easily described, and before we embark on a study of the subject for liquids, it is well worthwhile devoting some space to this topic. For instance, looking at some popular definitions offered nowadays, we have: Penguin Dictionary of Physics [5]:

“*yield point*—a point on a graph of stress versus strain... at which the strain becomes dependent on time and the material begins to flow.

yield stress—the minimum stress for creep to take place. Below this value any deformation produced by an external force will be purely elastic.

yield value—the minimum value of stress that must be applied to a material in order that it shall flow”.

McGraw-Hill Dictionary of Science and Technology, 4th Edition [6]:

“*yield point*—the lowest stress at which strain increases without increase in stress.

yield strength—the stress at which a material exhibits a specified deviation from [linear] proportionality between stress and strain”.

Chambers 21st Century Dictionary [7]:

“*yield stress*—the level of stress at which substantial deformation suddenly takes place.”

Chambers Dictionary of Science and Technology [8]:

“*yield stress*—the stress at which a substantial amount of plastic deformation takes place under constant load. This sudden yielding is characteristic of iron and annealed steels. In other metals, deformation begins gradually...”

Van Nostrand’s Science Encyclopaedia, 5th edition [9]:

“*yield stress*—the minimum stress at which a... material will deform without significant increase in load... some materials do not have a well-defined yield point and in others it is not a well-defined value.”

Clearly the definition is quite varied even within this small sample of everyday science publications: for instance, at one point it is ‘departure from linearity’; then ‘increase in deformation without increase in stress’ and then ‘the onset of creep or flow’, etc. Secondly, it is hedged about by all kinds of non-quantitative qualifiers, such as ‘specified deviation’, ‘substantial deformation’, ‘substantial amount’, ‘without significant increase in load’, ‘not... well-defined’, etc. All of this is in contrast, for instance, to the Young’s modulus of the same material, which is a well-specified quantity, which can be assigned precisely.

However we could say that a simplistic definition of the yield stress of a solid is essentially the point at which, when *increasing* the applied stress, the *solid* first shows *liquid*-like behaviour, i.e. continual deformation. If this is the case, then we can say that conversely, a simple definition of the yield stress of a *liquid* is the point at which, when *decreasing* the applied stress, *solid*-like behaviour is first seen, i.e. no continual deformation.

1.4. Liquids with apparent yield stresses

The liquids that appear to have a yield stress are legion. Among them are Bingham's many original examples such as clay, oil paint, toothpaste, drilling mud, molten chocolate, etc., then later, materials as diverse as creams of all sorts, ketchups and other culinary sauces, molten filled rubbers and printing inks, etc., were found to show similar behaviour. Now such disparate systems as ceramic pastes, electro-viscous fluids, thixotropic paints, heavy-duty washing liquids, surface-scouring liquids, mayonnaise, yoghurts, purees, liquid pesticides, bio-mass broths, blood, water-coal mixtures, molten liquid-crystalline polymers, plastic explosives, foams, rocket propellant pastes, etc., can be added to the extensive list.

In the following sections, we will trace the history of the subject and then look at the present position with regard to these kinds of materials in order to see where there is use and abuse of the yield-stress concept.

2. A historical survey

2.1. Bingham's yield stress and plasticity

Professor Eugene C. Bingham has left his name indelibly in the area of Rheology. His most conspicuous contributions were in the defining of the word Rheology (see chapter 1 of [10]) and commencing the first society of Rheology (and also being its journal's first editor), but he also endowed us with one of Rheology's most memorable and enduring non-Newtonian laws—the Bingham model or equation, with its 'Bingham' yield-value and plastic viscosity, which over the last dozen years or so has been used many more times than any other flow law containing a yield stress. Of course, the *idea* of a yield stress has been attributed first to Schwedoff in connection with experiments on gelatine solutions reported in 1900 [11], see Kramer and Williamson [12]—Bingham's later innovation was his simple intercept-with-straight-line law. In some Eastern European literature, the model is called the Bingham-Shvedov law, with its local variant of the spelling.

Although published earlier [4] (while working on English china clay suspensions), Bingham described his ideas at length under the heading of 'The Plasticity of Solids', in chapter 8 of his book 'Fluidity and Plasticity' [13] published in 1922. He presented a figure entitled 'Flow-shear diagram of a plastic solid', represented here as Fig. 3. While showing the normal straight-line portion with non-zero stress intercept, he also included a curved, lower portion near the stress axis that falls away from the straight line, conceding that, 'Unless the conditions of flow are carefully chosen... the amount of shear is not a linear function of the shearing stress. This departure from linearity is very often shown at the low rates of shear as indicated... by the curve FG. This peculiarity is not fully understood at present and the worker will do well to avoid anxiety in regard to it by choosing the conditions as nearly ideal as possible, so that the flow will be a linear function of the shearing stress. Nevertheless the cause of the above peculiarity must be investigated in detail if we are to understand fully the nature of plastic flow... Fortunately by using the higher rates of shear, we can apparently always obtain the simple linear relationship. If later experiments prove that this is not the case, it will be time to use the more complex

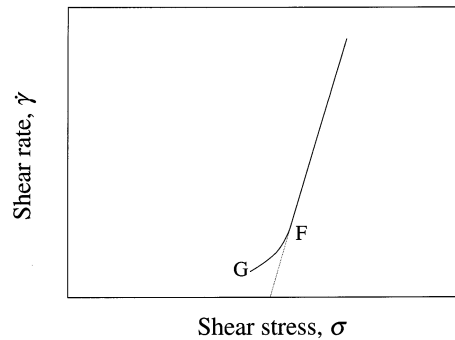

Fig. 3. A schematic representation of Bingham's original plot of shear stress versus shear rate, showing the region (FG) of departure from straight-line-with-intercept behaviour.

formulas' [13]. Of the results by Simonis on the flow of Zettlitz earth in water with curvature away from the straight line at low flow-rates he said 'the curvature is probably due to seepage'.

He went on to introduce the idea—well-used later—that 'paint must have a yield (stress) value high enough so that it will not run under the influence of gravity but the mobility (i.e. fluidity) must be high enough so that the painter may spread it without undue fatigue'.

It is also worth noting here that Bingham also discussed the flow of apparent solids after dealing with plasticity, listing work on pitch, asphalt, sealing-wax, marine glue, and many metals and alloys. This will come up again as we consider recent advances in the measurement of the creep of solids.

2.2. Marcus Reiner's contribution

Marcus Reiner, Bingham's erstwhile colleague, explained how doubts were first cast on the universality of the simple Bingham straight-line description of non-Newtonian fluids, and that his equanimity about the curved portion of the flow curve was not well founded. In his 'Ten Lectures on theoretical Rheology' [14], Reiner recounts that: 'Bingham originally found that the simple straight-line-with-intercept type description worked well for clays, oil paints, toothpaste, drilling mud, chocolate etc., all of course over very limited ranges of shear rate... After Bingham's success in explaining the viscosity anomalies of oil and clay suspensions, it was thought that this was the correct explanation in *every* case where a liquid showed variability of an apparent coefficient of viscosity. However, Bingham himself found that the consistency curve of a gelatine-water sol or a nitro-cellulose solution certainly did not follow his equation, and, as he remarked, 'the difference seems to be not one of degree, but to constitute a different class entirely'. The consistency curve could clearly be extrapolated towards the origin from which it evidently started at a definite slope; it had a continuous curvature, which gradually diminished. There was *nothing* to reveal a yield point. Bingham and his school still regarded this as another type of plastic flow, and to distinguish them from materials following Bingham's law, the materials of the 'second type' were called 'pseudo-plastics'. Only after some time was it realized that as there was *no yield point*, these materials were true liquids even with variable viscosities and at the first Rheology Meeting (1928), I proposed to call them 'Non-Newtonian Liquids' (*italics are mine*).

Even then, workers were very keen to hold on to the simple, straight-line-with-intercept/yield-stress concept and its easy-to-understand, two-term mathematical form. In passing we also note that the now-archaic term ‘pseudoplastic’ was in fact a misnomer. However, it still continues to be used very frequently in the literature, being cited in over 350 papers in the last dozen or so years, even though its use is deprecated in standard rheological glossaries [10].

In his later book, *Deformation Strain and Flow* [15], Reiner stated that ‘... we have described how Bingham came to consider oil paint to be a soft solid and not a liquid... [and] we reported that Jeffreys regarded the rocky shell of the earth as a very viscous liquid and not a solid. The difference between solid and liquid is therefore only one of degree. We can say with Heraclitus—*παντα ρει*—everything flows if given enough time; and with the prophetess Deborah ‘the mountains flow before the Lord’ would mean that they flow if the time scale of observation is extended to geological scale. Using [an] every-day time-scale we can define a solid as a material which either does not flow or flows *plastically*. Plastic flow requires a stress larger than a definite stress, the yield stress, and a plastic solid *does not* flow under the action of a stress *below that yield stress*¹. The limiting stress below which the material does not flow may be quite low: this makes a soft solid. Such a soft solid may be mistaken for a liquid for a long time, as was the case with oil paint, (N.B. *italics are Reiner’s*).

He went on in his general discussion of creep to quote Lord Rayleigh, who had calculated the viscosity of glass at room temperature to be 4.6×10^{19} Pa s from creep measurements, and adds that ‘*creep meaning here slow viscous flow*’. From such considerations, which usually treat glass as a solid, but where a finite viscosity can be measured, he noted that ‘the strictly defined rheological divisions belong to ideal abstract bodies and not to real materials’, p. 158. He then stated that creep in metals below their yield stress was first properly observed during the first world war, and was initially described in England by Faber in 1928. Then he commented perceptively that ‘a creeping material has no yield point: it creeps under the smallest load’. Thereafter, he recounted Bingham telling him about seeing a horizontal marble slab on a grave in Rock Creek Cemetery in Washington USA, supported by four short posts. He observed that the marble slab (~ 1800 mm long and 50 mm thick) had sagged ~ 80 mm over a time scale of two or three generations, and he asked in 1932, ‘Does the flow of marble continue indefinitely or stop, and is it directly proportional to the shearing stress?’. He and Reiner performed experiments on such stone materials and found viscosities in the order of 10^{16} Pa s. Finally, we record his comment that ‘seemingly solid materials such as pitch, bitumen, concrete, glass and metals may show an exceedingly slow continuous deformation: this is called creep’.

2.3. Houwink’s pre-war review of yield stress

Houwink contributed a 55-page chapter on the subject of yield stress to *The Second Report on Viscosity and Plasticity* published in 1938 [16]. What is unique about the contribution is that it considered yielding of solids and liquids together, and his discussion included crystalline solids, amorphous solids and suspensions. He first noted the difficulty in defining yield stress, ‘The phenomena exhibited by a substance as soon as non-elastic deformations make their appear-

¹ There may, however, be a relaxation of the yield stress which brings with it a flow.

ance, mostly are of a very complicated character; it is, therefore, not strange that often differently framed descriptions have been given of these phenomena, and that in formulating relationships and definitions, attention sometimes has been focused more upon one side, sometimes more on the other side. In particular sufficient harmony at times appears to be lacking between points of view developed in the technology of metals, and, on the other hand, points of view developed in connection with the investigation of those substances which in their properties seem to stand between pure solids and pure liquids. Various definitions of the notion of yield stress in consequence are to be found in the literature. It would appear at present a too ambitious task to attempt to frame a statement which might cover all cases that actually occur...'. When discussing solids he made the very useful statement that when the stress exceeds a certain value, 'the deformational motion of the substance under these conditions generally will be denoted as *'creep'*. In the special case where it occurs at a constant rate, independent of the time, we will use the term *'flow'*. This definition will prove very useful later when we come to discuss flow/no-flow situations. He then pointed out the difference between a yield stress defined as the first appearance of non-elastic deformations and that due to Bingham who said 'The yield stress is the minimum shearing stress... required to produce continuous deformation in a solid'. The complications alluded to earlier he then defined as mainly due to thixotropy.

Houwink then defined three possible apparent yield stresses that could be seen in flow curves, the upper yield stress, where the decreasing flow curve stops being linear (and hence where the simple Bingham formulation fails); the extrapolated value arrived at from that linear curve (the Bingham value), and the lower value, where the experimental flow curve *appears* to intersect the stress axis. He went on to say that 'it has been a matter of discussion sometimes in how far it is possible to measure the yield value of a substance... lack of sufficiently precise experimental data usually is the principal handicap. In the first place it is often a matter of great difficulty to determine exactly at which value of the stress, plastic (i.e. non-elastic, (unrecoverable)) deformation appears 'for the first time'. More refined methods of investigation may lead to the detection of plastic deformation at lower values of the stress'.

He then discussed atomic diffusion as a mechanism for creep, and used the Eyring rate theory to predict flow in solids below the yield stress. He eventually quoted the data of Chalmers, who very carefully measured the creep of single crystals of very pure tin (Fig. 4). Chalmers had found a linear creep region with a viscosity $\sim 2.5 \times 10^{15}$ Pa s and an abrupt down-turn into a very non-linear region. He then quoted Chalmers as saying that the stress corresponding to the critical region, where departure from linearity took place, would have registered as a 'yield value' by less sensitive methods, whereas the more sensitive method used by him revealed the occurrence of the linear (i.e. Newtonian) creep regime for stresses below the apparent yield stress.

In his comments on 'plastic behaviour and yield value of crystalline substances', he remarked that 'our starting point has been that plastic deformation is possible when there are regions of imperfections in the lattice structure, where atoms can jump from one equilibrium position to another. Strictly speaking, such effects can take place at all temperatures, and, theoretically, creep should be possible under any stress, however small!' These words are truly prophetic when we later come to consider the recent understanding of the creep of solids, soft solids and structured liquids.

2.4. George Scott Blair on yield stress and plasticity

Yield stresses also take us into the realm of plasticity, where the idea of flow above a critical stress has widespread applicability in many areas, spanning many materials other than those traditionally considered as liquids, albeit non-Newtonian. Indeed there is a natural progression from materials yielding and showing plasticity into non-Newtonian flow, and early conferences on the subject took that very name into their titles (e.g. Bingham's 1922 book entitled 'Fluidity and Plasticity' [13]). In fact, it was at the third *Plasticity* Symposium held in 1928 (under the auspices of the American Chemical Society) that it was decided to start the first *Rheology* society, and the first International Congress on *Rheology* did not take place until 1948 (at Scheveningen in the Netherlands) [17] following the earlier international Plasticity Symposia.

As always, we can turn to George Scott Blair's writings [17] for a suitable historical perspective on a subject like plasticity. He defined a plastic as 'a material which shows two remarkably different modes of behaviour under small and under large stresses respectively. Under the former it does not deform appreciably, the stress being taken up by elastic elements of high modulus; under high stresses it flows like a liquid'. Then he goes on to quote an early version of a Society of Rheology definition—'A plastic solid is one which obeys the law of an elastic solid for shear stress below the yield-stress, and for shear stress in excess of this value is permanently deformed without further increase in the shear stress'. Therefore, 'a plastico-viscous solid differs from a plastic solid in that, above the yield-stress, it deforms continuously at a rate of shear which is a function of the shear stress'. (Note that yield stress, yield value and yield point were all originally hyphenated). Scott Blair stated that he was himself confused as to the difference, claiming that no satisfactory definition had yet appeared anywhere in the literature. He then embarked on a long and tortuous chronicling of the different views of plasticity. For our purposes, we need only note that much of the complexity arose—and still arises—because of the multivariant nature of mechanical response, the stress being often made up of non-linear functions of strain, strain rate and time. He reproduced the British Rheologists' Club (the forerunner of the present British Society of Rheology) definition of nine typical kinds of

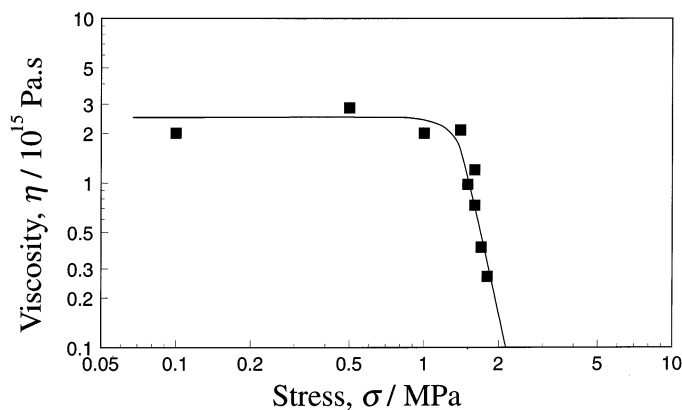

Fig. 4. Chalmers data [16] on the creep behaviour of high purity (99.996%) single tin crystals at room temperature, replotted as viscosity versus stress.

rheological response [18], of which two are of concern to us. The first is *plastico-elastic*, which allows for stress relaxation after stressing, second is *plastico-inelastic*, where there is no stress relaxation, while both of these were differentiated from Bingham-type behaviour which described *linear* response above a yield stress!

2.5. Andrade's thoughts on solids and liquids

Professor Andrade was Quain professor of Physics at the University of London: his work is an interesting bridge between solids and liquids, since he did much work on the creep of metals, but also worked on suspensions and gels. He moved easily from the continuous deformation of metals to liquids. In his 1947 book, *Viscosity and Plasticity* [19], he defined flow as ‘any kind of deformation under stress that increases with time’ and went on to say that ‘Every real body yields under stress’, but that ‘under suitable conditions of stressing nearly every solid will flow’. He then went on to talk about situations where steel, pitch, glass etc., would all show liquid-like behaviour under certain conditions. His most memorable example is that a glass rod ~ 1200 mm long and 5 mm diameter, supported at both ends, sagged ~ 5 mm in 5 weeks at room temperature. In his chapter on the flow of solids, he comments on Bingham's hypothesis of an ideal (straight-line-with-intercept) plastic that ‘it is doubtful if any body shows this behaviour’, noting that ‘the yield value is not sharp: between the region of perfect elasticity and the region of flow, there is a region of imperfect elasticity, where the body shows a delayed and imperfect recovery’. He did extensive work on soft metals such as lead and cadmium. These showed steady flow in tension after long-enough times, and these times to steady flow decreased with increasing stress. If the eventual steady-state viscosity is calculated from these data, then a power-law relationship between viscosity and stress is found for the region he studied. We will later make great use of data collected at even lower stresses, where Newtonian behaviour is seen.

2.6. Early post-war Rheology conferences

One of the first important post-war Rheology meetings was reported in 1954 in ‘Rheology’, edited by Harrison [20]. In the conference proceedings, one of the lowest shear-rate experiments to date was reported on plastic solids, when Geuze and Tjong-Kie [20] showed shear rates as low as $\sim 10^{-10} \text{ s}^{-1}$ on a sample of clay. If these results are replotted onto logarithmic axes, we see that clay continued to creep down to shear rates as low as 10^{-10} s^{-1} in a power-law fashion, with no suggestion of a yield stress. In the next article, almost identical behaviour was seen for zinc, measured in penetration for very long times. Bondi [20] then presented data on acetylene black in medicinal white oil, which showed an apparent yield stress, but only when data in the range $2\text{--}40 \text{ s}^{-1}$ were used, and then they spoke about *two* yield stresses, one ‘at very small displacements not easily measurable... and the yield stress characteristic of gross deformation’. Hutton and Matthews [20] extended the original work of Vinogradov on greases back into the linear region, where the viscosity of petroleum jelly was found to be Newtonian below a certain value. They indicated that the departure from this linear region above a critical stress defined a ‘yield stress’. They performed compressive creep tests over a time-scale of $3\text{--}86400 \text{ s}$, and were then able to detect enough creep to produce sensible values of steady-state flow parameters. The yield stresses for sodium- and lithium-based greases were 800 and 550 Pa, respectively, both having finite but very high Newtonian viscosities at stresses below these values.

In the Proceedings of the British Society of Rheology Conference in 1957 (the first major Rheology conference to be held in Wales) [21], out of the 11 published papers, more than half routinely used the concept of yield stress to characterise their findings. Casson presented his theory for suspensions, in which he produced a now-classic equation (which bears his name) based on simple microstructural concepts. The equation is akin to Bingham's, but both the shear rate and shear stress appear in square-root form. However, the straight-line-with-intercept form is the same. Also, Bantoft (then an ICI colleague of Casson) tested Casson's equation on a series of pigment-plasticiser dispersions, and showed that while the Bingham model worked reasonably well over a shear-rate range of 50–150 s⁻¹, Casson's equation better described the flow curve of most of the pastes tested from ~4–100 s⁻¹. At the same time, Eveson presented work on the 'Viscosity of stable suspensions of sphere at low rates of shear', where then low meant 0.15 s⁻¹!

Dukes described work on 'Rheological measurements on Lutings', which are soft plastic and adhesive materials used for sealing and waterproofing screw-threads, typically synthetic waxes in low molecular-weight polyisobutene, and measured in a parallel-plate, compressional plastometer. Yield stresses could be measured via the minimum thickness attained when a weight is loaded onto the plates. (He quoted Peek, who had measured the yield stress of Plasticine™, the 'standard' soft-solid, by this method and found it around ~10⁴ Pa, see later for a lengthier discussion of this interesting material.) Dukes noted that this method was better than extrapolating pipe-flow results, because 'laminar flow at medium shear rates tends to change into plug flow at very low rates of shear'! The expression used for the calculation of yield stress in a parallel-plate plastometer was

$$\sigma_y = \frac{Wh_e^{5/2} \pi^2}{2V^2}, \quad (1)$$

where W was the weight applied, V the volume of the sample, and h_e the equilibrium distance between the plates. The plastic viscosity, η_p , could also be calculated, using the speed of approach of the plates.

Finally, Lenk showed that starch-clay coatings could be characterised by a 'yield value', and Steiner showed similar flow curves for molten chocolate, which although they showed a poor fit to the Bingham model, nevertheless the extrapolated Bingham yield-stress values were quoted for a range of chocolate formulations, typically from 3 to 40 Pa.

2.7. Sherman's contribution to yield stress in Industrial Rheology

Sherman [22] pointed out that 'the use of 'yield value' has been extended in recent years... to define the inflexion point in a plastic flow curve. The intercept on the [stress] axis which is obtained by extrapolating the linear portion of the curve is termed the extrapolated yield stress. The value [of stress] at which linear flow commences is called the upper yield stress'. He then described ways of measuring the yield stress of soft solids, and lists the following values of yield stress and their everyday significance for food-like materials:

~ 5000 Pa	Very soft just pourable
5000–10 000	Very soft, not pourable
10 000–20,000	Soft, but already spreadable
20 000–80 000	Plastic, and spreadable
80 000–100 000	Hard, but satisfactory spreadable [sic]
100 000–150 000	Too hard, limits of spreadability
> 150 000 Pa	Too hard

These values were obtained using cone penetrometry, by noting the depth to which a loaded cone entered into the material, but measured over a *short* time period. It is interesting to note that at the same time one of Sherman's specialities was the measurement of the *long*-term creep properties of soft solids like butter, margarine and ice-cream, which, while fitting the above description of a material with a yield stress, nevertheless had a Newtonian creep viscosity *below* the yield stress! For instance, his ice-cream viscosities were in the order of 10^8 Pa s. He quoted earlier measurements of the viscosities of various English cheeses in the range 10^{10} – 10^{11} Pa s, and for concentrated oil-in-water emulsions with 65% w/w disperse phase, the creep range had viscosities of over 10^6 Pa s. He even measured Madeira cake and came out with viscosities of $\sim 10^9$ Pa s! These kinds of numbers can be compared with the more recent work of Harnett et al. on the creep of butter [23], who found values of the steady-state creep viscosity at 10°C to be in the range 24 – 11×10^{10} Pa s. Similar creep measurements were made on various kinds of solid soap by Pacor et al., who found values of creep viscosity depending on formulation and moisture content in the range 5 – 160×10^{11} Pa s after 1.5×10^4 s of creep [24].

2.8. Wilkinson's use of yield stress in his standard text

Wilkinson [25] is a very good example of an author who took a typically pragmatic, uncomplicated view of flow curves for process engineering purposes, listing simple flow equations uncritically as far as yield stresses were concerned, and defining a Bingham plastic as a flow curve with an intercept defining the yield stress, which is said to be the stress that must be exceeded before flow starts. However, he then went on to define the slope of the curve not only as the plastic viscosity, but also strangely as the coefficient of rigidity. He said that 'the concept of an idealised Bingham plastic is very convenient in practice because many real fluids closely approximate this type of behaviour. Common examples are slurries, drilling muds, oil paints, toothpaste and sewage sludge'. He then proceeds to an overly simplistic explanation that 'if this [yield] stress is exceeded the structure completely disintegrates... When the shear stress falls below... [the yield stress] the structure is reformed'. He goes on to show that for flow of a Bingham plastic between widely spaced concentric cylinders, at large stresses (i.e. where $T > 2\pi\sigma_y r_2^2$), the rotation rate ω (in revolutions per second) is given by

$$\omega = \frac{T}{4\pi\eta_p} \left(\frac{1}{r_1^2} - \frac{1}{r_2^2} \right) - \frac{\sigma_y}{\eta_p} \ln \frac{r_2}{r_1}, \quad (2)$$

where T is the couple per unit height of the cylinder; r_2 and r_1 are the outer and inner radii of the cylinders, respectively. He then showed that by plotting T against ω , the values of σ_y and η_p could be found [26].

Wilkinson also quoted Buckingham's well-known expression [27] for the flow of a Bingham plastic in a pipe

$$Q = \frac{\pi a^4 \Delta P}{8L\eta_p} \left[1 - \frac{4}{3} \left\{ \frac{2L\sigma_y}{a\Delta P} \right\} + \frac{1}{3} \left\{ \frac{2L\sigma_y}{a\Delta P} \right\}^4 \right], \quad (3)$$

and goes on to point out the helpfulness of the non-dimensional group worked out by Hedstrom [28]:

$$H = \frac{4\sigma_y \pi a^2}{\eta_p^2}, \quad (4)$$

which has been used with the Reynolds number to predict graphically the flow of Bingham plastic materials in pipes. This is now superseded by computer-based numerical methods. He also points out Weltmann's analysis [29] for flow in a pipe, where

$$R_e = \frac{2au_m \rho}{\eta_p}, \quad (5)$$

u_m being the average velocity, and then in the well-known form of the friction-factor equation:

$$c_f = \frac{16}{R_e} \cdot \frac{p}{8c}, \quad (6)$$

where u_m is the average velocity, $Q/\pi a^2$, c is the ratio of the yield stress to the wall shear stress ($2\sigma_y L/a\Delta P$), and p is the plasticity number given by

$$p = \frac{2\sigma_y a}{\eta_p u_m}. \quad (7)$$

2.9. Final comments on a historical review

This section can be brought to a proper close by referring to the seminal work of Bird, Dai and Yarusso in 1982 [30], which presented the most extensive review to date on the subject of yield stress liquids, listing over 200 papers, and covering 'useful empiricisms', 'the stress tensor in arbitrary flow fields', 'some analytical flow solutions for the Bingham model', 'some analytical heat-transfer solutions for the Bingham model', 'summary of flow problems', and a 'summary of heat-transfer problems'. At the time, they complained that 'recent textbooks and monographs on rheology and continuum mechanics have devoted little or no space to the subject [of viscoplastic materials]'. However, at the same time they also called attention to 'the series of eight carefully written publications by Oldroyd [31], which included the formulation of viscous-flow problems, boundary-layer theory of slow motions, and illustrations of methods of solution of non-trivial problems, both without and with time-dependence'. In their conclusions they comment that 'the Oldroyd papers... have really not been exploited. There remains much to be done in getting nontrivial solutions for viscoplastic flows and the Oldroyd papers should be used

as a point of departure'. They tabulated extensive lists of flow problems studied for the Bingham, Casson and Herschel-Bulkley models as well as some others. Their listings of papers that relate microstructural features of suspensions to yield stress are still very useful.

Before the great changes brought about by the advent of the new generation of controlled-stress rheometers in the early-to-mid-1980s, it is possible to conclude that the idea of a yield stress was well accepted in the rheological world as a proper description of some structured liquids, especially flocculated colloidal dispersions and the like. While simple polymer melts and solutions were, by the late 1970s, well described by a 'simple' flow curve of low shear rate Newtonian plateau-power-law shear thinning-high shear rate Newtonian plateau, this was obviously not the case for what were considered at the time to be 'structured' liquids. (In fact the present author embarked upon a career in industrial rheology in 1970 with this firmly in mind, blithely accepting and using the concept of a yield stress as a proper material parameter and beginning to measure it with enthusiasm.) At the same time, much evidence was accumulating to prove that even though an apparent yield stress could be measured, creep existed below this stress, and in some cases the creep/flow at very low stresses showed Newtonian behaviour.

3. The present situation

3.1. Introduction

We shall, somewhat arbitrarily, define 'The present situation' as 1985 and onwards, following the appearance of the Barnes and Walters' paper, 'The yield stress myth?', (an earlier version of the paper was given at the 9th International Congress on Rheology, Acapulco, October 1984, [32]), and the widespread debate that ensued. Of course we could also say that this date marks the point when results of complete flow-curve measurements from controlled-stress rheometers were becoming readily available, so that the statements of Barnes and Walters could now be safely made, since this behaviour was being seen by more and more workers.

3.2. Summary of the Barnes and Walters' paper

Having pointed out that 'shear viscosity still maintains its position as the most important material function in an industrial context', Barnes and Walters went on to investigate the particular shape of the viscosity/shear-rate curve. They stated that in this context, the 'yield stress' hypothesis had long been accepted and considered useful, if not indispensable. They then anticipated their later argument by saying that the 'yield stress' is in fact an idealization, and that given accurate measurements, no yield stress exists. They briefly reviewed the history of the concept, and noted that already Scott Blair had said that the yield stress was 'that stress below which no flow can be *observed under the conditions of experimentation*' [*italics theirs*]. Then using two examples of materials typically thought to display 'yield stress' behaviour, they reported new results obtained on a controlled-stress rheometer for a commercially available PVA latex adhesive and 0.5% aqueous Carbopol solution. In both cases they saw the 'normal' shape of curve of viscosity/shear-rate in that the viscosity descended from a high-viscosity/very-low-shear-rate plateau, through a power-law region to a low-viscosity/high-shear-rate plateau (the

‘full’ Carbopol curve was shown later by Barnes [33]). They also showed that various parts of the data could easily be represented by a linearly plotted ‘yield-stress’ diagram, but where the indicated yield stress decreased as the range of shear rate used was decreased. They showed that the Cross model fitted the data very well, and then no yield stress component was needed.

3.3. *Some reactions to the Barnes and Walters’ paper*

The most serious challenge to the views propounded by Barnes and Walters came some four years later from Harnett and Hu [34]. However, they were very careful to couch their language in engineering phraseology: to them the yield stress was an *engineering* reality. That is to say, for all practical purposes, one could assume that a liquid had a yield stress when considering it on a reasonable length and time scale (who can argue with that?). The problem to them was—in the later words of Astarita [35] commenting on their falling-sphere experiment—‘how long a ball appears to be standing still’. To be specific, they studied the movement of small spheres falling in 2500 ppm aqueous Carbopol solution, using a photographic technique and found that a certain small nylon ball did not appear to move for several months. Unfortunately, given the very large viscosities involved, the observation would need to have been made using a microscope not a telescope.

Astarita [35] made some light-hearted comments about the debate, but noted seriously and sensibly that ‘whether yield stress is or is not an engineering reality depends on what problem we are considering’.

The present author himself commented on the paper [33] some seven years later, stating that the original work had by then been cited well over 30 times, and had created a lot of interest. He showed that, for suspensions, there might well be a yield stress, given that the particles did ‘jam up’ under certain circumstances, and that then they would not move (this of course is itself an oversimplification). An equivalent criterion could also be laid down for a flocculated suspension with a fractal floc structure. Apart from these situations, where apparent yield stresses are predicted (see below for details), the present author also commented that yield stresses were usually only a ‘figment of peoples’ extrapolation’, and experiments using more sophisticated apparatus showed that no real yield stress existed at all. In the same publication, Harnett’s work using a falling sphere was said not to be appropriate in the case of the very high viscosities being quoted ($> 10^7$ Pa s for 0.3% Carbopol at shear rates below 10^{-6} s $^{-1}$), or the equivalent stress.

Evans [36] raised some very philosophical points in a letter to the editor of the *Journal of Rheology* on the nature of the yield stress. While stating that the yield stress issue was ‘sparked off by Barnes and Walters (1985) in a thought-provoking article’, he noted that ‘this debate hinges on the meaning of the term ‘yield stress’ and mirrors a dispute between politicians who will not accept each other’s definitions. Thus, Barnes and Walters adopt the classical definition of yield stress as a stress below which, for a given material, no unrecoverable flow occurs. *Such a definition effectively rules out experimental proof of the existence of a yield stress*, should such exist, since it would require an infinite time to show that the shear rate, at any given stress, is actually zero. Disproof might also sometimes require inordinately long experiments... (emphasis mine). He then concedes that ‘it seems likely that most, and perhaps all, materials will undergo flow at any stress since flow merely requires the existence of a relaxation mechanism’. He went

on to say that ‘the availability of unoccupied locations within real structures, together with thermal energy fluctuations, must allow for such mechanisms... some may require very long time scales. The classical definition of yield stress thus seems to ‘define away’ the possibility of its existence’ [emphasis mine]. He then went on to define, and give practical examples of, a situation very near that described as possible by Cheng [37] (Eqs. (8)–(10)), where the stress in an intermediate range of shear rates almost becomes constant, but below this range it drops away towards a Newtonian-like behaviour. He says of such a behaviour that ‘the existence of an essentially horizontal region in a double-logarithmic plot of stress versus strain rate is the most satisfactory criterion for the existence of a ‘yield stress’...’. As we will show later, this author is in substantial agreement with Evans in this view, especially if then term ‘yield stress’ is prefixed with the adjective ‘apparent’!

Nguyen and Boger [38] reviewed methods of measuring the flow properties of yield stress fluids in 1992: those seeking detailed descriptions of such experimental methods are directed to this comprehensive work, the especial value of which is the emphasis on possible sources of error in measurement. In their general commentary on the yield-stress situation, they make the following helpful comments: ‘The controversy over the existence of the yield stress... is not new, but has persisted since the time Bingham... [who] discovered that paint was not a truly viscous liquid... It was pointed out... that flow property measurements for this class of fluid at low shear rates (or shear stresses) are more frequently affected by instrumental effects than those for simple liquids... measurements... usually produce conflicting results depending on the techniques employed, the criterion on which the yield stress is based, and often the patience of the investigator as well’. This statement is well worth pondering, for low shear stresses highlight slip effects (see Barnes [39]) and long time constants more than any other situation.

One interesting contribution to the debate was provided by De Kee and Chan Man Fong [40]: they built up a model based on simple ‘structure points’ n , the rate of change of which with time dn/dt , as in the typical thixotropic theories, could be expressed by an equation with build-up and breakdown components. From this a yield stress is obtained in terms of a critical number of structure points, n_0 . They also predict a minimum time required for flow to be observed on the application of any particular stress, σ_1 . Based on this equation, with its inverse proportionality of time on stress, they make the interesting comment that ‘the measurement of the yield stress... is a measure of the experimenter’s patience’, since they predict that a very long time is needed to measure flow at very low stress.

Spaans and Williams [41] claimed ‘At last, a true liquid-phase yield stress’ in the title of their paper, and describe a theory and experiments on block copolymers, which suggest a yield stress, or rather a yield strain. They use an argument that begins with the well-known Eyring rate theory, based on the supposition that imposing a stress lowers the potential barrier of any molecular movement in the direction of the imposed stress, while raising the barrier in the opposite direction. This makes the probability of a random segmental jump become biased in the direction of stress: the outcome being that no matter how small the stress, there will always be a small but finite possibility of flow. However, to this they add the fact that in their picture of a block copolymer, any movement away from equilibrium in that system raises the chemical potential of a segment in a mixed interphase if flow and thus demixing takes place. This might seem a plausible argument, but surely this too becomes a probability function, like the normal argument, and would almost predict flow backwards. This author would not be happy with such

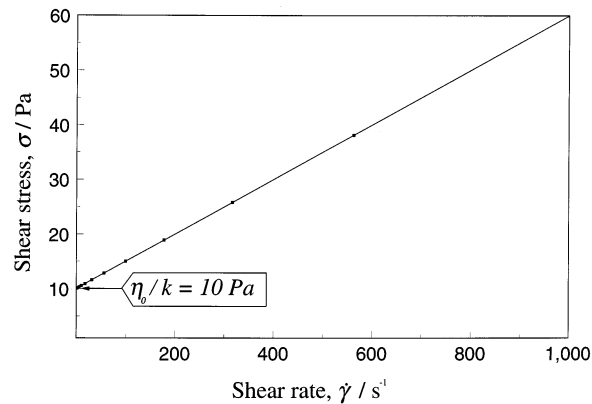

Fig. 5. Cheng's yield-stress concept liquid [37] effected using the Cross model with $m = 1$, for values of $\eta_0 = 10^6$ pa s, and $\eta_\infty = 50$ mPa s, plotted on a linear basis, showing the value of apparent yield stress as $\eta_0/k = 10$ Pa.

an argument until experiments have been performed, not in stress relaxation mode as by these workers, but by using a stress-controlled creep test over a very long time, and with a very sensitive discrimination of strain. It would be strange if this were the only material in the universe not to continually creep!

Earlier Cheng (commenting on the Acapulco version of the Barnes and Walters' paper) had made it clear that very often the magnitude of any measured yield stress depends on the time of the measurement. This is because viscoelastic and thixotropic effects can mask other features. In a special report [37] he says 'in a perverted sense, the yield stress is a time-dependent property'. One other interesting concept put forward by Cheng is the possibility in his mind of a hypothetical material that, as the shear rate was decreased, tended clearly to a constant stress, but at much lower shear rates it then decreased again, and eventually showed Newtonian behaviour. This idea is best illustrated by plotting the viscosity against the shear rate on a logarithmic basis, as he did (Fig. 5), but translating this to a plot of viscosity/stress is even more

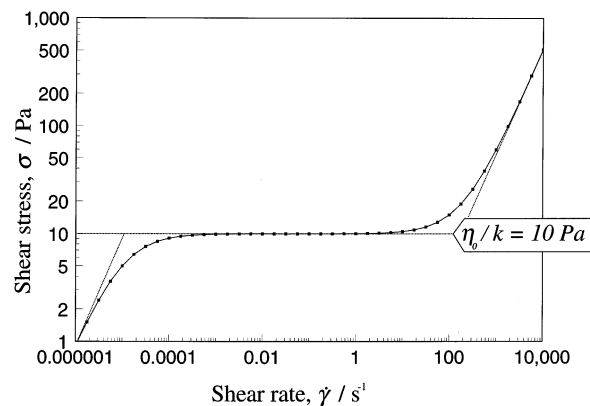

Fig. 6. As Fig. 5, but plotted on a logarithmic basis, and also showing the asymptotic Newtonian behaviour at very low and very high shear rates respectively as dotted lines.

informative, (Fig. 6). This concept, of course, satisfies the idea of having a real yield stress as well as having flow (creep) below this yield stress. Some materials come near to this idealism: the present author [33] later quoted results for a Carbopol solution, where the slope of the logarithmic plot of viscosity/shear-rate in the power-law region was -0.92 instead of Cheng's ideal value of -1 [37]; then below this region the viscosity tended towards Cheng's ideal Newtonian plateau.

If this concept is cast into the most non-Newtonian form of the Cross model, i.e. $m = 1$, it is easy to show that

$$\frac{\eta - \eta_{\infty}}{\eta_0 - \eta_{\infty}} = \frac{1}{1 + k\dot{\gamma}}, \quad (8)$$

which for structured liquids at high shear rates, i.e. $\eta_0 \gg \eta_{\infty}$ and $k\dot{\gamma} \gg 1$, simplifies to

$$\eta = \eta_{\infty} + \frac{\eta_0}{k\dot{\gamma}}. \quad (9)$$

This can easily be recast as the Bingham equation by multiplying throughout by shear rate, so

$$\sigma = \frac{\eta_0}{k} + \eta_{\infty}\dot{\gamma} \quad \text{or} \quad \sigma = \sigma_0 + \eta_p\dot{\gamma}, \quad (10)$$

where the Bingham-model parameters are the yield stress σ_0 , now given by η_0/k and the plastic viscosity η_p now given by η_{∞} .

3.4. Some recent definitions of and comments on yield stress

When recent authors attempted a more-than-simplistic definition of yield stress, they soon had to start qualifying their statements very carefully. Ferguson and Kemblowski [42] said that 'Yield stress is a limiting shear stress at which the material starts to flow (below the yield value the material behaves as an elastic solid)... In the literature doubts are often expressed whether the yield stress σ_y exists in reality... Such considerations are, however, of little importance from a pragmatic point of view as long as the Bingham or Herschel-Bulkley models describe adequately the rheological behaviour of many real materials... There is considerable doubt being cast, at present, on whether or not yield value exists. It does, however, represent a useful concept in structure forming systems... Constant stress viscometers provide the most direct method for making the measurement. Shear stress in the dispersion is progressively increased and no shear flow is detected until the yield stress has been reached. In practice it may be found that the method is at least partly subjective... Problems arise when the equilibrium curve does not become a straight line. Careful experimental work at very low shear stresses has shown that often flow still occurs even though the dispersion is of very high viscosity'.

Whorlow [43] recently commented that 'Strong but contradictory views about the nature of yield stress have been held in the past, partly because the importance of the characteristics of the instrument were not fully appreciated. Use of the relatively new controlled-stress rheometers, which allow the application of a constant small stress to a sample for an indefinite time, has resulted in further, but not complete, understanding of the subject... Barnes and Walters conclude that the concept of a yield stress is a myth', p. 14.

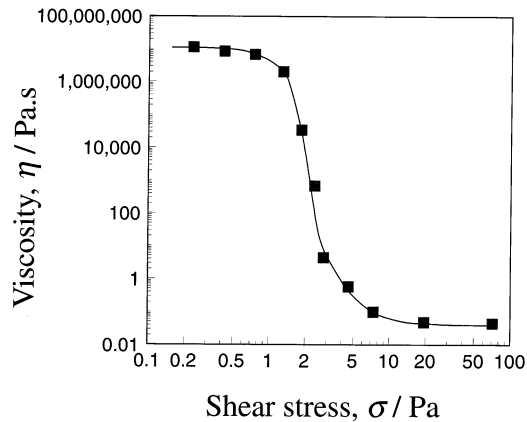

Fig. 7. Viscosity versus shear stress data for a 10% suspension of bentonite, replotted from Malkin [44].

Macosko [2] carefully hedges his definition. He says that ‘A plastic material is one that shows little or no deformation up to a certain level of stress. Above this yield stress the material flows readily’. He also concedes that ‘large errors in [yield stress] can result by picking the wrong range to fit the Bingham model’. His data on an iron-oxide suspension is most revealing (Fig. 1 is a replot of his Figure 2.5.4), since the stress eventually approaches a linear region at very low shear rates ($\sim 10^5 \text{ s}^{-1}$), as it also does at very high shear rates ($< 10^2 \text{ s}^{-1}$). When he replots these data, they show Newtonian plateaux at high and very low shear rates, respectively, and has no sign of a yield stress, saying that ‘there is a lower Newtonian rather than a Hookean regime!’ As we have seen, his data, when fitted to a Cross model (Fig. 1) show the good results over a very wide range.

Malkin [44] recently took a far more realistic view of the situation. He first shows some remarkable data for its time from Rehbinder’s Russian colloid group on a 10% aqueous Bentonite suspension, published in 1955, which is replotted here as Fig. 7 in our preferred viscosity/stress form. Malkin commented on the very sharp drop (about eight orders of magnitude in one decade of stress) in viscosity in a narrow range of stress which approximates to a yield stress. He went on to state that ‘it is reasonable to treat the behaviour of a material... as solid-like (even though the material is a liquid and flows even though its viscosity is very high)... [the drop] might be considered as a transition from solid-like to liquid-like behaviour’.

3.5. Modern-day measurements of very non-Newtonian liquids

The measurement of the response of a structured liquid at low stress has changed markedly over the last 20 years or so, since the introduction and improvement of controlled-stress rheometers, which are able to apply small stresses and measure *very* low shear rates. It is as a consequence of this progress that the idea of a yield stress has been seriously challenged (or in some quarters heartily defended!).

Originally, controlled viscometers (as opposed to static U-tubes and cups, etc.) were based on an applied *stress* which was generated by a weights-and-pulleys arrangement, as shown for instance in Fig. 8. However the limitations of this type of instrument in terms of attaining *low*

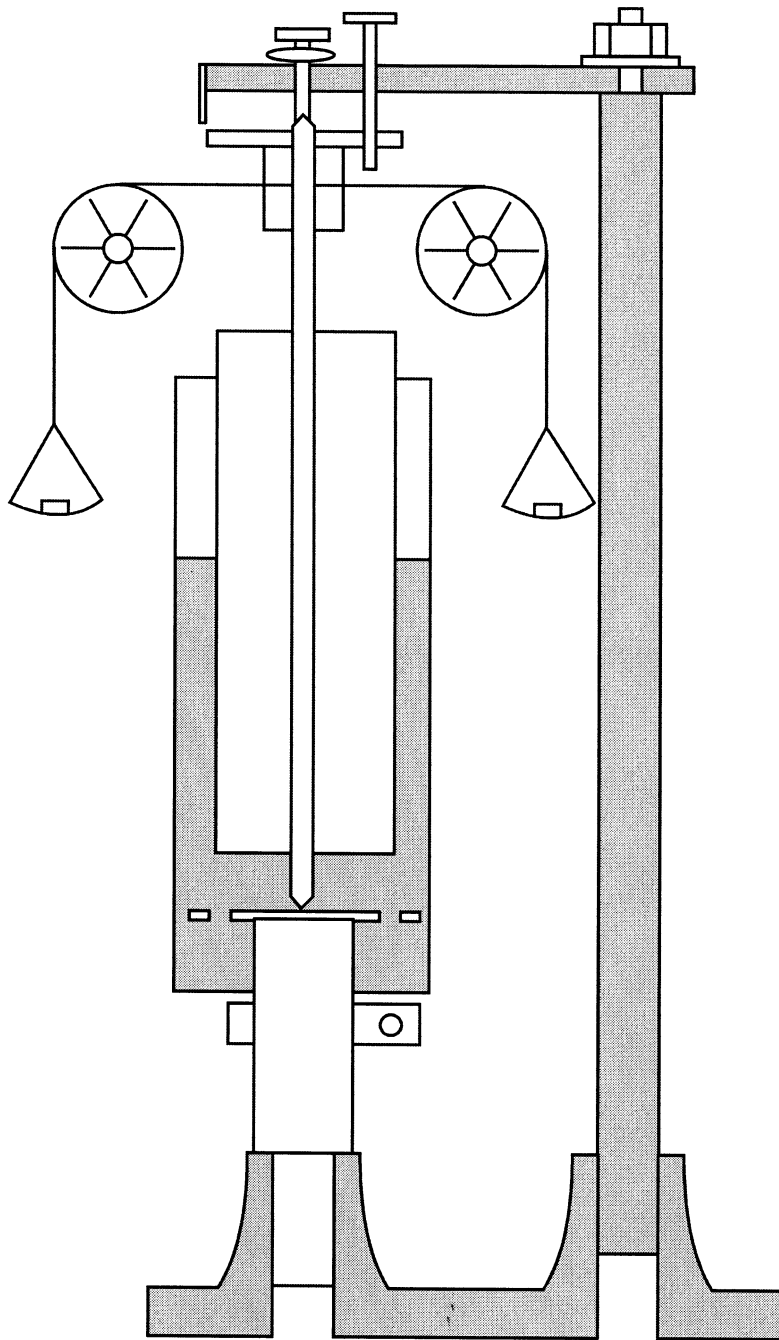

Fig. 8. A sketch of Searle's 1912 controlled-stress, concentric-cylinder viscometer.

shear rates due to bearing friction were soon found, as also where the limitations of prolonged shearing at *high* shear rates—the finite length of the string! These methods were then superseded by electrically driven motors and the (what we now call) controlled-strain instruments had arrived, largely replacing the controlled-stress variants. These became more and more sophisticated, and eventually with logarithmic mechanical gear boxes were able to span a shear-rate range typically from $\sim 10^{-4}$ to 10^4 s $^{-1}$ (e.g. the Weissenberg Rheogoniometer).

In the mid-1970s, a new generation of controlled-stress rheometers began to appear. The first had been developed by Deer and colleagues at the London School of Pharmacy [45], who used air bearings and an air-driven turbine to provide the torque. Ironically, the stated claim of those early air-turbine instruments was ‘The ability to investigate accurately the region around the ‘yield’ point is of the greatest importance in the study of the rheological properties of such materials. However, conventional viscometers in which rotation, or shear strain, is a fixed variable are quite unsuited to this purpose because yield point can only be determined in an instrument in which shear STRESS is the fixed variable’ [46]. It was also claimed was that ‘with such an instrument the application of a known and controlled stress provides the rheologist with vital information of this critical region in the form of a ‘CREEP’ curve’ [46]. These claims could be made because they had introduced a ‘specially designed air bearing... and an air turbine drive system for the application of torsional stress that is independent of rotational speed... throughout the operational range’. Air bearings and air turbines had been and still are used for dentists’ drills, but of course at much higher speeds, hence the whine! Air bearings had previously been used in rheometers, see Oldroyd et al. [47]. Using a pre-commercial version of the air-turbine rheometer in the creep mode, Davis et al. [45] found that the viscosity of wool fat BP at 25°C over a shear rate range of $1.76 - 6.14 \times 10^6$ s $^{-1}$ was constant (to within a small experimental error) at $\sim 2 \times 10^6$ Pa s.

Then around 1980, commercial versions of the new generation of electrically driven controlled-stress rheometers began to appear, still based on air bearings that greatly reduced friction, but now using so-called drag-cup electrical motors that allowed controlled stresses to be more easily applied, but still independent of rotation speed. Along with these features came new ways of measuring smaller and smaller rotation and rotation rates. The latest optical-disc technology now means that rotation rates as low as 10^{-8} rad s $^{-1}$ (~ 1 revolution in 20 years) can be measured! This has opened up a new range of previously unobtainable flow behaviour for structured liquids which *seemed* to have a yield stress. Access to these ultra-low shear-rate regions is now called creep testing, by analogy to the testing of solids under similar low-deformation-rate, long-time conditions; albeit solids creep testing is usually performed in extension rather than in shear.

Table 1 compares the specifications of some typical controlled-stress rheometers as they have evolved over the last thirty years or so. It is clear that an amazing increase in sensitivity and range has been brought about, especially in the lower-and-lower minimum torques (and thus stresses) and rotation rates (and thus shear rates) achievable.

Figs. 9–11 give some typical examples of the kind of results which have been obtained for very non-Newtonian liquids, which would previously have been thought to have a yield stress, but which now obviously conform to the simple Newtonian-through-power-law-to-Newtonian model. Note again the similarity of these results to the much earlier but seldom quoted work shown in Fig. 7.

Table 1
Some typical controlled-stress rheometer brochure specifications

Period	~ 1970	~ 1978	~ Early 1980s	~ Late 1980s	~ 1995
Typical instrument	Air turbine rheometer	Deer rheometer	Carrimed Mk1	Carrimed CSL 100	TA Inst. AR 100
Torque (Nm)					
Min.	10^{-4}	10^{-5}	10^{-6}	10^{-6}	10^{-7}
Max.	10^{-2}	10^{-2}	10^{-2}	10^{-2}	0.1
Resolution	10^{-4}	10^{-5}	10^{-7}	10^{-7}	10^{-9}
Ang. Veloc. (rads s ⁻¹)					
Min. (creep)	—	—	—	—	10^{-8}
Max.	50	50	50	50	100
Resolution	—	—	10^{-2}	10^{-4}	—
Creep (strain)					
Resolution	2×10^{-2}	2.5×10^{-3}	2.5×10^{-4}	10^{-5}	6.2×10^{-7}
Max.	—	—	—	—	1300

Data kindly checked by Mr Derek Bell of TA instruments.

3.6. Slip artefacts in rheometry mistaken for yield stresses

In a recent review, the present author [39] pointed out that because of various wall-depletion effects, the apparent flow curves for some non-Newtonian systems being measured in viscometers appeared to show a Newtonian plateau at low shear rates, with a further turn up in viscosity at even lower stresses, which under normal circumstances would indicate a yield stress. However, once the slip/wall-depletion effect had been removed, or corrected for, the flow curve returned to normal, with no yield stress, but a higher lower-shear-rate Newtonian plateau (Fig. 12). A number of authors have published results of this sought, but which were either corrected or contradicted by later work.

Mannheimer [48] showed that for concentrated cement slurries, once the effect of slip had been removed, the remaining results indicated a very shear-thinning fluid. If his results are replotted (logarithmically) as viscosity as a function of stress, then a very shear-thinning liquid is seen, with the beginnings of a curvature down towards an asymptotic value of η_{∞} . There is then no need to invoke a yield stress.

Notwithstanding what we have just considered, it is possible to find non-Newtonian liquids which would show a turn up from a Newtonian plateau, but which, if they were measured to low-enough shear rates, would again flatten out to a second and higher Newtonian plateau. Fig. 13 shows a hypothetical example of this behaviour. This doubly shear-thinning behaviour results from two distinct, but widely spaced shear-thinning mechanisms such as a flocculated suspension in a polymer solution with a relatively high shear rate departure from Newtonian behaviour. Of course if the whole curve were not available, and measurements were only made to the turn up from the intermediate plateau, the situation would again be mistaken for the existence of a yield stress.

3.7. The vane geometry

The vane geometry (where the vane is used instead of an inner cylinder of a viscometer/rheometer), with its diversity as to vane number and aspect ratio, has proved very popular for measuring very structured liquids with supposed yield stresses. It offers the possibility of inserting the vane into an existing rested or stored sample with the minimum of disturbance. Also, and more importantly, the vane geometry eliminates slip which is so common in structured liquids with apparent yield stresses. The vane geometry has been widely used to measure yield stresses in such diverse systems as

Bioengineering bio: masses: filamentous fermentation broths [49,50];

Particle suspensions: nuclear-waste slurries [51], oil-well cements [52], ironoxide suspensions [53], fly-ash slurries [54], mineral suspensions [55], titanium dioxide suspensions [56], ceramic suspensions [57,58];

Muds and clays: Bentonite gels [59];

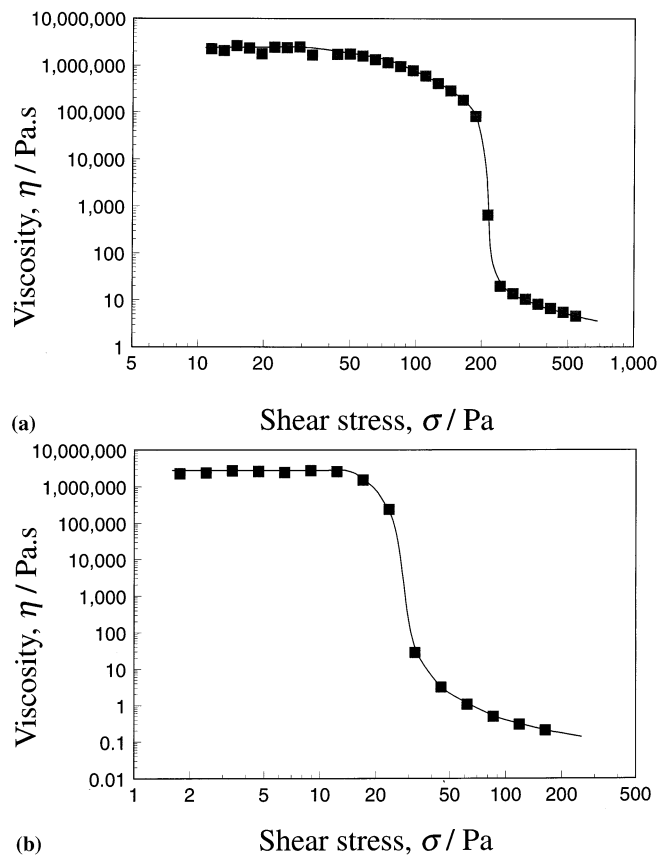

Fig. 9. Viscosity versus shear stress for various structured liquids measured in this laboratory using a controlled-stress rheometer, where great care has been taken to avoid wall effects, i.e. slip: (a) typical toothpaste data; and (b) 0.2% aqueous Carbopol 980.

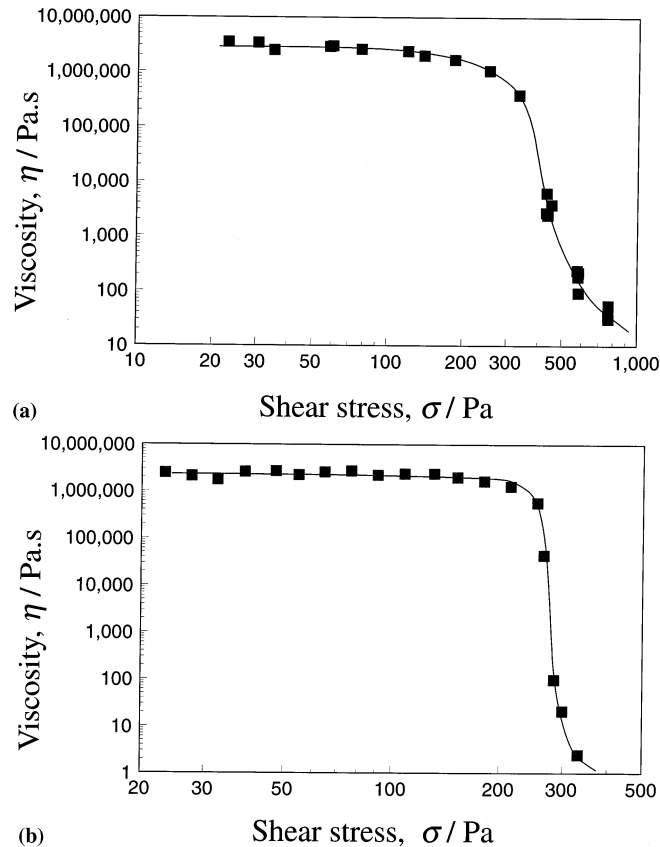

Fig. 10. Viscosity versus shear stress for various structured liquids measured using a controlled-stress rheometer, where great care has been taken to avoid wall effects, i.e. slip, for data kindly supplied to the author by C. Gallegos: (a) tomato puree; and (b) mayonnaise.

foods: starch-thickened strained apricots [60] molten chocolate [61], tomato purees [62,63], ice cream [64];

Waxy crude oils [65];

Volcanic lavas [66]

and other examples are given in different places throughout this text.

Barnes [39] went further than simply using a vane when he introduced a close-fitting wire-mesh cylinder inside the outer cylinder to prevent slip there also, which can often occur, but is usually ignored. Of course, use of a vane geometry at very high rotation rates is precluded due to secondary flow developing behind the vanes.

Theoretical analyses have been carried out by, among others, Yan and James [67] and Barnes and Carnali [68], who all essentially concluded that for yield-stress/very-shear-thinning liquids, the vane geometry acted as a circumscribing cylinder defined by the tips of the vane blades, with the material inside the virtual cylinder essentially acting as a solid body, and the material outside being sheared in the normal way. This ensured that slip is completely overcome at the rotating member.

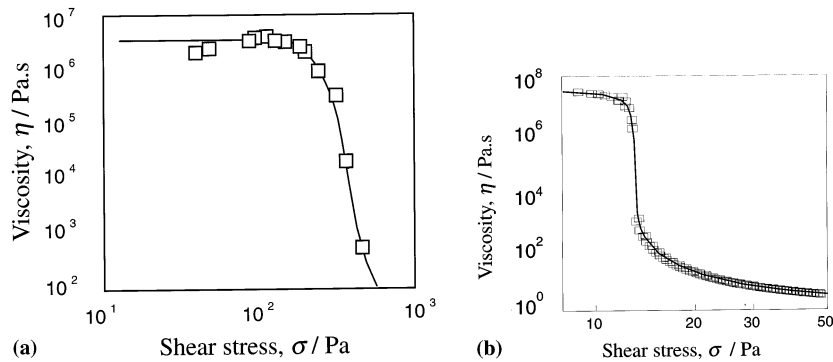

Fig. 11. Viscosity versus shear stress for various structured liquids measured using a controlled-stress rheometer, where great care has been taken to avoid wall effects, i.e. slip, for data previously quoted by the author in [39]: (a) a flocculated aqueous latex suspension; and (b) molten chocolate.

Alderman et al. [59] used a vane geometry to measure the yield stress of drilling muds and similar materials. They took the approach used earlier by Dzuy and Boger [69], but pioneered originally by Keentok [70], who measured the yield stress by increasing the stress until yielding took place. Often, the so-called yield stress was then a sharp maximum that the stress grew to at start-up and quickly fell away from as more shear took place and further breakdown occurred. The vane—or in its place the porous cylinder—seems to overcome the problem of wall slip for these heavily structured liquids. They give details on how to deal with problems arising from large end effects. Using a similar approach, Yongxing et al. [71] used the critical wall shear stress necessary to restart flow in crude oil pipelines. They then modelled the ‘thixotropic’ yield stress as a simple exponential function of rest time as it increased after flow cessation. Suck et al. [72] reported measurement of what they called the yield stress of an unnamed elastic liquid by observing its departure from linear behaviour in oscillatory shear. The shear stress and loss angle both departed from the expected linear response at a critical stress, and their measurement was independent of mode of testing, so either controlled-stress or controlled-strain oscillatory shear gave similar answers.

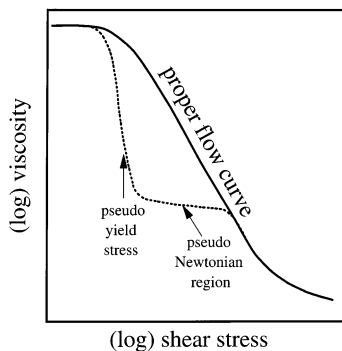

Fig. 12. A sketch of the effect of slip on a plot of viscosity versus shear stress for a structured liquid, showing the supposed lower Newtonian plateau and the false yield stress.

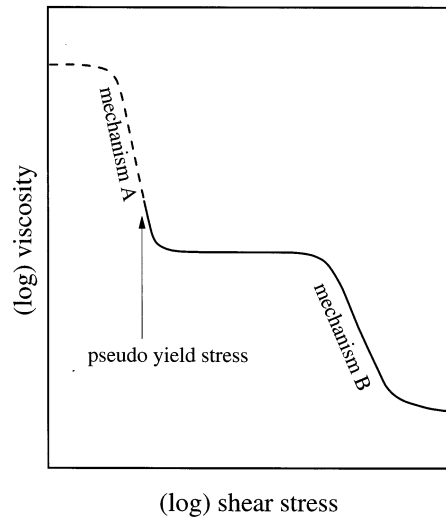

Fig. 13. A sketch of the viscosity versus shear stress plot for a structured liquid with two distinct and well-separated shear-thinning mechanisms.

4. Simple theories that seem to predict a yield stress

Simple descriptions of the viscosity of dispersions usually produce situations where the viscosity is predicted to become infinite. One of the simplest is that due to Quemada [73], which is a simplified form of the Krieger-Dougherty equation:

$$\frac{\eta}{\eta_c} = \left[1 - \frac{\phi}{\phi_m} \right]^{-2}, \quad (11)$$

where η and η_c are the viscosities of the suspension and the continuous phase, and ϕ and ϕ_m the phase volume and the maximum phase volume respectively.

These theories assume that, as the concentration of the dispersed phase is increased, the average distance between dispersed particles inexorably decreases, until the particles finally touch, resulting in a continuous network of connected particles with an infinite viscosity. The assumption that particles physically touch as $\phi \rightarrow \phi_m$ is of course merely an assumption, since the force required to make particles come into contact is enormous. (The extraordinary sensitivity of zero-shear-rate viscosity to small changes in volume concentration-at high concentrations-is demonstrated by the work of Buscall, [74], who showed that, whereas the value at a phase volume of 0.604 was ~ 200 times greater than the solvent viscosity, at 0.653 it was ~ 3000 , at 0.670 it was 10^5 , at 0.675 $\sim 10^6$, and above 0.688, the indication was of a viscosity ratio greater than $\sim 10^9$. However, even at the highest concentration used, 0.692, there is still an indication of the curve bending over to a finite viscosity, not turning up to a yield stress.)

Based on an extension of the Quemada treatment, Barnes [75] showed that we can expect a yield stress, followed by flow above a critical stress. This is because in the Quemada equation, ϕ_m is not a constant, but is a function of applied shear stress. Hence, at low stress, we have a three-dimensional, random arrangement of monodisperse, spherical particles in a flowing

suspension, giving a value of ϕ_m of ~ 0.64 . At high stress, the flow is strong enough to rearrange the particles into strings and layers (with the average separation between the particles less in the flow direction than across the flow direction), thus giving a lower viscosity. The value of ϕ_m is then higher, at around 0.7. This means that if we have a suspension with the phase volume ϕ between these two maximum phase volume values (i.e. $0.64 < \phi < 0.7$), at high stress it will flow, but at very low stresses the viscosity is infinite, and in between there is a critical or yield stress. This is given by

$$\sigma_y = [\phi_{m\infty}/B\phi_{m0}] [(\phi - \phi_{m0})/(\phi_{m\infty} - \phi)], \quad (12)$$

where the value of the maximum phase volume ϕ_m at any given stress σ , relative to its extreme values ϕ_{m0} and $\phi_{m\infty}$ at very low and very high stress values, respectively, is dictated by the relationship

$$[1/\phi_{m0} - 1/\phi_{m\infty}]/[1/\phi_m - 1/\phi_{m\infty}] = 1 + B\sigma. \quad (13)$$

As this is again based on the simplistic idea that particles touch, and that the lubricating layer disappears between adjacent particles, the theory is of course a gross oversimplification.

This simple theory can be extended to cover flocculated systems, assuming a fractal form to the floc. Then the yield stress is given by

$$\sigma_y = \frac{1}{A} \left(\frac{1}{a} \left[(R_0 - a) \left(\frac{\phi}{\phi_m} \right)^{D-\frac{1}{3}} - 1 \right] - 1 \right)^{\frac{1}{s}}, \quad (14)$$

where the radius of the floc R (of fractal dimension D) of individual particles of radius a is given by is given by

$$R = \frac{R_0}{1 + [A\sigma]^s} + a, \quad (15)$$

where R_0 is the floc radius at rest.

The question of whether such flocculated suspensions actually have a yield stress, even though the flocs are space filling, is perhaps answered by some interesting work presented by the colloid group at Bristol University Chemistry Department, which has many years of experience of looking at highly interacting colloidal systems. The one particular system that they examined and commented on was a dispersion of spherical particles of silica and poly (vinylidene fluoride) at high concentration: an extreme example of a solid particle gel [76]. The linear and non-linear viscoelastic properties were measured. What is particularly interesting about this paper is the authors' explanation of the resulting behaviour. They base their model on a grain boundary idea that is usually used for metals (see later), and propose an atomic-type jumping mechanism for adjacent particles to explain non-linearities. What they could have done, if their original measurements had been sensitive enough, was to measure and explain creep by the same mechanism! This picture could be transferred and used for any kind of suspension, and the ideas of grain-boundary models could be invoked. This could then be used to explain the creep behaviour of structured suspensions (see the work of James et al. [77]).

5. Areas where yield stresses are often quoted

5.1. Colloid science

The use of the simple Bingham model is much favoured by colloid chemists, even if there is plenty of evidence of departure from linearity at low shear rates. The appearance of an apparent yield stress (often measured as the extrapolated Bingham value) is used as a measure of maximum flocculation in a suspension, that is to say the overall attractive forces between the suspended particles are a maximum. This is often brought about by altering the pH of the system in order to minimise the intrinsic surface charge on the particle surface, and happens at the so-called isoelectric point, where the zeta potential is zero. This gives a minimum in the electrostatic repulsive force, so that the attractive forces present such as hydrophobic forces, van der Waals and bridging forces can predominate. Systems studied in this way include zirconia, [78–82], coal-water mixtures [83–85], alumina and zirconia mixtures [58], silicon carbide aqueous dispersions [86,87], alumina [56,88–91], nuclear waste simulants [91] and aqueous native ovalbumin solutions [92].

Snabe and Mills [93] have produced a theory for the flow of the kind of weakly aggregated flocculated systems described above, within the framework of a fractal aggregate. The equation, when applied to soft clusters of fractal dimensionality $D = 2$, is very similar to the Casson equation. They applied the theory successfully to the break-up of red cell aggregates.

Last, but certainly not least, we note again the work of James et al. [77] who performed a wide variety of tests in order to measure the yield stress of various concentrations of aqueous illite suspensions as a model for cohesive sediments such as estuarial muds. They found the results shown in Table 2, where large variations in the apparent yield stress are shown, depending on the method used.

Note that, in Table 2, σ_1 signifies where the stress/strain curve in the start up of a controlled strain experiment becomes non-linear, σ_2 refers to the maximum in the stress/strain curve under such conditions. Stress relaxation (1) is obtained by allowing relaxation from a steady-state flow

Table 2
Various yield stresses found for an aqueous illite suspension using a variety of rheometrical methods [77]

Methods used	σ_y for 2.5% illite (Pa)	σ_y for 5% illite (Pa)
Direct:		
Controlled strain, σ_1	0.89	3.5
Controlled strain, σ_2	0.7	3.00
Stress relaxation (1)	0.26	2.79
Stress relaxation (2)	0.32	2.90
Applied stress (vane)	1.93	7.6
Applied stress (bob)	1.92	6.7
Indirect:		
Casson intercept	0.26	0.66
Log/log intercept	0.35	1.50
Bingham intercept	2.20	8.50

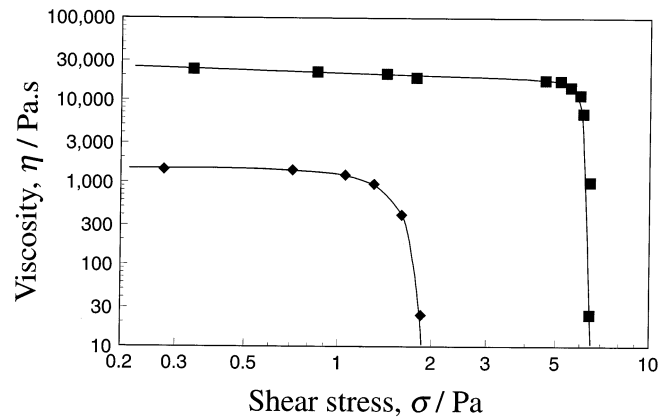

Fig. 14. Viscosity versus shear stress curves for aqueous illite suspensions, at 5% (squares) and 2.5% (diamonds) respectively, replotted from Williams and Williams [94].

at the lowest shear rates employed by suddenly stopping the rotating member, while the stress relaxation (2) figure was when the rotating bob was gradually slowed to become stationary over 5–7 s. The indirect methods were extrapolations to very-low/zero stress on various plots. The methods used were very different, some being steady state, and others transient, among the latter was testing from rest with a fixed rotation rate for a vane geometry, as used by many other workers. They concluded that although they had produced a wide variety of apparent yield stresses derived from different methods of measurement, ‘some (very slow) viscous flow occurs under all conditions employed... if sufficient time is allowed’. Interestingly the yield stresses found by Bingham extrapolation are very similar to those found as the stress maximum via the vane, showing that the coincidence of results for very difference of techniques is completely accidental, the former being extrapolated from above from high shear rate steady flow and the latter from transient deformation from rest!

The same group, see Williams and Williams [94], measured the yield stress of real cohesive mud sediments and model illite suspensions (Fig. 14), where the viscosity *below* the apparent yield stress is shown. They also found that the elastic properties in this region—the compliance from the initial deformation—showed linear behaviour. In a corresponding publication [95], they also showed the effect of wall slip on the measurement of apparent yield stress of sediments, smooth-walled rheometer measurements gave values of 23, 27 and 32 Pa, but a vane geometry gave 62, 105 and 111 Pa, respectively, for volume concentrations of the muds of 8.8, 15.6 and 16.8%.

5.2. Food science

Steffe [96] defined apparent yield stress in the usual way, as the minimum shear stress required to initiate flow, and went on to list at least seven ways he had measured it for liquid-like foods, including extrapolation (two variants), stress decay after flow (two variants), stress to initiate flow (six variants), non-linear dynamic testing, vertical plate coating, squeezing flow and cone penetrometry. He noted however that ‘an absolute yield stress is an elusive property: it is not

unusual for a yield stress obtained by one technique to be very different from one found by using a different method'. He then listed the values of apparent yield stresses measured for different sorts of food, ranging from ketchup, ~ 15 Pa, spaghetti sauce at ~ 25 Pa; mustard and apple sauce at ~ 60 Pa; mayonnaise at ~ 90 Pa; and tomato paste at ~ 125 Pa. Within the limited time-scale of eating, it is obvious what the concept of yield stress means to the non-expert, in terms of, for instance, the finite spread of a liquid-like food when poured out, which seems to come to a constant thickness. Also in food processing, given the limited time-scales of many processing operations, the thickness of layers of liquid-like foodstuffs left on vertical walls after drainage has taken place, is given by $\sigma_y = \rho gh$, where ρ is the fluid density, g is the acceleration due to gravity, and h is the layer thickness. Having, for instance, emptied a vat of such a liquid product, we could then calculate, at least in the short-to-medium term when the liquid does not *appear* to flow, the thickness of the layer left on the wall of the vessel, which has to be removed in any ensuing cleaning operations.

5.3. Chemical and biochemical engineering

Patel [97] summarised the importance of an apparent yield stress in mixing very non-Newtonian liquids in a vessel, where the dimensions of the 'cavern' of visibly moving liquid are determined by a combination of geometrical, rheological and power parameters. She noted that a wide range of bio-mass broths and model fluids (mostly Carbopol solutions) could be approximated to by either the Bingham or the Casson equation. However, the complete flow curve when measured on a stress-controlled rheometer showed the 'normal' behaviour (Fig. 15). She confirms the usefulness of Elson et al.'s [98] earlier prediction of the cavern size for model fluids (Carbopol and xanthan gums) given by

$$\left[\frac{D_c}{D} \right]^3 = \frac{1.36P_0}{\pi^2} \left[\frac{\rho N^2 D^2}{\sigma_0} \right], \quad (16)$$

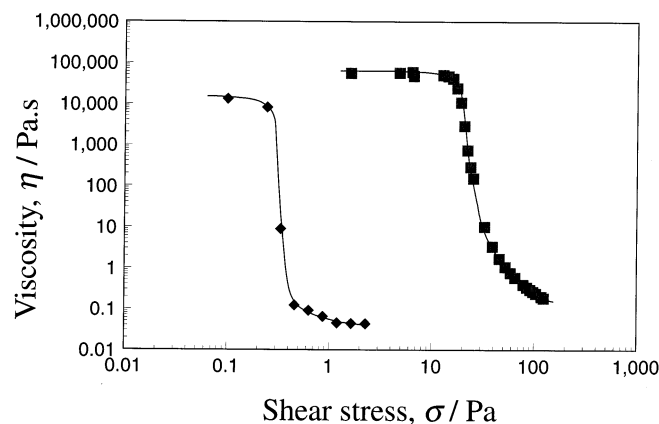

Fig. 15. Viscosity versus shear stress curves for a penicillin broth (diamonds) and a 0.4% Carbopol suspension (squares) replotted from Patel [97].

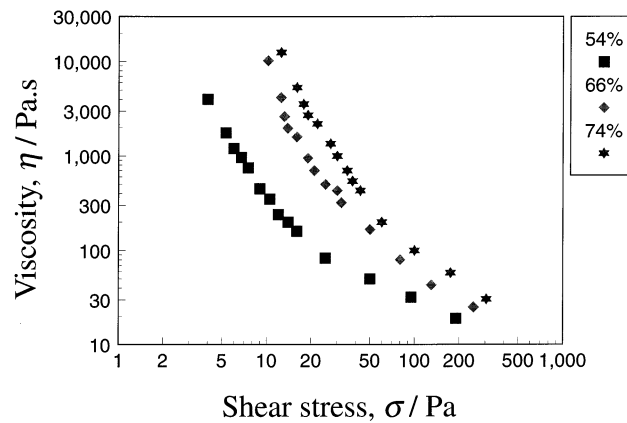

Fig. 16. Picart et al.'s [100] data on blood replotted here as viscosity versus shear stress, for various values of hematocrit.

where D_c is the diameter of the cavern, D is the diameter of the impeller, P_0 is the impeller power number, N is the impeller speed. However, the yield stress used was very specific, i.e. that obtained using the Casson model fitted to data for shear rates $< 0.2 \text{ s}^{-1}$ but $> 0.052 \text{ s}^{-1}$, following Elson et al.'s original formulation, using data from a Contraves Rheomat 30. However, this formulation failed to predict the correct values for real fermentation broths, where better correlation resulted from taking the maximum stress from a vane geometry when driven at slow speed from rest.

A simple analogy to cavern formation is where no flow appears to take place after a critical distance away from the rotating inner cylinder in the flow of a 'yield-stress' fluid in a wide-gap, concentric-cylinder viscometer (e.g. Zhang and Nguyen [99]).

5.4. Blood flow

Picart et al. [100] recently examined the flow properties of human blood using a concentric-cylinder viscometer with rough walls to eliminate the considerable slip effects that they found with smooth walls. They give a very good review of the subject of yield stress in blood and refer to the work of Cokelet et al. [101] who recognised the difficulty of assigning an absolute value to the yield stress of blood. They themselves took the value of the shear stress at a shear rate of 10^{-3} s^{-1} as a measure of yield stress. However, in each case cited by them, the stress is obviously still slightly decreasing at shear rates around 10^{-3} s^{-1} , for the three levels of cell concentration quoted, viz, 54, 66 and 74%, respectively. In Fig. 16, their data has been replotted as viscosity as a function shear stress (on a logarithmic basis) and we see that the most we can say is that as the stress decreases, the viscosity/stress relationship approaches a steep power-law relationship, with no indication of an asymptotic increase in stress as one approaches a critical stress. However, in describing this behaviour in terms of stress versus shear rate, Picart et al. [100] make the unusual comment that 'the curves... had a gentle slope at shear rates below 0.5 s^{-1} , which was representative of the typical behaviour of yield stress fluids!' This work, like so many others, illustrates the misconception that can be introduced if the stress/shear-rate alone

is used where, for this kind of material, the stress changes very slowly with shear rate, and not the more enlightening viscosity/stress curve, which, if used, removes any notion of a yield stress. What their work also shows is that very low stresses indeed would be needed to access the lower Newtonian plateau, certainly less than 1 Pa. For the same measurements made using a smooth geometry, the stresses at very low shear rates were much lower, and it appeared that blood showed Newtonian behaviour at low shear rates. This has been seen by others, and led to the conclusion that blood did not have a yield stress. So far, what we can say is that blood does not have a yield stress, but the true, very-high Newtonian plateau viscosity at low shear stress has not been measured.

Over the years, many other workers have reported on the yield stress in blood. However almost all have used smooth-walled viscometers, taking no precautions to avoid slip effects. As we have seen above, Picart et al. [100] showed unequivocally that such effects have a very large effect on any measurement of blood at low shear rates, hence such reports must be treated with caution as to their *absolute* quantitative reliability, although *trends* are probably unaffected. Increases in such supposed yield stresses in human blood have been assigned to a number of pathological conditions, the following being some examples, sickle cells [102], myocardial infarction [103], raised hematocrit and plasma viscosity [104], gender (male > female) and age [105], stroke [106] and diabetes [107].

Blood has recently been modelled using both the Bingham and the Herschel-Bulkley model, [108] for the prediction of the flow of pulsatile flow through arterial stenoses. From the Picart et al.'s [100] data, the Herschel-Bulkley model could reasonably well describe the data.

6. Flow of solids

6.1. General

If a yield-stress material behaves as a solid below the yield stress, we may quite properly ask the question, 'How do solids behave below their yield stress, especially when examined over very long time periods of stress?'. A number of comprehensive texts have appeared over recent years giving us an overview of this behaviour, probably the most extensive being that of Frost and Ashby [109]. Their deformation maps cover most solid materials, e.g. metals, ceramics, ice, etc. They show that, if brought within the range of measurability by increasing the test temperature, almost all materials will show creep, however low the applied stress. By creep we understand the steady-state, continuous deformation of a material when a stress is applied, and this is usually after an initial linear elastic deformation and may take some time to arrive at steady state.

In solids testing, great care has to be taken to avoid the initiation and propagation of cracks, which would greatly interfere with the results, because localised cracks can open slowly and this can be mistaken for overall creep. The problem is usually overcome by applying a very large hydrostatic confining pressure to the sample to seal up any such cracks. When this is done, and the specimen is taken to a high-enough temperature, meaningful measurements can be made. 'High-enough' here usually means above 0.5 of the melting point in degrees absolute, K, of the material. The material is still 'solid' at these temperatures, but creep rates are then usually brought within the measurable range, i.e. $> 10^{-9} \text{ s}^{-1}$. The lowest creep rates referred to on the maps by Frost and Ashby as relevant are 10^{-10} s^{-1} .

When results from these experiments are collated, a simple picture for most stressed solid materials emerges:

1. After a long-enough time, a steady creep rate *is* achieved;
2. this creep rate, at low-enough applied stress, usually becomes a linear function of applied stress—in the language of the rheologist, this linearity signifies *Newtonian* behaviour—and is governed by atomic diffusion and,
3. at higher stresses, the creep rate increases faster than the stress, and usually shows a power-law-like behaviour.

Above this power-law region, other phenomena lead to different kinds of creep behaviour, but among them is a situation where the creep rate (often quite large by now) tends again towards a linear function of applied stress—the so-called drag-controlled plasticity—, i.e. in rheological parlance an upper Newtonian behaviour. If we express this response as would normally be done for a structured liquid, the identical behaviour would be as shown in Fig. 17.

The creep results of most solid materials, in the customarily observed linear followed by power-law regions, can be fairly well described by the empirical Ellis equation (omitting the usual high-shear-stress asymptotic viscosity),

$$\frac{\eta}{\eta_0} = \frac{1}{1 + \left(\frac{\sigma}{\sigma_0}\right)^m}, \quad (17)$$

where η is the steady-state creep viscosity measured at a stress of σ , η_0 is the zeroshear-rate viscosity, σ_0 is the critical stress which determining the *region* of shear stress where the material shows significant departure from linearity, and m is another material parameter—this time dimensionless—which determines the *rate* of departure from linearity. The results can often be expressed equally well by using the Cross model, which is essentially the same as the Ellis model, but where the stress is replaced by the shear rate.

Some further examples of this kind of behaviour are shown in Fig. 18, and the approximate parameters for other solid materials are collected together in Table 3. It is useful also to collect together some very approximate values of Newtonian steady-state ‘creep’ viscosity η_0 for a range of ‘solid’ materials (mostly at room temperature) culled from the general scientific literature,

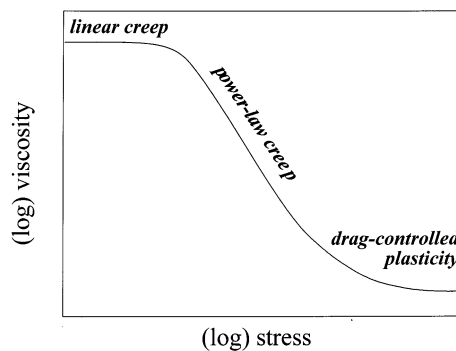

Fig. 17. Typical creep data for solids replotted as viscosity versus stress, showing the various well-known creep regimes.

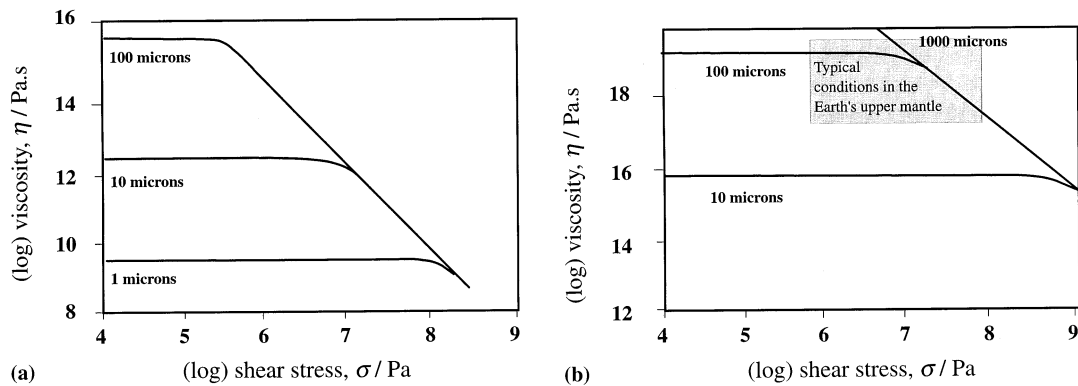

Fig. 18. Viscosity versus stress data at 1000°C, derived from [109], for various grain sizes of: (a) magnesium oxide; and (b) olivine (a rock).

showing typical examples for each viscosity decade from 10^{21} down to 10^6 Pa s, arranged in \log_{10} increments:

21-the earth's mantle	17-marble	13-ice	9-bitumen
20-glass	16-cement	12-solid soap	8-ice cream
19-steel	15-polyethylene	11-asphaltic concrete	7-resins
18-mortar	14-tin	10-cheddar cheese	6-gelatine gel

In these systems, we either have materials in a super-cooled, glassy state, and hence their flow is the same as that of other liquids but is very slow, or else for 'solid' materials flow is usually via the integrated effect of atomic jumping movements along grain boundaries.

Table 3

Approximate values of the Ellis model parameters that describe the creep of some 'solid' materials

Material	Grain size	Temp.	η_0	σ_0	m
Spinel, a mineral	10	1000	4.64×10^{16}	7.4×10^7	1.2
α -Alumina	10	1200	1.25×10^{16}	4.8×10^7	1.1
Zinc carbide	10	1600	2.00×10^{16}	1.5×10^6	2.9
Lithium fluoride	50	500	2.45×10^{14}	2.7×10^6	4.6
Sodium chloride	50	400	3.02×10^{14}	1.7×10^6	4.3
304 Stainless steel	100	600	6.20×10^{15}	2.5×10^7	3.6
Titanium	100	900	1.00×10^{15}	1.0×10^6	2.9
Ice	100	-8	1.02×10^{13}	3.2×10^5	2.1

η_0 , the zero shear rate viscosity (Pa s); σ_0 , the critical stress (Pa); and m , the non-linearity index [-].

The grain size (μm) and test temperature data ($^\circ\text{C}$) are also included. The data has been read off graphs in Frost and Ashby's book [109] and has been fitted to the Ellis model. The grain size is included because it controls the values of η_0 and σ_0 (but not the value of m), Fig. 18.

Superficially, nothing seems more solid-like than the rocks of the earth, but even they creep, as shown in some examples above, (as the prophetess Deborah said in the Bible, ‘even the mountains flow before the Lord’, see M. Reiner’s translation of Judges 5:5 [110]), and the very long time scales appropriate to geological studies mean that even very high viscosities and the resultant very low shear rates are very significant. Long-term creep experiments on natural quartzites led to viscosities in the region of $3\text{--}4 \times 10^{15}$ Pa s being quoted recently [111]: cooled lava viscosity is said to be $\sim 10^{12}$ Pa s [112] and a viscosity of $\sim 10^{-8}$ Pa s was thought about right for modelling tectonic plate movement in the Iceland area [113]. Pollitz and Sacks [114] quote viscosities of $\sim 3 \times 10^{19}$ and 3×10^{18} Pa s for lower crust and upper mantle respectively. Magmatic flow of crystallising gabbros below the free surface of basaltic magma chambers have viscosities in the region $10^{14}\text{--}10^{16}$ Pa s and experience shear rates near 10^{-9} s $^{-1}$. Other crustal viscosity levels are quoted in the region of 10^{24} Pa s. [115]. These are the every-day figures used by geologists, but which are usually outside the thinking of every-day rheologists!

6.2. *The flow of Plasticine™, a typical soft solid*

Plasticine™, the well-known modelling material (obtainable from Peter Pan Playthings, UK), is a concentrated dispersion of clay particles in mineral oil, which as its name implies, is a very plastic soft-solid material, obviously exhibiting an apparent yield stress. It offers some very special properties: it is cheap, readily available, reasonably stable and non-drying in the short term. It has the added advantage that it can be layered in different colours, reassembled before experimentation, and cut after working to show the extent of deformation within in each of the coloured layers. Where it is in contact with solid surfaces it can be lubricated if necessary. It has thus been extensively used as a yield-stress soft solid in squeeze-film deformation (sometimes called upsetting) [116], indentation [117], scratch hardness and friction [118], as well as studying interface constraints [119], and general flows such as extrusion through orifices and through tubes [120], as well as a model in powder compaction studies [121].

In terms of geological studies, Plasticine™ has proved itself invaluable as a model for testing theories of strata deformation under laboratory conditions for fold thrust structures [122], and strata buckling [123–125]. Plasticine™ have also been used to simulate soft soils [126].

However, the most extensive use of Plasticine™ has been in the modelling of metal working operations such as forging [127], rolling [128], milling [129], extrusion [130–132], cutting [133] as well as many other metal component forming processes [134–137]. These are but a few of the references of recent use of Plasticine™ in metal working—there are many more.

Given that Plasticine™ is such a useful model yield-stress material in a wide range of operations, and is well characterised at high deformation rates using the Herschel-Bulkley equation, what happens at low stresses below the extrapolated yield value, where the material is not supposed to flow according to the restrictions of such theories? In this laboratory, we have examined Plasticine™ under creep conditions under very long-time testing (i.e. days) using a sensitive, controlled-stress rheometer (mounting the sample as a rod and following the twist with time). Typical non-Newtonian, steady-state liquid behaviour is seen (Fig. 19), where the results are compared to those obtained at the higher deformation rates experienced in extrusion through a short orifice.

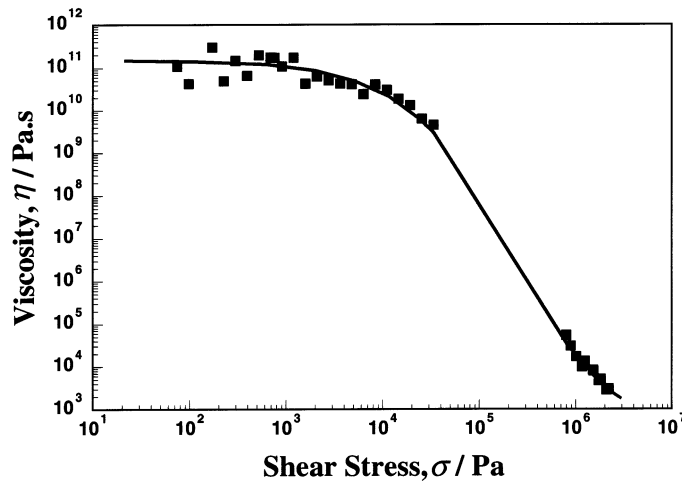

Fig. 19. Viscosity versus shear stress for Plasticine™. Data at low stress obtained using a controlled-stress rheometer, and data at high stress ($\sim 10^6$ Pa) obtained from high-pressure orifice flow.

This shows that for one interesting material at least, there is no real inconsistency between, on the one hand, describing a soft solid as having a yield stress in the ‘engineering’ situations where it is visibly flowing, and, on the other hand, saying that it does not have a real yield stress when tested under precise rheometrical conditions, where very small shear rates are capable of being measured at very small stresses at very long times.

7. The proper use of yield stress in liquids

7.1. General comments

If we accept a pragmatic approach and feel that we need to measure yield stress, then what is the best method? The answer will be controlled by the end use (see Astarita’s comments in [35]). Once obvious artefacts such as wall slip have been removed or accounted for, and we are able to measure down to shear rates as low as 10^{-3} s^{-1} , we are usually left with a curve that, on a logarithmic basis of shear rate against shear stress, shows a shallow slope, (sometimes as low as 10% in stress per decade of shear rate). For this reason, it seems sensible to follow Piau’s group (see Picart et al. [100], in simply defining a pragmatic value of yield stress as the stress at a shear rate of $\sim 10^{-3} \text{ s}^{-1}$.

In the author’s experience, the best way to describe the curve from 10^{-3} s^{-1} and above is by using the Sisko model. However, if it is easier, then one of the models with a yield stress can be used. For utility sake, a Bingham model has more worked out mathematical solutions, compared to Casson or Herschel-Bulkley models.

Schurz [138] presented what he thought was a true yield value in a solution of very high molecular weight cellulose trinitrate in butylacetate. Five different types of viscometers were used to obtain the full flow curve. He saw what appeared to be the normal type of flow curve for a

polymer, with a low and high shear-rate Newtonian plateau, but where the viscosity began to rise again off the plateau at lower stresses. Unfortunately, this is precisely the kind of expected effect described by Barnes [39] in his review of wall slip. We cannot take this data seriously, since no precautions are mentioned to eliminate slip, and Barnes and Carnali's [68] work on the use of a vane geometry on a similar system shows the slip problems that can arise, but once eliminated 'show the absence of a true yield stress'. However, in his discussion of the situation, Schurz [138] comments that 'we think the discussion of a yield stress is a 'Streit um des Kaiser's Bart', i.e. squabbling over the Kaiser's beard, meaning—is the argument worth having? He suggests keeping everybody happy by talking about an apparent yield stress, characterised by the experimental conditions used!

7.2. Modelling a 'yield-stress' liquid with simple mathematical equations

Whether or not yield stresses exist as a physical reality, and have a unique value invariant to the method or range of measurement used, there can nevertheless be no arguing with the fact that much useful progress has been made in applied rheology by using simple, yield-stress-containing equations that fit steady-state, shear-stress/shear-rate data quite well over a *limited* range of shear rates. In like manner, if these equations are used to predict flow in any other situation, where *the same range of shear rates applies*, this is completely acceptable and uncontroversial, and can indeed be very effective.

The most popular equations that have been used to describe liquids with yield stresses are the Bingham [13], Casson [21] and Herschel-Bulkley [139] (sometimes called the generalised Bingham) models, i.e.

$$\sigma = \sigma_y + \eta_p \dot{\gamma} \quad \text{Bingham,} \quad (18)$$

$$\sqrt{\sigma} = \sqrt{\sigma_y} + \sqrt{\eta_p \dot{\gamma}} \quad \text{Casson,} \quad (19a)$$

or squaring Eq. (19a) to compare with Eq. (18),

$$\sigma = \sigma_y + \eta_p \dot{\gamma} + 2\sqrt{\sigma_y \eta_p \dot{\gamma}}, \quad (19b)$$

$$\sigma = \sigma_y + k\dot{\gamma}^n \quad \text{Herschel – Bulkley.} \quad (20)$$

In the last 12 years, these models have been used extensively in papers published in the scientific and engineering literature. For instance, using the Institute of Scientific Information citation databases, the following frequency—and hence popularity—of each model over the last dozen years may be noted: Bingham (plastic, fluid, liquid, etc.), 223 citations; Casson (equation, fluid, model etc.), 76 citations and Herschel-Bulkley (fluid, model etc.), 97 citations.

Barnes et al. [1] showed that the Bingham model is the most non-Newtonian example of the Sisko model, which is itself a simplification of the Cross (or Carreau model) under the appropriate conditions. Most workers now using the Bingham model explain that they are extrapolating from the straight-line portion of the shear-rate/shear-stress curve to obtain the yield stress, σ_y , and plastic viscosity, η_p , and are not attempting to describe the whole curve (see for instance Rossi et al. [140]).

A very good recent example of the applicability of the Casson equation is provided by Laun [141], where the lowest shear stresses used were of the order of 1 Pa. However, no creep data

were provided and where the Casson plot was applied to the lowest shear rate data, it failed below $\sim 0.01 \text{ s}^{-1}$.

van Dieren [142] used the Herschel-Bulkley model to describe the flow of a high-internal-phase-volume, oil-in-water emulsion, with 80% paraffin using Dobanol as an emulsifier. He found that the exponent n on the power-law part of the equation was near to 0.5, so that when plotting stress versus square-root of shear rate, he obtained straight lines in the shear rate range $\sim 1\text{--}300 \text{ s}^{-1}$ [143]. Benezech and Maingonnat [144] modelled yoghurt using the Herschel-Bulkley equation over a shear rate range $\sim 50\text{--}500 \text{ s}^{-1}$, and the yield stress was measured using a controlled-stress rheometer (no method specified), which was the shear rate range in a heat exchanger of interest.

Battacharya and Javadpour [145] calculated the helical flow of Herschel-Bulkley fluids to model an on-line coaxial cylinder rheometer, and reduced the expression to a Bingham model, i.e. $n = 1$. They successfully described flow for a Carbopol–glycerol–water mixture for shear rates in the range $\sim 50\text{--}600 \text{ s}^{-1}$.

When commenting on the use of the three principal yield-stress equations, Nguyen and Boger [38] said that for the Bingham model ‘the use of this model can lead to unnecessary over-prediction... Extrapolation of the Casson model... is straightforward... The application of the Herschel-Bulkley model... is more tedious and less certain... Even with the most suitable model and appropriate technique, the yield value obtained cannot be regarded as an absolute material property because its inaccuracy depends on the model assumed and the range and reliability of the experimental data’. They then go on to describe how, in a few instances, the same liquid was equally well described by a number of models, each having a different yield value.

7.3. Some comments on the forms of the yield-stress equations

If we examine the typical form of a flow curve for a yield stress liquid, it is obvious how the usefulness of the Bingham, Casson and Herschel-Bulkley equations has come about. A Newtonian liquid has one flow parameter—the viscosity. The simplest non-Newtonian models have two parameters, e.g. the power-law and Bingham models. Other complexity needs more parameters, e.g. the three-parameter models such as the Herschel-Bulkley and the Sisko models. In Fig. 20, we have plotted examples of all these equations as representing some hypothetical but typical data for a Cross model using four parameters that well describes the complete flow curve of many liquids. The two- and three-parameter models are fitted over the region of higher shear rates. Both the Bingham and the Sisko models do well at very high shear rates, in predicting asymptotic movement to a constant viscosity. However, both the power-law and the Herschel-Bulkley models predict an unrealistic, ever-decreasing viscosity at high shear rate. At an intermediate shear rate, both the Bingham and the Herschel-Bulkley models do well in predicting a flattening of the stress as a function of shear rate. The limits in terms of the logarithmic slopes of the shear-stress/shear-rate curves of all these laws are as follows (Table 4):

Of these, only the Sisko model predicts a continued decrease to very low shear rates. Of course, all the two- and three-parameters models fail to account for a limiting very-low-shear-rate *Newtonian* viscosity, usually found in creep tests.

When deciding on the most appropriate equation to use, it is a good idea to follow the principal of ‘Ochham’s razor’. In the middle ages William of Ochham (1285–1349), an English

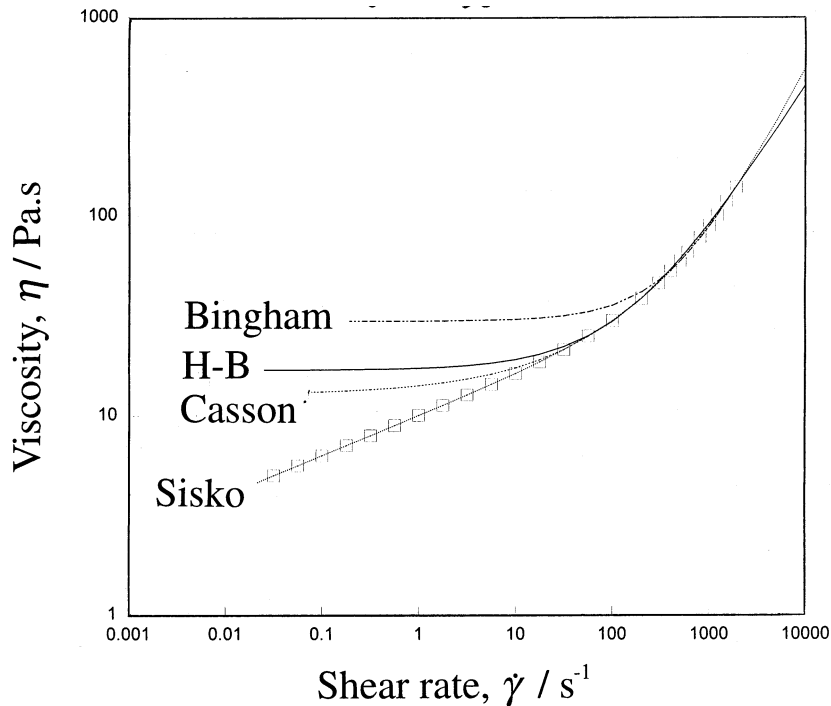

Fig. 20. Various yield-stress models—Bingham, Herschel-Bulkley and Casson—compared with hypothetical data derived for a typical structured liquid using the Cross model, with $\eta_0 = 10^6$ Pa s, $\eta_\infty = \text{mPa s}$, $m = 0.9$ and $k = 10^5$ s. Model parameters chosen to give a good visual fit to the data in the $200\text{--}2000 \text{ s}^{-1}$ shear rate range. The Sisko model is also shown, with parameters derived by simplifying the Cross model.

monk, propounded the philosophical principle that *‘frustra fit per plura quod potest fieri per pauciora’*, which roughly translated from the Latin says that it is inefficient to do with more what can be done with less. That is to say, in our situation, if the Bingham model—the most economic on parameters—is good enough for the particular curve-fitting application, then use it, and if that is not good enough, then use the Casson equation, and so on to the Herschel-Bulkley model, given the difficulty of extracting the parameters for the latter (see Briscoe et al.’s helpful discussion of the sensitivity of the parameters of the Herschel-Bulkley model for describing soft solids, [146]).

Table 4
Limits of the logarithmic slopes of the various flow models

Model	Low shear rate	High shear rate
Bingham	0	1
Casson	0	1
Herschel-Bulkley	0	n
Sisko (i.e. Cross)	$1 - m$	1

7.4. Problems with yield stress and mathematics

The behaviour of a Bingham or similar material at the yield stress is essentially catastrophic, and is in no way ‘smooth and differentiable’ in a mathematical sense. Below the yield stress, the viscosity is always immediately infinite, and above, it is an asymptotically decreasing function of shear stress, usually approaching a constant value of viscosity as the stress becomes infinite. If this viscosity is zero, we have a St. Venant body, with a finite, constant stress, independent of deformation rate [14]. These problems can lead to inconsistencies in the numerical modelling of flow in complex geometries [147], and difficulties in properly defining the boundaries between non-deforming ‘solid’ zones and flowing ‘liquid’ zones.

Dealing with a yield stress needs special attention when working in three dimensions. Hohenemser and Prager [148] and Oldroyd [31] introduced a tensorial formulation for the Bingham plastic, using the von Mises criteria:

$$\sigma = 2 \left\{ \eta_p + \sigma_y (4\Pi_d)^{-\frac{1}{2}} \right\} d \text{ for } tr \sigma^2 \geq 2\sigma_y^2, \quad (21)$$

where Π represents the second invariant of the extra stress tensor, hence $\Pi_\sigma = tr \sigma^2/2$ and $\Pi_d = tr d^2/2$, where d is the deformation tensor and σ is the stress tensor. Other yield-stress criteria have been suggested, such as the Tresca criterion [149]. Good use has been made of this approach by Wilson [150] on squeezing flow; Szabo and Hassager on flow in eccentric annular geometries [151] and Beverly and Tanner [152] for axial flow through concentric cylinders.

Hammad and Vradis [153] avoided the infinite-viscosity singularity problems encountered using a simple Bingham model by adopting a ‘bi-viscosity’ Bingham model for flow in pipes and contractions (the simple Bingham model can be recovered as a limiting case). Nieckele et al. [154] use the same approach to good effect in modelling the flow of a viscoplastic materials through a staggered array of tubes (as found for instance in a heat exchanger) using a finite-volume method with a non-orthogonal mesh.

Abdali et al. [155] presented some very illuminating results from a simulation of entry and exit flows into a circular tube of a modified Bingham fluid which eliminated stress singularities, using Papanastasiou’s clever extra exponential term [156]. They also give a useful summary of similar previous work on simulation using Bingham fluids. The form of the flow into a constriction they predicted is shown schematically in Fig. 21 for different values of σ_y^* , where the latter is given by $\sigma_y D / \eta_p V$, σ_y being the yield stress, D the tube diameter, η_p the plastic viscosity, and V is the average velocity of a corresponding Newtonian liquid with viscosity η_p flowing in the tube under the same pressure gradient. As the flow becomes more and more dominated by the yield stress, the velocity profile becomes more plug-like, and p the ratio of entry pressure relative to the wall shear stress increases substantially as approximately: $p = 0.57 (1 + \sigma_y^*)$. The ratio of the total entry and exit pressures summed to the wall shear stress (i.e. the so-called Bagley correction) is given by: $P_B = 0.587 (1.4 + \sigma_y^*)$. Thus, Bingham fluids show a considerable increase in end corrections vis à vis Newtonian liquids. This arises presumably because the material deformation is restricted in the tube to just near the wall, but in the entrance, almost all the material has to deform to enter the tube (see also [157] for similar work on flow through an orifice).

Finally, we note the work of Yang [158] who produced an exact solution for the squeeze flow problem for the Herschel-Bulkley and the bi-viscous models under perfect slip conditions. He



Fig. 21. A sketch of the predicted flow of a Bingham fluid into an abrupt 4:1 orifice for various levels of yield stress, as assessed by σ_y^* , from [155]. Dark areas indicate domains where the stress is below the yield stress, i.e. no flow, while white areas indicate domains above the yield stress, i.e. flow.

found that no yield surface existed in the material squeezed between the plates, and that, for the Herschel-Bulkley model, the mean pressure applied to the top plate must be greater than $2\sigma_0/\sqrt{3}$. Yang suggested that this answer provided a simple means of measuring the yield stress. The bi-viscous model gave a similar result, but from an extrapolated intercept pressure. In a practical situation however, lubrication to give perfect slip is still not a trivial matter.

8. Conclusions

The arguments raised here as to the non-existence of a true yield stress are certainly not new, for instance we can quote again Reiner's statement in 1928 at the first ever Rheology Meeting referring to Bingham materials, 'there was no yield point' [14]. We can also note the comment from the 70-year-old, seldom-quoted but excellent work of Hatschek on colloidal solutions [159], who, very pointedly, said of Bingham's straight-line-with-intercept idea, '...[this] has hardly been realised experimentally even in such paste-like systems as Bingham investigates, nor certainly in any typical sol of which the author is aware', backing up his argument by the lowest shear-rate data to date, down to 10^{-2} s^{-1} . Lastly we quote (and heartily concur with) the belief of Coleman, Markovitz and Noll [160] that 'The concept of a plastic material has been greatly overworked. Almost without exception the yield values reported have been obtained by extrapolation of limited data. When careful measurements are made below the 'yield stress', it is found that flow actually does take place'.

Of course, anyone testing a very non-Newtonian fluid (e.g. toothpaste, Carbopol, tomato puree etc.) in a viscometer with a limited range of shear rates—say the typical $\sim 1\text{--}1000 \text{ s}^{-1}$

of a typical laboratory viscometer—and plotting the results linearly, is almost *bound* to come to the inescapable conclusion that the liquid has a yield stress. We have shown typical plots of restricted and complete shear-rate/shear-stress ranges. The obvious conclusion would be that each had a yield stress, but careful and complete measurement of the flow curve using the appropriate equipment shows that no real yield stress exists, but that the flow curve is quite normal, if extreme. However, it is perfectly acceptable to use an equation to try to describe data over a limited shear rate range using an expression that contains a yield stress term, but this describes limited data and not the material being tested, which itself does not possess a yield stress! In this respect we do not need to go as far as the seemingly pessimistic view of Albert Einstein who stated that ‘as far as the laws of mathematics refer to reality they are not certain and, as far as they are certain, they do not conform to reality!’ [161]

It should come as less of a shock to rheologists today than it came to metallurgists some time ago, to learn that materials of interest to them creep when stressed below the apparent yield stress (even in 1960 Bondi noted that ‘Like other plastic materials, lubricating greases exhibit creep at (shear) stresses below the yield stress’, [162]). For most working metallurgists, such creep can be ignored, being of interest only in the most extreme circumstances, such as a combination of high stress, high temperature and long times, e.g. ageing pressure vessels in atomic power stations. In the same way, most working rheologists can forget about the esoteric arguments that rage over the nature of the yield stress, and can happily go on using their yield-stress figures and equations, with the proviso of course that they only use the values to describe situations within the same range of shear rate over which the data was derived. However, those interested in, for instance, long-term storage stability of products with suspended particles over a range of storage temperatures cannot afford to ignore the controversy, since the flow properties in such circumstances are far from simple, and creep effects will dominate.

If Rheology had been able to keep its original breadth in covering both solids, soft solids and liquids (following for instance Andrade [19] and Scott Blair [17], see also Reiner [14] in his Postscript), then many of the kinds of problems outlined here would not have occurred, since by a process of normal cross-fertilisation, those working in material science on the creep of solids, geologists routinely looking at the flow of rocks, and fluid rheologists would all have agreed to accept and profit from the knowledge that flow always takes place below the supposed yield stress and that in effect, $\pi\alpha\nu\tau\alpha\ \rho\epsilon\iota$ —everything flows!

In another context Reiner [15] has said that ‘the road of rheology... is strewn with mistakes... but we have a lot to learn from mistakes, [and] need not be ashamed of them’—let us hope this is the case with the yield stress.

Acknowledgements

I am indebted to Geraint Roberts for help in preparing the graphs; to Cris Gallegos for supplying some viscometric data and to Derek Bell for checking the controlled-stress rheometer specifications data.

References

- [1] H.A. Barnes, K. Walters, *Rheol. Acta* 24 (4) (1985) 323.
- [2] C.W. Macosko, *Rheology Principles, Measurements, and Applications*, VCH, New York, 1994 (see R.C. Navarrette, L.E. Scriven, C.W. Macosko, *J. Colloid Interface Sci.*, 180 (1996) 200 for more precise details).
- [3] C.D. Han, *Multiphase Flow in Polymer Processing*, Academic Press, New York, 1981.
- [4] E.C. Bingham, *Bull. US Bur. Stand.* 13 (1916) 309.
- [5] V. Illingworth (Ed.), *Penguin Dictionary of Physics*, Penguin Books, London, 1991.
- [6] S.P. Parker (Ed.), *McGraw-Hill Dictionary of Science and Technology*, 4th ed., McGraw-Hill, New York, 1989.
- [7] M. Robinson (Ed.), *Chambers 21st Century Dictionary*, W.R. Chambers, Edinburgh, 1996.
- [8] T.C. Collocott (Ed.), *Chambers Dictionary of Science and Technology*, W.R. Chambers, Edinburgh, 1971.
- [9] D.M. Considine (Ed.), *Van Nostrand's Science Encyclopaedia*, 5th ed., Van Nostrand, New York, 1968.
- [10] H.A. Barnes, J.F. Hutton, K. Walters, *An Introduction to Rheology*, Elsevier, Amsterdam, 1989.
- [11] T. Schwedoff, *Rapp. Congress Phys.* 1 (1900) 478.
- [12] E.O. Kramer, R.V. Williamson, *J. Rheol.* 1 (1929) 76.
- [13] E.C. Bingham, *Fluidity and Plasticity*, McGraw-Hill, New York, 1922.
- [14] M. Reiner, *Ten Lectures on Theoretical Rheology*, Rubin Mass, Jerusalem, 1943.
- [15] M. Reiner, *Deformation Strain and Flow*, H.K. 3rd ed., Lewis, London, 1969.
- [16] R. Houwink, The yield value, chp. 4, *Second Report on Viscosity and Plasticity*, N.V. Noord-Hollandische Uitgeversmaatschappij, Amsterdam, 1938.
- [17] G.W. Scott Blair, *A Survey of General and Applied Rheology*, 2nd ed., Pitman, London, 1949.
- [18] G.W. Scott Blair, *Nature* 149 (1942) 702.
- [19] E.N. da C. Andrade, *Viscosity and Plasticity*, Heffer, Cambridge, 1947.
- [20] V.G.W. Harrison (Ed.), *Rheology*, Butterworth, London, 1954.
- [21] C.C. Mills (Ed.), *Rheology of Disperse Systems*, Pergamon Press, Oxford, 1959.
- [22] P. Sherman, *Industrial Rheology*, Academic Press, London, 1970.
- [23] M. Harnett, R.K. Lambert, J. Lelievre, A.K.H. Macgibbon, M.W. Taylor, in: P. Moldenaers, R. Keunings (Eds.), *Theoretical and Applied Rheology*, Proc. 11th International Rheology Congress, Brussels, Elsevier, Amsterdam, 1992, pp. 708–710.
- [24] P. Pacor, L.H. Lander, J.M.P. Papenhuijzen, *Rheol. Acta* 9 (3) (1970) 455.
- [25] W.L. Wilkinson, *Non-Newtonian Fluids—Fluid Mechanics, Mixing and Heat Transfer*, Pergamon Press, Oxford, 1960.
- [26] J. Harris, *Rheology and non-Newtonian flow*, Longmans, Green and Co., London, 1977.
- [27] E. Buckingham, *Proc. Am. Soc. Test. Mater.* 21 (1921) 1154.
- [28] B.O.A. Hedstrom, *Ind. Eng. Chem.* 44 (1948) 651.
- [29] R.N. Weltmann, *Ind. Eng. Chem.* 48 (1956) 386.
- [30] R.B. Bird, G.C. Dai, B.J. Yarusso, *Rev. Chem. Eng.* 1 (1) (1982) 1.
- [31] J.G. Oldroyd, *Proc. Camb. Phil. Soc.*, 43 (1947) 100; 43 (1947) 383; 43 (1947) 396; 43 (1947) 521; 44 (1948) 200; 44 (1948) 214; 45 (1949) 595; 47, (1951) 410.
- [32] H.A. Barnes, K. Walters, in: B. Mena et al., *Advances in Rheology* (Eds.) Universidad Nacional Autonoma de Mexico, Mexico City, 1984, Proc. 9th International Congress on Rheology, Acapulco, October 1984, vol. 4, p. 45.
- [33] H.A. Barnes, *Theoretical and Applied Rheology*, in: P. Moldenaers, R. Keunings (Eds.), Proc. XIth Int. Congr. Rheology, Elsevier, Amsterdam, 1992, pp. 576–578.
- [34] J.P. Hartnett, R.Y.Z. Hu, *J. Rheol.* 33 (4) (1989) 671.
- [35] G. Astarita, *J. Rheol.* 34 (2) (1990) 275.
- [36] I. Evans, *J. Rheol.* 36 (7) (1992) 1313.
- [37] D.C-H. Cheng, Yield stress: a time-dependent property and how to measure it, Report No. LR 540 (MH), Warren Spring Laboratory, Department of Industry, UK, ISBN 0 85624 395 7, August 1985.
- [38] Q.D. Nguyen, D.V. Boger, *Ann. Rev. Fluid Mech.* 24 (1992) 47.
- [39] H.A. Barnes, *J. Non-Newtonian Fluid Mech.* 56 (1995) 221.

- [40] D. De Kee, C.F. Chan Man Fong, *J. Rheol.* 37 (4) (1993) 775.
- [41] R.D. Spaans, M.C. Williams, *J. Rheol.* 39 (1) (1995) 241.
- [42] J. Ferguson, Z. Kemplowski, *Applied Fluid Rheology*, Elsevier Applied Science, Barking, UK, 1991.
- [43] R.W. Whorlow, *Rheological Techniques*, 2nd ed., Ellis Horwood, Chichester, UK, 1992.
- [44] A.Ya. Malkin, *Rheology Fundamentals*, ChemTec Publishing, Toronto-Scarborough, 1994.
- [45] S.S. Davis, J.J. Deer, B. Warburton, *J. Sci. Instrum. (J. Phys. D)* 2 (1) (1968) 933.
- [46] Anon., Promotional literature on the PCL Deer Variable Shear Stress Rheometer, circa 1970s.
- [47] J.G. Oldroyd, D.J. Strawbridge, B.A. Toms, *Proc. Phys. Soc. B* 64 (1951) 44.
- [48] R.J. Mannheimer, *J. Rheol.* 35 (1) (1991) 113.
- [49] M. Mohseni, H. Kautola, D.G. Allen, *J. Ferment. Bioeng.* 83 (3) (1997) 281.
- [50] L. Leongpoi, D.G. Allen, *Biotechnol. Bioeng.* 40 (3) (1992) 403.
- [51] C.Y. Chang, P.A. Smith, *Particul. Sci. Technol.* 14 (2) (1996) 165.
- [52] J. Keating, D.J. Hannant, *J. Rheol.* 33 (7) (1989) 1011.
- [53] Y.S. Lin, T.J. Liu, N.J. Chu, *J. Appl. Polym. Sci.* 42 (6) (1991) 1767.
- [54] B.R. Stanmore, D.W. Page, *Powder Technol.* 72 (2) (1992) 167.
- [55] R.M. Turian, T.W. Ma, F.L.G. Hsu, D.J. Sung, *Powder Technol.* 93 (3) (1997) 219.
- [56] P.V. Liddell, D.V. Boger, *J. Non-Newtonian Fluid Mech.* 63 (2–3) (1996) 235.
- [57] J.A. Yanez, T. Shikata, F.E. Lange, *J. Am. Ceram. Soc.* 79 (11) (1996) 2917.
- [58] V. Ramakrishnan, S.G. Malghan, *J. Am. Ceram. Soc.* 79 (10) (1996) 2567.
- [59] N.J. Alderman, G.H. Meeten, J.D. Sherwood, *J. Non-Newtonian Fluid Mech.* 39 (3) (1991) 291.
- [60] J.F. Steffe, E. W. Ford, *J. Texture Stud.* 16 (1985) 179.
- [61] W.L. Wilson, R.A. Speers, M.A. Tung, *J. Texture Stud.* 24 (3) (1993) 269.
- [62] B. Yoo, M.A. Rao, *J. Texture Stud.* 25 (4) (1994) 421.
- [63] B. Yoo, M.A. Rao, *J. Food Sci.* 60 (4) (1995) 777.
- [64] J.L. Briggs, J.F. Steffe, *Z. Ustunol, J. Dairy Sci.* 79 (4) (1996) 527.
- [65] L.T. Wardhaugh, D.V. Boger, *J. Rheol.* 35 (6) (1991) 1121.
- [66] H. Pinkerton, G. Norton, *J. Volcanol. Geoth. Res.* 68 (4) (1995) 307.
- [67] J. Yan, A.E. James, *J. Non-Newtonian Fluid Mech.* 70 (3) (1997) 237.
- [68] H.A. Barnes, J.O. Carnali, *J. Rheol.* 34 (6) (1990) 841.
- [69] N.Q. Dzuy, D.V. Boger, *J. Rheol.* 27 (1983) 321.
- [70] M. Keentok, *Rheol. Acta* 21 (1982) 325.
- [71] J. Yongxing, Z. Ning, Z. Huifeng, *Theoretical and Applied Rheology*, in: P. Moldenaers, R. Keunings (Eds.), *Proc. XIth Int. Congr. Rheology*, Brussels, Belgium, 1992, Elsevier, Amsterdam, p. 975.
- [72] T.A. Suck, K. Ehrmann, M-L. Suck, *Theoretical and Applied Rheology*, in: P. Moldenaers, R. Keunings (Eds.), *Proc. XIth Int. Congr. Rheology*, Brussels, Belgium, 1992, Elsevier, Amsterdam, p. 1003.
- [73] D. Quemada, *Advances in Rheology*, vol. 2, Fluids, B. Mena et al. (Eds.), Universidad Nacional Autonoma de Mexico, Mexico City, 1984, p. 571.
- [74] R. Buscall, *Theoretical and Applied Rheology*, in: P. Moldenaers, R. Keunings (Eds.), *Proc. XIth Int. Congr. Rheology*, Brussels, Belgium, 1992, Elsevier, Amsterdam, pp. 591–594.
- [75] H.A. Barnes, *Proceedings of the 1992 IChemE Research Event*, IChemE., Rugby, 1992, ISBN 0 85295 290 2, pp. 24–29.
- [76] A. Bradbury, J.W. Goodwin, R.W. Hughes, *Langmuir* 8 (1992) 2863.
- [77] A.E. James, D.J.A. Williams, P.R. Williams, *Rheol. Acta* 26 (1987) 437.
- [78] Y.K. Leong, D.V. Boger, P.J. Scales, T.W. Healy, R. Buscall, *J. Chem. Soc., Faraday Trans.* 89 (14) (1993) 2473.
- [79] Y.K. Leong, D.V. Boger, P.J. Scales, T.W. Healy, *J. Colloid Interface Sci.* 181 (2) (1996) 605.
- [80] Y.K. Leong, D.V. Boger, P.J. Scales, T.W. Healy, *Colloids Surf. A.* 95 (1) (1995) 43.
- [81] Y.K. Leong, *J. Chem. Soc., Faraday Trans.* 93 (1) (1997) 105.
- [82] P.C. Kapur, P.J. Scales, D.V. Boger, T.W. Healy, *AIChE J.* 43 (5) (1997) 1171.
- [83] R.M. Turian, M.K. Fakhreddine, K.S. Avramidis, *Fuel* 72 (9) (1993) 1305.
- [84] R.M. Turian, F.L. Hsu, K.S. Avramidis, D.J. Sung, R.K. Allendorfer, *AIChE J.* 38 (7) (1992) 969.
- [85] D. Panda, A. Parida, J.S. Murty, A.K. Mitra, *Int. J. Multiphase Flow* 20 (1) (1994) 171.

- [86] S.A. Mezzasalma, *J. Colloid Interface Sci.* 190 (2) (1997) 302.
- [87] S.A. Mezzasalma, D. Baldovino, *J. Colloid Interface Sci.* 180 (2) (1996) 413.
- [88] E.P. Luther, J.A. Yanez, G.V. Franks, F.F. Lange, D.S. Pearson, *J. Am. Ceram. Soc.* 78 (6) (1995) 1495.
- [89] G.V. Franks, B.V. Velamakanni, F.F. Lange, *J. Am. Ceram. Soc.* 78 (5) (1995) 1324.
- [90] M. Ohtsubo, A. Yoshimura, S. Wada, R.N. Yong, *Clays and Clay Miner.* 39 (4) (1991) 347.
- [91] E.M. Tracy, P.A. Smith, E.V. Morris, *J. Nucl. Mater.* 230 (1) (1996) 19.
- [92] T. Matsumoto, J. Chiba, H. Inoue, *Colloid Polym. Sci.* 270 (7) (1992) 687.
- [93] P. Snabe, P. Mills, *J. Phys.* III 6 (12) (1996) 1811.
- [94] D.J.A. Williams, P.R. Williams, *J. Coastal Res.* 5 (1989) 165.
- [95] A.E. James, D.J.A. Williams, P.R. Williams, in: J. Dronkers, C.N. van Leussen (Eds.), *Physical Processes in Estuaries*, Springer, Berlin, 1988, pp. 488–500.
- [96] J.F. Steffe, *Rheological Methods on Food Process Engineering*, Freeman Press, East Lansing, 1992.
- [97] D. Patel, Ph.D. Thesis, Birmingham University, UK, 1997.
- [98] T.P. Elson, D. Cheesman, A.W. Nienow, *Chem. Eng. Sci.* 41 (1986) 2555.
- [99] X.M. Zhang, Q.D. Nguyen, in: A. Ait-Kadi, J.M. Dealy, D.F. James, M.C. Williams (Eds.), *Proc. XIIth Int. Congr. Rheology*, Quebec, 1996, p. 560.
- [100] C. Picart, J.-M. Piau, H. Galliard, P. Carpentier, *J. Rheol.* 42 (1) (1998) 1.
- [101] G.R. Cokelet, E.W. Merrill, E.R. Gilliland, *Trans. Soc. Rheol.* 7 (1963) 303.
- [102] C.L. Morris, R.A. Gruppo, R. Shukla, *J. Lab. Clin. Med.* 118 (4) (1991) 332.
- [103] P. Dhar, V. Seshadri, G. Jayaraman, *Clin. Hemorheol.* 15 (5) (1995) 715.
- [104] Y.D. Shi, R. Agosti, P. Ticozzelli, *Clin. Hemorheol.* 16 (4) (1996) 559.
- [105] H.Q. Chen, G.H. Zhong, L. Li, *Biorheology* 28 (3–4) (1991) 177.
- [106] H.Q. Chen, D. Zhou, L. Li, *Clin Hemorheol.* 11 (6) (1991) 635.
- [107] M.E. Rogers, D.T. Williams, R. Niththyananthan, *Clin. Sci.* 82 (3) (1992) 309.
- [108] C. Tu, M. Deville, *J. Biomech.* 29 (1996) 899.
- [109] H.J. Frost, M.F. Ashby, *Deformation-Mechanism Maps*, Pergamon Press, Oxford, 1982.
- [110] M. Reiner, *Physics Today*, January 1964, p. 62.
- [111] E.R. Ivins, *J. Geophys. Res.-Solid Earth* 101 (1996) 28005.
- [112] M. Dragoni, A. Tallarico, *J. Volcanol. Geotherm. Res.* 74 (1996) 39.
- [113] M.A. Hofton, G.R. Foulger, *J. Geol. Res.-Solid Earth* 101 (25) (1996) 403.
- [114] F.F. Pollitz, I.S. Sacks, *J. Geol. Res.-Solid Earth* 101 (17) (1996) 771.
- [115] M. Nakada, *Geophys. J. Int.* 126 (1996) 829.
- [116] M.J. Adams, I. Aydin, B.J. Briscoe, S.K. Sinha, *J. Non-Newtonian Fluid Mech.* 71 (1997) 41.
- [117] M.J. Adams, B.J. Briscoe, S.K. Sinha, *Philosophical magazine A—physics of condensed matter defects and mechanical properties* 74 (5) (1996) 1225.
- [118] J. Briscoe, S.K. Biswas, S.K. Sinha, S.S. Panesar, *Tribol. Int.* 26 (3) (1993) 183.
- [119] M.J. Adams, S.K. Biswas, B.J. Briscoe, M. Kamyab, *Powder Technol.* 65 (1–3) (1991) 381.
- [120] M.J. Adams, B.J. Briscoe, M. Kamjab, *Adv. Colloid Interface Sci.* 44 (1993) 143.
- [121] N.V. Biba, H. Keife, U. Stahlberg, *J. Mater. Proc. Techn.* 36 (2) (1993) 141.
- [122] J.M. Dixon, R. Tirrul, *J. Struct. Geol.* 13 (1) (1991) 3.
- [123] G. Kobberger, G. Zulauf, *J. Struct. Geol.* 17 (7) (1995) 1055.
- [124] S.M. Liu, J.M. Dixon, *J. Struct. Geol.* 17 (6) (1995) 875.
- [125] F.G. Marques, P.R. Cobbold, *J. Struct. Geol.* 17 (4) (1995) 589.
- [126] A.M. Bragov, G.M. Grushevsky, A.K. Lomunov, *Exp. Mech.* 36 (3) (1996) 237.
- [127] H. So, Y.F. Lin, K.W. Huang, *J. Mater. Proc. Technol.* 66 (1–3) (1997) 39.
- [128] A. Segawa, T. Kawanami, *J. Mater. Proc. Technol.* 47 (3–4) (1995) 375.
- [129] Y.H. Moon, M.S. Chun, J.J. Yi, J.K. Kim, *Steel Res.* 64 (11) (1993) 557.
- [130] J.F. Dupuis, J.P. Villemaire, E. Felder, *J. Mater. Proc. Technol.* 43 (2–4) (1994) 237.
- [131] H. Sofuoglu, J. Rasty, *J. Energy Resources Technol.—Trans. ASME* 115 (1) (1993) 32.
- [132] H. Keife, *J. Mater. Proc. Technol.* 37 (1–4) (1993) 189.
- [133] H. Sasahara, T. Obikawa, T. Shirakashi, *Int. J. Jpn. Soc. Precis. Eng.* 28 (2) (1994) 123.
- [134] S.Q. Xu, Y. Fu, *J. Mater. Proc. Technol.* 69 (1–3) (1997) 208.

- [135] J.L. Chenot, P. Montmitonnet, A. Bern, C. Bertrandcorsini, *Comput. Methods Appl. Mech. Eng.* 92 (2) (1991) 245.
- [136] M. Meidert, M. Knoerr, K. Westphal, T. Altan, *J. Mater. Proc. Technol.* 33 (1–2) (1992) 75.
- [137] K. Mori, K. Osakada, H. Yamaguchi, *Int. J. Mech. Sci.* 35 (10) (1993) 879.
- [138] J. Schurz, *J. Rheol.* 36 (7) (1992) 319.
- [139] W.H. Herschel and R. Bulkley, *Proc. Am. Assoc. Test Mater.*, 26 (1926) 621; *Kollzeitschr.*, 39 (1926) 291.
- [140] S. Rossi, P.F. Luckham, Th. F. Tadros, *Proc. XIIth Int. Congr. Rheology*, in: A. Ait-Kadi, J.M. Dealy, D.F. James, M.C. Williams (Eds.), Quebec, 1996, pp. 450, 449.
- [141] H.M. Laun, *Xth Inter. Congress Rheology*, Sydney 1988, in: P.H.T. Uhlherr (Ed.), *Australian Society of Rheology*, 1988, vol. 1, pp. 37–42.
- [142] F. van Dieren, *Theoretical and Applied Rheology*, in: P. Moldenaers, R. Keunings (Eds.), *Proc. XIth Int. Congr. Rheology*, Brussels, Belgium, Elsevier, Amsterdam, 1992, p. 690.
- [143] H.M. Princen, A.D. Kiss, *J. Colloid Sci.* 128 (1989) 176.
- [144] T. Benezech, J. F. Maingonnat, *Theoretical and Applied Rheology*, in: P. Moldenaers, R. Keunings (Eds.), *Proc. XIth Int. Congr. Rheology*, Brussels, Belgium, Elsevier, Amsterdam, 1992, pp. 693–695.
- [145] S.N. Battacharya, S.H. Javadpour, *Theoretical and Applied Rheology*, in: P. Moldenaers, R. Keunings (Eds.), *Proc. XIth Int. Congr. Rheology*, Brussels, Belgium, Elsevier, Amsterdam, 1992, pp. 896–898.
- [146] B.J. Briscoe, G.M. Corfield, C.J. Lawrence, M.J. Adams, *Trans. IChemE* 76 (1998) 16.
- [147] G.G. Lipscomb, M.M. Denn, *J. Non-Newtonian Fluid Mech.* 14 (1984) 337.
- [148] V.K. Hohenemser, W. Prager, *ZAMM* 12 (1932) 216.
- [149] R. Hill, *The Mathematical Theory of Plasticity*, OUP, London, 1950.
- [150] S.D.R. Wilson, *Theoretical and Applied Rheology*, in: P. Moldenaers, R. Keunings (Eds.), *Proc. XIth Int. Congr. Rheology*, Brussels, Belgium, Elsevier, Amsterdam, 1992, p. 242.
- [151] P. Szabo, O. Hassager, *Theoretical and Applied Rheology*, in: P. Moldenaers, R. Keunings (Eds.), *Proc. XIth Int. Congr. Rheology*, Brussels, Belgium, Elsevier, Amsterdam, 1992, pp. 219–221.
- [152] C.R. Beverly, R.I. Tanner, *Theoretical and Applied Rheology*, in: P. Moldenaers, R. Keunings (Eds.), *Proc. XIth Int. Congr. Rheology*, Brussels, Belgium, Elsevier, Amsterdam, 1992, p. 297.
- [153] K.J. Hammad, G.C. Vradis, *Int. Comm. Heat Mass Transf.*, 23 (1996) 599; 39 (1996) 1555.
- [154] A.O. Nieckele, M.F. Naccache, P.R.S. Mendes, *J. Non-Newtonian Fluid Mech.* 75 (1998) 43.
- [155] S.S. Abdali, E. Mitsoulis, N.C. Markatos, *J. Rheol.* 36 (2) (1992) 389.
- [156] T.C. Papanastasiou, *J. Rheol.* 31 (1987) 385.
- [157] T. Coupez, M.A. Zine, *Progress and Trends in Rheology IV*, in: C. Gallegos (Ed.), *Steinopff, Proc. 4th European Rheology Conference*, Darmstadt, 1994, pp. 341–343.
- [158] F. Yang, *Rheol. Acta* 37 (1998) 68.
- [159] E. Hatschek, *The Viscosity of Colloidal Solutions*, chp. 12 of *The Viscosity of Liquids*, Van Nostrand, Princeton, NJ, 1928.
- [160] B.D. Coleman, H. Markovitz, W. Noll, *Viscometric Flows of Non Newtonian Fluids—Theory and Experiment*, Springer, Berlin, 1966, p.90.
- [161] H.A. Barnes, *Dispersion Rheology 1980, a Survey of Industrial Problems and Academic Progress*, R. Soc. Chem., Industrial Division, Burlington House, London, 1981, p. 31.
- [162] A. Bondi, in: F.R. Eirich (Ed.), *Rheology of lubrication and lubricants*, chp. 12 of *Rheology, Theory and Applications*, vol. 3, Academic Press, New York, 1960.