



Open Research Online

The Open University's repository of research publications
and other research outputs

Characterisation of a CMOS charge transfer device for TDI imaging

Journal Article

How to cite:

Rushton, J.; Holland, A.; Stefanov, K. and Mayer, F. (2015). Characterisation of a CMOS charge transfer device for TDI imaging. *Journal of Instrumentation*, 10(3), article no. C03027.

For guidance on citations see [FAQs](#).

© 2015 IOP Publishing Ltd and Sissa Medialab srl

Version: Proof

Link(s) to article on publisher's website:

<http://dx.doi.org/doi:10.1088/1748-0221/10/03/C03027>

<http://iopscience.iop.org/1748-0221/10/03/C03027>

Copyright and Moral Rights for the articles on this site are retained by the individual authors and/or other copyright owners. For more information on Open Research Online's [data policy](#) on reuse of materials please consult the policies page.

oro.open.ac.uk

Characterisation of a CMOS Charge Transfer Device for TDI Imaging

J. Rushton^{a*}, A. Holland^a, K. Stefanov^a and F. Mayer^b

^a*Centre for Electronic Imaging, The Open University,
Walton Hall, Milton Keynes, MK7 6AA, United Kingdom*

^b*e2v Semiconductors,
Avenue de Rochepleine, BP123, 38521 Saint Egrève, France
E-mail: joseph.rushton@open.ac.uk*

ABSTRACT: The performance of a prototype true charge transfer imaging sensor in CMOS is investigated. The finished device is destined for use in TDI applications, especially Earth-observation, and to this end radiation tolerance must be investigated. Before this, complete characterisation is required. This work starts by looking at charge transfer inefficiency and then investigates responsivity using mean-variance techniques.

KEYWORDS: TDI; CMOS; Charge Transfer; Mean Variance; Photon Transfer.

*Corresponding author.

Contents

1. Introduction	1
1.1 CMOS Sensors for TDI	1
1.2 Implementing Charge Transfer in CMOS	2
2. Test Chip	2
3. Characterisation	2
3.1 Charge Transfer Inefficiency	2
3.2 CVF	3
3.3 X-ray Calibration	3
3.4 Charge Injection	4
3.5 Response to Illumination	4
3.6 Mean-Variance	4
4. Conclusions and Further Work	6

1. Introduction

1.1 CMOS Sensors for TDI

Time Delay and Integration (TDI) sensors are used to increase the Signal to Noise Ratio (SNR) and the sensitivity of image sensors when imaging fast moving objects. Applications include industrial process monitoring and Earth observation from aircraft or spacecraft. TDI works by summing the signal captured in different pixel rows as they are exposed sequentially to the same object or point. For an Active Pixel Sensor (APS) this process generally relies on first measuring the in-pixel charge and then performing the summation off-pixel. This means that any noise from the measurement is also summed. CCD sensors can perform TDI by clocking the accumulated charge from one pixel to the next directly (“true charge transfer”) while continuing the exposure and measuring the charge only once. While this imaging technique is well suited to CCDs, there are potential advantages to a successful CMOS implementation. The extra on-chip functionality afforded by CMOS technology and the lower power consumption make system design less complex. In addition it is easy to use a dedicated output amplifier per column, as opposed to the serial register and a single output amplifier configuration normally found in CCDs. This potentially allows for much higher line rates than standard CCDs. The absence of a serial register also relaxes the requirements for pixel to pixel Charge Transfer Efficiency (CTE) as the number of transfers equals the number of pixel rows (including transfer to the amplifier). Modern CMOS processes also allow for smaller pixel sizes.

1.2 Implementing Charge Transfer in CMOS

One of the main challenges to CCD style charge transfer on devices built on a CMOS process is that overlapping or tightly spaced gates are typically not available. This leaves a potential barrier or a pocket between gates which prevents complete transfer of charge. Doping implants can be used to overcome this limitation by altering the potential structure, as is the case for the test devices here. In spite of this, the CTE performance of sensors manufactured on CMOS processes is still below that of conventional CCDs. The subject of this work is a true charge transfer TDI device, manufactured on a 0.18 μm CMOS image sensor process, intended for Earth observation applications. The test devices were designed by e2v Semiconductors in order to evaluate multiple pixel designs and fabrication options before progressing to a full scale device.

For imaging devices destined for operation in space, the effects of exposing the device to radiation must be understood. Full characterisation before and after irradiation is required, particularly the CTE and the dark signal. This work forms part of the pre-irradiation characterisation carried out on the TDI CMOS test chips prior to a radiation campaign to be performed by the Centre for Electronic Imaging. The radiation campaign will concentrate on doses relevant to a Low Earth Orbit (LEO) space mission.

2. Test Chip

A number of pixel variants were incorporated on the test chips. Two variants, referred to as CCD-like and the Hammer Shape Pixel (HSP), each with pixel pitches of 7 μm or 13 μm , were studied. The Hammer Shape Pixel design and characterisation is described in [1]. This work looks at characterisation of the 13 μm CCD-like pixel device. The pixel design is a 4 phase CCD with doping implants between the gates to maintain smooth potential profile. Both surface and buried channel devices were produced.

The test devices comprise 40 pixel rows arranged in 8 blocks, with each block containing 8 columns of the same design. Charge is transferred through the 40 pixels during exposure and, after the readout node has been discharged to a reset voltage, transferred to the readout node. The readout node for the column is buffered and the output from each column can then be selected through a multiplexer to be measured by an off-chip ADC or oscilloscope. The voltage output has the same format as that of a CCD i.e. reset level followed by signal level.

Figure 1 shows a schematic of a single column within the pixel array. The output stage is repeated at the top and bottom of the column making the devices bidirectional. The output stage can also be used to inject charge into the pixels (through I_{INJ}) as shown on the left of the diagram. Figure 2 shows the pixel array on the test chip.

3. Characterisation

3.1 Charge Transfer Inefficiency

Figure 3 shows Charge Transfer Inefficiency (CTI) as measured using Extended Pixel Response (EPR) for the surface and buried channel designs. A surface channel offers the best peak CTI, whereas the buried channel design has consistent CTI over a wide signal range. While the CTI is

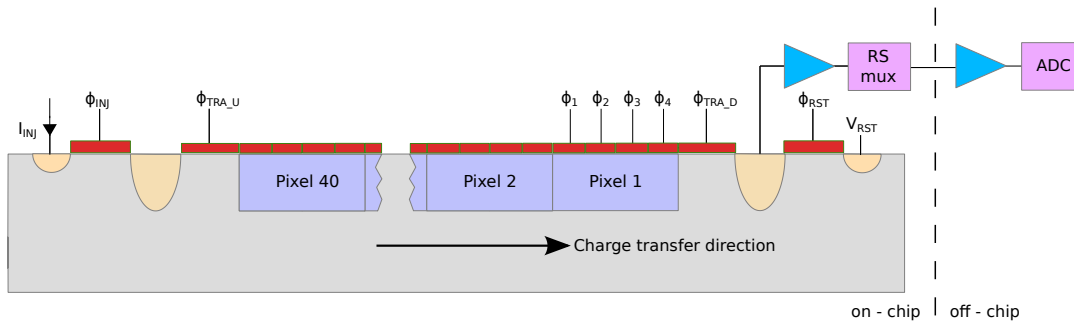

Figure 1. Simplified schematic of 40 pixel column and associated electronics.

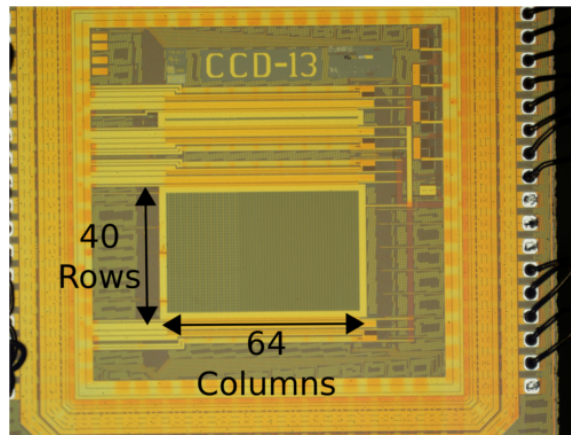

Figure 2. Photomicrograph of the test chip.

rather high compared to conventional CCDs, it is very promising considering the low number of transfers required in a TDI sensor.

3.2 CVF

The Charge to Voltage conversion Factor (CVF) is required to convert from output voltage or ADC units to units of electrons, and is an important calibration parameter of the sensor. It is essential for performance comparison with other devices and for relating measured performance with that of simulations. X-ray calibration, charge injection and statistical techniques (especially the photon transfer curve [2] [4]) are all useful tools to characterise CVF, although this can be complicated in CMOS by non-linear photoresponse [3]. CCD source followers generally use higher voltage power supplies which allow better linearity.

3.3 X-ray Calibration

The fact that only 40 pixels of the device can be used at once makes detecting X-ray events rather slow. With a 40 kBq ^{55}Fe source placed 5 mm from the device the detection rate is estimated to be around one X-ray per minute. The CTE of the devices studied here falls off dramatically at low signal levels. This makes accurate calibration using the few millivolts of signal from infrequent X-ray events rather difficult. This problem could in principle be solved by injecting charge prior

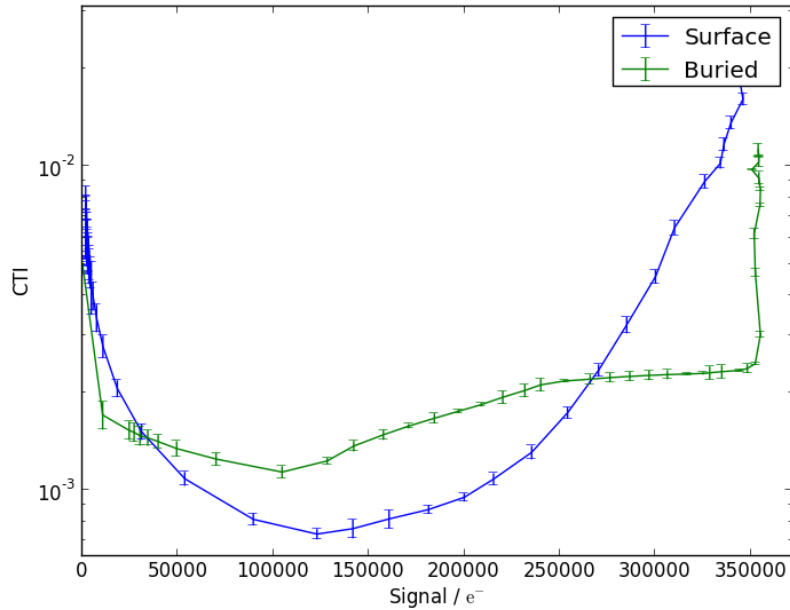

Figure 3. CTI against signal as measured in the buried and surface channel devices.

to collection of the X-ray such that the device is operating mid-signal, with a "fat zero", where the CTE is good.

3.4 Charge Injection

CVF can be measured using charge injection or under illumination. For charge injection the current required to sustain the injection charge over time is measured and converted to units of electrons per pixel. Alternatively the reset drain current can be measured. In either case the output voltage is also measured. The two methods give very similar results. Results using charge injection are shown in Figure 4. The current was measured using a Keithley 486 picoammeter and the output voltage measured with Correlated Double Sampling (CDS) using an AD7980 16-bit ADC. The CVF can then be calculated knowing the pixel rate (12.5 kHz in this case - although at least 50 kHz is possible with this device) and the injection duty cycle. The measured CVF in the linear region (up to around 2.1 V output voltage) is $6.25 \mu\text{V}/e^-$.

3.5 Response to Illumination

Response of the sensors to light was measured using an LED. Figure 5 shows signal against integration time under constant illumination. The curve is generated by using only data from a single pixel in the array. Results for other pixels in the array were very similar.

3.6 Mean-Variance

Mean-variance curves are shown in Figure 6. Each data point is calculated by taking the mean and variance of the signal in a single pixel over 100 frames, since the imaging area is small. Since the

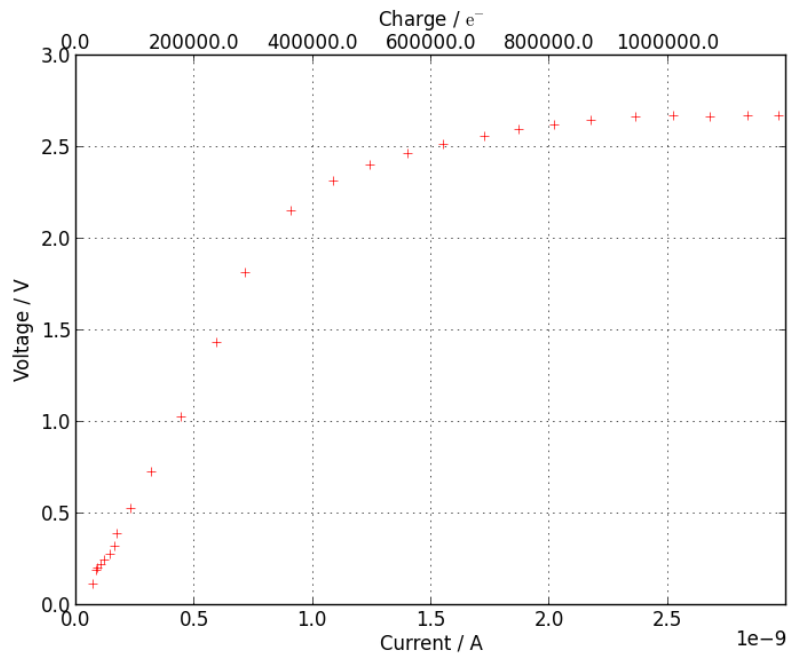

Figure 4. Output signal measured against charge injection current.

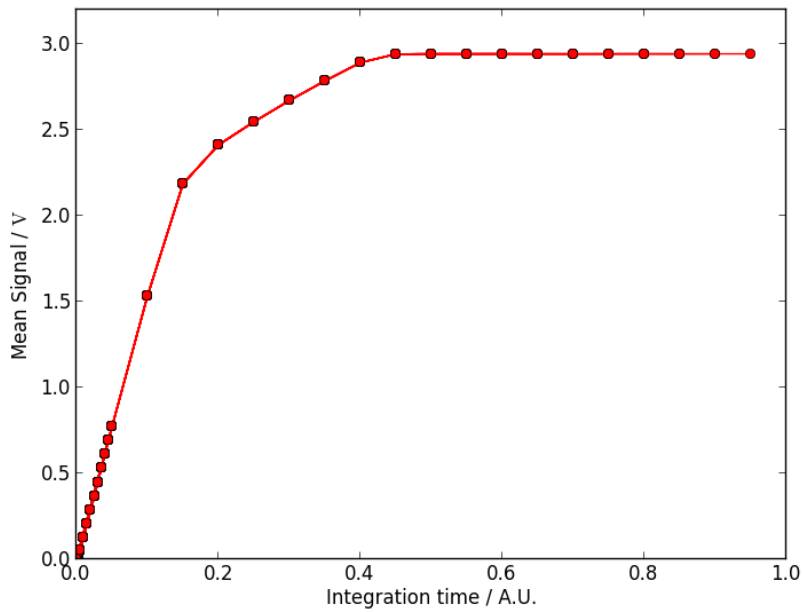

Figure 5. Signal vs. illumination.

data was taken from a single pixel, there is no fixed pattern noise and consequently the variance is shot-noise limited up to full well. The CVF of $6.25 \mu\text{V}/e^-$ as extracted from mean-variance data

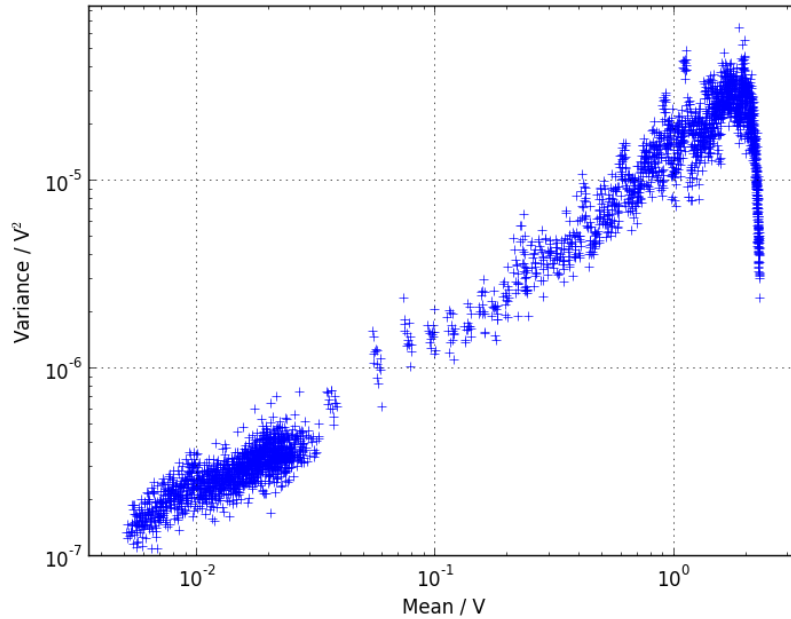

Figure 6. Mean-variance curve.

is in good agreement with the CVF measured using charge injection.

4. Conclusions and Further Work

This work is part of the full characterisation of the new TDI CMOS image sensors, as required prior to a radiation campaign. The charge transfer CMOS devices studied here show promising performance in terms of CTE. The forthcoming radiation study will assess the suitability of such devices for space applications.

Acknowledgments

The authors would like to thank James Endicott, Frederic Barbier and Henri Bugnet at e2v Semiconductors for their assistance in using the test devices. This work is partly funded by STFC.

References

- [1] F. Mayer et al., *First Measurements of True Charge Transfer TDI (Time Delay Integration) Using a Standard CMOS Technology*, in proceedings of *International Conference on Space Optics*, 2012
- [2] E. A. H. Allanwood et al., *Point-spread function and photon transfer of a CCD for space-based astronomy*, in proceedings of *SPIE 8860, UV/Optical/IR Space Telescopes and Instruments: Innovative Technologies and Concepts VI*, September 26, 2013
- [3] B Pain and B. R. Hancock, *Accurate estimation of conversion gain and quantum efficiency in CMOS imagers*, in proceedings of *SPIE 5017, Sensors and Camera Systems for Scientific, Industrial, and Digital Photography Applications IV*, May 14, 2003

[4] J. Janesick, *Photon Transfer $\lambda \rightarrow DN$* , SPIE Press, Bellingham, WA 2007