

# INVESTIGATION OF CENTRAL REGION DESIGN OF 10 MeV AVF CYCLOTRON

M.M. Afkhami Karaei, H. Afarideh, R. Solhju, S. Azizpourian  
Amirkabir University of Technology (AUT), Department of Physics, Tehran, Iran

J.S. Chai, M. Ghergherehchi<sup>†</sup>  
Sungkyunkwan University (SKKU), School of Information and Communication Engineering,  
Seoul, South Korea

## Abstract

Recently, studies on the central region of 10 MeV AVF Cyclotron have been done at Amirkabir University of Technology. In this study, the aim of the cyclotron design is to accelerate the ions up to 10 MeV energy. The cyclotron consist of four sector magnets and 2 RF cavities which will be operated at 71 MHz. The internal PIG ion source is used in this cyclotron. The purpose of this work is to investigate the behavior of trajectories of ions in the magnetic and electric fields at the center of the cyclotron. The electric and magnetic field distribution was designed by OPERA-3DTOSCA. In order to solve the equation of motion, numerical code was written in C++ program that used the conventional Rung-Kutta method. The obtained results of simulation were the horizontal and vertical motion of an ion in the center of cyclotron, and motion of the center of the orbits.

## INTRODUCTION

The purpose of manufacturing 10 MeV Amirkabir University of Technology produced Fluor-18. The cyclotron contains some component to produce an electric field, magnetic field and injection particle. Component of central region shows in Fig. 1. Beam injection by an internal ion source PIG [1] was carried out. H- Beam with zero kinetic energy produced by the ion source, these particles by the puller that located at a certain distance from the ion source were pulled out due to potential difference between these two points. The primary particles begin to move and primary energy particles from this method will be provided [2]. Voltage of Dummy Dees and pullers are zero and 42 keV respectively, particles that accelerated in a first step and don't have any collection with a body of cyclotron now again accelerated. Continues acceleration of particles performed by a potential difference between the central part of the liner and central part of Dees. Due to the beam dynamic depended to the early turns, set of electric and magnetic field geometry and initial condition of particle is very important. If the central region was not properly designed, could not be expected that particles extracted from cyclotron. Numerical code was written in C++ program that used the conventional Rung-Kutta method and initial condition of particles and electric and magnetic distribution to calculate the trajectory of single particle.

<sup>†</sup>m.ghergherehchi@gmail.com

## THE METHOD OF CALCULATING OF THE BEAM TRAJECTORY

A code for calculation of particle trajectory in the central region of cyclotron, written by using C++ language. Electric and magnetic field calculated by OPERA-3D-TOSCA.

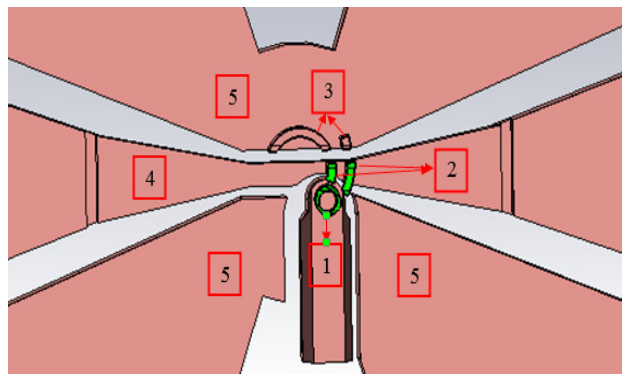

Figure 1: geometry of electric field in central region 1) head of ion source, 2) pullers, 3) dummy Dees, 4) central part of Dee, 5) central part of liner.

Results of TOSCA extracted and imported in to C++ code. C++ code calculated equation of motion according to the electric and magnetic field data's and initial condition that determined. Equation of motion that used in C++ code followed Eqs. (1), (2), and (3) [3].

$$\frac{d\vec{r}}{dt} = \frac{\vec{p}}{m\gamma} \tag{1}$$

$$\frac{d\vec{p}}{dt} = q(\vec{E} \cos \omega t + \frac{d\vec{r}}{dt} \times \vec{B}) \tag{2}$$

$$\frac{dW}{dt} = \vec{F} \cdot \vec{v} = \frac{d\vec{p}}{dt} \cdot \frac{d\vec{r}}{dt} \tag{3}$$

Initial condition of beam motion in central region of cyclotron 10 MeV and specification of cyclotron shown in Table1. Electric and magnetic fields related to the position determined by the C++ code and entered into the calculations when the particle is in any position.

Table 1: Initial Condition of Particle and Specification of Cyclotron

Parameter	Value
Initial energy of particle	0 keV
The initial coordinates of the particle in Cartesian coordinates	0, -7.36, 15.32 mm
Dee width	40°
Number of sectors	4
RF frequency	71 MHz
The magnetic field in the center of the cyclotron	1.18 T

Figure 2 shows the geometry of the magnetic field and poles in the center of the cyclotron. This geometry imported to the TOSCA, after calculation and optimization of the geometry, extracted data's from it. Distribution of magnetic field in center of 10 MeV cyclotron shows in Fig. 3.

In Fig. 1 the geometry of electric field and effective component in electric field is shown. The effective components of the electric field in central region included head of ion source, pullers, dummy Dees, central part of Dee and central part of liner. Potential of pullers and central part of Dee are 42 kV and potential of other components are zero. This geometry imported to the TOSCA and calculated electric potential with electro static solver of Opra3d.

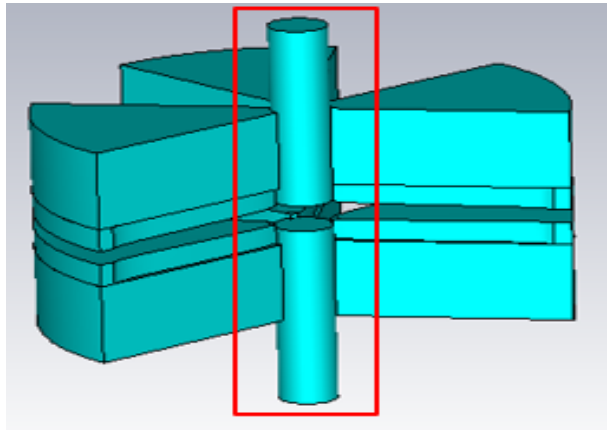

Figure 2: geometry magnetic field in central region.

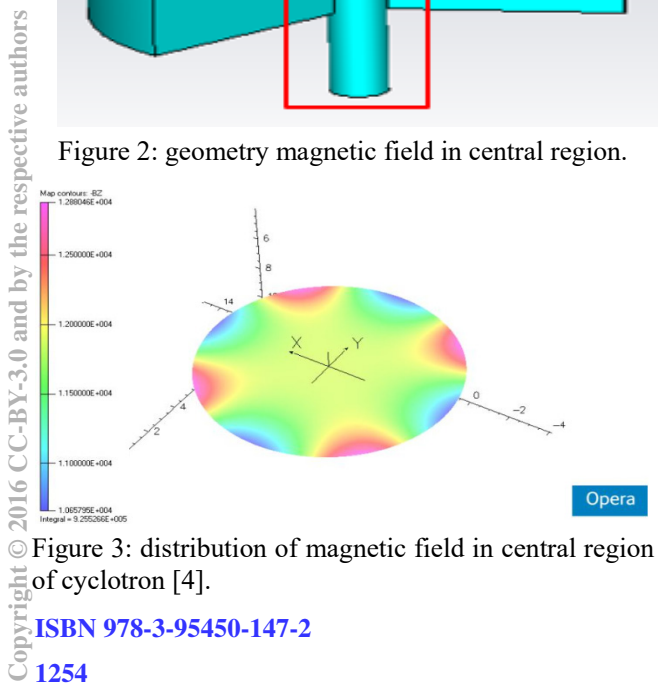

Figure 3: distribution of magnetic field in central region of cyclotron [4].

Electric potential data imported to the C++ code and electric field calculated by it. Electric potential distribution of this geometry is shown in Figure 4.

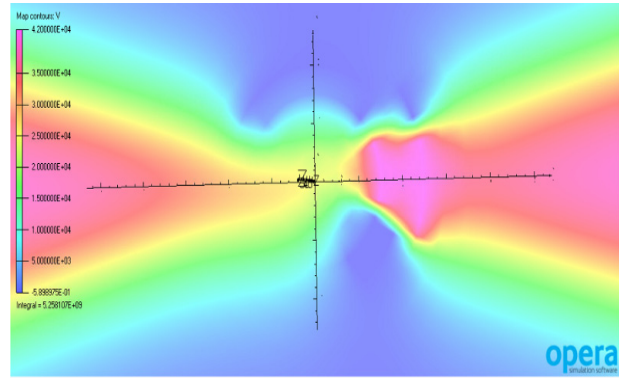

Figure 4: distribution of electric field in central region.

Electric and magnetic field and Primary condition of particle including phase, energy and position are determined. With frequent changes in the initial condition of the particle, tested numerical calculation by using C++ code. If we have not received to the appropriate beam dynamic, geometry of electric field and distance of poles were changed. Finally, with optimized geometry and initial condition, horizontal and vertical beam trajectory are achieved.

### BEAM TRAJECTORY

In Figs. 5 and 6 horizontal and vertical beam trajectory in central region, respectively, are showed. As can be seen in Table 1, the initial energy of the particle is zero. 300° and 308° are acceptable initial phases for beam trajectory in central region.

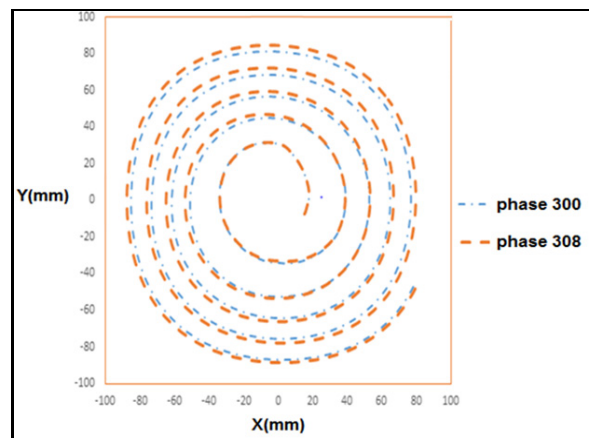

Figure 5: particle trajectories for the first 5 turns with phase 300° and 308°.

The vertical motion of the particle can be seen in Fig. 6. Particle can't violations vertical direction of ±9.5 mm, because it will collide to the body of the cyclotron. As can be seen without collision to the body of the cyclotron, the particle has continued on its path.

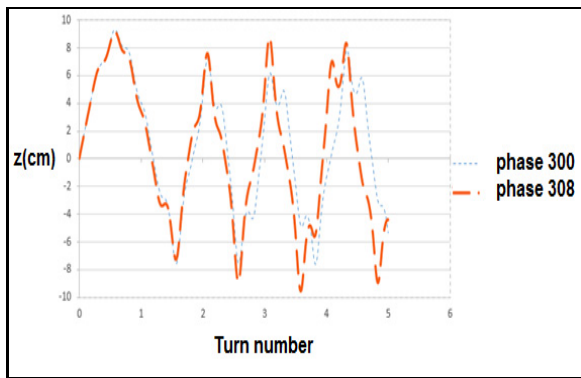

Figure 6: vertical beam motion for the first 5 turns with phase 300° and 308°

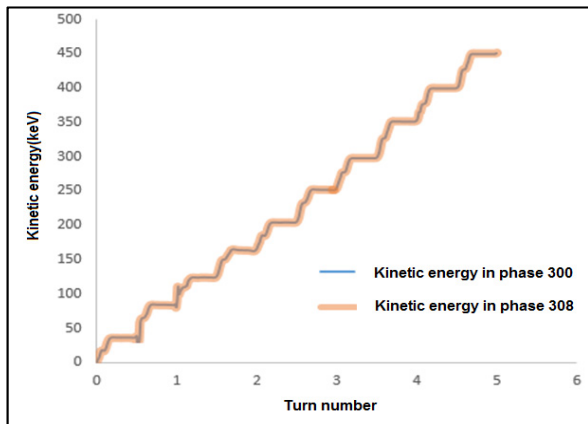

Figure 7: increasing of Kinetic energy for the first 5 turns with phase 300° and 308°.

Figure 7 shows a graph of kinetic energy of the particle. Kinetic energy of particle after 5 turns reached around 475 keV in phase 300 degree and 308 degree. Particle is placed on Equilibrium orbit of magnet in this energy and radius.

### CONCLUSION

Because of small space for components of central region of compact cyclotron, design of this region is very difficult. In the absence of appropriate design, probability of loss of H- beam is very high. Design of central region of cyclotron is done by using C++ code and the results are acceptable. The remainder of this study can be improved C++ code in order to investigation of charge particle in central region.

### REFERENCES

- [1] L. O. N. G. Jidong, *et al.* "Study on a cold-cathode H-PIG-type ion source", *Nuclear Science and Techniques* 24.4 40201-040201, 2013.
- [2] Q. I. N. Bin *et al.*, "Central region design for a 10 MeV internal ion source cyclotron", *Chinese Physics C* 33.8 682, 2009.
- [3] Yunxiang Huang, "A new design of the University of Manitoba cyclotron for D-ion acceleration and a study for the beam extraction from the Princeton University AVF cyclotron", (1988).
- [4] R. Solhju, *et al.* "Magnet design for the 10MeV AVF cyclotron accelerator", *Journal of the Korean Physical Society* 63.7 (2013): 1347-1350.