

# Evaluating the Reliability of Ambient-Assisted Living Business Processes

Ricardo Martinho<sup>1</sup>, Dulce Domingos<sup>2</sup> and Ana Respício<sup>3</sup>

<sup>1</sup>*Polytechnic Institute of Leiria and CINTESIS - Center for Health Technology and Services Research, Leiria, Portugal*

<sup>2</sup>*LaSIGE, Faculdade de Ciências, Universidade de Lisboa, Lisboa, Portugal*

<sup>3</sup>*Centro de Matemática, Aplicações Fundamentais e Investigação Operacional, Faculdade de Ciências, Universidade de Lisboa, Lisboa, Portugal*

**Keywords:** Ambient-Assisted Living, Reliability, Business Processes, BPMN.

**Abstract:** Ambient-Assisted Living (AAL) systems provide a wide range of applications in order to improve the quality of life of patients. These systems commonly gather several components such as sensors, gateways, Information Systems or even actuators. Reliability of these components is of most importance, mainly due to the impact that a failure can have on a monitored patient. In spite of the existing reliability evaluations and countermeasures that can be associated with an AAL system component, we need to take into account the overall reliability for the several activities and interactions that exist between all the AAL system components, for each time a certain value is registered or a certain alert is triggered. In this paper, we propose a new approach to calculate the overall reliability of an AAL system. We take a Business Process Management (BPM) approach to model the activities and interactions between AAL components, using the Business Process Model and Notation (BPMN) standard. By extending the BPMN standard to include reliability information, we can derive the overall reliability value of a certain AAL BPMN process, and help healthcare managers to better allocate the appropriate resources (including hardware or health care professionals) to improve responsiveness of care to patients.

## 1 INTRODUCTION

The major purpose of Ambient-Assisted Living (AAL) systems is to improve the quality of life and care responsiveness for patients at risk while staying at their homes and performing their normal daily routines (Islam et al., 2015). AAL provides them with an overall surveilled environment, allowing the delivery of care where and when needed, and also supporting caregivers, families and care organizations.

Applications of AAL not only provide continuous health monitoring through, for instance, vital signs recording for medical history analyses, but also play a major role in detecting emergency situations. In turn, caregivers and/or other health professionals can better organize their care business processes by receiving alerts and actuating when needed, and with the appropriate resources. Some AAL applications can even replace (self) care activities, such as auto injecting insulin when blood sugar values increase at a certain rate.

Although many times associated with support in

assisting elderly people (see for instance H2020 calls of European Commission), AAL systems can also be used in patients suffering from chronic diseases such as diabetes, asthma and heart attacks. Therefore, the impact of a less reliable system can range from a false alarm transmitted to a certain caregiver and/or emergency unit service, to serious patient injury due to wrong, delayed or even non-delivered care.

Current research works and industry products related with AAL and overall to Internet of Things (IoT) applied to healthcare already provide redundancy checks and alerts to prevent greater impacts to patients using them (see, for instance, Parente et al., 2011; Siewiorek and Swarz, 2014). Nevertheless, these efforts to increase reliability are usually self-contained to some components of an AAL system, i.e., reliability is commonly evaluated for each component, regardless of its position in a certain sequence of activities to trigger some action (alert, register or even actuate).

In this work, we propose a new and consolidated approach to calculate the overall reliability of an AAL system, by using a Business Process

Management (BPM) approach and the Business Process Model and Notation (BPMN) (OMG, 2011) standard *de facto* for modelling AAL business processes. We consider each component of an AAL system as part of a business process containing essentially sensors, actuators and gateways, which interact through a sequence of activities, decision nodes and messages in order to produce alerts, to register values in a centralized (healthcare) Information System, or even to trigger actuators to provide immediate care. Since these interactions are usually subjected to several conditions, we model them as BPMN process models, in order to calculate their combined reliability. This way, we can derive the overall AAL system reliability, such as in the following example: a measure is taken by a heart rate sensor, transmitted through a network, evaluated through an Information System, and the appropriate alerts are triggered to prevent potentially fatal consequences for the patient.

This paper is organized as follows: section 2 presents background on AAL and a typical AAL system scenario modelled with BPMN. In section 3 we refer to related work on reliability applied to most common components of an AAL system, and in section 4 we explain how we include reliability information in an AAL BPMN process model, in order to calculate its overall reliability and how we apply the Stochastic Workflow Reduction (SWR) algorithm to compute the reliability of combined BPMN process elements. Section 5 presents an application scenario for the calculus of the overall reliability for a typical AAL BPMN business

process. Finally, section 6 concludes the paper and presents future work.

## 2 BACKGROUND

This section presents a typical AAL process model (see for instance the proposals of Bui and Zorzi (2011) and Dar et al. (2014)).

The AAL BPMN process model, as illustrated in Figure 1, uses a collaboration diagram with four pools, one for each participant or AAL component (Rodrigues et al., 2012; Rashidi and Mihailidis, 2013; Memon et al., 2014; and Islam et al., 2015).

The Body Area Network (BAN) sensor devices are used for monitoring vital signs, i.e., heart and body activity in this example (based on Parente et al., 2011). The heart activity is assessed through the heart rate, the blood oxygen, and the blood pressure, by using a heart rate monitor, a pulse oxymeter and a sphygmomanometer, respectively. The system monitors the body activity by using an accelerometer. While this process only uses sensors, BANs can also include actuators. For instance BAN devices can, on a diabetic patient, auto inject insulin through a pump, while monitoring the insulin level (Jara et al., 2011).

As defined in this process, sensors read values from the patient from time to time by using a timer and send them to the BAN gateway. The interaction between sensors and the BAN gateway can also be implemented through the request-request paradigm,

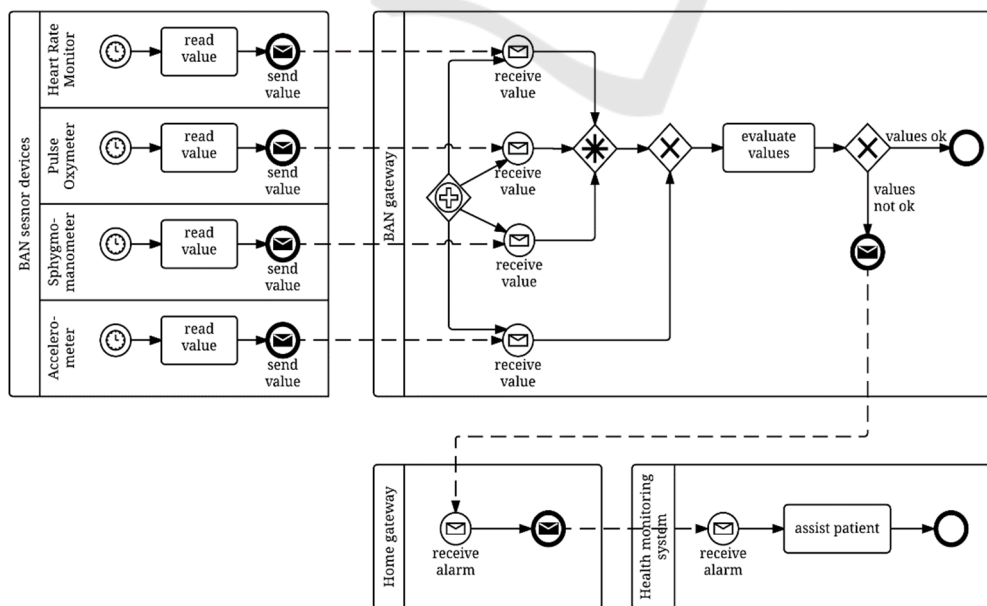

Figure 1: AAL BPMN process model.

where the BAN gateway starts the interaction asking for the values. Depending on sensor computational capabilities, they can also filter the data they transmit, sending only values that are considered relevant. However, for this reliability study, these differences are not significant.

The BAN gateway, another participant of the process, is responsible for the communication inside that BAN and to the home gateway. Besides it receives the values from sensors, it also validates, aggregates and analyses these values. The reception of sensor values is modelled with a BPMN Event-Based Exclusive Gateway. The information about heart rate should be provided by at least two out of three devices, and this behaviour is modelled with a BPMN Complex Gateway. After evaluating sensor values, the BAN gateway sends an alarm to the health monitoring system (HMS) to assist the patient, in case any emergent situation is detected. The communication between the BAN gateway and the HMS is performed through the home gateway. Smart phones or wireless routers can be used as home gateways. They communicate with the BAN gateway through wireless technologies (Bluetooth or WiFi, for instance) and provide the connectivity to the internet. From the point of view of the process model we could omit the Home gateway pool, as it does not define any business logic. However, this way, the participants of the process are coherent with the components of a generic AAL architecture and it simplifies the reliability study as the process includes all the components and connections.

Finally, with the health monitoring system, caregivers and physicians monitor patients remotely.

### 3 RELATED WORK

Koren and Krishna (2007) define *reliability of a system at time  $t$* , denoted by  $R(t)$ , as the probability of the system to be up continuously in time interval  $[0, t]$ . This metric is adequate for systems operating continuously, where a single momentary failure can have a high or even critical impact.

McNaull et al. (2012) discuss the quality issues of each component of an AAL system. BAN devices (sensors and actuators) reliability depends on their quality and manufacturer. According to the same authors, the mean-time between failures (MTBF) metric can be used to assess it. In addition, sensors data quality (accuracy) also interferes with reliability as anomalous values can be discarded, for instance, in BAN gateways. Quality of data depends on sensor calibration as well as on the correct use and

application of sensors. For instance, other heat sources can affect temperature sensors.

Parente et al. (2011) present a use case where they monitor the health of patients considering heart and body activities. The system uses a heart rate monitor, a pulse oxymeter, and a sphygmomanometer to monitor the heart activity. The body activity of patients is monitored with an accelerometer on knees and a motion detector in the room. Taking into account the required reliability of the system, the authors determine the minimal combinations of sensors the system needs. However they only use the information about the reliability of each device.

BAN gateways can be used to increase the reliability of the system. They may evaluate sensor data and detect anomalous and inconsistent values, considering the expected ones, which may have been established during the testing period of the AAL system (McNaull et al., 2012). In case of anomaly, erroneous sensor values are discarded and BAN gateways can request for new sensor values. If the problem persists, the BAN gateway can alert the health monitoring system. Another way to increase system reliability is by defining a fault tolerant behaviour for the BAN gateway.

Body sensors and actuators communicate with each other and with the BAN gateway using mostly wireless technologies, such as IEEE802.15.4 /ZigBee (IEEE, 2011). The latest international standard for wireless BAN (WBAN) is the IEEE802.15.6 (IEEE, 2012). Home and BAN gateways also communicate through wireless technologies (Bluetooth or WiFi, for instance).

Reliability of wireless networks depends on interferences of other devices; obstruction of the signal due to lifts or wall, and attenuation, i.e., the strength of the signal reduces during transmission. Baig et al. (2014) compare wireless transmitted data with manual recorded data and hospital collected data. They use a total of approximately 2500 transmissions of 30 hospitalized patients and they conclude that, in wireless transmitted data, losses vary from 20% (blood glucose) to 80% (blood pressure and heart rate). They also conclude that data losses were mainly due to distance and data transmission delays were due to poor signals, signal drops, connection loss and/or poor location.

Despite the evaluation of the reliability of each AAL component is crucial, it is not sufficient to study the overall system. This way, in the following, we present related work about computing reliability for composite tasks and/or even for the overall process.

Indeed, while reliability has been a major concern for networking, critical and real-time applications, as well as middleware (Parente et al., 2011; Siewiorek and Swarz, 2014); the increasing use of workflow, specifically, in more critical systems, justifies the works on workflow reliability.

In the context of workflow modelling, Cardoso (2002) defines task reliability as the probability that the components operate on users demand, following a discrete-time model. In this context, the failure rate of a task can be described by the ratio number of unsuccessful executions/ scheduled executions. The task reliability, denoted by  $R(A)$ , is the opposite of the failure rate, that is:

$$R(A) = 1 - \text{failureRate}(A).$$

In the same work, Cardoso proposes a predictive Quality of Service (QoS) model for workflows and web services that, based on atomic task QoS attributes, is able to estimate the QoS for workflows, considering the following dimensions: time, cost, reliability, and fidelity. To compute QoS for the overall workflow, the author developed the Stochastic Workflow Reduction algorithm, which applies a set of reduction rules to iteratively reduce construction workflow blocks until only one activity remains. The QoS metrics of the remaining activity corresponds to the QoS metrics of the process. Cardoso defines reduction rules for the following construction blocks: sequential, parallel, conditional, loop, fault tolerant, and network systems. He applies his proposal to the METEOR workflow management system (Krishnakumar and Sheth, 1995). To

estimate the reliability of web services compositions, Coppolino et al. (2007) generalize the Cardoso proposal, covering all the generic workflow patterns of van Der Aalst et al. (2003).

Within the WS-BPEL context, Mukherjee et al. (2008) compute the reliability of WS-BPEL processes taking into account most of the workflow patterns that WS-BPEL can express, while the method of Distefano et al. (2014) also incorporates advanced composition features such as fault, compensation, termination and event handling.

Using Unified Modeling Language (UML) models, Rodrigues et al. (2012) annotate system component interactions with their failure probabilities. They convert them into a formal executable specification, based on a probabilistic process algebra description language, which are executed on PRISM. This way, they can, for instance, identify the components that have the highest impact on the reliability system.

By focusing their work on BPMN, Respício and Domingos (2015) calculate the reliability of BPMN business processes by using the Stochastic Workflow Reduction method of Cardoso (Cardoso, 2002; Cardoso et al., 2004). To meet this goal, they extend BPMN with reliability information and they identify the BPMN process blocks for which they can apply one of the reduction rules.

The work we describe in this paper applies and extends the proposals of Respício and Domingos (2015) to evaluate the reliability of AAL processes.

Listing 1: BPMN extension for reliability - XML Schema.

```
<?xml version="1.0" encoding="UTF-8"?>
<xsd:schema xmlns:xsd="http://www.w3.org/2001/XMLSchema" xmlns="http://.../relybpmn"
xmlns:bpmn="http://www.omg.org/spec/BPMN/20100524/MODEL"
targetNamespace="http://.../relybpmn">
  <xsd:import namespace="http://www.omg.org/spec/BPMN/20100524/MODEL"
  schemaLocation="BPMN20.xsd"/>
  <xsd:group name="relyBPMN">
    <xsd:sequence>
      <xsd:element name="ReliabilityInformation" type="tReliabilityInformation"
        minOccurs="0" maxOccurs="1"/>
      <xsd:element name="Probability" type="tProbability" minOccurs="0"
        maxOccurs="1"/>
    </xsd:sequence>
  </xsd:group>
  <xsd:complexType name="tReliabilityInformation" abstract="false">
    <xsd:attribute name="requiredReliability" type="xsd:decimal"/>
    <xsd:attribute name="calculatedReliability" type="xsd:decimal"/>
  </xsd:complexType>
  <xsd:complexType name="tProbability" abstract="false">
    <xsd:attribute name="value" type="xsd:decimal"/>
  </xsd:complexType>
</xsd:schema>
```

### 4 RELIABILITY INFORMATION IN BPMN PROCESSES

To include reliability information in BPMN business processes we use the extension, whose XML Schema we present in Listing 1. The definition of this extension is based on the work proposed by Respício and Domingos (2015).

The extension has two elements. The first element, named `ReliabilityInformation`, has two attributes: the `requiredReliability` which defines the minimum accepted reliability value for the process or flow node, and the `calculatedReliability` which is the reliability of atomic activities and events (initialised with a pre-determined value) or the reliability for decomposable activities (sub-processes) and

processes computed using the SWR method of Cardoso (2002).

The second element is the `Probability`. The probability value is used with conditional `SequenceFlow` elements within conditional process or loop process blocks and defines the probability of the process execution path of taking them.

The reliability of processes is calculated with the SWR method of Cardoso (it is similar for decomposable activities). This method applies a set of reduction rules to the process, iteratively, until only one activity remains. The reliability of the remaining activity corresponds to the reliability of the process. Table 1 presents the application of the six reduction rules of Cardoso to BPMN, identifying the BPMN process blocks for which the reduction rules can be used (Respício and Domingos, 2015).

As the AAL BPMN process subject of our study

Table 1: Reliability of Reduced Block (Respício and Domingos, 2015).

	Initial Block	Reduced Block	Reliability of Reduced Block
Sequential			$R(AB) = R(A) * R(B)$
Parallel			$R(B1n) = \prod_{1 \leq i \leq n} R(Bi)$
Conditional			$R(B1n) = \sum_{1 \leq i \leq n} p_i R(Bi)$
Loop			$R(A') = \frac{(1 - p) R(A)}{1 - pR(A)}$
			$R(A') = R(A)^k$
Fault tolerant			$R(B1n) = \sum_{I_1=0,1 \dots I_2=0,1} (\phi(\sum_{i=1}^n I_i - k) * \prod_{i=1}^n (1 - I_i + (2I_i - 1)R(Bi)))$
Network			$R(A') = R(P1)$



also has events (see Figure 1), we use the same reduction rules for process blocks composed by events or activities, in an undifferentiated way.

In addition, when using reduction rules with collaboration diagrams, they are applied to the overall diagram by omitting pools and lanes. However, to overcome the limitations of the block structured approach of Cardoso, where one starting point and one ending point are needed, we transform the collaboration diagram by adding two new gateways. To have a unique starting point, we add an Exclusive Event-Based Gateway without any incoming sequence flows and with one outgoing sequence flow to each start event of the collaboration diagram. Similarly, to have a unique end point, we add an Inclusive or Merge Gateway with an incoming sequence flow from each end event and without any outgoing sequence flows (Ouyang et al., 2007).

## 5 RELIABILITY STUDY

This section presents a case study focusing on the reliability evaluation of the AAL process presented in section 2.

Initially, process designers set up the minimum accepted values for the reliability of activities and sub-processes (*requiredReliability*). The BPMN process model is then enriched, through the relyBPMN extension, considering these values as well as pre-estimated values of the attributes *calculatedReliability* (initialized with pre-estimated values for atomic activities and events) and *Probability*. Then, the SWR algorithm iteratively computes the *calculatedReliability* for sub-processes, reaching the reliability value for the overall process (the collaboration diagram).

In the following, we describe the application of this method to assess the reliability of the collaboration diagram displayed in Figure 1, considering different scenarios.

The experiment started by establishing a base case scenario and computing the corresponding reliability. After, a sensitivity analysis on the process reliability was made. The objective of this analysis was to evaluate the impact of changes in the individual reliability of separate elements on the reliability of the overall process. We made vary the reliability of the following elements: each sensor, the transmission from sensors to the BAN gateway, and the transmission from the BAN gateway to the HMS through the home gateway.

Parente et al. (2011) propose reliability values for the type of sensors used in our use case, namely the Heart Rate Monitor (HRM), the Pulse Oxymeter (POxy), the Shygmomanometer (Shygm), and the Accelerometer (Acc), which are used to initialise the attribute *calculatedReliability* of the tasks “read value”.

Based on the measures of Baig et al. (2014), we establish the reliability value associated to the transmission from sensors to the BAN gateway, which is used to initialise the *calculatedReliability* of the “receive value” tasks. For setting the reliability value for the transmission from the BAN gateway to the HMS, through the home gateway, we consider both connections together to simplify the study. This reliability value is used to initialise the *calculatedReliability* of the task “receive alarm” of the HMS.

The base case scenario, as illustrated in Table 2, considers the values proposed for the reliability of sensors (Parente et al., 2011); the value 0.992 for the reliability of transmission from sensors to the BAN gateway; and the value 0.99 for the reliability of transmission from the BAN gateway to the HMS.

The *calculatedReliability* attribute was set to 1.0 for the remaining activities and events, such as the process start, the evaluation of the received values in the BAN gateway, and the “assist patient” activity. In addition, the *requiredReliability* value for all process activities and events was set to 0.6, as this was assumed to be the minimum acceptable reliability.

The reduction rule for the fault-tolerant gateway considers four feasible combinations of receiving two out of three signal devices: (HRM, POxy, Shygm), (HRM, POxy), (HRM, Shygm), and (POxy, Shygm).

Table 2: Reliability values for activities and transmissions for the base case scenario.

BAN devices (sensors)	Raw Reliability		
	Sensor	Sensors to Gateway	BAN Gateway to HMS
HRM	0.8	0.992	0.99
POxy	0.7	0.992	0.99
Shygm	0.6	0.992	0.99
Acc	0.9	0.992	0.99
Overall reliability	0.6901		

For the base case scenario, the reliability of the process takes the value 0.6901.

The study continued by making variations on different reliability values and assessing the resulting reliability of the global process. Figure 2 displays the results of this study. Chart (a) displays the results of the variation of the Accelerometer reliability in three scenarios. The base case scenario corresponds to fix all the other values of the original base case (Table 2) and making the reliability of the accelerometer vary in the interval [0.6; 1], using steps of 0.01. The worst case scenario differs by setting the reliability values of the remaining sensors to 0.6 (the minimum allowed value), while for the best case the reliability of the other sensors was set to 0.99 (considering an optimistic value). Chart (b) shows the effects on the process reliability due to variation of the HRM reliability considering the same scenarios. As receiving (or not) information from the other sensors in the fault tolerant pattern has the same impact, this chart would be the same for the sensors POxy and Shygm. Chart (c) displays the impact of varying the reliability of transmission from the sensors to the BAN gateway, for similar scenarios – worst case (all the sensors’ reliability set to the minimum 0.6), base case (all values set to the base) and best case (all the sensors’ reliability set to 0.99). Finally, chart (d) discloses the dependence of

process reliability from the reliability of the BAN gateway to the HMS transmission, using the previous scenarios.

The results reveal that the reliability of the process is mostly sensitive to reliability variations of the transmission from the sensors to the BAN gateway (chart (c)), then to variations of the accelerometer reliability (chart (a)), to variations of transmission from the BAN gateway to the HMS (chart (d)), and, finally, to the reliability of a single sensor (HRM, Pulse Oxy, Shygm) (chart (b)). The analysis of scenarios for the different charts allows concluding that the process reliability is more sensitive to variations of the value under analysis in the best case scenario and less sensitive in the worst case scenario. Nevertheless, the process reliability is insensitive to reliability variations of the sensors HRM, POxy, and Shygm for the best case scenario.

The charts also allow identifying variation ranges for reliability values of the different elements that meet the required reliability for the overall process. In addition, few conditions allow to reach an overall reliability greater than 0.9 – if the transmission from the sensors to the BAN gateway has a reliability of at least 0.92.

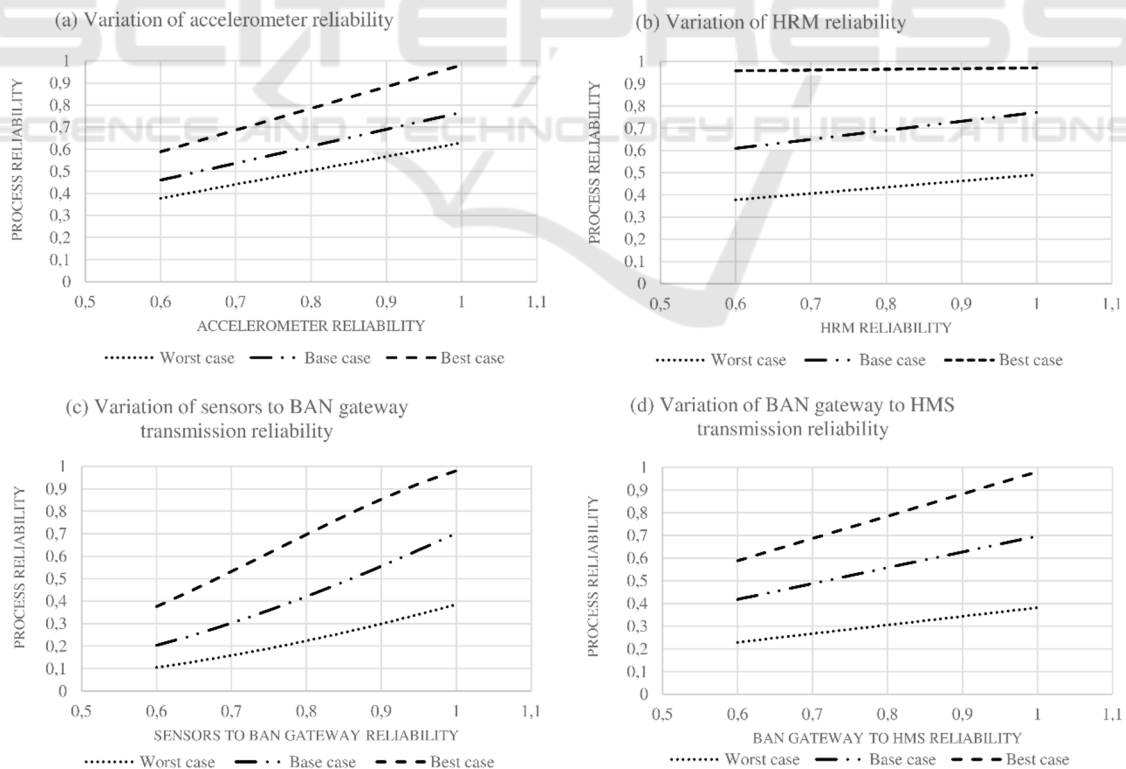

Figure 2: - Impact on the process overall reliability due to varying separate reliabilities: a) variation of accelerometer reliabilities (upper left); b) variation of HRM reliability (upper right); c) variation of sensors to BAN gateway transmission reliability (lower left); variation of BAN gateway to HMS transmission reliability (lower right).

## 6 CONCLUSIONS AND FUTURE WORK

In this paper we presented a new approach to calculate the overall reliability of a certain AAL system and the way its components interact with each other. We use a BPM approach to model these interactions and to derive the combined reliability. For this, we extend the BPMN language to include reliability information for each process element and use the SWR algorithm to calculate the overall process reliability.

The study presented in section 5 exemplifies how to proceed to assess different conditions of an AAL BPMN process that involves AAL system components. This assessment can be made at design time to analyse the feasibility of the process, for instance, if a minimum level of reliability is assured. It allows to identify the elements which have the highest impact on process reliability and, therefore, to design the system architecture and set the requirements for system elements.

Additionally, reliability can be computed at run time to monitor process executions hence providing an approach to identify low reliability services. In that case, for instance the sensor timers could be adjusted as well as the transmission rate increased at run time. We intend to extend a Business Process Management System (such as jBPM - [www.jbpm.org/](http://www.jbpm.org/)), in order to include reliability information in BPMN processes, as well as runtime reliability monitoring features. These features can then help health care professionals to better allocate resources to provide the adequate care to certain AAL-monitored patients, taking into account their overall reliability.

## ACKNOWLEDGEMENTS

This work is partially supported by National Funding from FCT - Fundação para a Ciência e a Tecnologia, under the projects UID/MAT/04561/2013 and UID/CEC/00408/2013.

## REFERENCES

Baig, M. M., GholamHosseini, H., Connolly, M. J., & Kashfi, G. (2014, June). A wireless patient monitoring system for hospitalized older adults: Acceptability, reliability and accuracy evaluation. In *Biomedical and*

- Health Informatics (BHI)*, 2014 IEEE-EMBS International Conference on (pp. 330-333). IEEE.
- Bui, N., & Zorzi, M. (2011, October). Health care applications: a solution based on the internet of things. In *Proceedings of the 4th International Symposium on Applied Sciences in Biomedical and Communication Technologies* (p. 131). ACM.
- Cardoso, A.J.S. (2002) *Quality of service and semantic composition of workflows* (Doctoral dissertation). University of Georgia.
- Cardoso, J., Sheth, A., Miller, J., Arnold, J., & Kochut, K. (2004). Quality of service for workflows and web service processes. *Web Semantics: Science, Services and Agents on the World Wide Web*, 1(3), 281-308.
- Coppolino L., Romano L., Mazzocca N., & Salvi S. (2007). Web Services workflow reliability estimation through reliability patterns. In: *International Conference on Security and Privacy in Communications Networks and the Workshops*. pp. 107-115, IEEE.
- Dar, K., Taherkordi, A., Baraki, H., Eliassen, F., & Geihs, K. (2014). A resource oriented integration architecture for the Internet of Things: A business process perspective. *Pervasive and Mobile Computing*. Elsevier.
- Distefano, S., Ghezzi, C., Guinea, S., & Mirandola, R. (2014). Dependability assessment of web service orchestrations. *Reliability, IEEE Transactions on*, 63(3), 689-705.
- IEEE (2011). *IEEE Standard for Local and metropolitan area networks--Part 15.4: Low-Rate Wireless Personal Area Networks (LR-WPANs)*.
- IEEE (2012). *IEEE Standard for Local and metropolitan area networks - Part 15.6: Wireless Body Area Networks*.
- Islam, S.M.R., Kwak, D., Kabir, M.H., Hossain, M., Kwak, K. (2015). The Internet of Things for Health Care: A Comprehensive Survey. In *Access, IEEE*, vol.3, no., pp.678-708.
- Jara, A. J., Zamora, M. A., & Skarmeta, A. F. (2011). An internet of things---based personal device for diabetes therapy management in ambient assisted living (AAL). *Personal and Ubiquitous Computing*, 15(4), 431-440.
- Krishnakumar, N., & Sheth, A. (1995). Managing heterogeneous multi-system tasks to support enterprise-wide operations. *Distributed and Parallel Databases*, 3(2), 155-186.
- Koren I. & Krishna C.M. (2007) *Fault tolerant systems*. Morgan Kaufmann.
- McNaull, J., Augusto, J. C., Mulvenna, M., & McCullagh, P. (2012). Data and information quality issues in ambient assisted living systems. *Journal of Data and Information Quality (JDIQ)*, 4(1), 4.
- Memon, M., Wagner, S. R., Pedersen, C. F., Beevi, F. H. A., & Hansen, F. O. (2014). Ambient assisted living healthcare frameworks, platforms, standards, and quality attributes. *Sensors*, 14(3), 4312-4341.
- Mukherjee, D., Jalote, P., & Nanda, M. G. (2008). Determining QoS of WS-BPEL compositions.



- In *Service-Oriented Computing–ICSOC 2008* (pp. 378-393). Springer Berlin Heidelberg.
- Object Management Group (2011). *Business Process Model and Notation* (BPMN) Version 2.0.
- Ouyang, C., Dumas, M., Ter Hofstede, A. H., & van der Aalst, W. M. (2007). Pattern-based translation of BPMN process models to BPEL web services. *International Journal of Web Services Research (JWSR)*, 5(1), 42-62.
- Parente, G., Nugent, C. D., Hong, X., Donnelly, M. P., Chen, L., & Vicario, E. (2011). Formal modeling techniques for ambient assisted living. *Ageing International*, 36(2), 192-216.
- Rashidi, P., & Mihailidis, A. (2013). A survey on ambient-assisted living tools for older adults. *Biomedical and Health Informatics, IEEE Journal of*, 17(3), 579-590.
- Respício, A., & Domingos, D. (2015). Reliability of BPMN Business Processes. *Procedia Computer Science*, 64, 643-650.
- Rodrigues, G. N., Alves, V., Silveira, R., & Laranjeira, L. A. (2012). Dependability analysis in the ambient assisted living domain: An exploratory case study. *Journal of Systems and Software*, 85(1), 112-131.
- Siewiorek D. & Swarz R. (2014) *Reliable Computer Systems: Design and Evaluation*. Digital Press.
- van Der Aalst, W. M., Ter Hofstede, A. H., Kiepuszewski, B., & Barros, A. P. (2003). Workflow patterns. *Distributed and parallel databases*, 14(1), 5-51.

