

Design of car frontal protection system using neural networks and genetic algorithm

J. Majak*, **M. Pohlak****, **M. Eerme*****, **T. Velsker******

*Tallinn University of Technology, Ehitajate tee 5, Tallinn, Estonia, E-mail: juri.majak@ttu.ee

**Tallinn University of Technology, Ehitajate tee 5, Tallinn, Estonia, E-mail: meelis.pohlak@ttu.ee

***Tallinn University of Technology, Ehitajate tee 5, Tallinn, Estonia, E-mail: martin.eerme@ttu.ee

****Tallinn University of Technology, Ehitajate tee 5, Tallinn, Estonia, E-mail: tarmo.velsker@ttu.ee

crossref <http://dx.doi.org/10.5755/j01.mech.18.4.2325>

1. Introduction

In general, the car frontal protection systems are designed with an aim to protect vehicles. However, the use of traditional vehicle protection systems may cause certain risk to pedestrian safety. There are two principally different types of the car frontal protection systems: original equipment and separate technical units.

The aim of this study is to design separate technical units of a vehicle which basic components include tubular parts and the brackets. The final product designed had to satisfy the requirements of the Directive 2005/66/EC of the European Parliament and of the Council [1]. In the following, the car frontal protection system is considered as a complementary energy absorbing structure.

A large number of papers covering different impact energy absorbing problems can be found in literature [2-6]. Al Galib et al. 2004 [2] have studied experimentally and numerically the energy absorption in axially loaded circular aluminium tubes (compressive loading). Static and dynamic analysis of the circular thin-walled tubes with various mass and impact velocity has been performed. FE analysis results are found to be in good agreement with test results. Alghamdi 2001 [3] has studied different deformation modes (axial crushing, lateral indentation) of energy absorbing structures such as circular and square tubes, honeycombs, sandwich plates, etc. Gupta 2001 [4] has studied the applicability of structural foam in car protection system design. The potential areas where the steel structures can be replaced with structural foam were found out. An aim of such replacement is to provide light weight design and advanced energy absorption properties. The frontal crash of vehicles is studied by Griškevičius et al. 2003 [5]. Dependence of energy absorption capabilities on age of the vehicle has been detected. It is pointed out that modern AVC longeron columns may absorb several times more energy than corroded longeron columns in old vehicles. De Kanter 2006 [6] has performed experimental and numerical analysis of energy absorbing structures designed using multi-materials. The crushing behaviour of the metallic and plastic cylinders has been analysed. It has been observed that both metallic and composite characteristics are common to the multi-material elements in the crashing behaviour. The techniques for integrating metal and polymer materials were discussed.

Due to new regulations (more strict requirements constituted by the Directive 2005/66/EC) the frontal protection systems of a vehicle should be redesigned in order to improve their energy absorption (softer) in the case of

car-pedestrian accidents [7-10]. Du Bois et al. 2004 [7] provide an overview of the vehicle design safety problems. In [8] the brake assist system is analysed and its advantages are pointed out. In Matsui [9] the lower extremity injury is investigated. The influence of some key factors - vehicle bumper height and impact velocity is discussed. It appears that in the case of impact velocity in range 20-30 km/h the basic injury is knee ligament, but in the case of impact velocity near 40 km/h the injury is a fracture of the lower extremities. The cushioning methods and new trends in bumper design (lower stiffeners, beam face features, etc) are reviewed by Schuster 2006 [10]. In [10] special attention is paid to techniques allowing reducing the lower limb impacts of pedestrian.

The design of frontal protection system of a vehicle is commonly based on application of optimisation techniques [11, 12]. In [11] the crashworthiness analysis is performed by use of software package LS-OPT. In order to save resources the meta-modelling techniques are employed.

Optimal design of a crash box is investigated by Wang [12] considering the difference between maximum and minimum force values as objective function. Such an approach allows obtaining more smooth distribution of the force values. Main attention is paid to shape optimization of a crash box.

This paper studies the possibilities of increasing the safety of pedestrians in the case of traffic accidents. The frontal protection system, consisting of tubular parts and the brackets, is clamped to a vehicle. Latter amplification is performed without structural changes of the vehicle. Thus, the energy absorbing structures of the vehicle holds good. The study is focused to the design of the brackets. The key factors need to be considered in design of the brackets are the safety of the pedestrians and mechanical properties of the car accessories. There are two opposite kind of constraints on design of the brackets. Firstly, the car protection system must be flexible enough in order to evade extreme accelerations of human body in case of the traffic accident. Secondly, the car protection system must be stiff enough in order to withstand to the accelerations of the car. This allows using extra lights fastened to car protection system.

The size, shape and topology of the fastening components are subjected to optimization in order to achieve maximum energy absorption. The optimal design problem posed involves several complexities, like large plastic deformations, geometric and physical nonlinearities (studied by the authors in [13, 14]), impact loading, contact

modelling and quite strict limitations on the design space accrue from the geometry of the brackets (small dimensions), the requirements set by the manufacturer and the EU directive [1].

In this study the FE software package LS-DYNA is used for the car-pedestrian crash situation analysis. The approximation of the objective and constraint functions is modelled by use of a neural network and search for an optimal design is accomplished by applying genetic algorithm. The real-coded genetic algorithm is employed, which allows to provide higher accuracy. However, in a standard formulation the genetic algorithm may converge close to an optimal solution. The refined algorithms are proposed for design improvement. The function approximation and optimization modules are realized in MATLAB and C++ programming environment.

Due to high safety requirements (safety of pedestrian) two alternate solutions are developed and compared (first approach is introduced in [15], where the solution is treated by the use of optimization software package LS-OPT). A theoretical estimate on the deformation energy is given.

2. Estimate on deformation energy

In the following it is assumed that the velocity v_0 of the legform coincide with that of the car protection system. In the case of simplified model the kinetic energy can be given as

$$E_B = m \frac{v_0^2}{2}, \quad E_D = (M + m) \frac{v_0^2}{2} \quad (1)$$

where the indexes E_B and E_D correspond to the kinetic energy before and during crash and v_0 is initial velocity of the legform. The masses of the legform and the car protection system are denoted by m and M , respectively. The formula of the deformation energy of the bracket D_D can be expressed as

$$D_D = E_B - E_D \quad (2)$$

Computing the deformation energy as an integral of the

$$E_D = \int F ds \quad \text{or} \quad E_D = \int F dt \quad (3)$$

Latter formulas describe dependence of the reaction force F on the velocity v .

3. Testing procedures

The Directive 2005/66/EC defines several different tests for the frontal protection system (Directive 2005). The tubular accessories fastened to the front of the car may worsen considerably the situation for a pedestrian in case of an accident, so only minimum requirements can be met without adding sophisticated systems (like airbags, etc). A minimum test is the lower legform impact test. The car frontal protection systems with a height of over 500 mm need for the upper legform impact test.

In the current study, the height of the car frontal protection system is limited up to 500 mm and the safety

requirements corresponding to upper legform test can be omitted (Fig. 1).

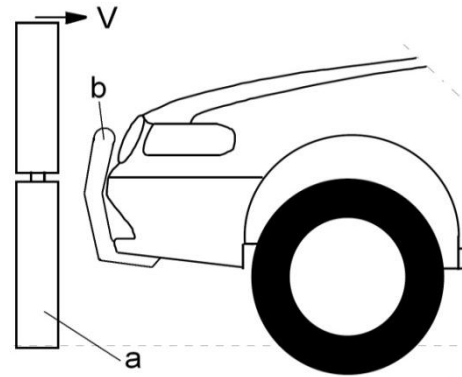

Fig. 1 Lower legform impact test

The legform 'a' was shot at the speed v at the car frontal protection system 'b' ($v = 11.1$ m/s). The following sensors were installed in legform impact or: an acceleration sensor; a bending angle sensor; shear displacement sensor. The directive 2005/66/EC [1] requires that

$$\alpha \leq 21^\circ, \gamma \leq 6 \text{ mm}, a_{ur} \leq 200g, \left(g = 9.81 \frac{\text{m}}{\text{s}^2} \right) \quad (4)$$

where α , γ and a_{ur} stand for the maximum dynamic knee bending angle, maximum dynamic knee shearing displacement and the acceleration measured at the upper end of the tibia, respectively. The constraints (4) hold good for the vehicles with total permissible mass less than 2500 kg. For more weighty vehicles the values of the parameters α , γ and a_{ur} are 26.0° , 7.5 mm and 250 g, respectively. The most complicated task is handling of the constraint subjected to acceleration.

An overview on energy absorbing structures including laminates, honeycombs and rings is given in [3, 6, 16]. Various materials (solid metals, composites, multi-materials) are utilized in these structures. The energy absorption structures can be categorized into two main types characterized by (Fig. 2):

- high peak of reaction force (type I);
- flat load-displacement curve (type II).

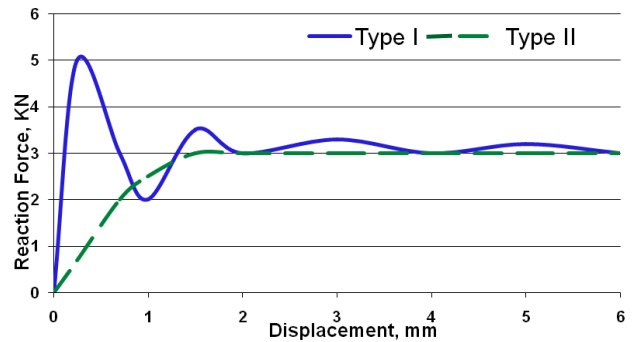

Fig. 2 Force-displacement relationship: 2 types of energy absorbing structures

Obviously, it is desirable that the reaction force will increase steadily to certain given level and then remain unchanged [16]. In this study the energy absorbing structure of type I (bracket) was redesigned by changing the

geometry, adding cutouts, folds and performing parameter design. The resulting bracket belongs to the energy absorbing structure of type II.

The acceleration can be decreased by employing optimal design techniques for determining optimal configuration of the frontal protection system. Let us return to the lower legform impact test described in Fig. 1. Corresponding acceleration distribution is depicted in Fig. 3. Obviously, the constraints imposed on the acceleration are not satisfied in the case of tubular parts and the bracket used by the producer originally (Fig. 3). Thus, it can be concluded that the car frontal protection system in its original configuration is too stiff.

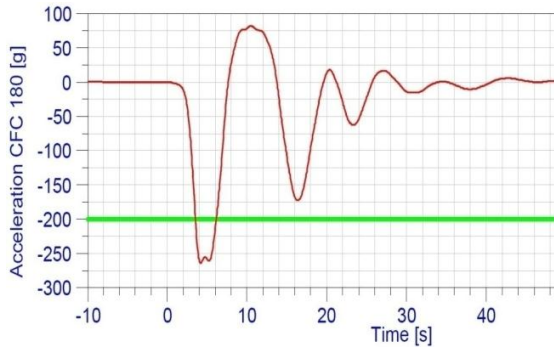

Fig. 3 Acceleration diagram: lower legform impact test

In the current study the main attention is paid to design of the fastening components as energy absorbers. In Fig. 4 is shown initial design of the bracket suggested by the manufacturer. The main aim is to determine the optimal values of the design variables a , b , c , d and e shown in Fig. 4. Initial topology of the bracket is given by manufacturer, but certain changes in topology are allowed (the fold: form, location; etc.).

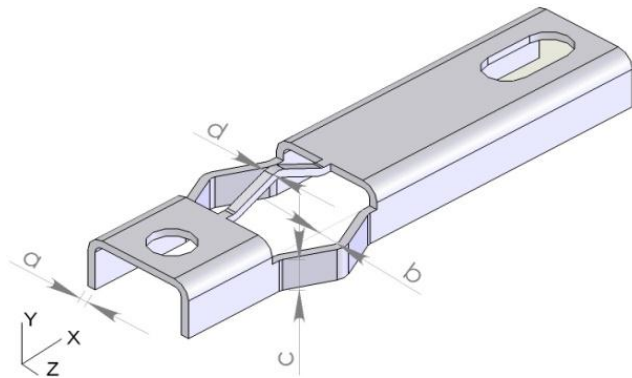

Fig. 4 Energy absorbing structure

The properties of the tubular components were determined by applying robust design and technological constraints.

4. Objective and constraint functions

Obviously, one of the most realistic and practical objective for posed problem is minimization of the peak force (acceleration). However, not only the first peak force, but also a sudden change in the force (following unloading) constitutes a potential risk for the pedestrian. For that reason the above posed problem is considered as multicriteria optimization problem and formulated as

$$\min(F_1(\bar{x}), F_2(\bar{x})) \quad (5)$$

Subjected to linear and nonlinear constraints given as

$$x_i \leq x_i^*, \quad -x_i \leq -x_i^{**}, \quad u_c = \sqrt{u_2^2 + u_3^2} \leq u^*, \quad (i=1, \dots, n) \quad (6)$$

In Eq. (5) $\bar{x} = (x_1, x_2, \dots, x_n)$ is a vector of independent design variables. The objectives $F_1(\bar{x})$ and $F_2(\bar{x})$ stand for peak force and difference between the maximal and the minimal force, respectively

$$\left. \begin{aligned} F_1(\bar{x}) &= \max_t F(t, \bar{x}) \\ F_2(\bar{x}) &= \max_t F(t, \bar{x}) - \min_t F(t, \bar{x}) \end{aligned} \right\} \quad (7)$$

In Eq. (7) $F(t, \bar{x})$ stands for axial (frontal) force component and t is a time. Nonlinear constraint (6) is set on the displacements in the $y-z$ plane. The protection system of a vehicle designed should satisfy two requirements simultaneously:

- must be a good energy absorber;
- must have high stiffness characteristics in the directions perpendicular to the moving direction.

The weight of the car frontal protection system is assumed as an acting load. The stiffness of the car frontal protection system as a whole is determined experimentally by measuring the displacements in the y and z direction denoted by u_2 and u_3 in Eq. (6), respectively. The constraint on stiffness is described by Eq. (6), where u^* is a given limit value. Thus, in normal car exploitation conditions the Eq. (6) must be satisfied.

5. Solution algorithm

The weighted summation is the simplest and most commonly used technique employed for solving multi-objective optimization problems. The Pareto optimality concept can be considered as a most general approach for solving multicriteria optimization problems. However, an analysis done for the current problem allows to conclude that the objectives considered are not in contradiction. Thus, there is no reason to apply the Pareto optimality based approach. The two optimization techniques considered in the following are: the weighted summation, compromise programming.

The approaches used for the Genetic algorithms (GA) improvement: two stage GA and the hybrid GA. These techniques are discussed in more detail above (design improvement). Basic steps of the design procedure proposed are given in Fig. 5. The experimental validation of the computer simulation is included in the algorithm in order to describe the full design process. Actually, the impact tests are performed in TÜV Rheinland (Germany). The static compression tests of the fastening components are executed in TUT (Tallinn University of Technology). The topology of the bracket has been modified based on experimental data.

The major modules of the algorithm are described in detail in the following sections.

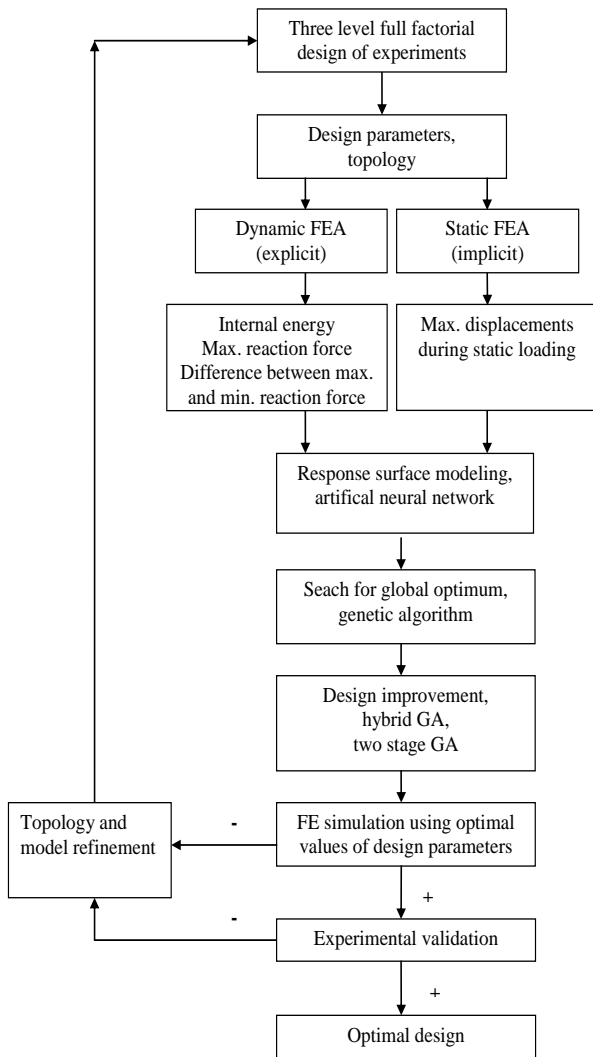

Fig. 5 Basic steps of the design procedure

6. Numerical analysis

In the following the finite element analysis software package LS-DYNA is employed and fully integrated shell elements are considered [17]. The multi-linear relationship is assumed for describing the stress-strain behavior. The plastic anisotropy is modeled by use Hill's yield criterion. Two kind of FEA is realized:

- dynamic analysis - crash simulation;
- static analysis - stiffness evaluation.

It can be seen from Fig. 5 that the values of the input data for FEM analysis (i.e. the design variables shown in Fig. 4) are determined by design of experiment and the values of the output data obtained (i.e. maximal reaction force, difference between maximal and minimal reaction force, maximal displacements during static loading) are utilized for response modeling.

The FEA model proposed is validated against results obtained from experimental study. The brackets with different configurations were tested. Changes in topology of the bracket may change also the number of design variables (from 4 up to 8). The compression tests performed allows obtaining initial values of the force components and deformation modes. The results of the FEA and experimental tests are shown in Fig. 6, where $a = 1.6$ mm, $b = 12$ mm, $c = 6$ mm and $d = 10$ mm. Note that here is

assumed that the shape of the fold is triangular and the design parameter e is omitted (bend angle is used instead of design parameter e).

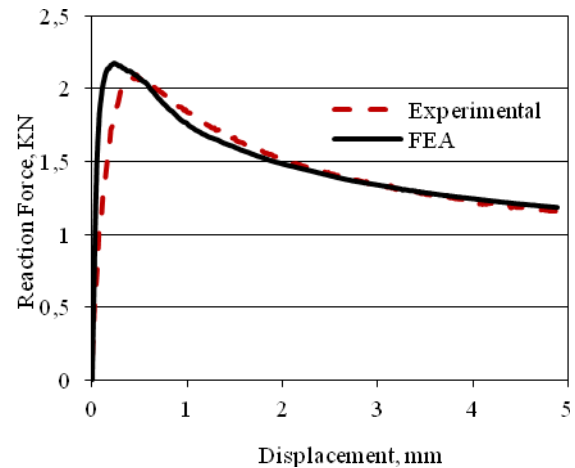

Fig. 6 Load-displacement relation

The FEA results appear to be close to corresponding experimental results (see Fig. 6). Remarkable differences in values of the reaction force are observed in the case of brackets with inner folds, where the folded parts of the bracket move into contact. Actually here take place sliding between the contacting surfaces. Occurrence of the sliding can be confirmed experimentally, since the symmetry conditions are not fulfilled ideally in an experimental test, but not numerically. Even in this exceptional case, good agreement between numerical and experimental results can be found in the range of small deformations corresponding to peak force. Remarkable differences in the values of reaction force can be observed in the case of large deformations (caused by contact between the folded surfaces). Obviously, the first peak of reaction force is the most significant in regard to pedestrian safety.

The dependence of the reaction force on design parameters a , b , c , e is illustrated in Fig. 7.

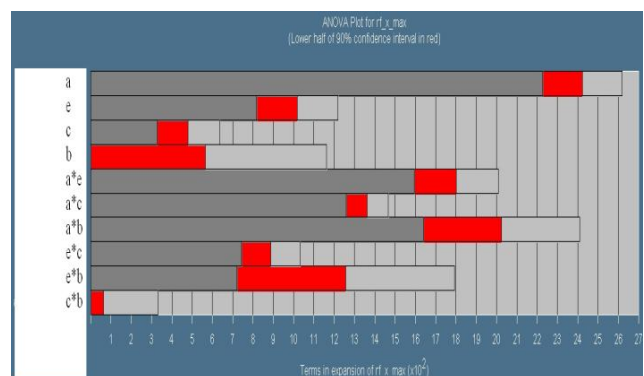

Fig. 7 The influence of design parameters a , b , c , e and their interactions on the value of the reaction force

The sensitivity of the reaction force is highest with respect to thickness and lowest with respect to the upper fold. Note that the results given in Fig. 7 depend on the selection of the design space. The values of the reaction force may change more than 10 times due to changes in design parameters and the topology of the bracket. Also, the nonlinear constraint Eq. (6) deploys substantial restrictions on original design space.

7. Surrogate models

The evaluation of the objective and constraint functions described above includes time consuming FE simulations.

In the following the FE analysis results are used as response values, corresponding to the data set of design variables. The artificial neural networks (ANN) are used for the response modeling. The ANN based approximation of the objective and constraint functions is realized by the authors in software package MATLAB and C++ programming environment. Levenberg-Marquardt algorithm was used to train the ANN model. It is a compromise between the gradient descent and Gauss-Newton optimization methods used widely in engineering applications [20]. In the first and second layer of the ANN the radial bases and linear transfer functions are employed, respectively. In [15] the posed optimization problem is realized by use of software packages LS-OPT (combined with LS-DYNA). The solution is analogous to the current approach.

8. Optimization

In this section, the optimization modules are discussed in detail.

8.1. Why GA?

GA were first developed by Holland [18]. Traditional gradient based optimization methods have a trend to converge to the nearest optimum (which may appear to be local), also here is need for computation of the derivatives of the objective and constraint functions with respect to the design variables. In the following, a genetic algorithm is employed for solving the optimization problem posed. The GA has the following advantages over traditional gradient based techniques:

- in general, the convergence to global extreme can be expected;
- integer type design parameters can be used;
- computation of derivatives of objective and constraints functions is not required.

However, there are also some disadvantages common to GA:

- convergence to the solution close to global optimum (not exactly optimum);
- relatively long computing time.

In order to overcome the above mentioned drawbacks, several refined GA approaches are proposed in literature [19]. Henz et al. [19] studied optimization of injection gate locations in liquid composite molding process and presented a global–local search approach. The hybrid search approach used include a global search performed by use of GA and was improved with a gradient search (continuous sensitivity equations). In [20–22] multilevel optimization strategy has been developed and validated by solving different engineering design problems (design of large composite structures, design of sandwich panels, etc). In [23] a novel GA, particularly suited to hardware implementation, is introduced. The optimal individual monogenetic algorithm (OIMGA) is treated, which includes global and local searches with hierarchical structure.

8.2. Search for an optimal solution

As mentioned above the objectives considered are not in contradiction and the Pareto optimality concept is not employed. First the two objectives given by Eq. (7) are normalized

$$\left. \begin{aligned} f_1(x) &= \frac{F_1(x) - \min F_1(x)}{\max F_1(x) - \min F_1(x)} \\ f_2(x) &= \frac{F_2(x) - \min F_2(x)}{\max F_2(x) - \min F_2(x)} \end{aligned} \right\} \quad (8)$$

Next the following multicriteria optimization techniques are employed:

- weighted summation (Eq. (9));
- compromise programming (Eq. (10)).

$$f_{ws} = \sum_{i=1}^m w_i f_i \quad (9)$$

$$f_{cp} = \left[\sum_{i=1}^m (w_i f_i)^p \right]^{1/p} \quad (10)$$

In Eqs. (9) and (10) m stand for the number of objectives ($m = 2$) and w_i for weights of the objectives. The combined objective function has been minimized by use of genetic algorithm.

In optimization algorithm the values of the reaction force in moving direction and the $y - z$ displacement are determined from corresponding response surfaces introduced above. The response surfaces built by use of ANN are given by analytical formulas. Thus, the evaluation of the objective function in optimization algorithm is computationally relatively cheap operation. In this study the MATLAB Genetic algorithm and Direct Search Toolbox is employed for minimization of the objectives (9) and (10). In order to achieve higher accuracy the real-coded approach of the genetic algorithm is considered. It was not surprising that combined use of ANN and standard GA lead to the solution close to global extreme, but does not provide convergence to global extreme (remains to bend near global extreme). Thus, certain improvement of the algorithm seems reasonable.

In [15] the leap-frog algorithm is applied and the solution of the optimization problem is realized by the use of software package LS-OPT. In the following different approach is used.

8.3. Design improvement (refined algorithm)

As mentioned above, two different approaches are considered for design improvement – the two stage GA and the hybrid GA. Both algorithms consist from a global search and one or more local searches. In the case of the two stage GA, the genetic algorithm is employed for search in both levels (global and local). The domain for the local search is given as

$$x_i^g - \delta_i \leq x_i \leq x_i^g + \delta_i, \quad (i = 1, \dots, n) \quad (11)$$

where x_i^g is a value of the design variable corresponding to global search and δ_i describes the deviation. The lower and upper bound vectors of the design variables are redefined as

$$lb[i] = x_i^g - \delta_i, \quad ub[i] = x_i^g + \delta_i, \quad (i = 1, \dots, n) \quad (12)$$

Obviously, the numerical results obtained using sub sequential runs of the GA code may differ, since the GA is based on a stochastic search method. Furthermore, if several equal or close minimal values of the fitness function exist in the global design space, then the optimal solutions corresponding to different subsequent runs of the code may differ significantly (i.e. the values of design variables differ significantly, but the corresponding values of the fitness function are close). In the latter case the design space (11) should be specified and the local search performed for a set of solutions is obtained by applying the global search. The solutions are given in matrix population and the corresponding values of the fitness function in array scores.

The hybrid GA considered herein, include GA and the steepest decent methods applied in global and local level of the optimization algorithm, respectively. The best individual of the population generated by the GA is used as an initial value of the gradient method. In the cases where elite population (set of solutions obtained by fitness-based selection rule) contains individuals, which chromosomes (parameters) differ substantially, it is reasonable to perform local search for all these individuals. Thus, the number of local searches necessary depends on the result of the global search. The local search may be interpreted as a design improvement. To reach the final solution the results of all local searches are to be compared (selection is based on the value of the fitness function). Note that the 2D array population should be sorted using the values of the fitness function given in array scores before the selection of the elite population (initially not sorted).

It was observed that the hybrid GA converges faster and exactly to the extreme value of the objective function in comparison with two stage GA. However, the two stage GA may appear more effective in particular cases when several extreme values of the objective function are expected in the local search domain.

8.4. Freeware based solution

Obviously, the FEA performed above is a problem specific, but the approximations of the objective (constraint) functions as well as optimization are the tasks of more general character. Thus, the solution algorithm treated to solve the latter problems can be applied to solve wider class of similar optimization problems.

For that reason a freeware based solution covering function approximation and optimization tasks in C++ code is developed. Another consideration for the development of C++ code was the fact that the MATLAB GA toolbox has been developed in parallel with the solution of the posed optimization problem (first versions of MATLAB GA algorithm does not support the constrained optimization).

Due to the similar main algorithms used, the numerical results obtained by the use of freeware and

MATLAB based solutions coincide or are close.

The main advantages of the commercial software MATLAB based solution in comparison with the freeware based solution is the presence of advanced tools for graphics.

9. Numerical and experimental results

Satisfaction of the constraints imposed on acceleration is most complicated task. Furthermore, huge acceleration (or corresponding reaction force) is most critical also in terms of pedestrian safety. Thus, the objective f_1 in Eqs. (9) and (10) has higher priority in comparison with objective f_2 . The solution of the posed optimization problem allows reducing the value of the reaction force more than 4 times in comparison with the reference value. The reference solution was chosen with a reserve since the predicting of the value of the y - z displacement u_c (constraint) corresponding to a certain set of design variables is extremely complicated (detailed description is given in section 5). The reaction force versus time relation is given in Fig. 8. The solid and dashed lines in Fig. 8 correspond to the initial and optimal solutions, respectively. The constraints (6) are satisfied in the case of both solutions. The stiffness of the bracket with initial design in the moving direction of the vehicle is much higher than that of optimized bracket. Thus, the total energy absorption is higher in the case of reference solution.

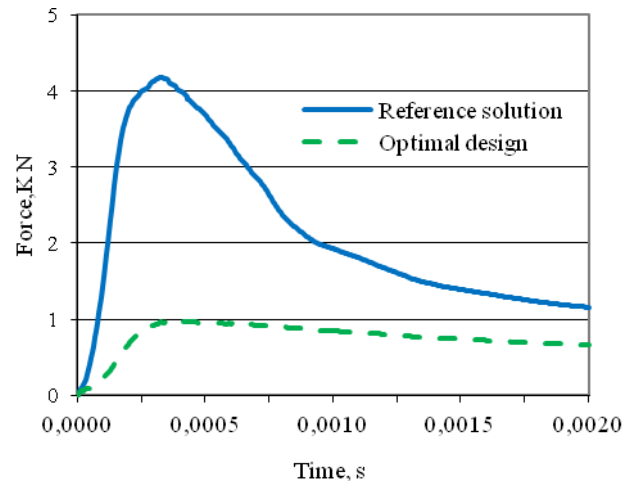

Fig. 8 Force vs. time diagram: reference solution and the optimal design

Obviously, the character of the reaction force curve corresponding to the optimal solution and the character of the curve corresponding to the energy absorber of type II, shown in Fig. 2, are close (Fig. 8). In Table the optimal values of the reaction force components, thicknesses of the metal sheet and also nonlinear constraints corresponding to the optimization algorithms introduced in the current paper and in [15] are compared.

Based on results shown in Table, it can be concluded that the values of the reaction force corresponding to GA, the two stage GA and the hybrid GA algorithms are close to each other. However, certain differences between the latter solutions and the solution, obtained by applying software package LS-OPT [15], can be observed. It should be noted that in the case of first three methods the response surface is considered to be "static" i.e. it is not modified

Table

The values of the frontal force components, thicknesses and nonlinear constraints correspond to the optimization algorithms introduced in the current paper and in [15]

Optimization algorithm	GA	Two stage GA	Hybrid GA	LS-OPT
Frontal force component, N	1157	1134	1125	1067
Thickness of the sheet, mm	1.74	1.72	1.71	1.7
Nonlinear constraint, mm	0.007	0.0073	0.0073	0.0073

during optimization process. In the case of forth solution method (LS-OPT based) the response surface is considered to be dynamic i.e. it is updated in each iteration step. Since the software packages LS-DYNA and LS-OPT are compatible, the sequential executing of explicit and implicit solvers can be realized by introducing a special user defined script. Combining MATLAB with FE solvers is more cumbersome (several restrictions exist on what kind of standalone executable MATLAB code can be compiled with the MATLAB compiler).

The nonlinear constraints have an inequality form in the case of simple GA algorithm and turn to an equality form in the case of all other methods. The optimal design appears most sensitive with respect to the thickness of the bracket (discussed in more detail in section 6). The number of function calls performed by the GA method (global and local level) depends on random values and is not determined uniquely. However, approximately 10-100 times more function calls were observed in the case of the proposed optimization algorithm in comparison with the gradient method.

The two stage GA and the hybrid GA algorithms are discussed above, the solution treated by the use of software package LS-OPT is described in detail in [15]. It is correct to note that the numerical methods used in the software package LS-OPT for optimization differ from those used in the MATLAB and C++ algorithms described above. The LS-OPT version 3.1 features Monte Carlo based point selection schemes. The sub-problem is optimized by the dynamic leap-frog method.

10. Conclusions

1. The design procedure for optimization of the frontal protection system of a vehicle has been proposed. The results obtained in the current study are compared with the results given in [15].

2. The results obtained from experimental study and FE simulations were found to be close to each other (see section 6 for details). The influences of the different design parameters on the final results are estimated. A simple theoretical estimate on deformation energy is given.

3. The energy absorbing component (bracket) designed is characterized by its low cost and simplicity of fabrication.

4. The frontal protection system has been designed according to the Directive 2005/66/EC. As a result, the EU patent application no 07108163 "Mounting bracket for frontal protection system" was submitted. Nine products have passed through the type improvement test.

Acknowledgements

The work has been supported by Estonian Science Foundation grant ETF8485, ETF9441 and targeted financing project SF0140035s12.

References

1. Directive 2005/66/EC of the European Parliament and of the Council (2005) Available from: http://eurlex.europa.eu/LexUriServ/site/en/oj/2005/l_309/l_30920051125en00370054.pdf, Accessed: 2005-11-26.
2. **Al Galib, D.; Limam, A.** 2004. Experimental and numerical investigation of static and dynamic axial crushing of circular aluminum tubes, *Thin-Walled Structures* 42(8): 1103-1137. <http://dx.doi.org/10.1016/j.tws.2004.03.001>.
3. **Alghamdi, AAA.** 2001. Collapsible impact energy absorbers: an overview. *Thin-Walled Structures*, 39: 189-213. [http://dx.doi.org/10.1016/S0263-8231\(00\)00048-3](http://dx.doi.org/10.1016/S0263-8231(00)00048-3).
4. **Gupta, S.** 2001. Using CAE to evaluate structural foam alternatives in B-pillar and bumper designs, In: 3rd European LS-DYNA users conference, Paris, France.
5. **Griškevičius, P.; Žiliukas, A.** 2003. The impact energy absorption of the vehicles front structures, *Transport* 18(2): 97-101.
6. **De Kanter, J.** 2006. Energy absorption of monolithic and fibre reinforced aluminium cylinders, Delft University of Technology, PhD Thesis.
7. **Du Bois, P.; Chou, C.C.; Fileta, B.B.; Khalil, T.B.; King, A.I.; Mahmood, H.F.; Mertz, H.J.; Wisman, J.** 2004. Vehicle Crashworthiness and Occupant Protection, American Iron and Steel Institute, Southfield, 330p.
8. **Lawrence, G.; Hardy, B.; Carroll, J.; Donaldson, W.; Visvikis, C.; Peel, D.** 2004. A study on the feasibility of measures relating to the protection of pedestrians and other vulnerable road users - Final report, In Project report, EC Contract No. FIF.20030937.
9. **Matsui, Y.** 2005. Effects of vehicle bumper height and impact velocity on type of lower extremity injury in vehicle-pedestrian accidents, *Accident Analysis & Prevention* 37(4): 633-640. <http://dx.doi.org/10.1016/j.aap.2005.03.005>.
10. **Schuster, P.J.** 2006. Current Trends in Bumper Design for Pedestrian Impact, SAE Technical Papers No. 2006-01-0464.
11. **Hörmann, M.; Schulz, A.; Rust, W.** 2003. Structural Optimization using LS-OPT: Basics and Examples, Proceedings of 21st CAD-FEM Users' Meeting, Potsdam.
12. **Wang, H.; Müllerschön, H.; Mehrens, T.** 2005. Shape Optimization of a Crashbox using HyperMorph and LS-OPT, In: Proceedings of 4th German LS-DYNA forum, Bamberg.
13. **Majak, J.; Hannus, S.** 2005. Optimal design of plastic cylindrical shells of von Mises material, *Structural and Multidisciplinary Optimization* 30(3): 227-232. <http://dx.doi.org/10.1007/s00158-004-0507-8>.
14. **Pohlak, M.; Majak, J.; Karjust, K.; Küttner, R.** 2010. Multicriteria optimization of large composite parts, *Composite Structures* 92(9): 2146-2152.

- <http://dx.doi.org/10.1016/j.compstruct.2009.09.039>.
15. **Pohlak, M.; Majak, J.; Eerme, M.** 2007. Optimization study of car frontal protection system, *Int. J. for Simulation and Multidisciplinary Design Optimization* 1(1): 31-37.
<http://dx.doi.org/10.1051/ijsmdo:2007004>.
 16. **Lu, G.; Yu, T.** 2003. *Energy Absorption of Structures and Materials*, Woodhead Publishing Limited, Cambridge, England, 424p.
 17. **Hallquist, J.O.** 2006. *LS-DYNA Theory Manual*. Livermore Software Technology Corporation.
 18. **Holland, J.H.** 1975. *Adaptation in natural and artificial systems*. Ann Arbor: University of Michigan Press.
 19. **Henz, B.J.; Mohan, R.V.; Shires, D.R.** 2007. A hybrid global–local approach for optimization of injection gate locations in liquid composite molding process simulations, *Composites: Part A*, 38: 1932-1946.
<http://dx.doi.org/10.1016/j.compositesa.2007.03.005>.
 20. **Pohlak, M.; Majak, J.; Karjust, K.; Küttner, R.** 2010. Multicriteria optimization of large composite parts, *J. Composite Structures* 92(9): 2146-2152.
<http://dx.doi.org/10.1016/j.compstruct.2009.09.039>.
 21. **Kers, J.; Majak, J.; Goljandin, D.; Gregor, A.; Malmstein, M.; Vilsaar, K.** 2010. Extremes of apparent and tap densities of recovered GFRP filler materials, *Composite Structures* 92(9): 2097-2101.
<http://dx.doi.org/10.1016/j.compstruct.2009.10.003>.
 22. **Majak, J.; Pohlak, M.** 2010. Decomposition method for solving optimal material orientation problems, *Composite Structures* 92(8): 1839-1845.
<http://dx.doi.org/10.1016/j.compstruct.2010.01.015>.
 23. **Zhu, Z.; Mulvaney, D.J.; Chouliaras, V.A.** 2007. Hardware implementation of a novel genetic algorithm, *Neurocomputing* 71(1-3): 95-106.
<http://dx.doi.org/10.1016/j.neucom.2006.11.031>.

J. Majak, M. Pohlak, M. Eerme, T. Velsker

AUTOMOBILIO PRIEKIO APSAUGOS SISTEMOS PROJEKTAVIMAS NAUDOJANT NEURONINĮ TINKLĄ IR GENETINĮ ALGORITMĄ

R e z i u m ė

Sudarytas optimalus automobilio priekio apsaugos sistemos projektas. Šis straipsnis yra skirtas jungiamųjų komponentų projektavimui aprašyti. Automobilio ir pėsčiojo susidūrimo situacija buvo analizuojama naudojant tikslių sprendinių LS-DYNA. Tikslų ir jėgų ryšio funkcijoms modeliuoti panaudotas dirbtinis neuroninis tinklas, o optimalus variantas nustatytas naudojant genetinį algoritmą. Gauti skaitiniai rezultatai patvirtinti eksperimentiškai.

J. Majak, M. Pohlak, M. Eerme, T. Velsker

DESIGN OF CAR FRONTAL PROTECTION SYSTEM USING NEURAL NETWORK AND GENETIC ALGORITHM

S u m m a r y

Optimal design of the frontal protection system of a car is considered. The study is focused on design of the fastening components. A simple theoretical estimate on deformation energy is given. The car-pedestrian collision situation is analyzed by use of the LS-DYNA explicit solver. Corresponding stiffness analysis is performed by use of the LS-DYNA implicit solver. The approximation of the objective and constraint functions is modeled by use of artificial neural network (NN) and search for an optimal design is performed by use of a genetic algorithm (GA). The obtained numerical results are validated against experimental test results.

Keywords: design, car frontal protection system, neural network, genetic algorithm.

Received February 01, 2011

Accepted June 13, 2012